

ACTUATOR	A (INCHES)	B (INCHES)	C (INCHES)	D (INCHES)	E (INCHES)	WEIGHT* (LBS)
EHPX15U-2-1-046SXX0-115/230-115/24	38.66	15.67	14.09	22.17	1.50	177
EHPX15U-2-1-046SXX0-460-24	38.66	15.67	14.09	22.17	1.50	157
EHPX15U-2-1-072SXX0-115/230-115/24	38.66	16.17	14.09	22.17	1.50	187
EHPX15U-2-1-072SXX0-460-24	38.66	16.17	14.09	22.17	1.50	167
EHPX15U-2-1-100SXX0-115/230-115/24	38.66	16.83	14.13	22.17	1.50	207
EHPX15U-2-1-100SXX0-460-24	38.66	16.83	14.13	22.17	1.50	187
EHPX25U-3-1-210SXX0-115/230-115/24	48.57	20.71	20.19	28.90	2.50	382
EHPX25U-3-1-210SXX0-460-24	48.57	20.71	20.19	28.90	2.50	362
EHPX25U-3-1-420SXX0-115/230-115/24	48.57	20.96	20.19	28.90	2.50	392
EHPX25U-3-1-420SXX0-460-24	48.57	20.96	20.19	28.90	2.50	372
EHPX30U-4-1-370SXX0-115/230-115/24	59.73	23.30	23.31	34.13	3.00	572
EHPX30U-4-1-370SXX0-460-24	59.73	23.30	23.31	34.13	3.00	552
EHPX30U-4-1-740SXX0-115/230-115/24	59.73	23.30	23.20	34.13	3.00	732
EHPX30U-4-1-740SXX0-460-24	59.73	23.30	23.20	34.13	3.00	712
EHPX30U-6-1-1150SXX0-115/230-115/24	65.48	25.04	23.18	37.06	3.00	1247
EHPX30U-6-1-1150SXX0-460-24	65.48	25.04	23.18	37.06	3.00	1227

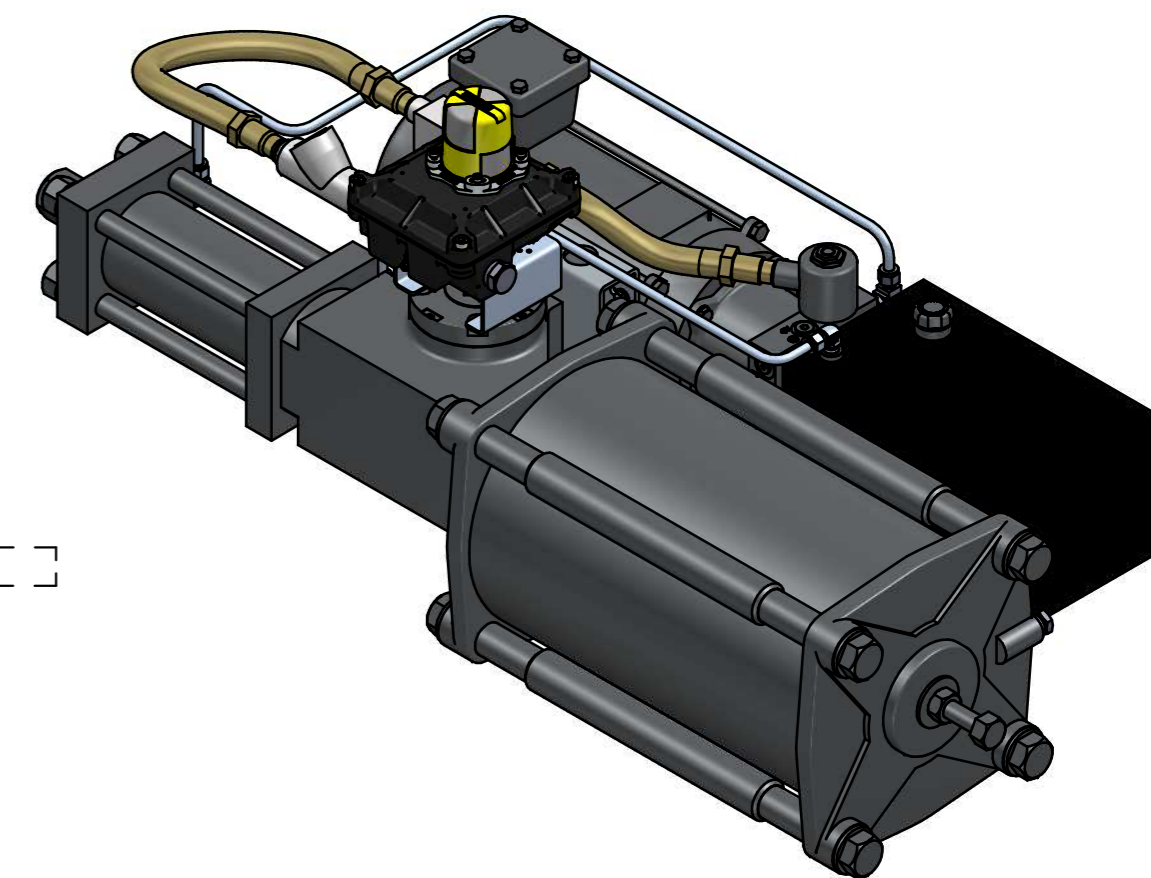
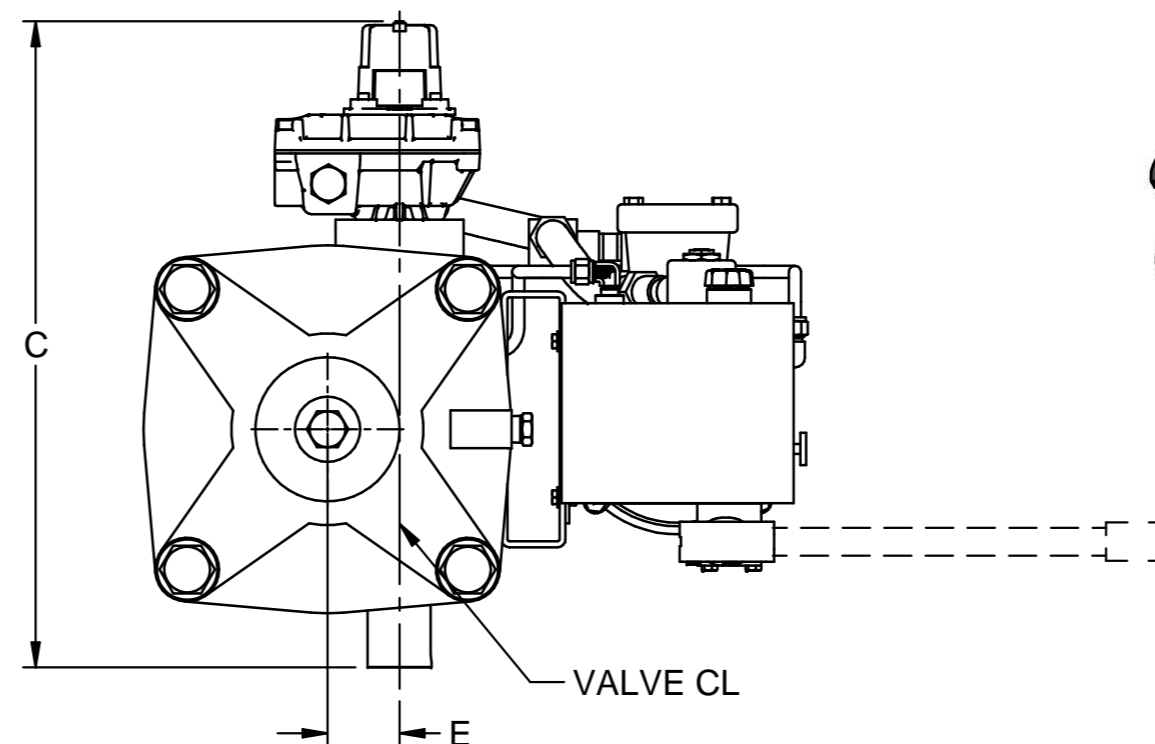
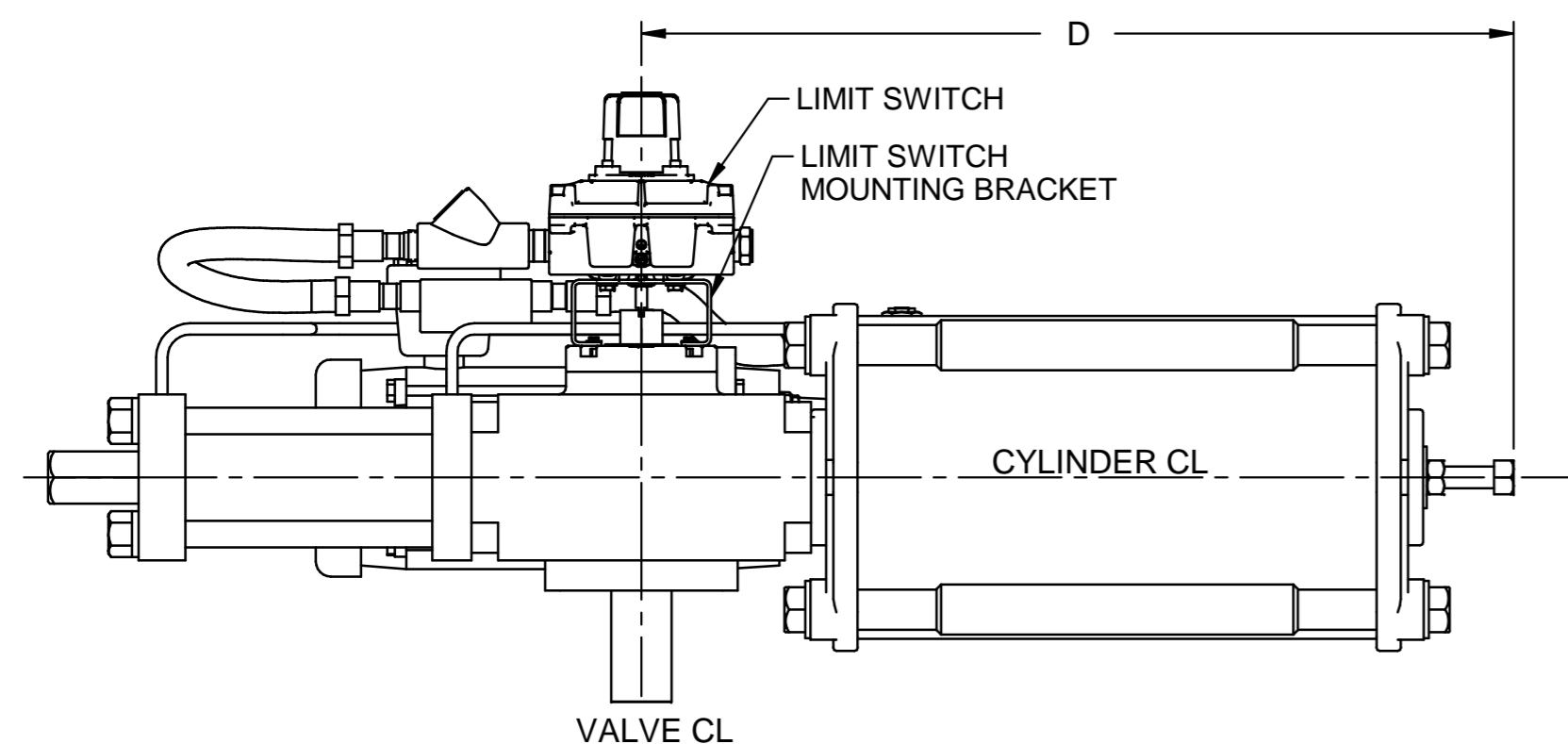

- NOTES:
- PIPE RUNS AND ELECTRICAL WIRINGS MAY VARY FROM THOSE SHOWN AS APPLICABLE.
 - ACTUATOR SHOWN ROTATED TO THE FULL CLOCKWISE POSITION.
 - ACTUATOR AND CONTROL ACCESSORIES ARE SHOWN TO BE MOUNTED ON A VERTICAL STEM.
 - ALL UNUSED ELECTRICAL AND PNEUMATIC ENTRIES SHIPPED WITH THREADED PLASTIC PLUG.
 - * THE WEIGHT MENTIONED IN THE DRAWING IS APPROXIMATE. IF WEIGHT NEEDS TO BE UTILIZED FOR THE PURPOSE OF PERFORMING FURTHER CALCULATIONS OR ANALYSIS, CONSULT FACTORY.
 - ALL THE DIMENSIONS SHOWN ARE APPROXIMATE.

REV	ECN	DESCRIPTION	DATE
00	INITIAL	-	12-Nov-2020
REVISION HISTORY			

THIS DOCUMENT AND THE DATA DISCLOSED HEREIN OR HEREWITH IS NOT TO BE REPRODUCED, USED OR DISCLOSED IN WHOLE OR IN PART TO ANYONE WITHOUT THE PERMISSION OF EMERSON

GENERAL ARRANGEMENT

TITLE: CHARTED DRAWING, OUTLINE DIMENSIONS AND WEIGHTS FOR EHPX ACTUATOR CONFIGURATIONS

CUSTOMER NAME:

PROJECT TITLE:

EMERSON

ORIGINATOR: VPN

CHECKED: DJG

APPROVED:

SCALE: 1:8

SHEET: 1 SIZE: A2

DRAWING No: VA-ED-008-7967

REV: 00