

Biffi EFS 3000 Series

Electric Actuators

The EFS 3000 series are electric quarter-turn spring-return actuators for closing and opening a valve in emergency conditions.

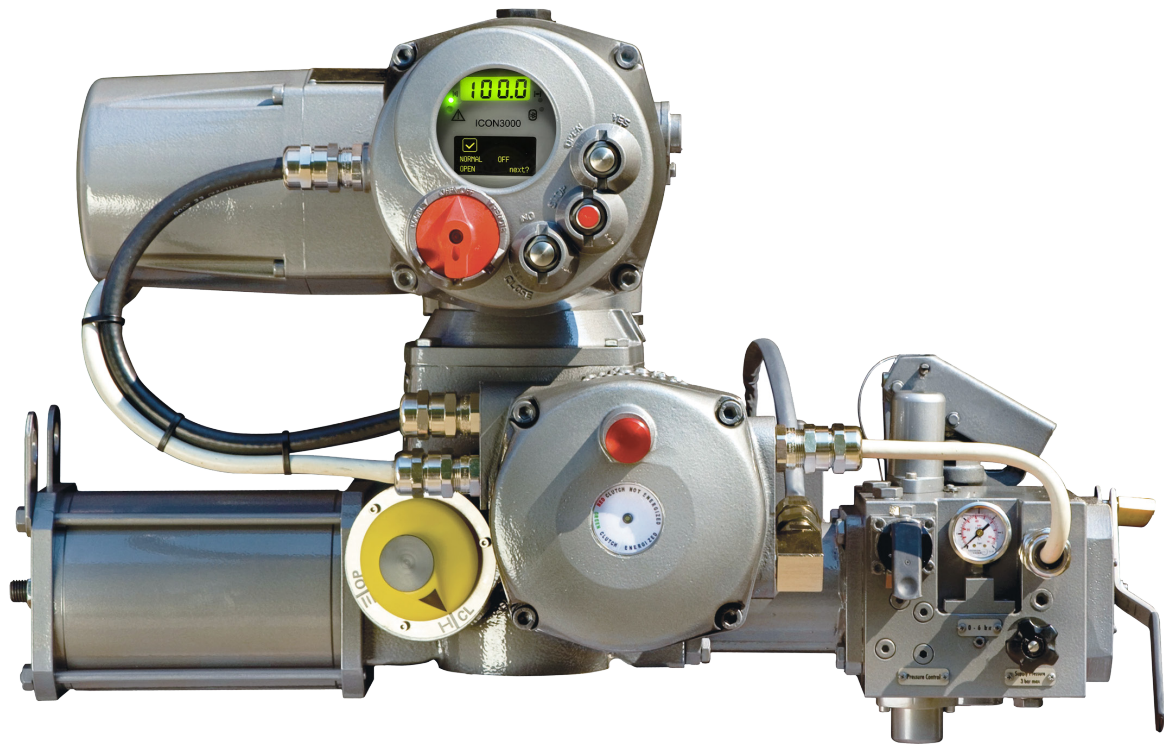

This page is intentionally left blank.

Table of Contents

Section 1: General Application

General Application 5

Section 2: Technical Data

Technical Data 5

Section 3: Approvals

Approvals 5

Section 4: Features

Features 5

Section 5: Main Component Parts

Main Component Parts 6

Section 6: Component Parts

Component Parts 7

Section 7: EFS 3000 Standard Specifications

Non-Hazardous and Hazardous Area Certifications 9

Section 8: Base Version Features

Remote Controls 10

Remote Output Contacts 10

Monitor Relay 10

Intelligent Protection 10

Valve Monitoring 11

Section 9: Performance and Motor Data

Performance Single-Phase Supply 115 V / 50 Hz -
Spring to Close (CL) or Spring to Open (OP)13

Performance Single-Phase Supply 120 V / 60 Hz -
Spring to Close (CL) or Spring to Open (OP)14

Performance Single-Phase Supply 220 V / 50 Hz -
Spring to Close (CL) or Spring to Open (OP)15

Performance Single-Phase Supply 230 V / 50 Hz -
Spring to Close (CL) or Spring to Open (OP)16

Performance Single-Phase Supply 240 V / 50 Hz -
Spring to Close (CL) or Spring to Open (OP)17

Performance Three-Phase Supply 400 V / 50 Hz -
Spring to Close (CL) or Spring to Open (OP)18

Performance Three-Phase Supply 400 V / 50 Hz -
Spring to Close (CL) or Spring to Open (OP)20

Performance DC Supply 24 V - Spring to Close (CL) or Spring to Open (OP).....22

Section 10: Overall Actuator Dimensions

Spring to Close23

Spring to Open.....24

Output Drive Dimensions Spring to Close25

Section 11: Wiring Diagram Code

Wiring Diagram Code26

General Application

The EFS 3000 is available in eight (8) sizes and is designed for on/off or inching operation of valves on safety critical applications in the oil and gas, process and general industry sectors, where conventional pneumatic or hydraulic power supply to fail-safe actuators is unavailable.

Technical Data

Power supply: 3-phase from 208 to 690 V at 50 or 60 Hz
1-phase from 110 to 240 V at 50 or 60 Hz
Direct Current (DC) from 24 V

Torque output: Spring starting torque up to 18,000 N·m
Spring ending torque up to 9000 N·m
Electric mode starting torque up to 25,500 N·m
Electric mode ending torque up to 12,500 N·m

Ambient temperature

Standard range: -20 to +85 °C

Approvals

Waterproof: IP66 (EN 60529)

Explosion-proof: Ex-d IIB t4 Gb (Gas) and c
Ex tb IIIC T135 °C Db (Dust)

Safety Integrity Level: (IEC 61508-1÷7:2010) - SIL 3

Features

- Spring-return mechanism for moving the valve to the fail-safe position
- Epicyclic gear reduction to increment the output torque of the electric actuator
- Electromagnetic clutch
- Low pressure hydraulic control group for manual operation and operating speed regulation
- Non-intrusive configuration
- User-friendly push-button panel for operation, setting and diagnostics
- Bluetooth® wireless connectivity
- Advanced maintenance data and alarm reports
- Valve condition monitoring
- Configurable 'data logger' function for maintenance and diagnostic programs in recorder or event modes
- User adjustable numeric and graphic displays with 8 language options
- Double sealed terminal block
- Digital contactless torque and position sensing
- Advanced open bus communication protocols:
 - LonWorks®
 - PROFIBUS DPV0, DPV1 and redundant DPV1
 - FOUNDATION™ Fieldbus
 - Modbus®
 - HART®
- Certified for use in SIL 3 applications

Main Component Parts

Figure 1. EFS 3000 Main Component Parts Exploded View

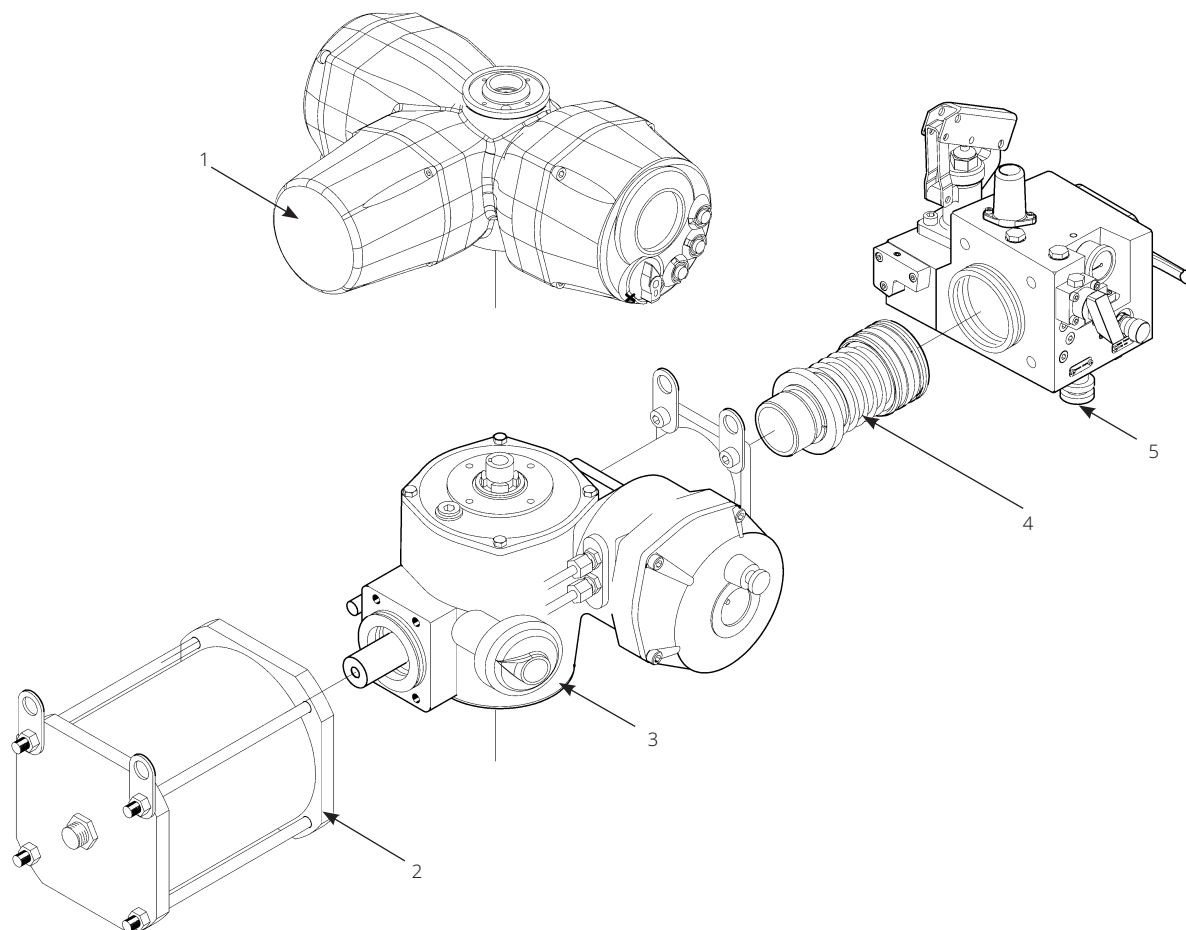

Table 1. EFS 3000 Main Component Parts

Item	Quantity	Description
1	1	ICON3000 electric actuator
2	1	Spring cartridge
3	1	Fail-safe electric actuator
4	1	Spring to close hydraulic actuator
5	1	Hydraulic control group

Component Parts

Figure 2. EFS 3000 Component Parts Exploded View

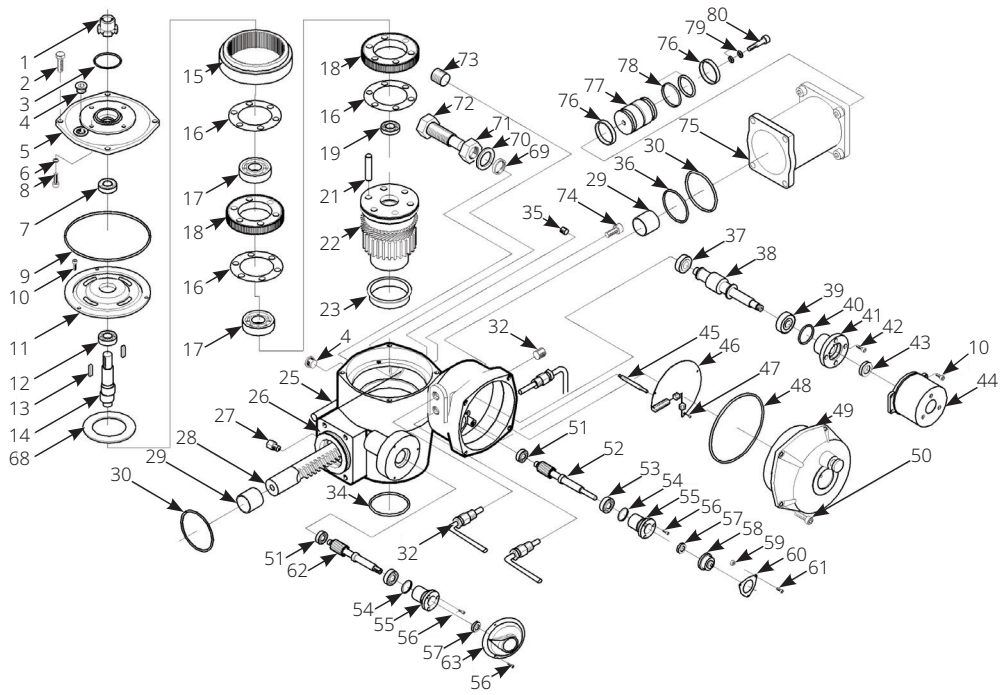

Table 2. EFS 3000 Component Parts (1)

Item	Quantity	Description	Material
1	1	Insert	Carbon steel
2	4	Screw	Stainless steel
3	1	O-ring	Nitrile Butadiene Rubber (NBR)
4	2	Oil plug	-
5	1	Housing cover	Aluminum
6	4	Seal washer	-
7	1	Seal ring	NBR
8	4	Screw	Stainless steel
9	1	O-ring	NBR
10	7	Screw	Stainless steel
11	1	Worm well cover	Aluminum
12	1	Bearing	Carbon steel
13	2	Key	Carbon steel
14	1	Double eccentric shaft	Alloy steel
15	1	Worm wheel	Carbon steel
16	3	Seal ring	Nylon
17	2	Bearing	Carbon steel
18	2	Gear	Alloy steel
19	1	Bearing	Carbon steel
21	6	Pin	Alloy steel
22	1	Splined bush	Alloy steel
23	1	Bush washer	Bronze
25	1	Lever assembly	-
26	1	Housing	Aluminum
27	1	Silencer	-

Table 3. EFS 3000 Component Parts (2)

Item	Quantity	Description	Material
28	1	Rack	Alloy steel
29	2	Bush	Steel-Bronze- Polytetrafluoroethylene (PTFE)
30	2	O-ring	NBR
32	1	Wiring assembly	-
34	1	O-ring	NBR
35	1	Plug	Carbon steel
36	1	O-ring	NBR
37	1	Bearing	Carbon steel
38	1	Worm shaft	Carbon steel
39	1	Bearing	Carbon steel
40	1	O-ring	NBR
41	1	Worm shaft flange	Aluminum
42	4	Screw	Stainless steel
43	1	Seal ring	NBR
44	1	Clutch assembly	-
45	4	Column	Stainless steel
46	1	EFS card	-
47	3	Screw	Stainless steel
48	1	O-ring	NBR
49	1	Cover	Aluminum
50	4	Screw	Stainless steel
51	2	Bearing	Carbon steel
52	1	Position transmitter shaft	-
53	2	Bearing	NBR
54	2	O-ring	NBR
55	2	Position transmitter shaft flange	Aluminum
56	9	Screw	Stainless steel
57	2	Seal ring	NBR
58	1	Potentiometer assembly	-
59	3	Column	Stainless steel
60	1	Position transmitter shaft plate	Aluminum
61	3	Screw	Stainless steel
62	1	Position shaft	Stainless steel
63	1	Position indicator	Plastic
68	1	Pin spacer	Carbon steel
69	1	Seal ring	Carbon steel
70	1	Washer	Carbon steel
71	1	Nut	Carbon steel
72	1	Adjusting screw	Carbon steel
73	1	Screw	Carbon steel
74	4	Screw	Carbon steel
76	1	Guide sliding	PTFE-graphite
77	1	Piston	Carbon steel
78	1	Seal ring	NBR
79	2	O-ring	NBR
80	1	Piston screw	Carbon steel

EFS 3000 Standard Specifications

Non-Hazardous and Hazardous Area Certifications

Table 4. Non-Hazardous/Weatherproof Areas

	Power Supply	Directive Code	Enclosure Code	Extension	Motor Duty	Temperature Range		
						Standard	Low	Extreme Low
All Models	All	IEC EN60529	IP66/68	With or Without	All	-20 to +85 °C / -4 to +185 °F	N/A	N/A

Table 5. Hazardous Area Enclosures
European Hazardous Area Directive – ATEX

	Power Supply	Directive Code	Enclosure Code	Extension	Motor Duty	Temperature Range			
						Standard	Low	Extreme Low	
All Models	All	2014/34/EU	Ex db h IIB T4 Gb Ex h tb IIIC T135 °C Db IP66/IP68	With or Without	Short time max 60 st/h	-20 to +85 °C / -4 to +185 °F	N/A	N/A	
Size 10-20-40-80-160	3-PH				Intermittent up to 200 St/h	-20 to +75 °C / -4 to +167 °F			
Size 10-20-40-80-160	1-PH / 110 V					All			-20 to +60 °C / -4 to +140 °F
Size 10-20-40-80-160	24 V DC								
Size 10-20-40-80-160-320-480	1-PH / 220 V								
All Models	All								

Table 6. European Hazardous Area Directive – IECEX

	Power Supply	Directive Code	Enclosure Code	Extension	Motor Duty	Temperature Range			
						Standard	Low	Extreme Low	
All Models	All	2014/34/EU	Ex db h IIB T4 Gb Ex h tb IIIC T135 °C Db IP66/IP68	With or Without	Short time max 60 st/h	-20 to +85 °C / -4 to +185 °F	N/A	N/A	
Size 10-20-40-80-160	3-PH				Intermittent up to 200 St/h	-20 to +75 °C / -4 to +167 °F			
Size 10-20-40-80-160	1-PH / 110 V					All			-20 to +60 °C / -4 to +140 °F
Size 10-20-40-80-160	24 V DC								
Size 10-20-40-80-160-320-480	1-PH / 220 V								
All Models	All								

Base Version Features

Remote Controls

- 4 wires (OP, CL, Stop and C/latched)
- 3 wires (OP, CL, Stop and C/push -to-run or latched with instant reverse)
- 2 wires (No contact to open or reverse)

Control voltage

- 24 V DC, internal supply
- Not regulated Maximum 4 W
- 20 to 125 V DC, external supply
- 20 to 120 V AC, external supply
- Maximum 25 mA

Remote Output Contacts

Status

- Fully open
- Fully closed
- Position $\geq xx\%$
- Position $\leq xx\%$
- Closing
- Opening
- Motor running blinker
- Local selected
- Remote selected
- Local stop active
- PST active
- Manual operation

Alarms

- Motor over-temperature
- Over-torque
- Over torque in OP
- Over-torque in CL
- Valve jammed in OP
- Valve jammed in CL
- Valve jammed
- Warnings
- Low lithium battery (if present)
- Mid-travel alarm in CL/OP
- Mains-only AS8
- EFS in manual mode
- PST failed

Emergency Shutdown (ESD)

- Loss of main power
- Local selector in Off
- By an emergency local push button (Mushroom type)
- By remote hardwired command
- Local reset

Monitor Relay

- Loss of power
- Loss of one-phase
- Electrical contactor failure
- Local stop push-button pressed
- Local selector switch in Local/Off
- Internal temperature alarm
- Position sensor failure
- Hardware error
- Motor temperature alarm
- Torque alarm
- Jammed valve
- Mid-travel alarm
- Speed sensor failure
- Manual operation
- ESD action
- Low battery

Intelligent Protection

- Automatic phase correction
- Phase failure correction
- Motor thermostat
- Jammed valve protection
- Anti-hammer protection
- Instantaneous reversal protection

Warnings

- Contactor failure
- Maximum torque alarm
- Torque alarm by-pass
- High/low electronic temperature
- Opto-coupled remote controls

Valve Monitoring

Torque Profiles

- Breakout reference torque in opening
- Peak running reference torque in opening
- Ending reference torque in opening
- Breakout torque in opening
- Peak running torque in opening
- Ending torque in opening
- Breakout reference torque in closing
- Peak running reference torque in closing
- Ending reference torque in closing
- Breakout torque in closing
- Peak running torque in closing
- Ending torque in closing
- Date of the last 'set torque reference'
- Date of last torque profile in opening
- Date of last torque profile in closing

Operations

- Opening time of the last stroke
- Closing time of last stroke
- Total contactor operations
- Motor run time
- Time out without electrical power
- Utilization rate
- Torque alarm number
- Recent contactor operations
- Recent motor run time
- Recent time without electrical power
- Recent utilization rate

Alarms

- Last 64 alarms and date
- Last 64 warnings and date

Maintenance Data

- Last maintenance date
- Next maintenance date
- Date of the last clear recent data log
- Start-up date

PST Data

- Last PST report
- Next scheduled PST date
- PST initial signature (second/position)
- Last 100 PST profiles (second/position)

EFS Data

- Status
- Clutch coil status
- Manual/Auto selector status
- Card temperature
- Mushroom push-button status
- Heater status

Nameplate

- Serial number
- Actuator size
- Nominal torque
- Actuator speed
- Power supply
- Motor rating
- Motor duty
- Motor poles
- Motor type
- Motor current
- Test date
- Wiring diagram
- Enclosure
- Certificate
- Lubricant
- HW version
- SW version
- Torque set-up in opening
- Torque set-up in closing

Valve Data

- Valve tag name
- Valve serial number
- Valve manufacturer
- Break to open torque
- Maximum stem thrust
- Valve coupling type

Performance and Motor Data

EFS 3000 actuators can be supplied for single-phase, three-phase and DC power supplies. Performance and motor data is provided for the models indicated in the table below.

Table 7. Performance and Motor Data

Voltages	Power Supply			Model							
	Single-Phase	Three-Phase	DC	EFS 10	EFS 20	EFS 40	EFS80	EFS 160	EFS 320	EFS 480	EFS 960
24 V	-	-	✓	✓	✓	✓	✓	✓	-	-	-
110 V	*	-	-	✓	✓	✓	✓	✓	-	-	-
115 V	✓	-	-	✓	✓	✓	✓	✓	-	-	-
120 V	✓	-	-	✓	✓	✓	✓	✓	-	-	-
208 V	-	*	-	✓	✓	✓	✓	✓	-	-	-
220 V	✓	*	-	✓	✓	✓	✓	✓	-	-	-
230 V	✓	*	-	✓	✓	✓	✓	✓	Δ	Δ	*
240 V	✓	*	-	✓	✓	✓	✓	✓	Δ	Δ	*
280 V	-	*	-	✓	✓	✓	✓	✓	Δ	Δ	*
380 V	-	*	-	✓	✓	✓	✓	✓	Δ	Δ	*
400 V	-	✓	-	✓	✓	✓	✓	✓	Δ	Δ	*
415 V	-	*	-	✓	✓	✓	✓	✓	Δ	Δ	*
440 V	-	*	-	✓	✓	✓	✓	✓	Δ	Δ	*
460 V	-	*	-	✓	✓	✓	✓	✓	Δ	Δ	*
480 V	-	*	-	✓	✓	✓	✓	✓	Δ	Δ	*
500 V	-	*	-	✓	✓	✓	✓	✓	Δ	Δ	*
575 V	-	*	-	✓	✓	✓	✓	✓	Δ	Δ	*
690 V	-	*	-	✓	✓	✓	✓	✓	Δ	Δ	*

Notes:

- ✓ Available in the catalogue
- * Available on request
- Δ Available only with three-phase

For all performance and motor data, the following notes apply:

Voltages

The tolerances on all voltage values shown are ±10% (continuous), -15% to +10% (intermittent).

Nominal duties/duty ratings

Nominal duties are ±5% according to IEC 60034-1.

Nominal output power

Nominal output power (kW) is according to IEC 60034-1.

Motors

All performance data are based on Motor Class H.

Published values

The tolerances on published values are all according to IEC 60034-1.

Performance Single-Phase Supply 115 V 50 Hz - Spring to Close (CL) or Spring to Open (OP)

Table 8. On/Off S2-15', 60 Starts/hr or Inching S2-30', 200 Starts/hr

EFS Model	SET (N·m/lbf·ft) ⁽¹⁾	SST (N·m/lbf·ft) ⁽²⁾	MST (N·m/lbf·ft) ⁽³⁾	MET (N·m/lbf·ft) ⁽⁴⁾	ET (50 Hz) sec/90° ⁽⁵⁾	FST (sec/90°) ⁽⁶⁾	Maximum Set Actuator Output Torque (N·m/lbf·ft) ⁽⁷⁾
EFS 10-CL (OP)/93-SR1	93 / 69	130 / 96	150 / 111	110 / 82	From 30 to 63	From 2 to 20	384 / 283
EFS 20-CL (OP)/225-SR1	225 / 166	300 / 222	350 / 259	275 / 203	From 22 to 84	From 2 to 20	602 / 444
EFS 40-CL (OP)/450-SR1	450 / 332	610 / 450	680 / 502	520 / 384	From 44 to 169	From 3 to 30	1206 / 890
EFS 80-CL (OP)/900-SR1	850 / 627	1150 / 849	1250 / 922	900 / 664	From 44 to 169	From 3 to 30	2091 / 1543
EFS 160-CL (OP)/1800-SR1	1800 / 1328	2800 / 2066	2800 / 2066	1800 / 1328	From 105 to 402	From 3 to 30	4791 / 3534

Notes:

1. SET Spring ending torque at 90° (end to close for CL - end to open for OP).
2. SST Spring starting torque at 0° (start to close for CL - start to open for OP).
3. MST Electric Mode starting torque at 90° (start to open for CL - start to close for OP).
4. MET Electric Mode ending torque at 0° (end to open for CL - end to close for OP).
5. ET Time for stroke with electric motor at 50 Hz; multiply by 0.833 for 60 Hz supply.
6. FST fail-safe adjustable time.
7. The Maximum Set Actuator output torque is referred to the open/close maneuver done with the electric motor set @ 40% and the spring. Under no circumstances should the motor set torque of 40% in the closing/opening direction be changed or the torque by-pass be removed.

Table 9. On/Off S2-15', 60 Starts/hr or Inching S2-30', 200 Starts/hr

EFS Model	ICON Model	Motor Power (kW) ⁽⁸⁾	Motor Nominal Current (Inom) ⁽⁹⁾	Rated Current (Is) ⁽¹⁰⁾	Locked Rotor Current (Icc) ⁽¹¹⁾	Efficiency % Nominal	Power Factor ⁽¹²⁾	Absorbed Power (kW) ⁽¹³⁾
EFS 10-CL (OP)/93-SR1	010/30-SR1	0.106	3.15	5.74	9.70	32.2	0.91	330
EFS 20-CL (OP)/225-SR1	010/90-SR1	0.184	5.75	11.17	24.00	30.9	0.90	595
EFS 40-CL (OP)/450-SR1	010/90-SR1	0.184	5.75	11.17	24.00	30.9	0.90	595
EFS 80-CL (OP)/900-SR1	010/110-SR1	0.184	5.75	11.17	24.00	30.9	0.90	595
EFS 160-CL (OP)/1800-SR1	010/110-SR1	0.184	5.75	11.17	24.00	30.9	0.90	595

Notes:

Motor Voltage Operation

- Voltage at which the actuator must be able to supply its nominal torque and within the power supply.
- Tolerances ±10%
- Applies on Nominal torque performance only; duty cycle, speed and current draw is not guaranteed.

Motor Frequency Operation

- Frequency at which the actuator must be able to supply its nominal torque and within the frequency.
 - Tolerances ±10%
 - Applies on Nominal torque performance only; duty cycle, speed and current draw is not guaranteed.
8. Motor Output Power (kW) - Mechanical power output at motor shaft at run torque of multi-turn actuator. Approximately 40% of actuator rated torque, according to IEC 60034-1.
 9. Nominal current (Inom) - Current at run torque at approximately 40% of nominal torque (minimum torque).
 10. Rated current (Is) - Motor current at approximately 100% of actuator nominal torque.
 11. Locked Current (Icc) - Current at maximum torque (locked rotor current).
 12. Power Factor (Cosφ nom) - Power factor at approximately 40% of actuator nominal torque.
 13. Absorbed Power (kW) - Absorbed electrical power at approximately 40% of actuator nominal torque.

Performance Single-Phase Supply 120 V 60 Hz - Spring to Close (CL) or Spring to Open (OP)

Table 10. On/Off S2-15', 60 Starts/hr or Inching S2-30', 200 Starts/hr

EFS Model	SET (N·m/lbf·ft) ⁽¹⁾	SST (N·m/lbf·ft) ⁽²⁾	MST (N·m/lbf·ft) ⁽³⁾	MET (N·m/lbf·ft) ⁽⁴⁾	ET (50 Hz) sec/90° ⁽⁵⁾	FST (sec/90°) ⁽⁶⁾	Maximum Set Actuator Output Torque (N·m/lbf·ft) ⁽⁷⁾
EFS 10-CL (OP)/93-SR1	93 / 69	130 / 96	150 / 111	110 / 82	From 30 to 63	From 2 to 20	384 / 283
EFS 20-CL (OP)/225-SR1	225 / 166	300 / 222	350 / 259	275 / 203	From 22 to 84	From 2 to 20	602 / 444
EFS 40-CL (OP)/450-SR1	450 / 332	610 / 450	680 / 502	520 / 384	From 44 to 169	From 3 to 30	1206 / 890
EFS 80-CL (OP)/900-SR1	850 / 627	1150 / 849	1250 / 922	900 / 664	From 44 to 169	From 3 to 30	2091 / 1543
EFS 160-CL (OP)/1800-SR1	1800 / 1328	2800 / 2066	2800 / 2066	1800 / 1328	From 105 to 402	From 3 to 30	4791 / 3534

Notes:

1. SET Spring ending torque at 90° (end to close for CL - end to open for OP).
2. SST Spring starting torque at 0° (start to close for CL - start to open for OP).
3. MST Electric Mode starting torque at 90° (start to open for CL - start to close for OP).
4. MET Electric Mode ending torque at 0° (end to open for CL - end to close for OP).
5. ET Time for stroke with electric motor at 50 Hz; multiply by 0.833 for 60 Hz supply.
6. FST fail-safe adjustable time.
7. The Maximum Set Actuator output torque is referred to the open/close maneuver done with the electric motor set @ 40% and the spring. Under no circumstances should the motor set torque of 40% in the closing/opening direction be changed or the torque by-pass be removed.

Table 11. On/Off S2-15', 60 Starts/hr or Inching S2-30', 200 Starts/hr

EFS Model	ICON Model	Motor Power (kW) ⁽⁸⁾	Motor Nominal Current (Inom) ⁽⁹⁾	Rated Current (Is) ⁽¹⁰⁾	Locked Rotor Current (Icc) ⁽¹¹⁾	Efficiency % Nominal	Power Factor ⁽¹²⁾	Absorbed Power (kW) ⁽¹³⁾
EFS 10-CL (OP)/93-SR1	010/30-SR1	0.127	3.00	5.50	9.30	38.8	0.91	328
EFS 20-CL (OP)/225-SR1	010/90-SR1	0.221	5.50	10.70	23.00	37.2	0.90	594
EFS 40-CL (OP)/450-SR1	010/90-SR1	0.221	5.50	10.70	23.00	37.2	0.90	594
EFS 80-CL (OP)/900-SR1	010/110-SR1	0.221	5.50	10.70	23.00	37.2	0.90	594
EFS 160-CL (OP)/1800-SR1	010/110-SR1	0.221	5.50	10.70	23.00	37.2	0.90	594

Notes:

Motor Voltage Operation

- Voltage at which the actuator must be able to supply its nominal torque and within the power supply.
- Tolerances ±10%
- Applies on Nominal torque performance only; duty cycle, speed and current draw is not guaranteed.

Motor Frequency Operation

- Frequency at which the actuator must be able to supply its nominal torque and within the frequency.
 - Tolerances ±10%
 - Applies on Nominal torque performance only; duty cycle, speed and current draw is not guaranteed.
8. Motor Output Power (kW) - Mechanical power output at motor shaft at run torque of multi-turn actuator. Approximately 40% of actuator rated torque, according to IEC 60034-1.
 9. Nominal current (Inom) - Current at run torque at approximately 40% of nominal torque (minimum torque).
 10. Rated current (Is) - Motor current at approximately 100% of actuator nominal torque.
 11. Locked Current (Icc) - Current at maximum torque (locked rotor current).
 12. Power Factor (Cosφ nom) - Power factor at approximately 40% of actuator nominal torque.
 13. Absorbed Power (kW) - Absorbed electrical power at approximately 40% of actuator nominal torque.

Performance Single-Phase Supply 220 V 50 Hz - Spring to Close (CL) or Spring to Open (OP)

Table 12. On/Off S2-15', 60 Starts/hr or Inching S2-30', 200 Starts/hr

EFS Model	SET (N·m/lbf·ft) ⁽¹⁾	SST (N·m/lbf·ft) ⁽²⁾	MST (N·m/lbf·ft) ⁽³⁾	MET (N·m/lbf·ft) ⁽⁴⁾	ET (50 Hz) sec/90° ⁽⁵⁾	FST (sec/90°) ⁽⁶⁾	Maximum Set Actuator Output Torque (N·m/lbf·ft) ⁽⁷⁾
EFS 10-CL (OP)/93-SR1	93 / 69	130 / 96	150 / 111	110 / 82	From 30 to 63	From 2 to 20	384 / 283
EFS 20-CL (OP)/225-SR1	225 / 166	300 / 222	350 / 259	275 / 203	From 22 to 84	From 2 to 20	602 / 444
EFS 40-CL (OP)/450-SR1	450 / 332	610 / 450	680 / 502	520 / 384	From 44 to 169	From 3 to 30	1206 / 890
EFS 80-CL (OP)/900-SR1	850 / 627	1150 / 849	1250 / 922	900 / 664	From 44 to 169	From 3 to 30	2091 / 1543
EFS 160-CL (OP)/1800-SR1	1800 / 1328	2800 / 2066	2800 / 2066	1800 / 1328	From 105 to 402	From 3 to 30	4791 / 3534

Notes:

- SET Spring ending torque at 90° (end to close for CL - end to open for OP).
- SST Spring starting torque at 0° (start to close for CL - start to open for OP).
- MST Electric Mode starting torque at 90° (start to open for CL - start to close for OP).
- MET Electric Mode ending torque at 0° (end to open for CL - end to close for OP).
- ET Time for stroke with electric motor at 50 Hz; multiply by 0.833 for 60 Hz supply.
- FST fail-safe adjustable time.
- The Maximum Set Actuator output torque is referred to the open/close maneuver done with the electric motor set @ 40% and the spring. Under no circumstances should the motor set torque of 40% in the closing/opening direction be changed or the torque by-pass be removed.

Table 13. On/Off S2-15', 60 Starts/hr or Inching S2-30', 200 Starts/hr

EFS Model	ICON Model	Motor Power (kW) ⁽⁸⁾	Motor Nominal Current (Inom) ⁽⁹⁾	Rated Current (Is) ⁽¹⁰⁾	Locked Rotor Current (Icc) ⁽¹¹⁾	Efficiency % Nominal	Power Factor ⁽¹²⁾	Absorbed Power (kW) ⁽¹³⁾
EFS 10-CL (OP)/93-SR1	010/30-SR1	0.106	1.15	1.88	4.18	46.0	0.91	230
EFS 20-CL (OP)/225-SR1	010/90-SR1	0.184	3.35	5.75	12.02	27.8	0.90	662
EFS 40-CL (OP)/450-SR1	010/90-SR1	0.184	3.35	5.75	12.02	27.8	0.90	662
EFS 80-CL (OP)/900-SR1	010/110-SR1	0.184	3.35	5.75	12.02	27.8	0.90	662
EFS 160-CL (OP)/1800-SR1	010/110-SR1	0.184	3.35	5.75	12.02	27.8	0.90	662

Notes:

Motor Voltage Operation

- Voltage at which the actuator must be able to supply its nominal torque and within the power supply.
- Tolerances ±10%
- Applies on Nominal torque performance only; duty cycle, speed and current draw is not guaranteed.

Motor Frequency Operation

- Frequency at which the actuator must be able to supply its nominal torque and within the frequency.
 - Tolerances ±10%
 - Applies on Nominal torque performance only; duty cycle, speed and current draw is not guaranteed.
- Motor Output Power (kW) - Mechanical power output at motor shaft at run torque of multi-turn actuator. Approximately 40% of actuator rated torque, according to IEC 60034-1.
 - Nominal current (Inom) - Current at run torque at approximately 40% of nominal torque (minimum torque).
 - Rated current (Is) - Motor current at approximately 100% of actuator nominal torque.
 - Locked Current (Icc) - Current at maximum torque (locked rotor current).
 - Power Factor (Cosφ nom) - Power factor at approximately 40% of actuator nominal torque.
 - Absorbed Power (kW) - Absorbed electrical power at approximately 40% of actuator nominal torque.

Performance Single-Phase Supply 230 V 50 Hz - Spring to Close (CL) or Spring to Open (OP)

Table 14. On/Off S2-15', 60 Starts/hr or Inching S2-30', 200 Starts/hr

EFS Model	SET (N·m/lbf·ft) ⁽¹⁾	SST (N·m/lbf·ft) ⁽²⁾	MST (N·m/lbf·ft) ⁽³⁾	MET (N·m/lbf·ft) ⁽⁴⁾	ET (50 Hz) sec/90° ⁽⁵⁾	FST (sec/90°) ⁽⁶⁾	Maximum Set Actuator Output Torque (N·m/lbf·ft) ⁽⁷⁾
EFS 10-CL (OP)/93-SR1	93 / 69	130 / 96	150 / 111	110 / 82	From 30 to 63	From 2 to 20	384 / 283
EFS 20-CL (OP)/225-SR1	225 / 166	300 / 222	350 / 259	275 / 203	From 22 to 84	From 2 to 20	602 / 444
EFS 40-CL (OP)/450-SR1	450 / 332	610 / 450	680 / 502	520 / 384	From 44 to 169	From 3 to 30	1206 / 890
EFS 80-CL (OP)/900-SR1	850 / 627	1150 / 849	1250 / 922	900 / 664	From 44 to 169	From 3 to 30	2091 / 1543
EFS 160-CL (OP)/1800-SR1	1800 / 1328	2800 / 2066	2800 / 2066	1800 / 1328	From 105 to 402	From 3 to 30	4791 / 3534

Notes:

1. SET Spring ending torque at 90° (end to close for CL - end to open for OP).
2. SST Spring starting torque at 0° (start to close for CL - start to open for OP).
3. MST Electric Mode starting torque at 90° (start to open for CL - start to close for OP).
4. MET Electric Mode ending torque at 0° (end to open for CL - end to close for OP).
5. ET Time for stroke with electric motor at 50 Hz; multiply by 0.833 for 60 Hz supply.
6. FST fail-safe adjustable time.
7. The Maximum Set Actuator output torque is referred to the open/close maneuver done with the electric motor set @ 40% and the spring. Under no circumstances should the motor set torque of 40% in the closing/opening direction be changed or the torque by-pass be removed.

Table 15. On/Off S2-15', 60 Starts/hr or Inching S2-30', 200 Starts/hr

EFS Model	ICON Model	Motor Power (kW) ⁽⁸⁾	Motor Nominal Current (Inom) ⁽⁹⁾	Rated Current (Is) ⁽¹⁰⁾	Locked Rotor Current (Icc) ⁽¹¹⁾	Efficiency % Nominal	Power Factor ⁽¹²⁾	Absorbed Power (kW) ⁽¹³⁾
EFS 10-CL (OP)/93-SR1	010/30-SR1	0.106	1.10	1.80	4.00	46.0	0.91	230
EFS 20-CL (OP)/225-SR1	010/90-SR1	0.184	3.20	5.50	11.50	27.8	0.90	662
EFS 40-CL (OP)/450-SR1	010/90-SR1	0.184	3.20	5.50	11.50	27.8	0.90	662
EFS 80-CL (OP)/900-SR1	010/110-SR1	0.184	3.20	5.50	11.50	27.8	0.90	662
EFS 160-CL (OP)/1800-SR1	010/110-SR1	0.184	3.20	5.50	11.50	27.8	0.90	662

Notes:

Motor Voltage Operation

- Voltage at which the actuator must be able to supply its nominal torque and within the power supply.
- Tolerances ±10%
- Applies on Nominal torque performance only; duty cycle, speed and current draw is not guaranteed.

Motor Frequency Operation

- Frequency at which the actuator must be able to supply its nominal torque and within the frequency.
 - Tolerances ±10%
 - Applies on Nominal torque performance only; duty cycle, speed and current draw is not guaranteed.
8. Motor Output Power (kW) - Mechanical power output at motor shaft at run torque of multi-turn actuator. Approximately 40% of actuator rated torque, according to IEC 60034-1.
 9. Nominal current (Inom) - Current at run torque at approximately 40% of nominal torque (minimum torque).
 10. Rated current (Is) - Motor current at approximately 100% of actuator nominal torque.
 11. Locked Current (Icc) - Current at maximum torque (locked rotor current).
 12. Power Factor (Cosφ nom) - Power factor at approximately 40% of actuator nominal torque.
 13. Absorbed Power (kW) - Absorbed electrical power at approximately 40% of actuator nominal torque.

Performance Single-Phase Supply 240 V 50 Hz - Spring to Close (CL) or Spring to Open (OP)

Table 16. On/Off S2-15', 60 Starts/hr or Inching S2-30', 200 Starts/hr

EFS Model	SET (N·m/lbf·ft) ⁽¹⁾	SST (N·m/lbf·ft) ⁽²⁾	MST (N·m/lbf·ft) ⁽³⁾	MET (N·m/lbf·ft) ⁽⁴⁾	ET (50 Hz) sec/90° ⁽⁵⁾	FST (sec/90°) ⁽⁶⁾	Maximum Set Actuator Output Torque (N·m/lbf·ft) ⁽⁷⁾
EFS 10-CL (OP)/93-SR1	93 / 69	130 / 96	150 / 111	110 / 82	From 30 to 63	From 2 to 20	384 / 283
EFS 20-CL (OP)/225-SR1	225 / 166	300 / 222	350 / 259	275 / 203	From 22 to 84	From 2 to 20	602 / 444
EFS 40-CL (OP)/450-SR1	450 / 332	610 / 450	680 / 502	520 / 384	From 44 to 169	From 3 to 30	1206 / 890
EFS 80-CL (OP)/900-SR1	850 / 627	1150 / 849	1250 / 922	900 / 664	From 44 to 169	From 3 to 30	2091 / 1543
EFS 160-CL (OP)/1800-SR1	1800 / 1328	2800 / 2066	2800 / 2066	1800 / 1328	From 105 to 402	From 3 to 30	4791 / 3534

Notes:

1. SET Spring ending torque at 90° (end to close for CL - end to open for OP).
2. SST Spring starting torque at 0° (start to close for CL - start to open for OP).
3. MST Electric Mode starting torque at 90° (start to open for CL - start to close for OP).
4. MET Electric Mode ending torque at 0° (end to open for CL - end to close for OP).
5. ET Time for stroke with electric motor at 50 Hz; multiply by 0.833 for 60 Hz supply.
6. FST fail-safe adjustable time.
7. The Maximum Set Actuator output torque is referred to the open/close maneuver done with the electric motor set @ 40% and the spring. Under no circumstances should the motor set torque of 40% in the closing/opening direction be changed or the torque by-pass be removed.

Table 17. On/Off S2-15', 60 Starts/hr or Inching S2-30', 200 Starts/hr

EFS Model	ICON Model	Motor Power (kW) ⁽⁸⁾	Motor Nominal Current (Inom) ⁽⁹⁾	Rated Current (Is) ⁽¹⁰⁾	Locked Rotor Current (Icc) ⁽¹¹⁾	Efficiency % Nominal	Power Factor ⁽¹²⁾	Absorbed Power (kW) ⁽¹³⁾
EFS 10-CL (OP)/93-SR1	010/30-SR1	0.127	1.27	2.07	4.60	46.0	0.91	276
EFS 20-CL (OP)/225-SR1	010/90-SR1	0.221	3.68	6.33	13.23	27.8	0.90	795
EFS 40-CL (OP)/450-SR1	010/90-SR1	0.221	3.68	6.33	13.23	27.8	0.90	795
EFS 80-CL (OP)/900-SR1	010/110-SR1	0.22	3.68	6.33	13.23	27.8	0.90	795
EFS 160-CL (OP)/1800-SR1	010/110-SR1	0.221	3.68	6.33	13.23	27.8	0.90	795

Notes:

Motor Voltage Operation

- Voltage at which the actuator must be able to supply its nominal torque and within the power supply.
- Tolerances ±10%
- Applies on Nominal torque performance only; duty cycle, speed and current draw is not guaranteed.

Motor Frequency Operation

- Frequency at which the actuator must be able to supply its nominal torque and within the frequency.
 - Tolerances ±10%
 - Applies on Nominal torque performance only; duty cycle, speed and current draw is not guaranteed.
8. Motor Output Power (kW) - Mechanical power output at motor shaft at run torque of multi-turn actuator. Approximately 40% of actuator rated torque, according to IEC 60034-1.
 9. Nominal current (Inom) - Current at run torque at approximately 40% of nominal torque (minimum torque).
 10. Rated current (Is) - Motor current at approximately 100% of actuator nominal torque.
 11. Locked Current (Icc) - Current at maximum torque (locked rotor current).
 12. Power Factor (Cosφ nom) - Power factor at approximately 40% of actuator nominal torque.
 13. Absorbed Power (kW) - Absorbed electrical power at approximately 40% of actuator nominal torque.

Performance Three-Phase Supply 400 V 50 Hz - Spring to Close (CL) or Spring to Open (OP)

Table 18. On/Off S2-15', 60 Starts/hr or Inching S2-30', 200 Starts/hr Models EFS 10 to EFS 80

EFS Model	SET (N·m/lbf·ft) ⁽¹⁾	SST (N·m/lbf·ft) ⁽²⁾	MST (N·m/lbf·ft) ⁽³⁾	MET (N·m/lbf·ft) ⁽⁴⁾	ET (50 Hz) sec/90° ⁽⁵⁾	FST (sec/90°) ⁽⁶⁾	Maximum Set Actuator Output Torque (N·m/lbf·ft) ⁽⁷⁾
EFS 10 CL (OP)/93-41	93 / 69	130 / 96	150 / 111	110 / 82	41	From 2 to 20	260 / 191
EFS 10 CL (OP)/93-21	93 / 69	130 / 96	150 / 111	110 / 82	21	From 2 to 20	295 / 217
EFS 10 CL (OP)/93-14	93 / 69	130 / 96	150 / 111	110 / 82	14	From 2 to 20	295 / 217
EFS 10 CL (OP)/93-7	93 / 69	130 / 96	150 / 111	110 / 82	7	From 2 to 20	295 / 217
EFS 20 CL (OP)/225-41	225 / 166	300 / 222	350 / 259	275 / 203	41	From 2 to 20	658 / 485
EFS 20 CL (OP)/225-21	225 / 166	300 / 222	350 / 259	275 / 203	21	From 2 to 20	578 / 426
EFS 20 CL (OP)/225-14	225 / 166	300 / 222	350 / 259	275 / 203	14	From 2 to 20	667 / 491
EFS 20 CL (OP)/225-7	225 / 166	300 / 222	350 / 259	275 / 203	7	From 2 to 20	575 / 424
EFS 40 CL (OP)/450-83	450 / 332	610 / 450	680 / 501	520 / 383	83	From 3 to 30	1253 / 924
EFS 40 CL (OP)/450-41	450 / 332	610 / 450	680 / 501	520 / 383	41	From 3 to 30	1110 / 818
EFS 40 CL (OP)/450-28	450 / 332	610 / 450	680 / 501	520 / 383	28	From 3 to 30	1270 / 936
EFS 40 CL (OP)/450-14	450 / 332	610 / 450	680 / 501	520 / 383	14	From 3 to 30	1105 / 815
EFS 80 CL (OP)/900-83	850 / 627	1150 / 849	1250 / 921	900 / 663	83	From 3 to 30	1793 / 1323
EFS 80 CL (OP)/900-55 *	850 / 627	1150 / 849	1250 / 921	900 / 663	55	From 3 to 30	2090 / 1542
EFS 80 CL (OP)/900-28	850 / 627	1150 / 849	1250 / 921	900 / 663	28	From 3 to 30	2090 / 1541
EFS 80 CL (OP)/900-14	850 / 627	1150 / 849	1250 / 921	900 / 663	14	From 3 to 30	2103 / 1551

Notes:

1. SET Spring ending torque at 90° (end to close for CL - end to open for OP).
2. SST Spring starting torque at 0° (start to close for CL - start to open for OP).
3. MST Electric Mode starting torque at 90° (start to open for CL - start to close for OP).
4. MET Electric Mode ending torque at 0° (end to open for CL - end to close for OP).
5. ET Time for stroke with electric motor at 50 Hz; multiply by 0.833 for 60 Hz supply.
6. FST fail-safe adjustable time.
7. The Maximum Set Actuator output torque is referred to the open/close maneuver done with the electric motor set @ 40% and the spring. Under no circumstances should the motor set torque of 40% in the closing/opening direction be changed or the torque by-pass be removed.
* Motor Service limited to S2-10'.

Table 19. On/Off S2-15', 60 Starts/hr or Inching S2-30', 200 Starts/hr Models EFS 10 to EFS 80

EFS Model	ICON Model	Motor Power (kW) ⁽⁸⁾	Motor RPM	Motor Nominal Current (Inom) ⁽⁹⁾	Rated Current (Is) ⁽¹⁰⁾	Locked Rotor Current (Icc) ⁽¹¹⁾	Efficiency % Nominal	Power Factor ⁽¹²⁾	Absorbed Power (kW) ⁽¹³⁾
EFS 10 CL (OP)/93-41	010 / 25-9	0.030	475	0.47	0.52	0.70	20.0	0.46	150
EFS 10 CL (OP)/93-21	010 / 25-18	0.140	950	0.97	1.32	2.90	45.3	0.46	309
EFS 10 CL (OP)/93-14	010 / 25-27	0.280	1440	1.10	1.71	4.75	65.6	0.56	427
EFS 10 CL (OP)/93-7	010 / 25-54	0.420	2880	1.25	2.36	6.90	68.3	0.71	615
EFS 20 CL (OP)/225-41	010 / 50-9	0.070	480	1.60	1.85	2.50	14.7	0.43	477
EFS 20 CL (OP)/225-21	010 / 50-18	0.140	950	0.97	1.32	2.90	45.3	0.46	309
EFS 20 CL (OP)/225-14	010 / 50-27	0.280	1440	1.10	1.71	4.75	65.6	0.56	427
EFS 20 CL (OP)/225-7	010 / 50-54	0.420	2880	1.25	2.36	6.90	68.3	0.71	615
EFS 40 CL (OP)/450-83	010 / 60-9	0.070	480	1.60	1.85	2.50	14.7	0.43	477
EFS 40 CL (OP)/450-41	010 / 60-18	0.140	950	0.97	1.32	2.90	45.3	0.46	309
EFS 40 CL (OP)/450-28	010 / 60-27	0.280	1440	1.10	1.71	4.75	65.6	0.56	427
EFS 40 CL (OP)/450-14	010 / 60-54	0.420	2880	1.25	2.36	6.90	68.3	0.71	615
EFS 80 CL (OP)/900-83	010 / 110-9	0.070	480	1.60	1.85	2.50	14.7	0.43	477
EFS 80 CL (OP)/900-55 *	010 / 110-14	0.185	715	1.90	2.26	4.40	34.3	0.41	540
EFS 80 CL (OP)/900-28	010 / 110-27	0.365	1450	1.90	2.63	7.80	59.0	0.47	619
EFS 80 CL (OP)/900-14	010 / 110-54	0.740	2900	2.35	4.76	13.00	75.8	0.60	977

Notes:

Motor Voltage Operation

- Voltage at which the actuator must be able to supply its nominal torque and within the power supply.
- Tolerances ±10%
- Applies on Nominal torque performance only; duty cycle, speed and current draw is not guaranteed.

Motor Frequency Operation

- Frequency at which the actuator must be able to supply its nominal torque and within the frequency.
- Tolerances ±10%
- Applies on Nominal torque performance only; duty cycle, speed and current draw is not guaranteed.

- Motor Output Power (kW) - Mechanical power output at motor shaft at run torque of multi-turn actuator. Approximately 40% of actuator rated torque, according to IEC 60034-1.
- Nominal current (Inom) - Current at run torque at approximately 40% of nominal torque (minimum torque).
- Rated current (Is) - Motor current at approximately 100% of actuator nominal torque.
- Locked Current (Icc) - Current at maximum torque (locked rotor current).
- Power Factor (Cosφ nom) - Power factor at approximately 40% of actuator nominal torque.
- Absorbed Power (kW) - Absorbed electrical power at approximately 40% of actuator nominal torque.

* Motor Service limited to S2-10'.

Performance Three-Phase Supply 400 V 50 Hz - Spring to Close (CL) or Spring to Open (OP)

Table 20. On/Off S2-15', 60 Starts/hr or Inching S2-30', 200 Starts/hr Models EFS 160 to EFS 960

EFS Model	SET (N•m/lbf•ft) ⁽¹⁾	SST (N•m/lbf•ft) ⁽²⁾	MST (N•m/lbf•ft) ⁽³⁾	MET (N•m/lbf•ft) ⁽⁴⁾	ET (50 Hz) sec/90° ⁽⁵⁾	FST (sec/90°) ⁽⁶⁾	Maximum Set Actuator Output Torque (N•m/lbf•ft) ⁽⁷⁾
EFS 160 CL (OP)/1800-197	1800 / 1328	2800 / 2066	2800 / 2065	1800 / 1327	197	From 3 to 30	4162 / 3069
EFS 160 CL (OP)/1800-131 *	1800 / 1328	2800 / 2066	2800 / 2065	1800 / 1327	131	From 3 to 30	4790 / 3533
EFS 160 CL (OP)/1800-98	1800 / 1328	2800 / 2066	2800 / 2065	1800 / 1327	98	From 3 to 30	4536 / 3345
EFS 160 CL (OP)/1800-66	1800 / 1328	2800 / 2066	2800 / 2065	1800 / 1327	66	From 3 to 30	4789 / 3532
EFS 160 CL (OP)/1800-33	1800 / 1328	2800 / 2066	2800 / 2065	1800 / 1327	33	From 3 to 30	4816 / 3552
EFS 320 CL (OP)/3600-103	3600 / 2656	5400 / 3983	5400 / 3982	3600 / 2655	103	From 3 to 30	8687 / 6407
EFS 320 CL (OP)/3600-69	3600 / 2656	5400 / 3983	5400 / 3982	3600 / 2655	69	From 3 to 30	8685 / 6405
EFS 320 CL (OP)/3600-34	3600 / 2656	5400 / 3983	5400 / 3982	3600 / 2655	34	From 3 to 30	8462 / 6241
EFS 480 CL (OP)/4500-103	4500 / 3319	7800 / 5753	5800 / 4277	3600 / 2655	103	From 3 to 30	11087 / 8177
EFS 480 CL (OP)/4500-69	4500 / 3319	7800 / 5753	5800 / 4277	3600 / 2655	69	From 3 to 30	11085 / 8176
EFS 480 CL (OP)/4500-34	4500 / 3319	7800 / 5753	5800 / 4277	3600 / 2655	34	From 3 to 30	10862 / 8011
EFS 960 CL (OP)/9000-136 **	8000 / 5900	12150 / 8960	18600 / 13718	12500 / 9219	136	From 5 to 45	**
EFS 960 CL (OP)/9000-91 **	8000 / 5900	12150 / 8960	18600 / 13718	12500 / 9219	91	From 5 to 45	**
EFS 960 CL (OP)/9000-45 **	8000 / 5900	12150 / 8960	18600 / 13718	12500 / 9219	45	From 5 to 45	**

Notes:

1. SET Spring ending torque at 90° (end to close for CL - end to open for OP).
2. SST Spring starting torque at 0° (start to close for CL - start to open for OP).
3. MST Electric Mode starting torque at 90° (start to open for CL - start to close for OP).
4. MET Electric Mode ending torque at 0° (end to open for CL - end to close for OP).
5. ET Time for stroke with electric motor at 50 Hz; multiply by 0.833 for 60 Hz supply.
6. FST fail-safe adjustable time.
7. The Maximum Set Actuator output torque is referred to the open/close maneuver done with the electric motor set @ 40% and the spring. Under no circumstances should the motor set torque of 40% in the closing/opening direction be changed or the torque by-pass be removed.
* Motor Service limited to S2-10'.
** Contact Factory.

Table 21. On/Off S2-15', 60 Starts/hr or Inching S2-30', 200 Starts/hr Models EFS 160 to EFS 960

EFS Model	ICON Model	Motor Power (kW) ⁽⁸⁾	Motor RPM	Motor Nominal Current (Inom) ⁽⁹⁾	Rated Current (Is) ⁽¹⁰⁾	Locked Rotor Current (Icc) ⁽¹¹⁾	Efficiency % Nominal	Power Factor ⁽¹²⁾	Absorbed Power (kW) ⁽¹³⁾
EFS 160 CL (OP)/1800-197	010/110-9	0.070	480	1.60	1.85	2.50	14.7	0.43	477
EFS 160 CL (OP)/1800-131 *	010/110-14	0.185	715	1.90	2.26	4.40	34.3	0.41	540
EFS 160 CL (OP)/1800-98	010/110-18	0.290	960	1.45	2.07	5.50	61.4	0.47	472
EFS 160 CL (OP)/1800-66	010/110-27	0.365	1450	1.90	2.63	7.80	59.0	0.47	619
EFS 160 CL (OP)/1800-33	010/110-54	0.740	2900	2.35	4.76	13.00	75.8	0.60	977
EFS 320 CL (OP)/3600-103	020/210-18	0.520	950	2.70	3.57	9.10	57.9	0.48	898
EFS 320 CL (OP)/3600-69	020/210-27	0.780	1430	2.80	4.48	12.50	68.1	0.59	1145
EFS 320 CL (OP)/3600-34	020/210-54	1.470	2900	3.90	6.92	21.00	85.0	0.64	1729
EFS 480 CL (OP)/4500-103	020/240-18	0.520	950	2.70	3.57	9.10	57.9	0.48	898
EFS 480 CL (OP)/4500-69	020/240-27	0.780	1430	2.80	4.48	12.50	68.1	0.59	1145
EFS 480 CL (OP)/4500-34	020/240-54	1.470	2900	3.90	6.92	21.00	85.0	0.64	1729
EFS 960 CL (OP)/9000-136 **	030/400-18	0.520	950	2.70	3.57	9.10	57.9	0.48	898
EFS 960 CL (OP)/9000-91 **	030/400-27	0.780	1430	2.80	4.48	12.50	68.1	0.59	1145
EFS 960 CL (OP)/9000-45 **	030/400-54	1.470	2900	3.90	6.92	21.00	85.0	0.64	1729

Notes:

Motor Voltage Operation

- Voltage at which the actuator must be able to supply its nominal torque and within the power supply.
- Tolerances ±10%
- Applies on Nominal torque performance only; duty cycle, speed and current draw is not guaranteed.

Motor Frequency Operation

- Frequency at which the actuator must be able to supply its nominal torque and within the frequency.
 - Tolerances ±10%
 - Applies on Nominal torque performance only; duty cycle, speed and current draw is not guaranteed.
8. Motor Output Power (kW) - Mechanical power output at motor shaft at run torque of multi-turn actuator. Approximately 40% of actuator rated torque, according to IEC 60034-1.
 9. Nominal current (Inom) - Current at run torque at approximately 40% of nominal torque (minimum torque).
 10. Rated current (Is) - Motor current at approximately 100% of actuator nominal torque.
 11. Locked Current (Icc) - Current at maximum torque (locked rotor current).
 12. Power Factor (Cosφ nom) - Power factor at approximately 40% of actuator nominal torque.
 13. Absorbed Power (kW) - Absorbed electrical power at approximately 40% of actuator nominal torque.

* Motor Service limited to S2-10'.

** Contact Factory.

Performance DC Supply 24 V - Spring to Close (CL) or Spring to Open (OP)

Table 22. On/Off S2-15', 60 Starts/hr, or Inching S2-30', 200 Starts/hr

EFS Model	SET (N·m/lbf·ft) ⁽¹⁾	SST (N·m/lbf·ft) ⁽²⁾	MST (N·m/lbf·ft) ⁽³⁾	MET (N·m/lbf·ft) ⁽⁴⁾	ET (50 Hz) sec/90° ⁽⁵⁾	FST (sec/90°) ⁽⁶⁾	Maximum Set Actuator Output Torque (N·m/lbf·ft) ⁽⁷⁾
EFS 10 CL (OP)/93-SR1	93 / 69	130 / 96	150 / 111	110/82	From 17 to 42	From 2 to 20	212 / 156
EFS 20 CL (OP)/225-SR1	225 / 166	300 / 222	350 / 259	275/203	From 17 to 42	From 2 to 20	495 / 365
EFS 40 CL (OP)/450-SR1	450 / 332	610 / 450	680 / 502	520/384	From 34 to 84	From 3 to 30	994 / 733
EFS 80 CL (OP)/900-SR1	850 / 627	1150 / 849	1250 / 922	900/664	From 34 to 84	From 3 to 30	1865 / 1375
EFS 160 CL (OP)/1800-SR1	1800 / 1328	2800 / 2066	2800 / 2066	1800/1328	From 80 to 201	From 3 to 30	4360 / 3215

Notes:

1. SET Spring ending torque at 90° (end to close for CL - end to open for OP).
2. SST Spring starting torque at 0° (start to close for CL - start to open for OP).
3. MST Electric Mode starting torque at 90° (start to open for CL - start to close for OP).
4. MET Electric Mode ending torque at 0° (end to open for CL - end to close for OP).
5. ET Time for stroke with electric motor at 50 Hz; multiply by 0.833 for 60 Hz supply.
6. FST fail-safe adjustable time.
7. The Maximum Set Actuator output torque is referred to the open/close maneuver done with the electric motor set @ 40% and the spring. Under no circumstances should the motor set torque of 40% in the closing/opening direction be changed or the torque by-pass be removed.

Table 23. On/Off S2-15', 60 Starts/hr or Inching S2-30', 200 Starts/hr

EFS Model	ICON Model	Motor Power (kW) ⁽⁸⁾	Motor Nominal Current (Inom) ⁽⁹⁾	Rated Current (Is) ⁽¹⁰⁾	Locked Rotor Current (Icc) ⁽¹¹⁾	Power Factor ⁽¹²⁾	Absorbed Power (kW) ⁽¹³⁾
EFS 10 CL (OP)/93-SR1	010/30-SR1	0.400	19.00	19.40	125.00	0.88	456
EFS 20 CL (OP)/225-SR1	010/90-SR1	0.400	22.00	33.00	125.00	0.76	528
EFS 40 CL (OP)/450-SR1	010/90-SR1	0.400	22.00	33.00	125.00	0.76	528
EFS 80 CL (OP)/900-SR1	010/110-SR1	0.400	22.00	33.00	125.00	0.76	528
EFS 160 CL (OP)/1800-SR1	010/110-SR1	0.400	22.00	33.00	125.00	0.76	528

Notes:

Motor Voltage Operation

- Voltage at which the actuator must be able to supply its nominal torque and within the power supply.
- Tolerances ±10%
- Applies on Nominal torque performance only; duty cycle, speed and current draw is not guaranteed.

Motor Frequency Operation

- Frequency at which the actuator must be able to supply its nominal torque and within the frequency.
 - Tolerances ±10%
 - Applies on Nominal torque performance only; duty cycle, speed and current draw is not guaranteed.
8. Motor Output Power (kW) - Mechanical power output at motor shaft at run torque of multi-turn actuator. Approximately 40% of actuator rated torque, according to IEC 60034-1.
 9. Nominal current (Inom) - Current at run torque at approximately 40% of nominal torque (minimum torque).
 10. Rated current (Is) - Motor current at approximately 100% of actuator nominal torque.
 11. Locked Current (Icc) - Current at maximum torque (locked rotor current).
 12. Power Factor (Cosφ nom) - Power factor at approximately 40% of actuator nominal torque.
 13. Absorbed Power (kW) - Absorbed electrical power at approximately 40% of actuator nominal torque.

Overall Actuator Dimensions

Spring to Close

Figure 3. EFS 3000 General Arrangement Dimensions

Notes:

Standard cable entries:

a - 1 in. NPT

b - 1-1/2 in. NPT

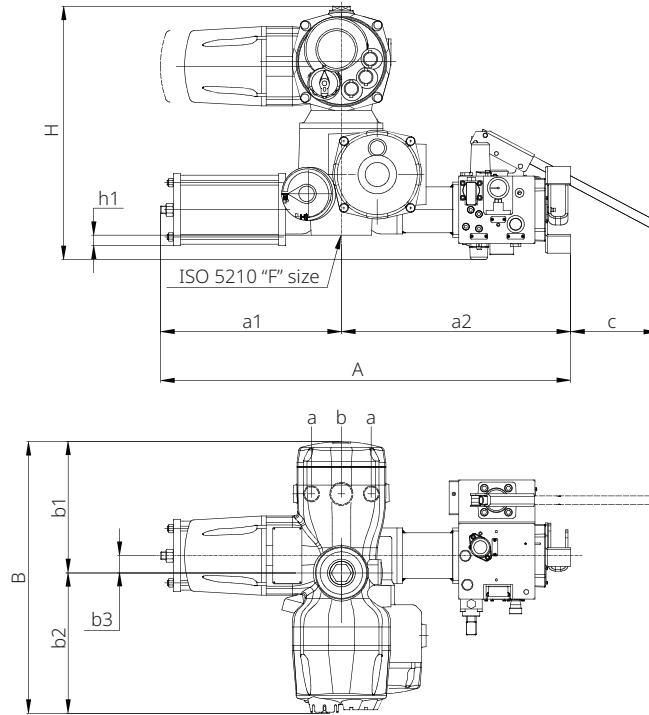

Table 24. Dimensions in Metric (mm)

Model	A	a1	a2	B	b1	b2	b3	C	H	h1	kg
EFS 10-CL	835	460	374	561	273	288	36	180	524	21	130
EFS 20-CL	829	454	374	561	273	288	36	180	524	24	170
EFS 40-CL	1076	539	536	561	273	288	65	180	512	27	177
EFS 80-CL	1070	535	536	561	273	288	65	180	534	55	160
EFS 160-CL	1413	665	748	639	287	352	125	180	575	50	290
EFS 320-CL	1741	796	945	734	349	385	164	180	794	61	468
EFS 480-CL	1741	796	945	734	349	385	164	180	794	85	480
EFS 960-CL	2151	974	1177	974	489	485	204	180	952	181	880

Table 25. Dimensions in Imperial (in.)

Model	A	a1	a2	B	b1	b2	b3	C	H	h1	lb
EFS 10-CL	32.9	18.1	14.7	22.1	10.7	11.3	1.4	7.09	20.6	0.8	287
EFS 20-CL	32.6	17.9	14.7	22.1	10.7	11.3	1.4	7.09	20.6	0.9	375
EFS 40-CL	42.4	21.2	21.1	22.1	10.7	11.3	2.6	7.09	20.2	1.1	390
EFS 80-CL	42.1	21.1	21.1	22.1	10.7	11.3	2.6	7.09	21.0	2.2	353
EFS 160-CL	55.6	26.2	29.4	25.2	11.3	13.9	4.9	7.09	22.6	2.0	639
EFS 320-CL	68.5	31.3	37.2	28.9	13.7	15.2	6.5	7.09	31.3	2.4	1032
EFS 480-CL	68.5	31.3	37.2	28.9	13.7	15.2	6.5	7.09	31.3	3.3	1058
EFS 960-CL	84.7	38.3	46.3	38.3	19.3	19.1	8.0	7.09	37.5	7.1	1940

Spring to Open

Figure 4. EFS 3000 General Arrangement Dimensions

Notes:

Standard cable entries:

a - 1 in. NPT

b - 1-1/2 in. NPT

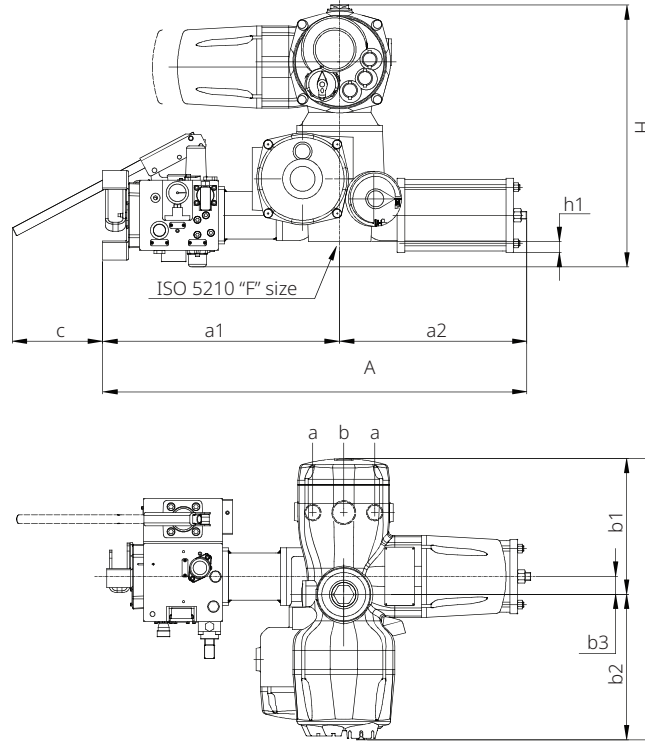

Table 26. Dimensions in Metric (mm)

Model	A	a1	a2	B	b1	b2	b3	C	H	h1	kg
EFS 10-OP	835	460	374	561	273	288	36	180	524	21	130
EFS 20-OP	829	454	374	561	273	288	36	180	524	24	170
EFS 40-OP	1076	539	536	561	273	288	65	180	512	27	177
EFS 80-OP	1070	535	536	561	273	288	65	180	534	55	160
EFS 160-OP	1413	665	748	639	287	352	125	180	575	50	290
EFS 320-OP	1741	796	945	734	349	385	164	180	794	61	468
EFS 480-OP	1741	796	945	734	349	385	164	180	794	85	480
EFS 960-OP	2151	974	1177	974	489	485	204	180	952	181	880

Table 27. Dimensions in Imperial (in.)

Model	A	a1	a2	B	b1	b2	b3	C	H	h1	lb
EFS 10-OP	32.9	18.1	14.7	22.1	10.7	11.3	1.4	7.09	20.6	0.8	287
EFS 20-OP	32.6	17.9	14.7	22.1	10.7	11.3	1.4	7.09	20.6	0.9	375
EFS 40-OP	42.4	21.2	21.1	22.1	10.7	11.3	2.6	7.09	20.2	1.1	390
EFS 80-OP	42.1	21.1	21.1	22.1	10.7	11.3	2.6	7.09	21.0	2.2	353
EFS 160-OP	55.6	26.2	29.4	25.2	11.3	13.9	4.9	7.09	22.6	2.0	639
EFS 320-OP	68.5	31.3	37.2	28.9	13.7	15.2	6.5	7.09	31.3	2.4	1032
EFS 480-OP	68.5	31.3	37.2	28.9	13.7	15.2	6.5	7.09	31.3	3.3	1058
EFS 960-OP	84.7	38.3	46.3	38.3	19.3	19.1	8.0	7.09	37.5	7.1	1940

Output Drive Dimensions Spring to Close

Figure 5. EFS 3000 Mounting Pattern

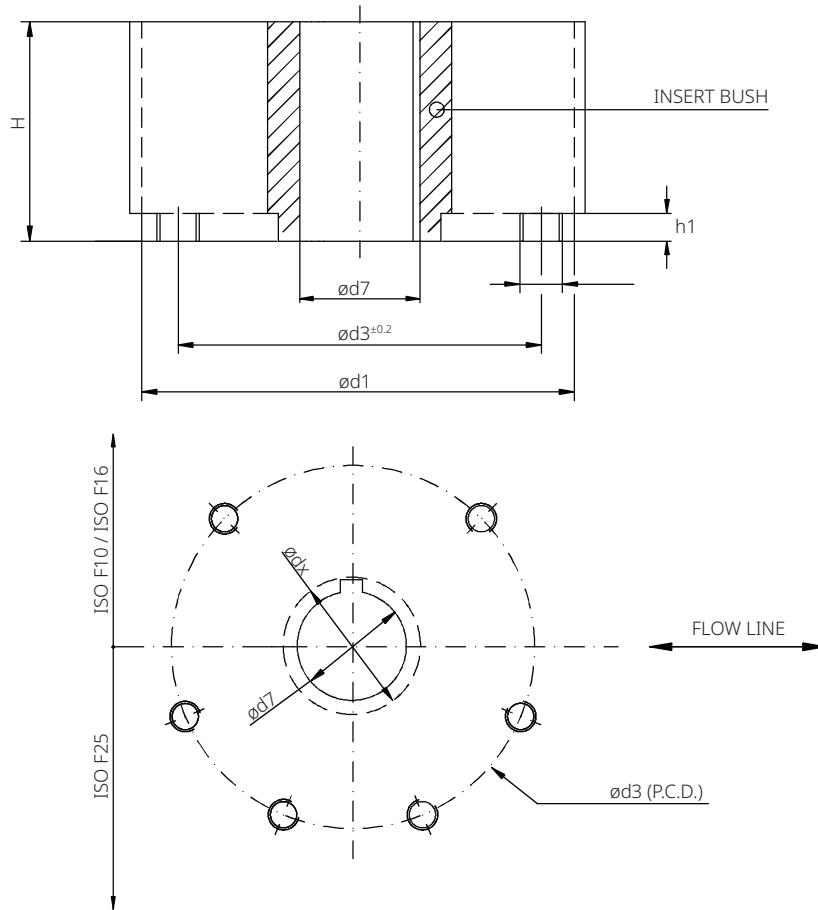

Table 28. Dimensions in Metric (mm)

Model	ISO 5211	ød1	ød3	ød4	N	H min	h1	d7 Maximum Stem Acceptance Insert Bush	
								ød7	ødx
EFS 10	F10	125	102	M10	4	50	20	25	35
EFS 20	F10	125	102	M10	4	50	20	25	35
EFS 40	F14	175	140	M16	4	89	25	42	51
EFS 80	F14	175	140	M16	4	89	25	42	51
EFS 160	F16	210	165	M20	4	105	30	65	76
EFS 320	F25	300	254	M16	8	130	25	90	104
EFS 480	F25	300	254	M16	8	130	25	90	104
EFS 960	F30	350	298	M20	8	165	30	103	120

Notes

1. Insert bush supplied by Biffi with unmachined bore. Machining of bore upon request.
2. Fixing bolts or rods supplied by Biffi only on request, minimum material class required 8.8 UNI37409, ASTM A320-L7.
3. Any other coupling can be supplied on request.

Wiring Diagram Code

Data applicable to the multi-turn actuator model EFS 3000_V2.

Coding Chart									
Part Number	W	D	9	6	V	T	B	Y1	Y2
EFS 3000 Electric Fail-Safe Actuator									
Control Type and Motor Duty						V			
Short-time duty (S2-15') Inching duty (S4-25% 60 St/h) Local CONTROL						A			
Short-time duty (S2-15') Inching duty (S4-25% 60 St/h) Local CONTROL 4 to 20 mA OUT						B			
Short-time duty (S2-15') Inching duty (S4-25% 60 St/h) Local CONTROL 4 to 20 mA IN/OUT						C			
Inching duty (S4-25% 200 St/h) Local CONTROL						N			
Inching duty (S4-25% 200 St/h) Local CONTROL 4 to 20 mA OUT						E			
Inching duty (S4-25% 200 St/h) Local CONTROL 4 to 20 mA IN/OUT						M			
Power Supply						T			
Direct Current						C			
Single-Phase						M			
Three-Phase						T			
Control Options						B			
Hard-wired (Basic)						0			
LonWorks						A			
PROFIBUS DP V1						G			
PROFIBUS DP V1 redundant						K			
PROFIBUS DP V2 Redundant						L			
Modbus redundant						V			
Modbus single channel with repeater						W			
Modbus single channel (RDM ready)						R			
FOUNDATION Fieldbus						N			
HART 7						H			
HART 7 - Wireless connectivity						T			
Accessories								Y1	Y2
Basic								0	0

This page is intentionally left blank.

<https://www.biffi.it/en-us>

FCDS-20174-EN © 2026 Biffi. All rights reserved. All other marks are the property of their respective owners.

Neither Emerson nor any of its affiliated entities assume responsibility for the selection, use or maintenance of any product. Responsibility for proper selection, use, and maintenance of any product remains solely with the purchaser and end user.

The contents of this publication are presented for informational purposes only, and while every effort has been made to ensure their accuracy, they are not to be construed as warranties or guarantees, express or implied, regarding the products or services described herein or their use or applicability. All sales are governed by our terms and conditions, which are available upon request. We reserve the right to modify or improve the designs or specifications of such products at any time without notice.

