

ALGA

DOUBLE ACTING PNEUMATIC ACTUATOR

MAN 564



Use and maintenance manual

5	27/03/18	Revised Data-plate	<i>Ermanni</i>	<i>Orefici</i>	<i>Vigliano</i>
4	18/04/16	Updated applicable regulation (chapter 1.1.1)	<i>Ermanni</i>	<i>Orefici</i>	<i>Vigliano</i>
3	15/04/13	Revised chapter 5.1.1	<i>Ermanni</i>	<i>Stato</i>	<i>Vigliano</i>
2	13/01/11	Revised sectional dwg	<i>Ermanni</i>	<i>Stato</i>	<i>Vigliano</i>
1	17/11/10	General update	<i>Ermanni</i>	<i>Stato</i>	<i>Vigliano</i>
Rev.	Date	Description	Prepared	Checked	Approved

TABLE OF CONTENTS

1	General warnings	4
1.1	Generalities	4
	1.1.1 <i>Applicable regulation</i>	4
	1.1.2 <i>Terms and conditions</i>	4
1.2	Identification plate	5
1.3	INTRODUCING THE ACTUATOR	5
1.4	DATA SHEET	6
2	Installation	6
2.1	CHECKS UPON ACTUATOR RECEIPT	6
2.2	ACTUATOR HANDLING	7
2.3	STORAGE	10
2.4	ACTUATOR ASSEMBLY ON THE VALVE	10
	2.4.1 <i>Types of assembly</i>	10
	2.4.2 <i>Assembly procedure</i>	19
2.5	PNEUMATIC CONNECTIONS	20
2.6	ELECTRICAL CONNECTIONS (IF ANY)	20
2.7	COMMISSIONING	22
3	Operation and use	23
3.1	OPERATION DESCRIPTION	23
3.2	RESIDUAL RISKS	27
3.3	CALIBRATION OF THE ANGULAR STROKE	30
3.4	CALIBRATION OF MICROSWITCHES (biffi limit switch box only)	32
3.5	CALIBRATION OF THE OPERATION TIME	33
4	Operational tests and inspections	35
5	Maintenance	36
5.1	PERIODIC MAINTENANCE	36
	5.1.2 <i>Gas supply dehydrating filter maintenance (if foreseen)</i>	39
5.2	EXTRAORDINARY MAINTENANCE	39
5.3	MHP maintenance and trouble shooting	48
	5.3.1 <i>Operation</i>	48
	5.3.2 <i>Manual operation</i>	48
	5.3.3 <i>Remote operation</i>	48
	5.3.4 <i>Setting</i>	49
	A) <i>Setting of the actuator operating times</i>	49
	B) <i>Settings of relief valves</i>	50
5.4	Lubrication of mechanism	53
5.4	DISMANTLING AND DEMOLITION	54
6	Troubleshooting	55
6.1	FAILURE OR BREAKDOWN RESEARCH	55
7	Layouts	56
7.1	Spare parts order	56
7.2	parts-list for maintenance and replacing procedure	57
8	Date report for maintenance operations	66

NOTE:

BIFFI Italia S.r.l. pays the highest attention to collecting and verifying the documentation contained in this user manual. However BIFFI Italia S.r.l. is not liable for any mistakes contained in this manual, for damage or accidents due to the use of the latter. The information contained is of exclusive reserved ownership of BIFFI Italia S.r.l and may be modified without prior notice. All rights reserved.

1 General warnings



The manual is an integral part of the machine, it should be carefully read before carrying out any operation and it should be kept for future references.

1.1 GENERALITIES

BIFFI Italia S.r.l actuators are conceived, manufactured and controlled according to the Quality Control System in compliance with EN-ISO 9001 international regulation.

1.1.1 *Applicable regulation*

EN ISO 12100:2010: **Safety of machinery – General principles for design – Risk assessment and risk reduction**

2006/42/EC: **Machine directive.**

2014/68/EU: **Directive for pressure PED equipment**

2014/35/EU: **Directive for low voltage equipment**

2014/30/EU: **Directive for the electromagnetic compatibility**

2014/34/EU: **Directive and safety instructions for use in hazardous area**

1.1.2 *Terms and conditions*



Biffi Italia srl guarantees that all the items produced are free of defects in workmanship and manufacturing materials and meet relevant current specifications, provided they are installed, used and serviced according to the instructions contained in the present manual. The warranty can last either one year from the date of installation by the initial user of the product, or eighteen months from the date of shipment to the initial user, depending on which event occurs first. All detailed warranty conditions are specified in the documentation forwarded together with the product. This warranty does not cover special products or components not warranted by subcontractors, or materials that were used or installed improperly or were modified or repaired by unauthorized staff. In the event that a fault condition be caused by improper installation, maintenance or use, or by irregular working conditions, the repairs will be charged according to applicable fees. **The warranty and Biffi Italia srl liability shall lapse in the event that any modification or tampering whatsoever be performed on the actuator.**

1.2 IDENTIFICATION PLATE



It is forbidden to modify the information and the marks without previous written authorization by BIFFI Italia S.r.l.

The plate fastened on the actuator contains the following information (Picture1).

		BIFFI ITALIA Fiorenzuola d' Arda 29017(PC) - ITALY	
ORDER _____			
MODEL _____			
S/N _____		AMB. TEMP. _____	
TAG N° _____		ND _____	
SUPPLY PRES. RANGE _____		MOP _____	
FL. GROUP _____	PED CAT. _____	FL. TYPE _____	
CYL. PS _____	CYL. TS _____	MM/YYYY _____	
CYL.PT _____	TEST DATE _____	CYL WEIGHT _____	
	Ref.: _____	LY: _____	
		ISO _____	

Picture 1 – Data plate

1.3 INTRODUCING THE ACTUATOR

The ALGA actuators was engineered and is manufactured to provide maximum torque output with minimum supply pressure. Alga actuators are suitable for the operation of any quarter turn operation such of ball, plug, butterfly valves or dampers, in both On-Off and Modulating heavy duty service.

The actuator (see picture 2) is made up of a weatherproof scotch yoke mechanism transforming the linear movement of the pneumatic cylinder (on closing or opening) into the rotary movement, which is necessary for operation. The angular stroke of the yoke is adjustable between 82° and 98° by means of the external mechanical stops screwed into the left wall of the mechanism housing and into the end flange of the pneumatic cylinder. The cover of the scotch yoke mechanism is arranged for the assembly of the required accessories (positioner, signalling limit switches, position transducer, etc.) by means of proper matching units. The above mentioned accessories are operated by the actuator drive sleeve. The housing of the scotch yoke mechanism has a flange with threaded holes to fix the actuator to the valve either directly or, if required, with the interposition of an adaptor flange or a mounting bracket. The actuator yoke has a hole with keyways suitable for the assembly of an insert bush the internal

hole of which is machined (by BIFFI or at Customer's care), according to the shape and dimensions of the valve stem. BIFFI can supply different types of control system following Customer's requirements.

The expected lifetime of actuator is approximately 25 years .

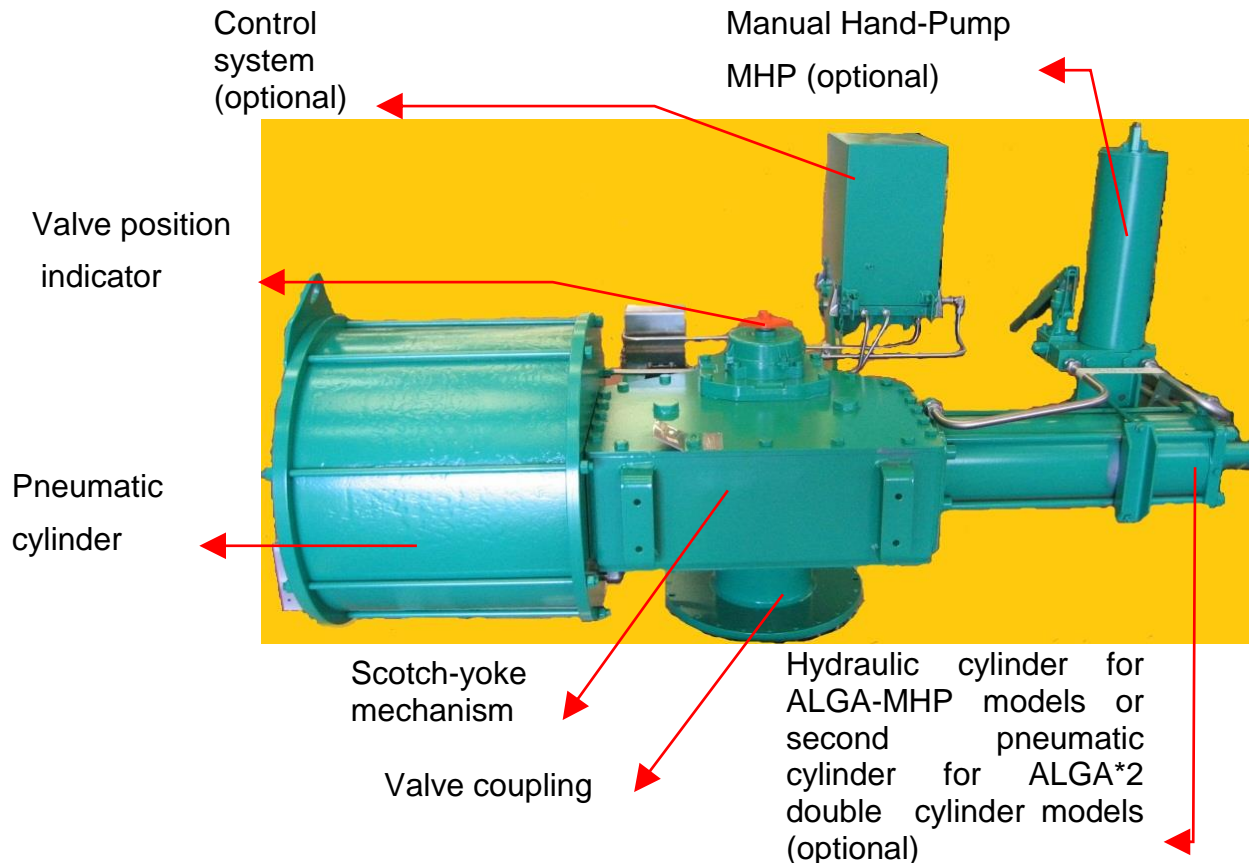

Picture 2 – Identification of actuator parts

1.4 DATA SHEET

Supply fluid	Air, nitrogen or sweet gas, special version available for sour gas
Operating temperature	Standard: from -30°C to $+100^{\circ}\text{C}$ Optional: from -60° to $+200^{\circ}\text{C}$
Supply pressure	Please refer to technical document: "actuator data-sheet"
Output torque	Up to 750000 Nm (higher value with special version)

2 Installation

2.1 CHECKS UPON ACTUATOR RECEIPT

- Check that the model, the serial number of the actuator and the

technical data reported on the identification plate correspond with those of order confirmation (Sect. 1.2).

- Check that the actuator is equipped with the fittings as provided for by order confirmation.
- Check that the actuator was not damaged during transportation: if necessary renovate the painting according to the specification reported on the order confirmation.
- If the actuator is received already assembled with the valve, its settings have already been made at the factory.

If the actuator is delivered separately from the valve, it is necessary to check, and, if required, to adjust, the settings of the mechanical stops (Sect. 3.4) and of micro-switches (if any) (Sect. 3.5).

2.2 ACTUATOR HANDLING



The lifting and handling should be made by qualified staff and in compliance with the laws and provisions in force.



The fastening points are appropriate for the lifting of the actuator alone and not for the valve + actuator assembly. Avoid that during the handling, the actuator passes above the staff. The actuator should be handled with appropriate lifting means. The weight of the actuator is reported on the delivery bill.

For lifting and moving the actuator, use only hooks fitted with safety latch, like the one, for example, shown in follow figure 2.1

Figure 2.1 Example of hook with safety latch



Picture 3 – Lifting points for ALGA / ALGA-MHP / ALGA-MSJ actuators

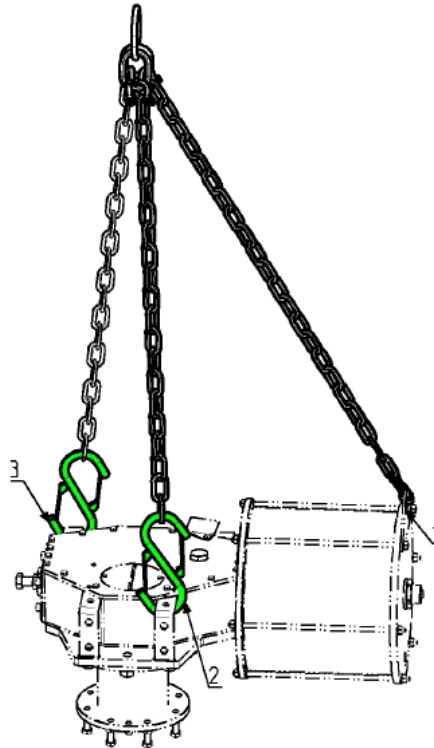

1-2 = Lifting points (obligatory) 3 = Balancing point

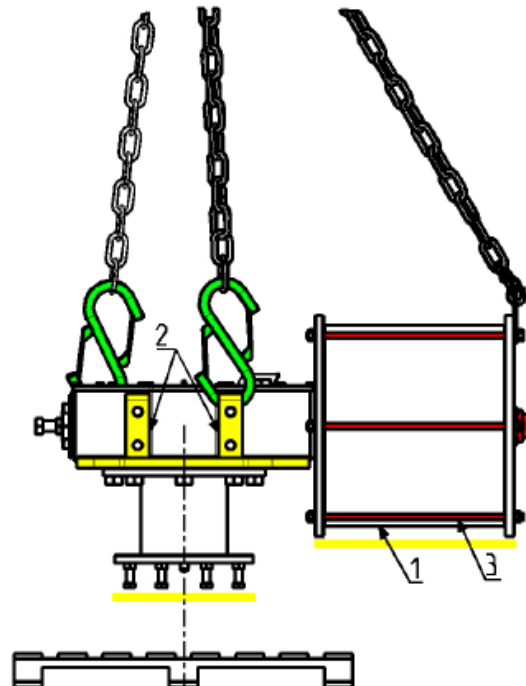

1 = point of support - 2 = supports for lateral positioning

3 = don't lay the actuator on tie-rods of cylinder /s and

don't lay the actuator on accessories (manual hand-pump, manual jack-screw, pneumatic control group etc.)

- **For lifting unbalanced loads, use ropes of different lengths or chains with adjustable length.**



- Check each time the conditions of all lifting equipment used and discard it if not in perfect working order.
- Do not knot or twist the ropes so as not to reduce the lifting capacity or produce torsional effects on the load being lifted.
- Use the utmost caution and remain at a safe distance from lifted actuator unless absolutely necessary; do not stand or pass under suspended loads.
- Pay attention in putting under tension the ropes to prevent the load shifting sideways in an uncontrolled manner.
- Use slings of such length that the angles of the leg from vertical are as narrow as possible ($\alpha_{MAX} < 20^\circ$).
- During handling, do not transport the suspended actuator above staff members in charge of the operation.



DO NOT USE the lifting eyelets on actuator to lift valve + actuator assembly

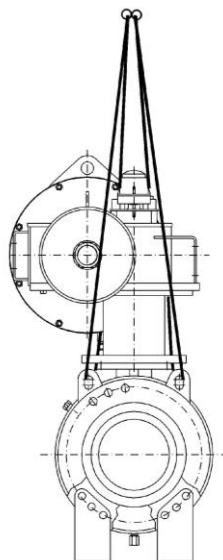
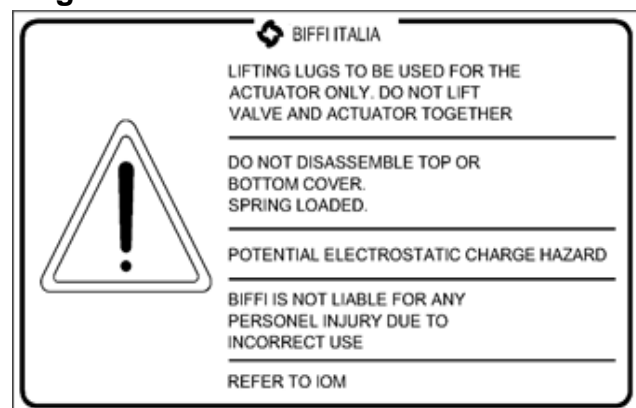

Figure 2.4



Any lifting method different from what described above is strictly forbidden.

BIFFI reject any responsibility for damages to goods or injuries to persons coming from wrong lifting operations.

2.3 STORAGE

If the actuator needs storage, before installation follow these steps:

- Place it on a wood surface in order not to deteriorate the area of valve coupling.
- Make sure that plastic plugs are present on the pneumatic and electrical connections (if present).
- Check that the cover of the control group and of the limit switch box (if any) are properly closed.

If the storage is long-term or outdoor:

- Keep the actuator protected from direct weather conditions.
- Replace plastic plugs of pneumatic and electrical connections (if any) with metal plugs that guarantee perfect tightness.
- Coat with oil, grease or protection disc, the valve coupling area.
- Periodically operate the actuator (Sect. 3.3).

2.4 ACTUATOR ASSEMBLY ON THE VALVE

2.4.1 Types of assembly

For coupling to the valve, the housing is provided with a flange with threaded holes according to Biffi standard tables (SCN6200; SCN6200-1; SCN6201; SCN6201-1 SCN6201-3 SCN6201-5) . The number, dimensions and diameter of the holes are made in accordance with ISO 5211, but for actuator models 0.3 to 6 the holes are drilled on the centreline in order to allow an easier assembly of an intermediate flange, when required. This intermediate flange (or spool-piece) can be supplied when the valve flange can not directly match the actuator flange in its “standard” configuration. For the biggest actuator models, the actuator flange can be machined in accordance with the valve flange dimensions.

The yoke has bored with keyways for coupling to the valve stem, the dimensions of which are according to Biffi standard tables SCN6200*- and SCN6201*:

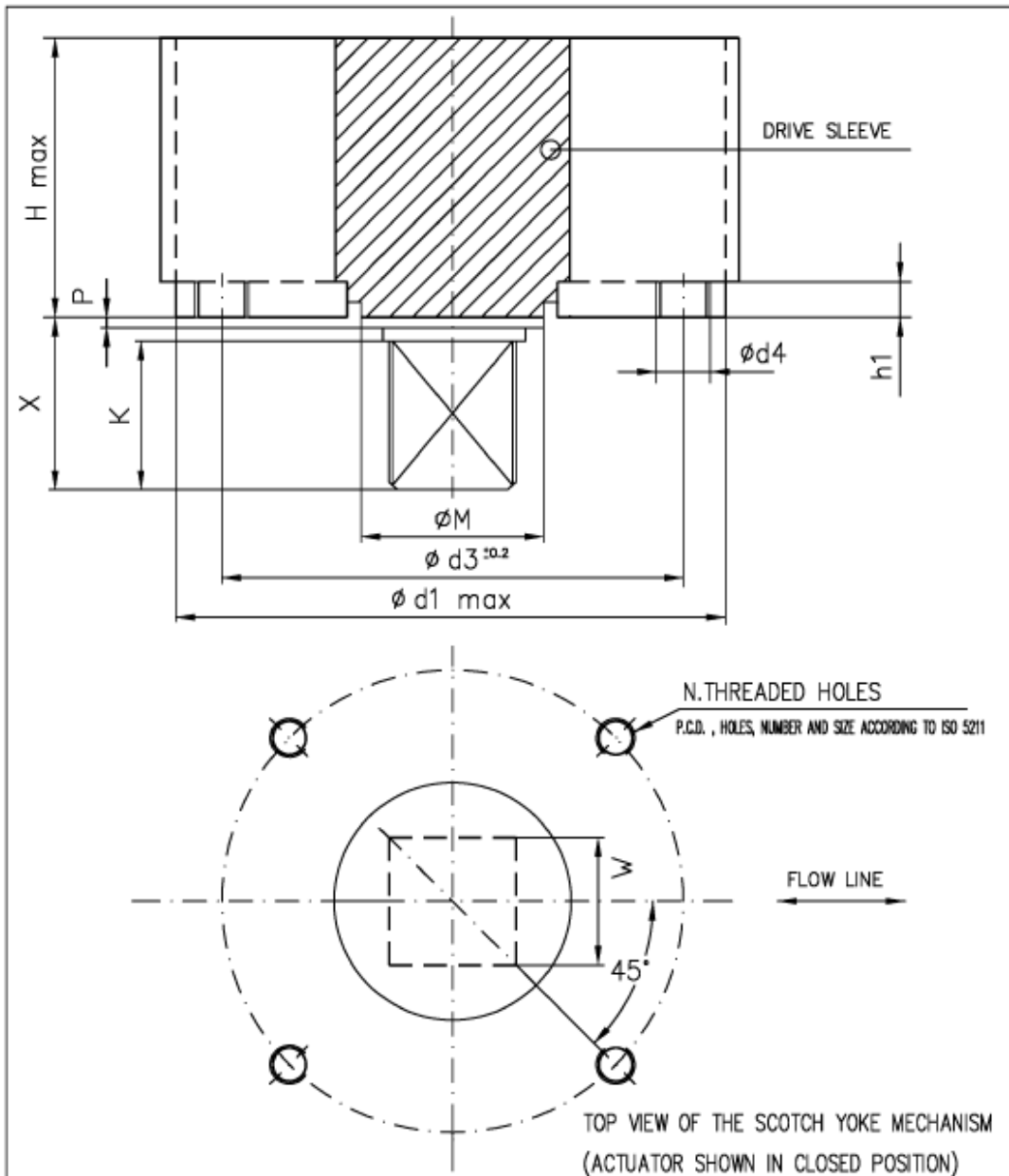

DIMENSIONS ARE IN MILLIMETERS

ACTUATOR MODEL	∅d1	∅d3	∅d4	∅M	N	P	h1	H max	W	K	X
0.1	220	102	M10	50	4	7	17	121	22	25	32

2	15/10/19	R.Riso	S.Orefici	Notes threaded holes revision							
1	18/06/12	NL	MS	Revisionata quota "X" (ex 36)							
Mod.	Data	Eseguita	Approvata	Descrizione Modifica							
		COUPLING DIMENSIONS FOR SCOTCH YOKE STANDARD ACTUATORS - FOR MODEL 0,1 -						Disegno Numero SCN 6200-1			
		Scala /		Data 13/10/04		Disegnato EE		Approvato FC			

Del presente disegno e' valida solamente la copia con ultima modifica

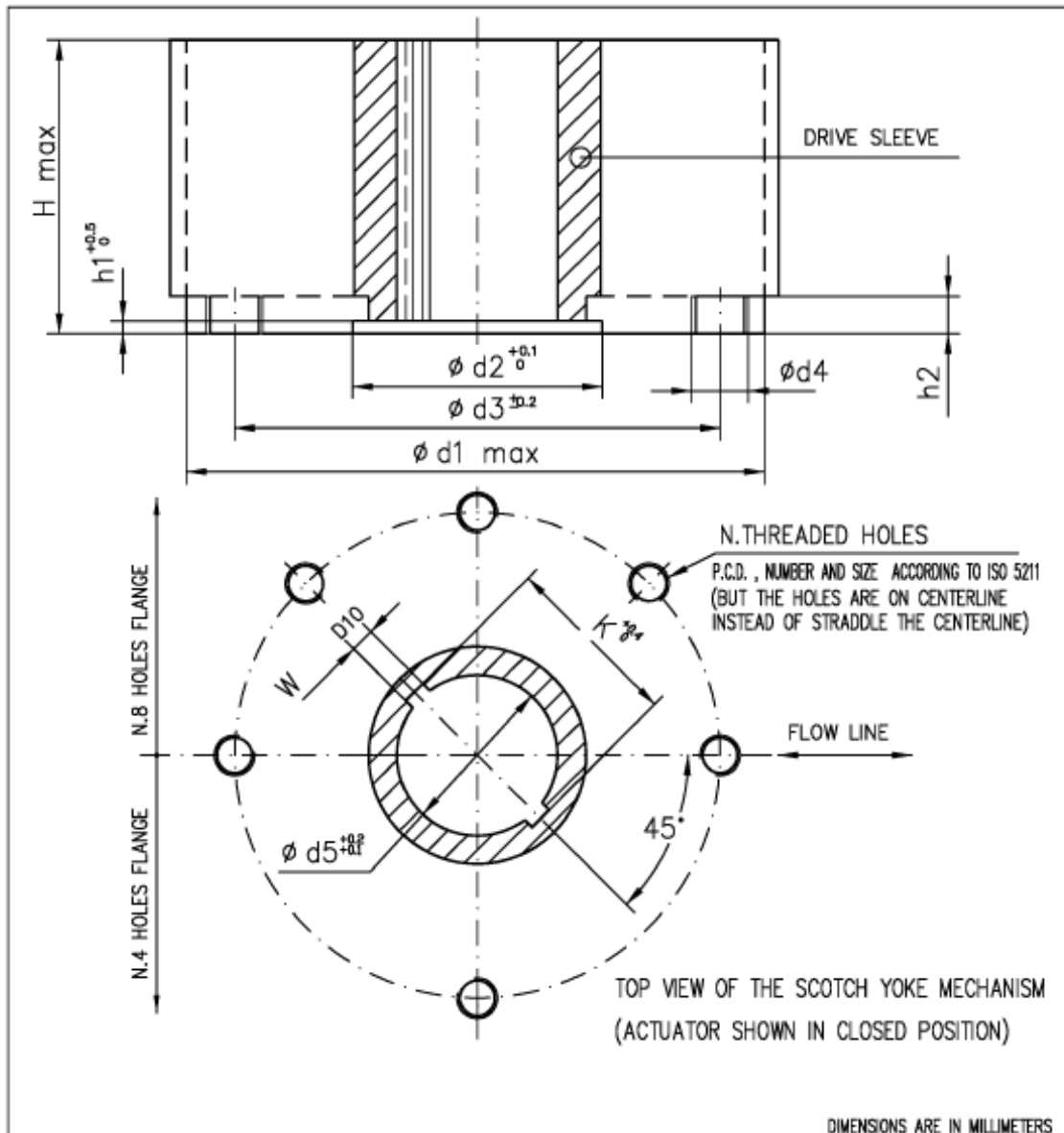

ACTUATOR MODEL	$\phi d1$	$\phi d2$	$\phi d3$	$\phi d4$	N	h1	h2	H max	$\phi d5$	W	K
0.3	240	93	165	M20	4	5	17	127	70	12	75.6
0.9	310	112	254	M16	8	5	19	150	86	14	93.6
1.5	360	144	298	M20	8	6	19	190	112	18	119
3	430	195	356	M30	8	9	23	200	157	25	167.8
6	520	250	406	M36	8	14	29	260	200	28	212.8

01	15/10/19	Riso	Orefici	Notes threaded holes revision
Mod.	Data	Eseguita	Approvata	Descrizione Modifica

 BIFFI <small>ATTUATORI E SISTEMI DI CONTROLLO VALVE ACTUATORS AND CONTROL SYSTEMS</small>	COUPLING DIMENSIONS FOR SCOTCH YOKE STANDARD ACTUATORS - MODELS FROM 0.3 TO 6 -		Disegno Numero SCN 6200	
	Scala /	Data	21/12/89	
	Disegnato	Approvato		

Del presente disegno e' valida solamente la copia con ultima modifica

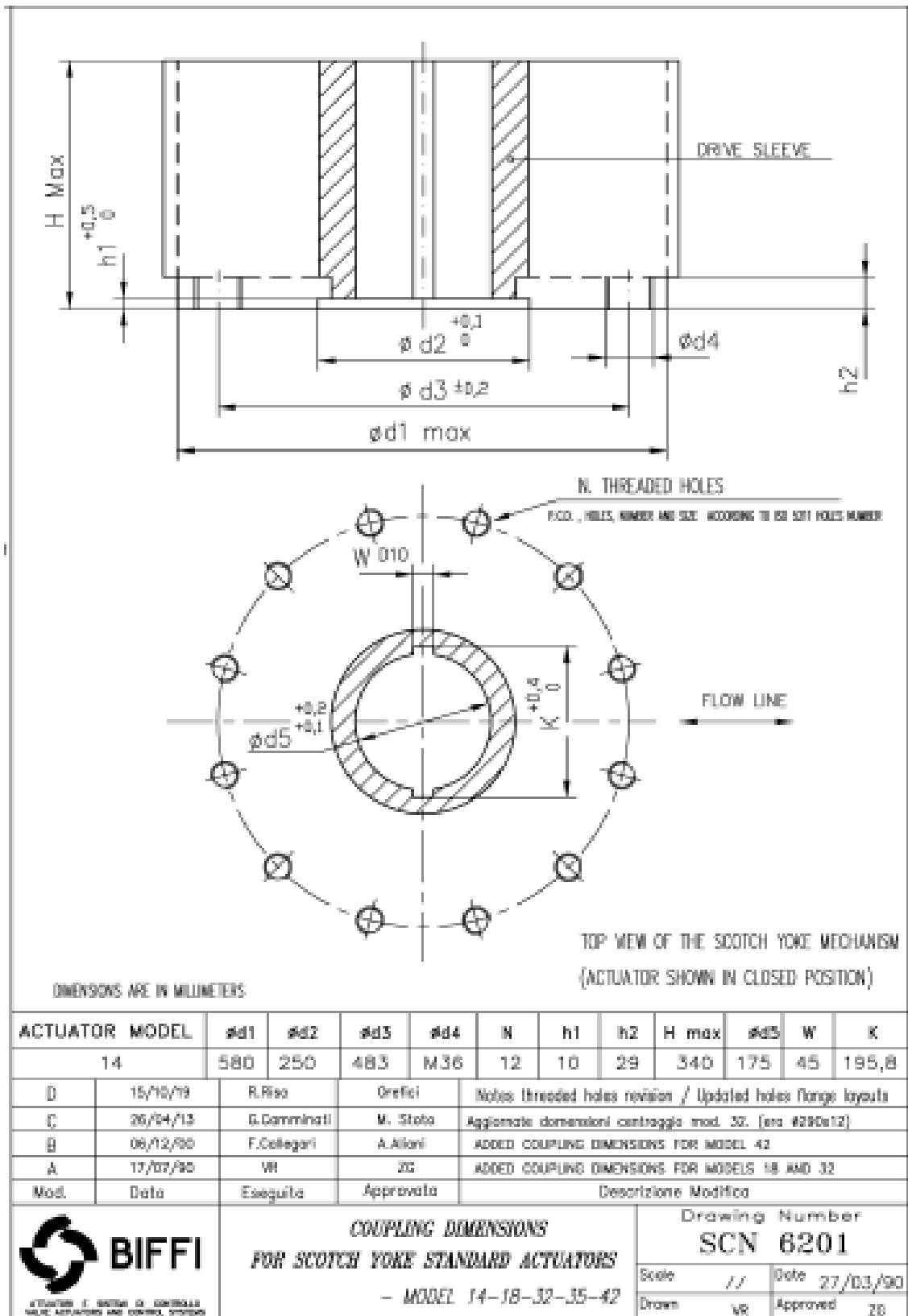

Drawing valid only in last revision copy

This document is Company property. This Company reserves all rights in terms of law



COUPLING DIMENSIONS
FOR SCOTCH YOKE STANDARD ACTUATORS
 - MODEL 14-18-32-35-42

Drawing Number	
SCN 6201	
Scale	1/1
Date	27/03/90
Drawn	vg
Approved	zg

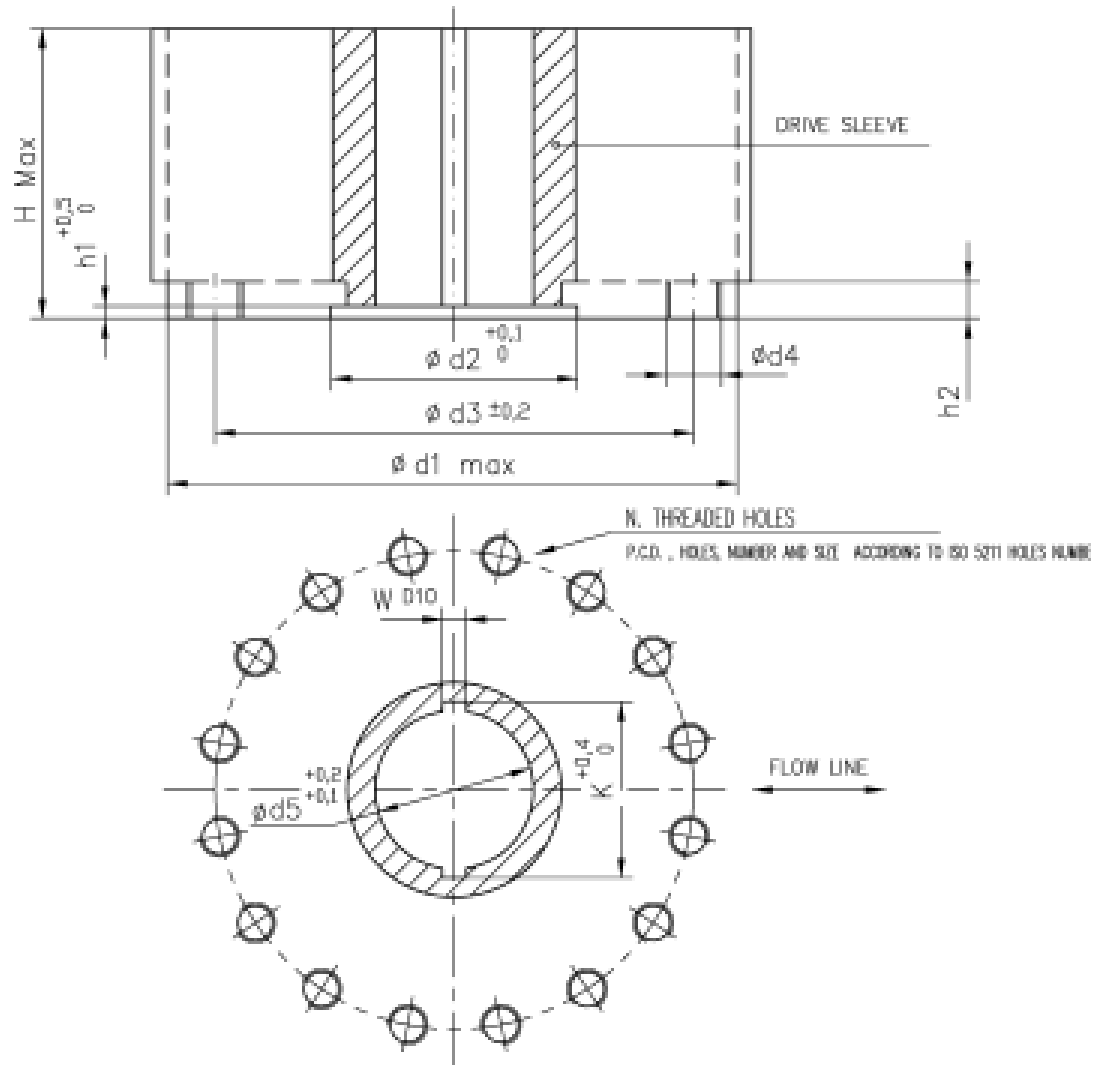

TOP VIEW OF THE SCOTCH YOKE MECHANISM
 (ACTUATOR SHOWN IN CLOSED POSITION)

– MODELS 18,32,35,42–

DIMENSIONS ARE IN MILLIMETERS

ACTUATOR MODEL	$\phi d1$	$\phi d2$	$\phi d3$	$\phi d4$	N	h1	h2	H max	$\phi d5$	W	K
18	680	290	603	M36	16	12	32	350	200	45	220.8
32	780	310	603	M36	16	12	32	400	220	50	242.8
35	780	315	603	M36	16	12	32	400	240	56	264.8
42	840	310	603	M36	16	12	32	400	220	50	242.8

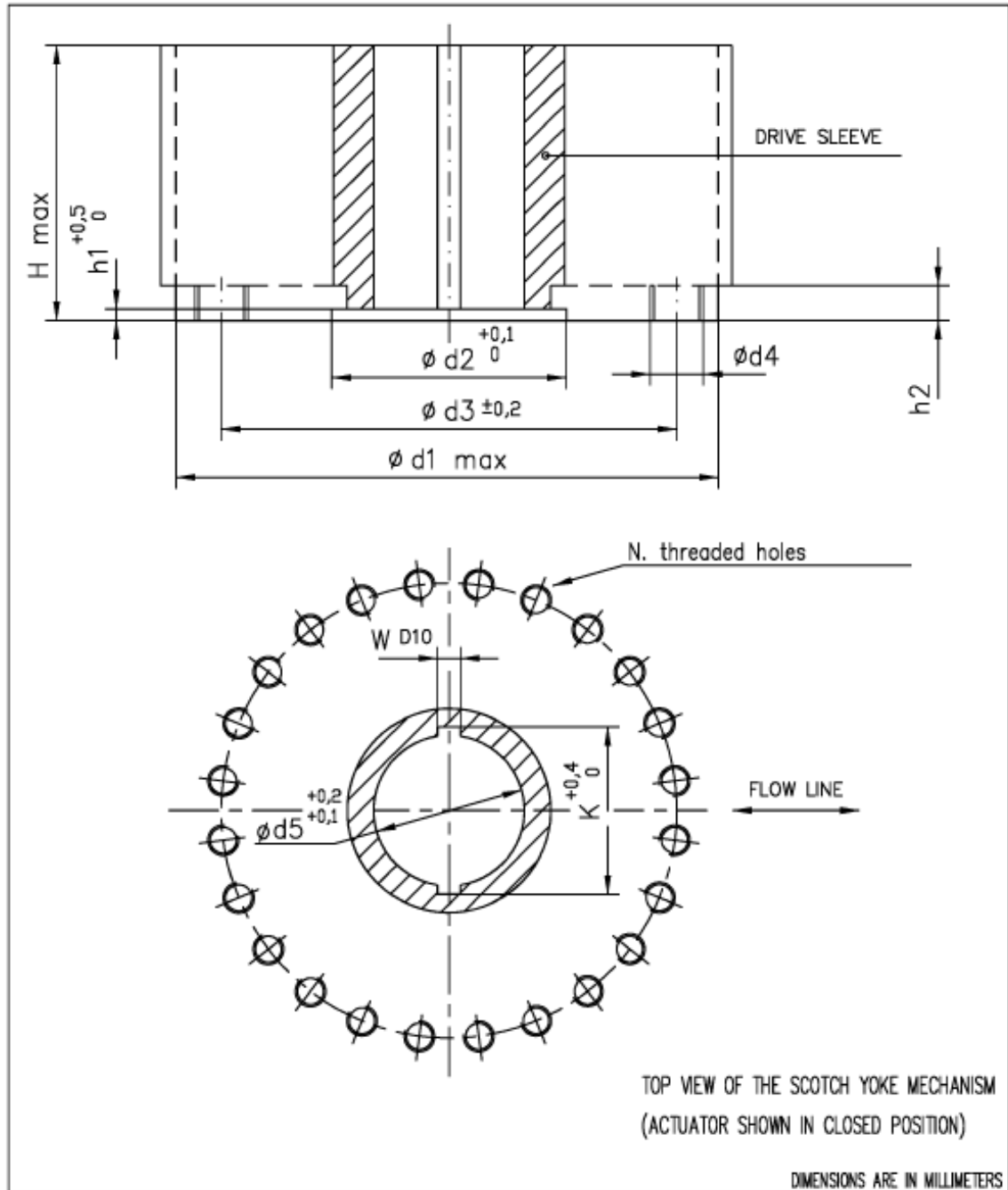

DIMENSIONS ARE IN MILLIMETERS

ACTUATOR MODEL	$\phi d1$	$\phi d2$	$\phi d3$	$\phi d4$	N	h1	h2	H max	$\phi d5$	W	K
50	800	315	698	M36	24	10	32	430	240	56	264.8
60	840	315	698	M36	24	10	32	430	240	56	264.8

B	15/10/19	R.Riso	Orefici	Notes threaded holes revision							
A	06/12/00	F.Callegari	A.Alliani	ADDED COUPLING DIMENSIONS FOR MODEL 60							
Mod.	Data	Eseguita	Approvata	Descrizione Modifica							
 BIFFI ATTUATORI E SISTEMI DI CONTROLLO VALVE ACTUATORS AND CONTROL SYSTEMS		COUPLING DIMENSIONS FOR SCOTCH YOKE STANDARD ACTUATORS - MODEL 50,60 -						Disegno Numero SCN 6201-1			
		Scala //		Data 25/11/92		Disegnato VR		Approvato ZG			

Del presente disegno e' valida solamente la copia con ultima modifica

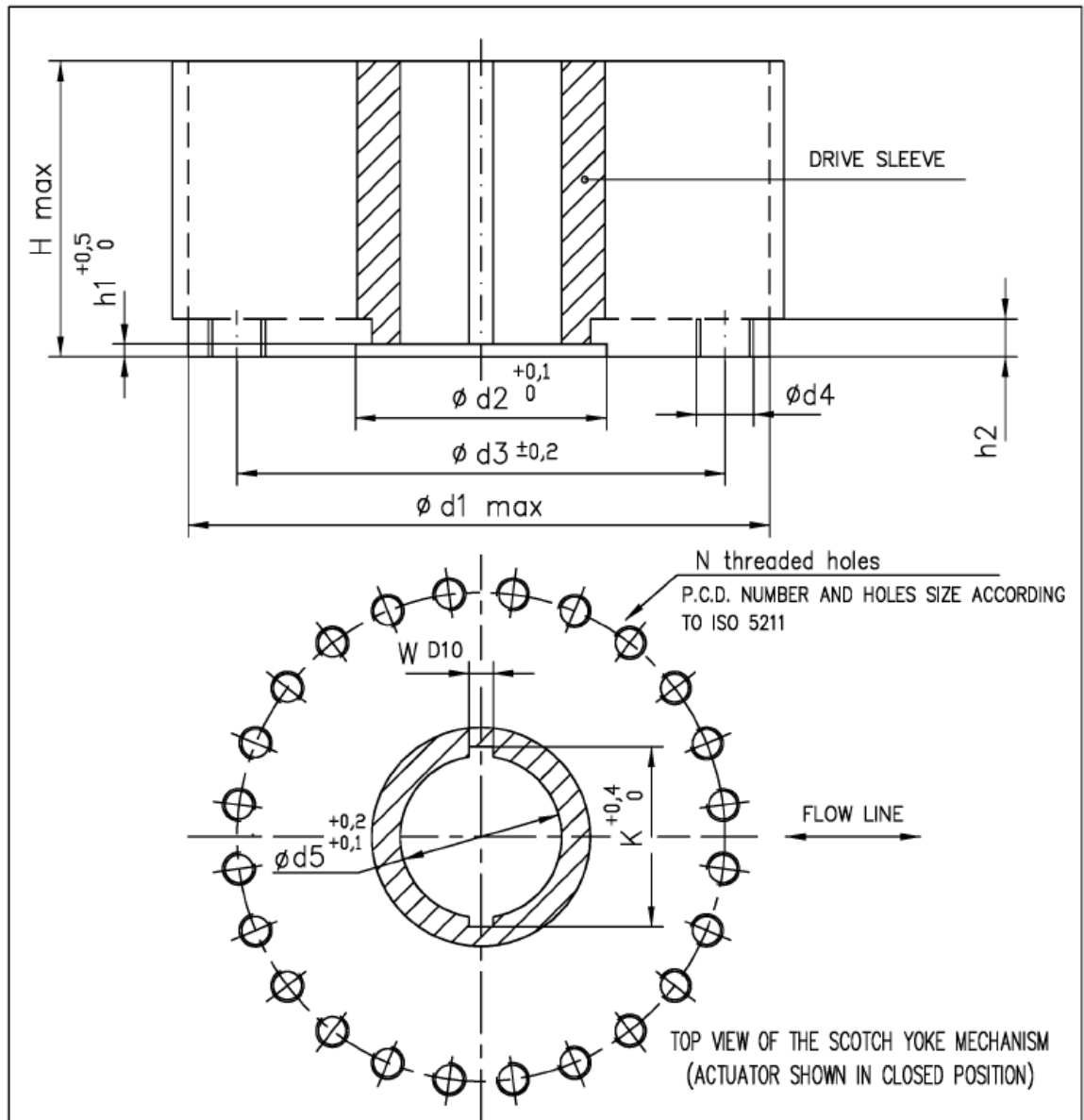

DIMENSIONS ARE IN MILLIMETERS

ACTUATOR MODEL	$\phi d1$	$\phi d2$	$\phi d3$	$\phi d4$	N	h1	h2	H max	$\phi d5$	W	K
65	910	370	813	M42	24	12	37	540	280	46	327,4
80	900	370	813	M42	24	12	37	540	280	46	327,4

Rev.	Date	Drawn	Approved	Description
3	15/10/2019	RISO	OREFICI	Notes threaded holes revision
2	29/12/2016	LOSCHI	OREFICI	Splitted row 80-100
1	13/07/98	CALLEGARI	ALIANI	Added model 80 – Revised dimension "H" (ex 560)

 BIFFI ATTUATORI E SISTEMI DI CONTROLLO VALVE ACTUATORS AND CONTROL SYSTEMS	COUPLING DIMENSIONS FOR SCOTCH YOKE STANDARD ACTUATORS - MODEL 80 -		Drawing Number SCN 6201-3	
	Scala	/	Data	10/03/98
	Disegnato	CALLEGARI	Approvato	ALIANI

Del presente disegno e' valida solamente la copia con ultima modifica

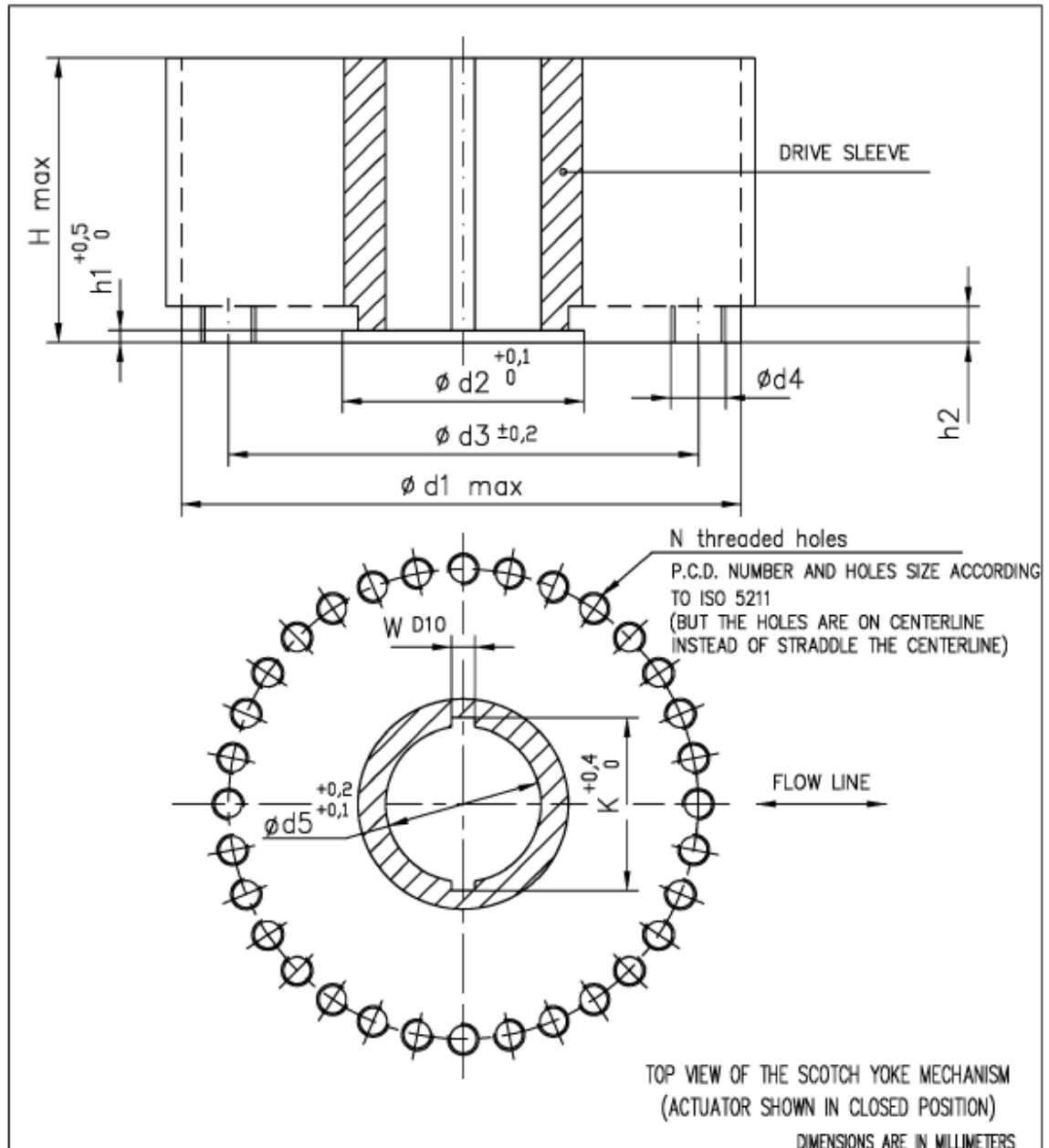

ACTUATOR MODEL	$\phi d1$	$\phi d2$	$\phi d3$	$\phi d4$	N	h1	h2	H max	$\phi d5$	W	K
100	1200	450	1042	M42	32	8	57	600	300	70	328,8
3					Notes threaded holes revision						
2											
1											
Rev.	Date	Drawn	Approved	Description							
 BIFFI <small>ATTUATORI E SISTEMI DI CONTROLLO VALVE ACTUATORS AND CONTROL SYSTEMS</small>		COUPLING DIMENSIONS FOR SCOTCH YOKE STANDARD ACTUATORS - MODEL 100 -						Drawing Number SCN 6201-5			
					Scala /		Data 15/10/19				
					Disegnato Riso		Approvato Orefici				

Del presente disegno e' valida solamente la copia con ultima modifica

If required, for the standard models size 0.3 to 6, Biffi can supply an insert bush with un-machined bore in accordance with Biffi standard table SCN6202. On request the insert bush bore can be machined by

Biffi to couple the valve stem, provided its dimensions match the maximum stem acceptance of the bush according to Biffi doc.: TN1005. The particular execution of the flange and bushing allow the actuator to be rotated by 90° in 4 different positions according to the following figure:

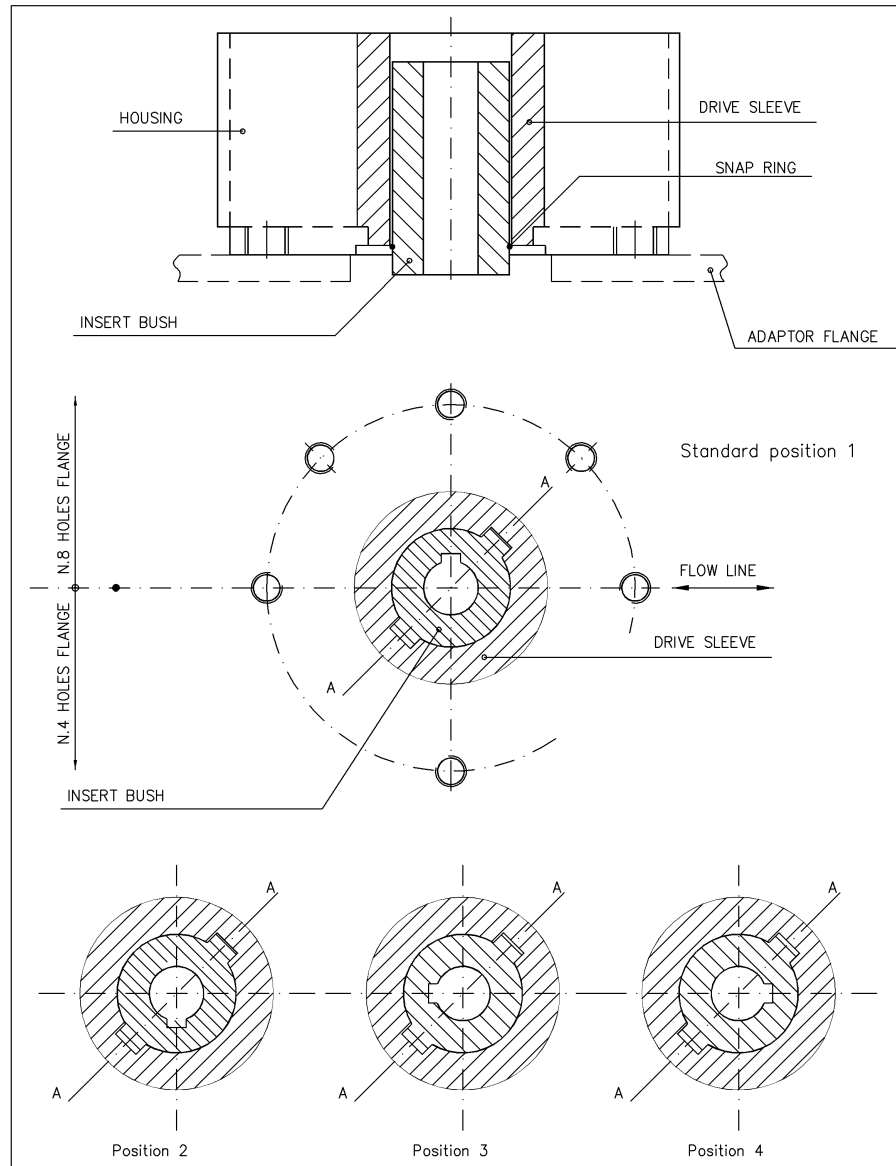

Position 2	Position 3	Position 4
Rotate insert-bush 180° around vertical-standard position (1)	Rotate insert-bush 180° around axis A-A, from position 2	Rotate insert-bush 180° around axis A-A from position 1
<i>Insert bush turned upside down</i>		

Picture 4 – Insert bush + intermediate coupling flange

The Biffi insert bush with 2 external keys at 45° allows to position the keyway for the valve every 90°. Consequently actuator can be

mounted in 4 positions at 90° on top of the valve. For biggest actuator models, the bore of the yoke can be machined according to the dimensions of valve stem.

2.4.2 Assembly procedure



Failure to comply with the following procedures may impair product warranty.



Installation, commissioning and maintenance and repair works should be carried out by qualified staff. A non-conforming assembly could be the source of serious accidents.

For actuator assembly on the valve:



Check that the assembly position, as shown on the documentation, complies with system's geometry. Check the consistency of the parts of actuator-valve coupling.

- Operate the actuator so that it reaches the position matching valve position (Section 3.3).
- Lubricate valve stem with oil or grease.
- Properly clean and remove grease from coupling flange surfaces.
- Connect, if supplied separately, the adjustment insert to valve stem and fasten it with the special fastening pins.
- Lift the actuator using the special lifting points (Sect. 2.2).
- Install the actuator so that valve stem inserts in the coupling area. This coupling should be made without forcing.
- Fasten the two parts with the threaded connections (screws, tie rods, nuts). If holes of coupling flanges are not aligned, adequately operate the actuator if necessary move the mechanical stops backwards (Sect. 3.4).
- Fasten threaded connections. Please refer to Table 1.

Table 1: **nuts tightening torque**

Threading	Tightening torque (Nm)
M8	20
M10	40
M12	70
M14	110
M16	160
M20	320
M22	420
M24	550

M27	800
M30	1100
M33	1400
M36	1700

The screwing values in Table 1 were calculated considering the materials ASTM A320 L7 for screws or tie rods and ASTM A194 gr.2H for the nuts.



2.5 PNEUMATIC CONNECTIONS

Check that the values of pneumatic supply available are compatible with those reported on the identification plate of the actuator.

The connections should be made by qualified staff. Use pipes and connections appropriate as for type, material and dimensions.

- ❑ Properly de-burr the ends of rigid pipes
- ❑ Properly clean the interior of pipes sending through them plenty of the supply fluid used in the system.
- ❑ Mould and fasten the connection pipes so that no irregular strains at entries or loosening of threaded connections occur.
- ❑ Make the connections according to the operating diagram.
- ❑ Check the absence of leakages from pneumatic connections.



2.6 ELECTRICAL CONNECTIONS (IF ANY)

Use components appropriate as for type, material and dimensions

**The connections should be made by qualified staff
Before carrying out any operation, cut line power off**

Safety provisions :

2006/95/EC: Directive for low voltage equipment (until 19 April 2016) 2014/35/EU from 20 April 2016

2004/108/EC: Directive for the electromagnetic compatibility (until 19 April 2016) 2014/30/EU from 20 April 2016

94/9/CE: Directive and safety instructions for use in hazardous Area (until 19 April 2016) 2014/34/EU from 20 April 2016

Remove plastic plugs from cables entries

- ❑ Screw firmly the cable glands.
- ❑ Introduce connection cables.
- ❑ Make the connections in compliance with applicable wiring diagrams on the documentation supplied.
- ❑ Screw the cable gland.

- Replace the plastic plugs of unused entries with metal plugs.

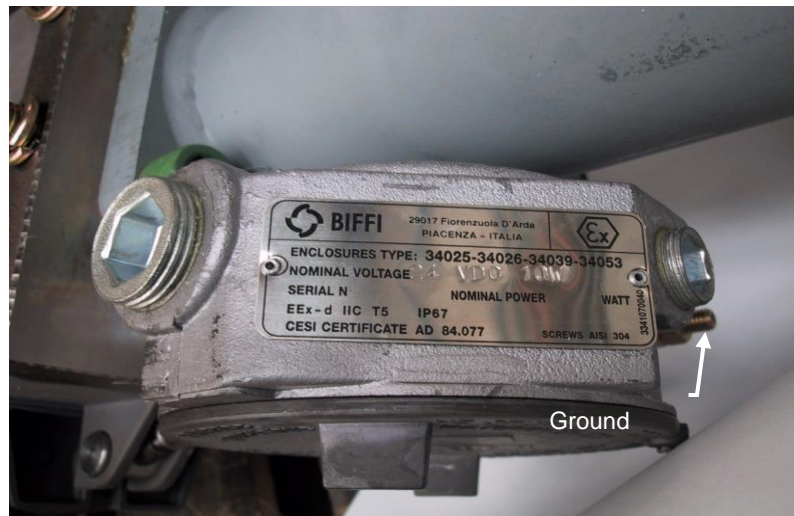
Picture 5 – Junction box on Control group (if foreseen)

2.7 COMMISSIONING



Check that values of electrical supply to the control group (if foreseen) are compatible with those on the plate on the junction box (Picture 5).

Installation, commissioning and maintenance and repair works should be made by qualified staff.

Upon actuator commissioning please carry out the following checks:

- ❑ Check that paint is not be damaged during transport, if necessary repair the damages to paint coat.
- ❑ Check that the pressure and quality of the gas supply (filtering degree, dehydration) are as prescribed. Check that the feed voltage values of the electric components (solenoid valve coils, micro-switches, pressure switches, etc.) are compatible with those reported on the identification plate of the actuator (picture 1).
- ❑ Check that the setting of the components of the actuator control unit (pressure regulator, pressure switches, flow control valves, etc.) meet the plant requirements.
- ❑ Carry out all kinds of operations and check their proper execution (Sect. 3.3).
- ❑ Check the absence of leakages in the pneumatic connections.
If necessary tighten the nuts of the pipe-fittings
- ❑ Check proper operation of all the due signalling (valve position, gas supply pressure etc.)
- ❑ Make a complete functional test in order to verify all the operations are executed according to operating schematic diagram supplied.

3 Operation and use

3.1 OPERATION DESCRIPTION

In the normal operating situation, the ALGA actuator is fed by pressurised gas which flows into the relevant cylinder chamber (for example opening). The cylinder piston stroke causes the actuator operation and the consequent valve movement to the operational position requested (in this case to the “open” position).

Upon a demand, the closing chamber the cylinder is fed by pressurised gas and at the same time the gas is discharged from the open chamber into the return line: the actuator performs the closing operation driven by the piston movement, and the valve moves from the open position to the close (safety-related) position.

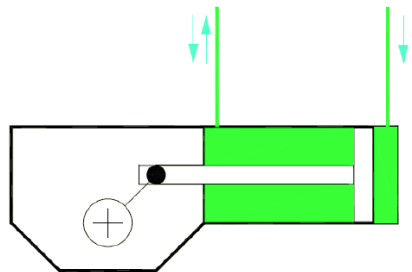

PNEUMATIC CONNECTION

Item	Name
1	Housing
2	Yoke
3	Yoke bushing
4	Cover
5	Guide block pin
6	Sliding block
7	Guide block
8	Guide bar
9	Guide block bushing
10	Travel stop screw
11	Cylinder head flange
12	Piston rod bushing
13	Piston rod seal ring
14	Piston rod
15	Piston
16	Piston guide sliding ring
17	Piston seal ring
18	Cylinder tube
19	End flange
20	Travel stop screw
21	Sealing washer
22	Tie rod

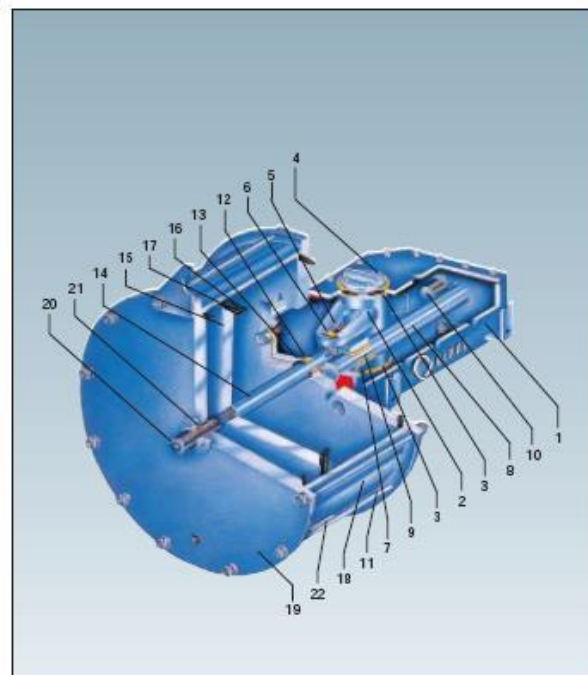

For local or remote operations, please refer for information only to par. 3.3.1 , 3.3.2 , 3.3.3 and 3.3.4 and prior to technical documentation furnished with actuators.

Typical schematics for various applications are follow attached for information only, the function described are furnished only on specific

customer demand. For all the relevant information please refer to the specific technical documentation supplied with actuators.

ON-OFF service: four way control valve

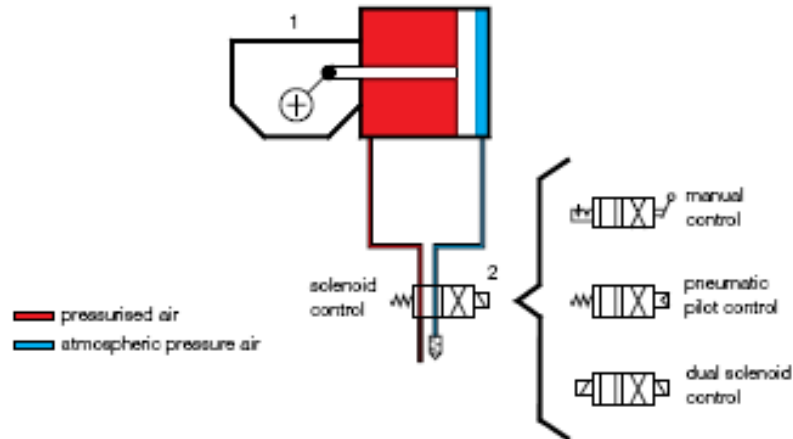

The diagram shows the simplest On-Off control. The gas supply pressure is applied to one side of the cylinder and exhausted from the opposite side. When the control valve (2) is actuated the connection of supply and exhaust to the cylinder chambers are reversed. The control valve can have many types of actuating devices (solenoid, manual control, pneumatic pilot, spring, etc.). The spring return control valves allow “fail safe” operation.

ON-OFF service: air fail safe system

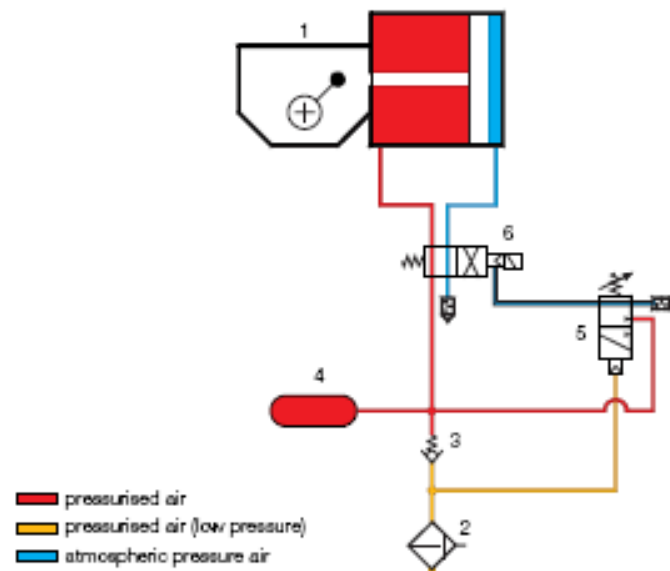

The system allows “fail safe” operation when the pressure in the gas supply line drops below a set value. The diagram shows the actuator in the “fail safe” condition. When the gas supply pressure drops below the pressure switch (5) set point, the pneumatic supply to the solenoid valve (6) pilot is exhausted and the actuator moves to the “fail safe” position by using the gas stored in the tank (4). The tank is connected to the gas supply through the check valve (3).

MODULATING SERVICE :

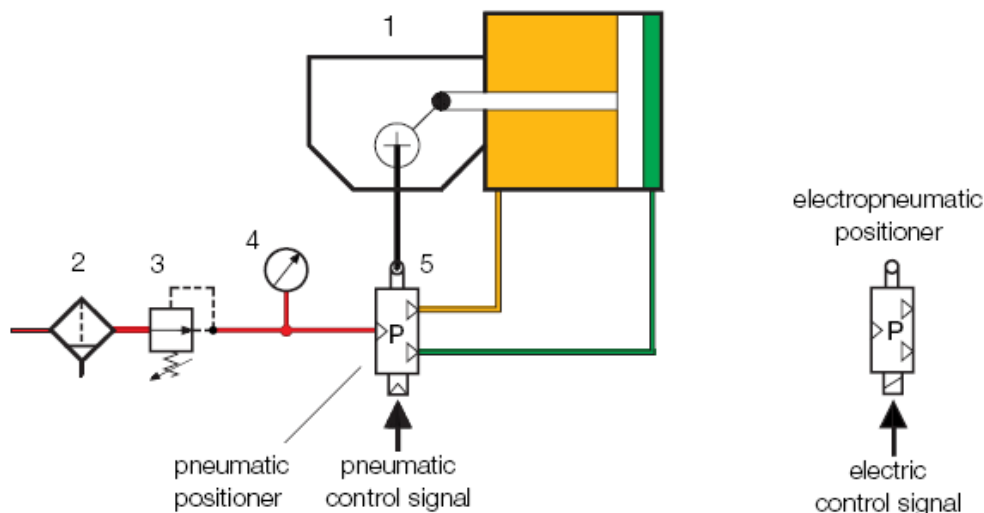

- █ pressurised air (supply)
- █ reduced pressure air (opening chamber)
- █ reduced pressure air (closing chamber)

When modulating control is required as a function of a pneumatic or electric control signal, a positioner (5) is used, which controls the supply to the actuator cylinder to keep the valve in the required angular position. The positioner has a mechanical linkage to the actuator, for a feedback of the valve position.

EMERGENCY MANUAL OVERRIDE

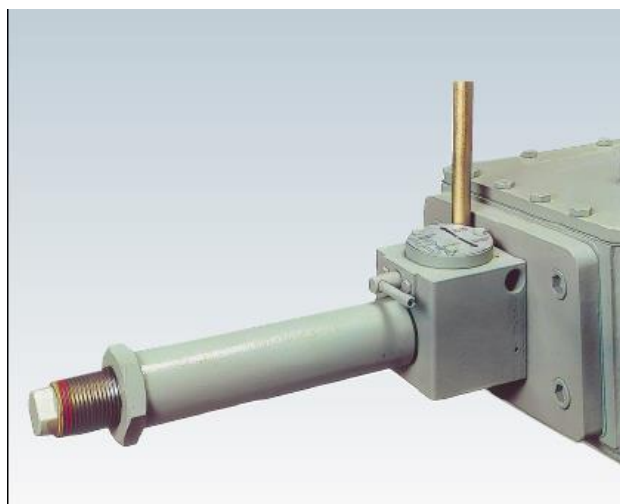

The MHW - MSJ jackscrew manual override can be supplied for model up to 3. The override is mounted on the left side of the actuator, the jackscrew end is screwed into the guide block. A bronze split screw nut is mounted inside the body. By rotating the engagement lever, the screw nut is engaged with the jackscrew. When the screw nut is engaged with the jackscrew manual operation follows by rotating the body of the screw container by a lever (for MSJ models) or by a hand-wheel (for MHW models)

MHP HYDRAULIC MANUAL OVERRIDE

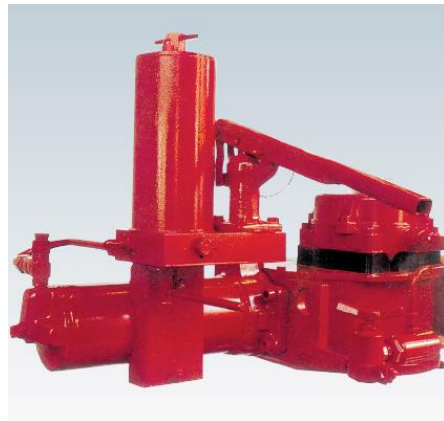

The MHP hydraulic manual override is used to manually operate the actuator in lack of air supply. It also allows to accurately adjust the actuator operating times, independently in opening and in closing, by way of the hydraulic regulators which work on the oil flow from one chamber to the other of the hydraulic cylinder during pneumatic operation. Moreover it permits a smooth angular speed all along the stroke. During manual operation the flow regulators are by-

passed to make the force on the hand pump lever easy. The MHP unit consists of a hydraulic cylinder mounted directly on the actuator. The piston rod end is screwed into the guide block. The compact hydraulic control unit consists of a hand pump, directional control valve, oil tank, relief valve and two unidirectional flow regulators. The directional control valve has three operating positions: “remote”: the actuator is operated by pneumatic supply; “to open”: the actuator operation is opening by hand pump. On request the hydraulic manual override type MHP2 (double hand pump version) can be supplied, which allows the remote control to automatically override manual operation.

Pneumatic operation

The diagram is drawn with actuator under pneumatic operation in opening. The flow regulator Fa allows control of the stroke time

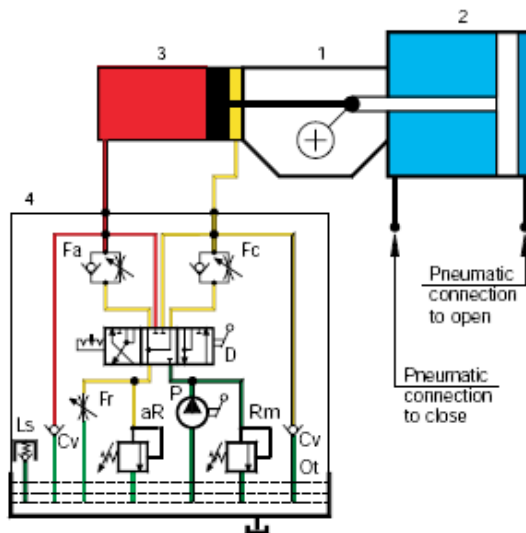

Manual operation

The diagram is drawn with actuator under manual operation towards open. The operation to be performed is selected by the directional control valve D

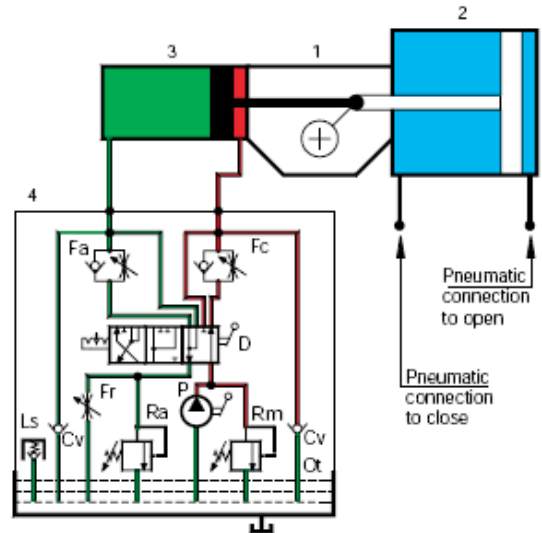

- 1 - Scotch yoke mechanism
- 2 - Pneumatic cylinder
- 3 - Hydraulic cylinder
- 4 - Hydraulic manual override
- High pressure oil
- Intermediate pressure oil
- Low pressure oil
- Pressurised air
- Atmospheric pressure air

- Ra - Relief valve for automatic operation
- Rm - Relief valve for manual operation
- P - Hand pump
- D - Hand operated directional control valve
- Fa - Unidirectional flow regulator (opening operation)

- Fc - Unidirectional flow regulator (closing operation)
- Fr - Bidirectional flow regulator
- Cv - Check valve
- Ot - Oil tank
- Ls - Level stick with relief valve

3.2 RESIDUAL RISKS



**It is recommended to pipe exhaust gas.
The actuator has parts under pressure.
Use the due caution. Use individual protections provided for by
the laws and provisions in force.**

3.3 CALIBRATION OF THE ANGULAR STROKE

The angular stroke of the yoke can be adjusted between $82^{\circ} \div 98^{\circ}$ ($\pm 4^{\circ}$ with respect to the nominal positions of complete opening and closing) by means the mechanical stops screwed into the left side of the housing (open valve) and into the end flange of the pneumatic cylinder (closing) (Picture 7).

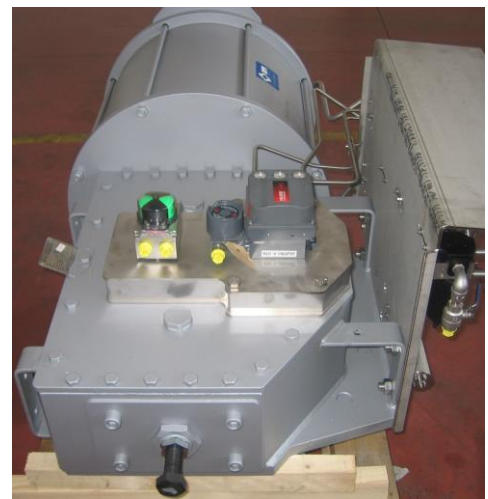

Picture 7 – Mechanical stops

In case of an actuator with two cylinders (Picture 8), both mechanical stops are screwed on the end flanges of the cylinders.



Picture 8 – Actuator with two cylinders

For the adjustment of the travel stop screws proceed as follows :
(see figures "A")

- 1) Loosen the lock nut (2) with a proper wrench (c2).
- 2) If the actuator angular stroke is stopped before reaching the end position (fully open or closed), unscrew the stop screw (1) by turning it anticlockwise with a proper wrench (c1), until the valve reaches the right position. When unscrewing the stop screw, keep the lock nut still with a wrench so that the sealing washer (3) does not withdraw together with the screw.

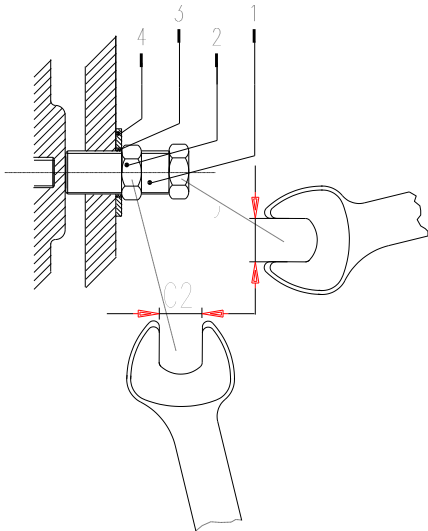

- 3) If the actuator angular stroke is stopped beyond the end position (fully open or closed valve), screw the stop screw by turning it clockwise until the valve reaches the right position.

- 4) Tighten the lock nut (2)

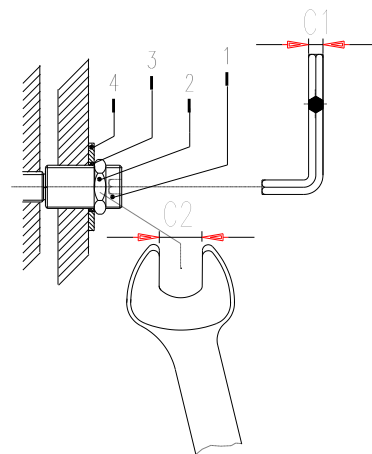

PNEUMATIC CYLINDER SIZE	WRENCH C1 (mm)	WRENCH C2 (mm)
85	30	41
100	30	41
135	30	30
175	30	30
235	30	30

PNEUMATIC CYLINDER SIZE	WRENCH C1 (mm)	WRENCH C2 (mm)
280	17	55
335	17	55
385	17	55
435	17	55
485	17	55
535	17	55
585	17	55
635	17	55
735	17	55
785	17	55
835	17	55
885	17	55
935	17	55
1000	17	55
1100	17	55
1200	17	55
1300	17	80
1450	17	80

For the adjustment of the mechanical stop screwed into the left side of housing, follow these steps (Figure 7 and 9):

- Loosen the locknut (d) with the specific wrench (c2).
- Adjust the pin (g)/screw (v) with the adequate wrench (c1).
- Turn counter-clockwise to increase the angular stroke, turn clockwise to decrease it.
- When the adjustment is over tighten the locknut (d).

ACTUATOR MODEL	WRENCH C1 (mm)	WRENCH C2 (mm)
0,3	30	30
0,9	30	30
1,5	41	41
3	41	41
6	46	46

ACTUATOR MODEL	WRENCH C1 (mm)	WRENCH C2 (mm)
14	17	60
18	17	60
32	17	60
50	17	60

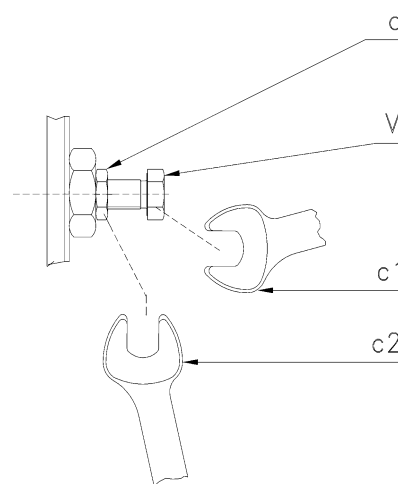

Picture 9 - Mechanical stop on the housing

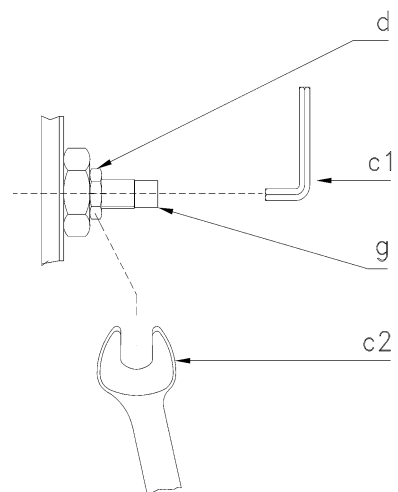

Picture 10 - Mechanical stop on the housing

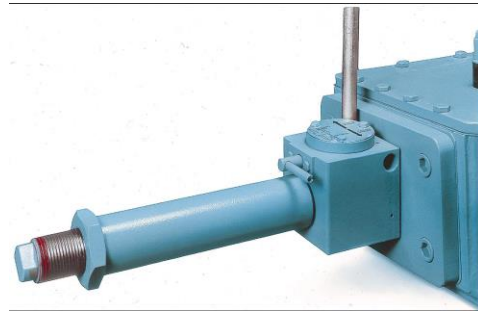

(optional – if foreseen)

For the adjustment of the mechanical stop screwed on the end flange of manual override (see chapt.7.2 table 6: sectional drawing for manual jack-screw MSJ – MHW)

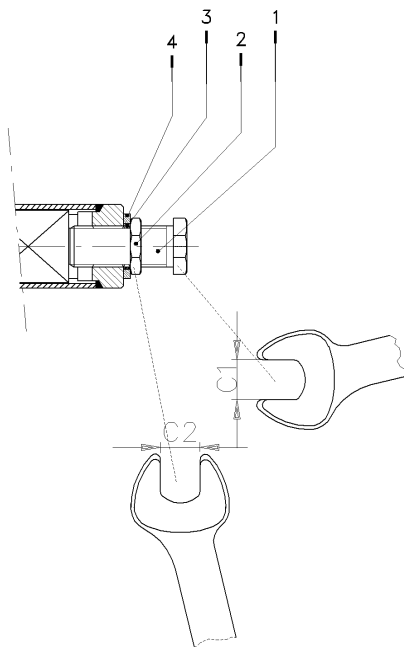

GIG ACTUATOR SIZE	WRENCH C1 (mm)	WRENCH C2 (mm)
0,3	34	34
0,9	34	34

Picture 11 - Mechanical stop on the end flange of manual override

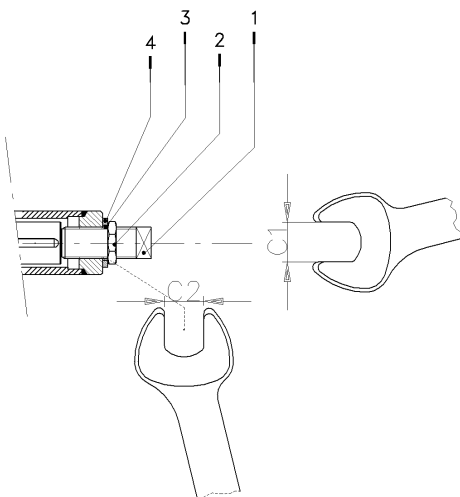

GIG ACTUATOR SIZE	WRENCH C1 (mm)	WRENCH C2 (mm)
1,5	24	65
3	24	65



(optional – if foreseen) For the adjustment of the mechanical stop on the end flange of hydraulic cylinder of MHP, follow these steps (Picture 12):

- ❑ Remove with the specific wrench (c1) the plug (t).
- ❑ Insert a wrench for Allen keys (c2) in the through hole until reaching the adjustment pin (g).
- ❑ Keep the protection cover blocked with the special wrench (c3).
- ❑ Turn counter-clockwise to increase the angular stroke, turn clockwise to decrease it.
- ❑ When the adjustment is over tighten the plug (t).

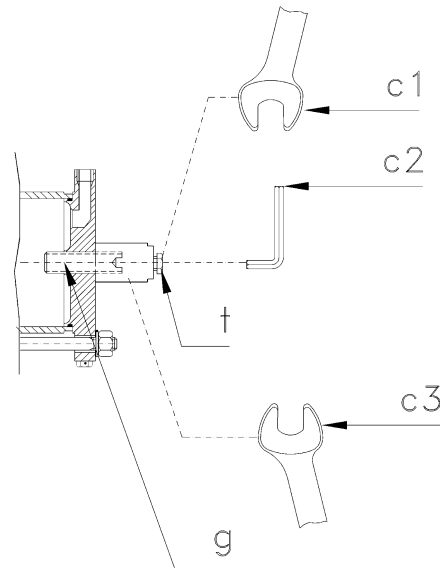

Picture 12 – Mechanical stop of the MHP cylinder

HYDRAULIC CYLINDER SIZE	WRENCH C1 (mm)	WRENCH C2 (mm)	WRENCH C3 (mm)
075	22	10	36
100	22	10	36
135	22	10	36
175	22	14	46
200	27	14	46
235	27	17	65
280	27	17	65
300	36	17	110

3.4 CALIBRATION OF MICROSWITCHES (IF FORESEEN)

(Refer to Safety Instructions Manual for limit switch box)



REFER ONLY TO TECHNICAL DOCUMENTATION RELATED TO INSTALLED SWITCH-BOX MODEL



Operate only the micro-switch corresponding to the direction of operation being carried out, as clearly reported on the micro-switch.

End of stroke microswitches should be operated before the stop of the stroke of the actuator due to mechanical stops. Adjust the relative cams properly.

3.5 CALIBRATION OF THE OPERATION TIME (optional-if foreseen)

The calibration of the operation time is made by Biffi Italia S.r.L according to customer requirements and to technical data-sheet included in technical documentation. If necessary it's possible to modify or reset the operating time through two flow regulation valves placed between the control valves enclosure and the pneumatic cylinder (Picture 16).

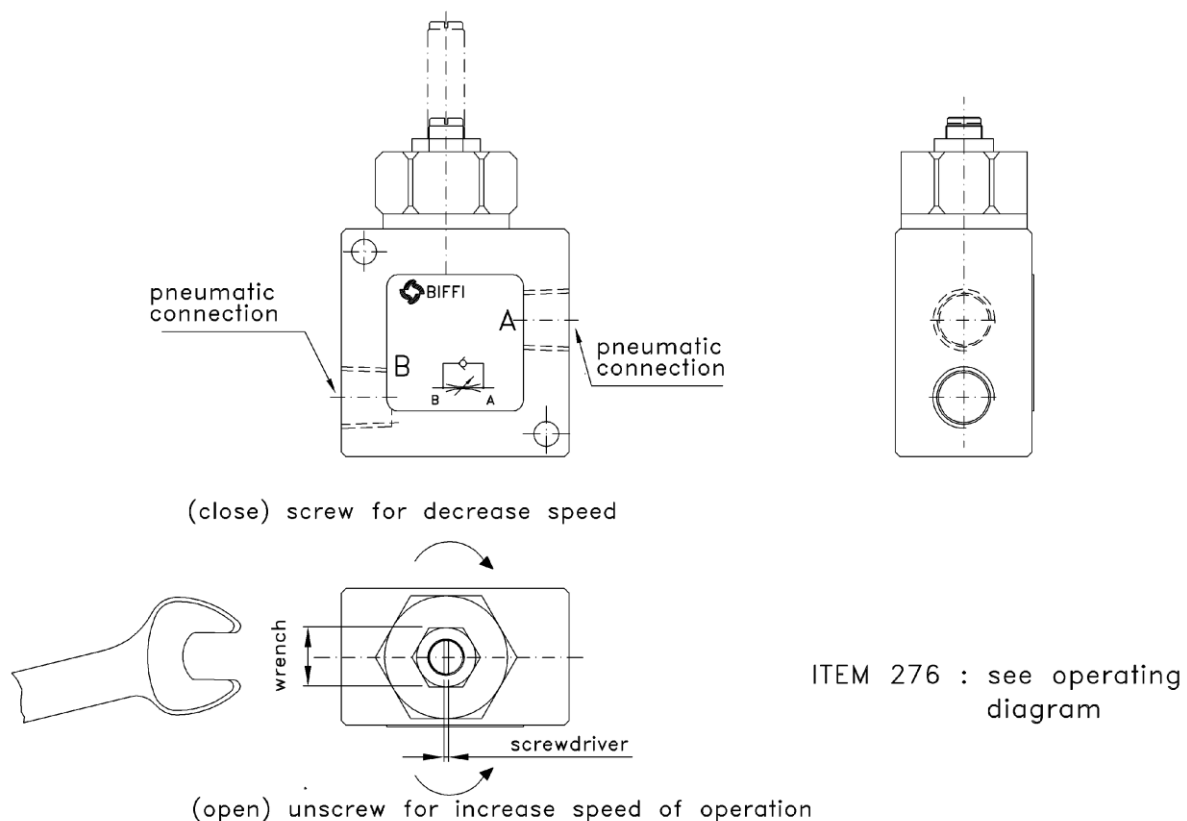

Picture 16 – Example of operating-time adjustment (if foreseen)

To carry out the adjustment, use an adequate Allen wrench and follow these steps (Picture 16):

- Loosen the locknut.
- Screw with a screwdriver the setting screw to increase the operation time.
- Unscrew with a screwdriver the setting screw to decrease the operation time.
- After the adjustment is over screw the locknut

For ALGA actuator models with Manual Hand Pump, the operating time is adjustable through two regulation valves placed on manual hand

pump body (see chapt.7.2 table 5 :sectional drawing for hydraulic control unit MHP)

To carry out the adjustment, use a suitable Allen wrench and follow these steps (Figure 10):

- Remove the cap nut.
- Loosen the locknut.
- Screw with a screwdriver the setting screw to increase the operation time.
- Unscrew with a screwdriver the setting screw to decrease the operation time.
- After the adjustment is over screw the locknut and put back in place the cap nut.

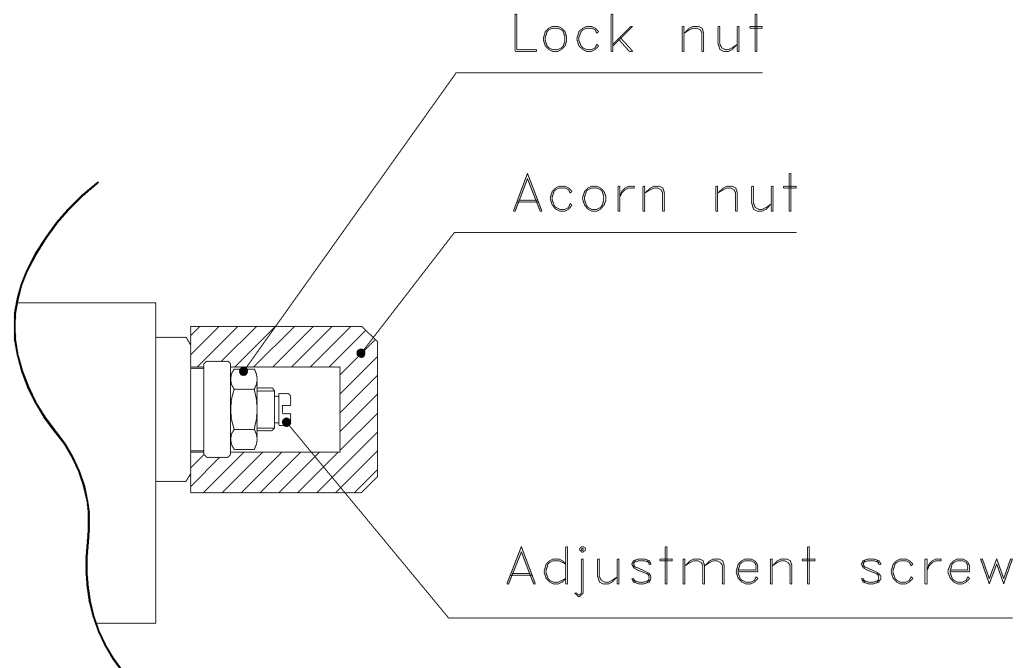

**Picture 17 – Flow regulators placed on Manual Hand Pump
(optional – if foreseen)**

4 Operational tests and inspections

Important: To ensure the guaranteed SIL grade, according to IEC 61508, the functionality of actuator must be checked with regular intervals of time, as described in the Safety Manual



5 Maintenance



Before executing any maintenance operation, it is necessary to close the pneumatic supply line and discharge pressure from the cylinder of the actuator and from the control unit (if foreseen).



Installation, commissioning and maintenance and repair works should be carried out by qualified staff.

5.1 PERIODIC MAINTENANCE

ALGA actuators are designed to operate long-term in heavy-duty operating conditions, without maintenance needs.

Periodicity and regularity of inspections is particularly influenced by specific environmental and working conditions.



They can be initially determined experimentally and then be improved according to actual maintenance conditions and needs.

Anyway every 2 years of operation the following is recommended:

- Check that the actuator operates the valve correctly and with the required operating times. If the actuator operation is very infrequent, carry out a few opening and closing operations with all the existing controls (remote control, local control, emergency controls, etc.), if this is allowed by the conditions of the plant (refer to specific operating diagram, in technical documentation furnished with actuators).
- Check there are no hydraulic or pneumatic leakages.
- Check oil level (Pict. 18) into the hydraulic control unit (see chapt. 5.1.1)
- Check the actuators did not undergo accidental damage with oil leakages found on site (Sect. 4.1.1).
- Check that improper closing of control-group cover did not produce the presence of condensation on it.
- Check the integrity of worn out parts (gaskets, pads etc.).
- Replace, if any, the mechanical filter of the supply gas (refer to chapt. 5.1.2)



Picture 18 – Level measuring stick

**5.1.1 Check and restore oil level in the hydraulic manual override
(refer to chapt. 7.2 table 5)**

Operate the distributor lever to “closing manual operation”.

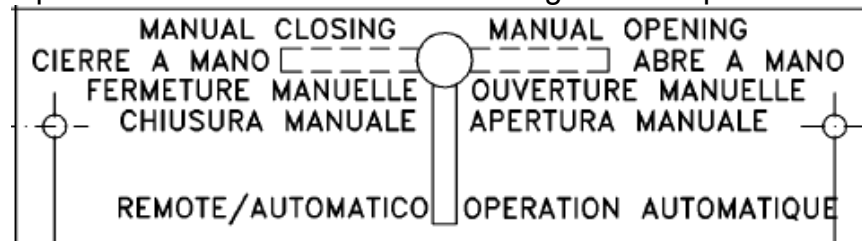

Move the actuator into his “fail to close” position.

Unscrew the dipstick (1).

Check that the oil level into the tank (4) is in correspondance of the “MAX LEVEL” notch of the dipstick.

Screw and tighten the dipstick.

If necessary substitute or added the oil, proceeding as follow:

- ❑ Remove the dipstick (1) from the tank cover (22).
- ❑ Unscrew the plug (27) and the washer (9) to drain all the oil.
- ❑ If some dirt or/and sludge is found in the oil drained from the tank, before filling with new oil in the tank, disassemble the oil tank tube, by unscrewing the two cap nuts (2), and clean the internal surfaces of the tank. If necessary substitute the gaskets (21) of the tank.
- ❑ Replace the plug (27) and the washer (9) into the plate (11) and tighten.
- ❑ Pour the new oil into the tank through the dipstick hole (1) on the cover (22).
- ❑ Replace the dipstick (1).
- ❑ Add oil (refer to Table 2) if in the tank the oil level is BELOW THE MINIMUM (Picture 13: minimum level is in correspondance to the end of dipstick) until to reach the optimal (MAXIMUM) oil level .
- ❑ Operate the distributor lever to “Remote” position



For refill use oil of the same brand as previous, refer to related technical documentation

Table 2: features of hydraulic oil suggested by BIFFI Italia S.r.l for refilling in different working condition:

Standard temperature conditions (-30°C/+85°):

Producer	AGIP
Name	ARNICA 22
Viscosity at 40° C	20.9 mm ² /s
Viscosity at 100° C	4.73 mm ² /s
Viscosity index ASTM	153
Flash point	192° C
Pour point	-42° C
Specific weight (at 15°C)	0,857 Kg/l

Equivalent oils:

SHELL TELLUS PLUS 22
 CHEVRON HYDRAULIC OIL AW ISO 22
 MOBIL DTE22
 EXXON UNIVIS N22
 EQUIVIS ZS22
 BP ENERGOL HLP-HM22
 CASTROL DYSPIIN AWS22

Low temperature conditions (until -46°C):

Manufactured	SHELL
Name	AEROSHELL FLUID 41
Viscosity at -54° C	2300 cST
Viscosity at -40° C	491 cST
Viscosity at 40° C	14,1 cST
Viscosity at 100° C	5,30 cST
Viscosity index (ISO 2909)	>200
Flash point	105° C
Pour point	<-60° C
Specific weight	0,87 Kg/dm³

(or equivalent)

Low temperature conditions (until -60°C):

Manufactured	SYNTHESIS
Name	SYNTRASS-CS 500
Viscosity at -60° C	580 cST
Viscosity at -30° C	39cST
Viscosity at 20° C	5,8 cST
Viscosity at 50° C	2,1 cST
Flash point	152° C
Pour point	-68° C
Specific weight	0,897 Kg/dm³

(or equivalent)

5.1.2 Gas supply dehydrating filter maintenance (if foreseen)

The gas supply filter is fitted with a mechanical filter and a drain valve to discharge periodically the water generated by the condensation of the humidity inside the gas supply.



During the routine maintenance it is recommended to check and clean the mechanical filter and replace it in case of heavy dirty conditions.

To disassemble the filter proceed as follow:

- a) close the stop valve at the inlet of pressure supply line;
- b) discharge the pressure from the drain valve;
- c) Remove the lower enclosure screws,
- d) remove the mechanical filter;
- e) clean or replace the filter;

reinstall all parts carefully paying attention to avoid any damage to the O-ring

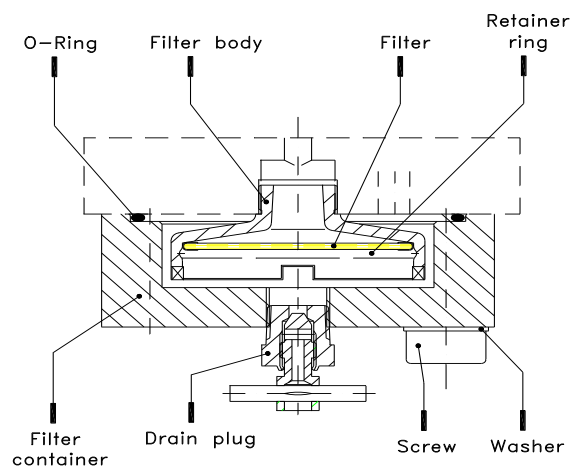

5.2 EXTRAORDINARY MAINTENANCE

If there are leaks in the hydraulic cylinder, pneumatic cylinder or a malfunction in the mechanical components, or in case of scheduled preventive maintenance, the actuator must be dis-assembled and seals must be replaced with reference to the follow general sectional drawing and adopting the following procedures:

5.2.1 Replacement of cylinder seals (refer to figure 1 on follow page)

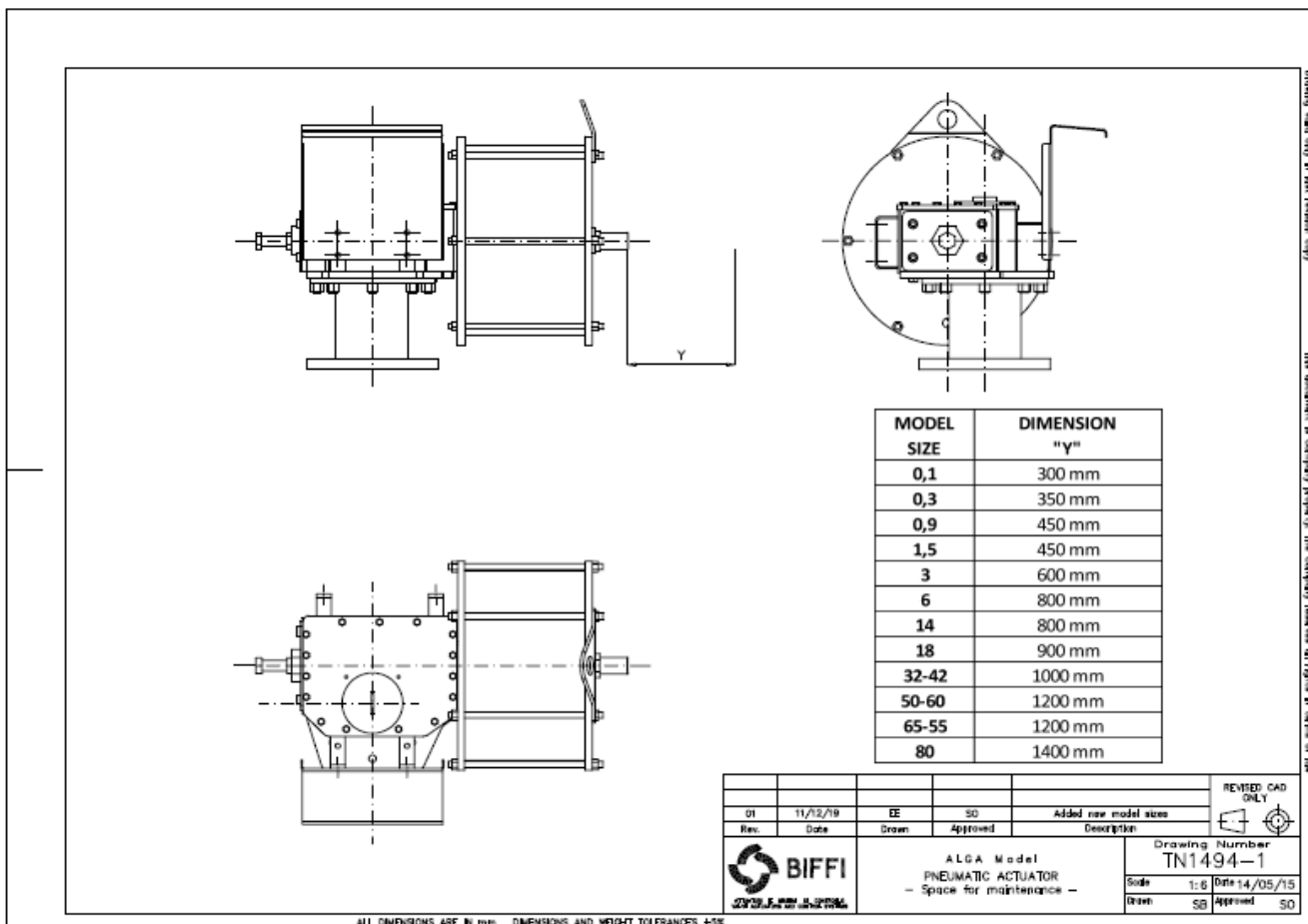

Before executing any maintenance operation, it is necessary to intercept the supply line and discharge pressure from the cylinder of the actuator.

If the actuator can be operated, it is essential to take it to fail safe position, otherwise the actuator should be disassembled from the valve and follow these steps:

- 1) Remove the nuts (16) and the washers (24) from the tie rods (18) at the end flange (22) side.
- 2) Slide off the end flange (22) and the tube (19).
- 3) Remove the screw (2) and the cover (1).
- 4) Unscrew the piston rod (20) threaded end from the adaptor bush (30) of guide block (14).
- 5) Slide off the piston rod (20) from the head flange (17).
- 6) Disassemble the head flange (17) from the mechanism housing (8) by removing the screw (15) only if the gasket (36) has to be replaced because damaged.

Seals replacement

Prior to reassemble check that the actuator components are in good conditions and clean. Lubricate all the surfaces of the parts, which move in contact with other components, by recommended grease (AGIP-ENI HTX-SIL if seals are in NBR/Viton or Neoprene rubber, with Aeroshell Grease 7 if the seals are in Fluorosilicon rubber). If the O-ring must be replaced, remove the existing one from its groove, clean the groove carefully and lubricate it with protective grease film. Assemble the new O-ring into its groove and lubricate it with a protective grease film.

- 1) Replace the O-rings (39-40) of the head flange (17).
- 2) Replace the O-ring (42) and the guide sliding ring (41) of the piston (21). Replace the O-ring (40) of the end flange (22).

If the sealing washer (43) has to be replaced, measure the protrusion of the stop screw (26) with reference to the end flange (22) surface, so as to be able to easily restore the setting of the actuator mechanical stop in the closed valve position, once the maintenance procedures have been completed.

- 1) Loosen the lock nut (25) and unscrew the stop screw (26) until it is removed together with the nut (25), the washer (44) and the sealing washer (43).
- 2) Remove the sealing washer (43) from the stop screw (26). Carefully clean and lubricate the stop screw thread and the surface of the end flange area, on which the sealing washer works.
- 3) Screw the new sealing onto the stop screw until it touches the nut (25).
- 4) Assemble the washer (44) onto the sealing washer (43).
- 5) Screw the stop screw into the threaded hole of the end flange until it reaches its original position (the same protrusion with reference to the flange surface).
- 6) Check that the sealing washer (43) and the washer (44) are in contact with the flange surface.
- 7) Tighten the lock nut (25).

Reassemble:

- 1) Assemble the new gasket (36) after cleaning the surfaces of housing (8) and head flange (17), which are in contact.
- 2) Assemble the head flange (17), replace the washers (37) if damaged, tighten the screws (15) to the recommended torque.
- 3) Lubricate the piston rod (20) surface, with a protective oil film and introduce it into the head flange hole, taking care not to damage the O-ring (39). Carefully clean the threaded end of the piston rod (20) and the threaded hole of the adaptor bush (30) of guide block (14). Spreads some sealant LOCTITE 452, or equivalent, on the rod

- threaded end and screw into the adaptor bush (30) threaded hole and tighten.
- 4) Carefully clean the inside of the tube (19) and check that the entire surface, particularly that of the bevels, is not damaged. Lubricate the inside surface of the tube and the bevels at the ends. Slide the tube onto the piston taking care not to damage the piston O-ring (42) and the head flange O-ring (40).
 - 5) Assemble the end flange by centring it on the inside diameter of the tube, taking care not to damage the O-ring (40).
 - 6) Assemble the washers (24) and the nuts (16) onto the tie rods (18). Tighten the nuts to the recommended torque, alternating between opposite corners.
 - 7) Restore a generous coating of grease on the contact surfaces of the yoke (11) and the bushing (33), on the yoke grooves, on the sliding block (5), on guide bar (9).
 - 8) Assemble the new gasket (10) after cleaning the surfaces of the housing (8) and cover (1)
 - 9) Lubricate with protective oil the O-ring (32).
 - 10) Assemble the cover (1) and the screw (2). Tighten the screws to the recommended torque.
- 11) Carry out a few actuator operations to check that its movement is regular and that there is no air leakage through the seals.



After maintenance operations carry out a few actuator operations (5-10) to check that its movement is regular, that there is no air leakage through the seals and to eliminate any oil residues in the air circuit, deriving from the lubrication of the seals during the replacement phase

FIGURE 1 : ALGA double acting pneumatic actuator

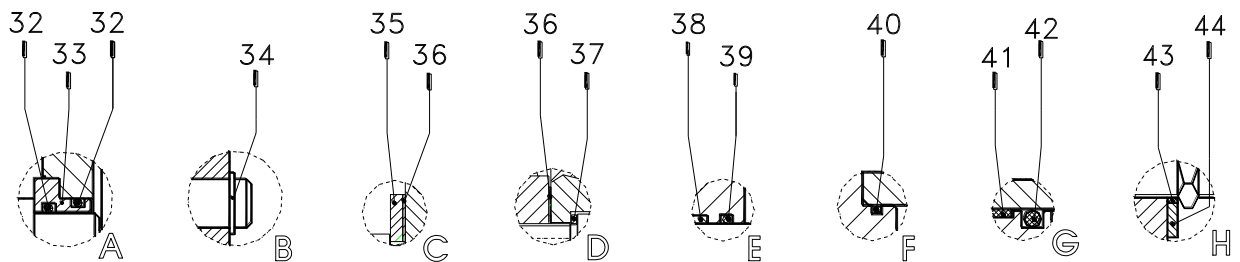
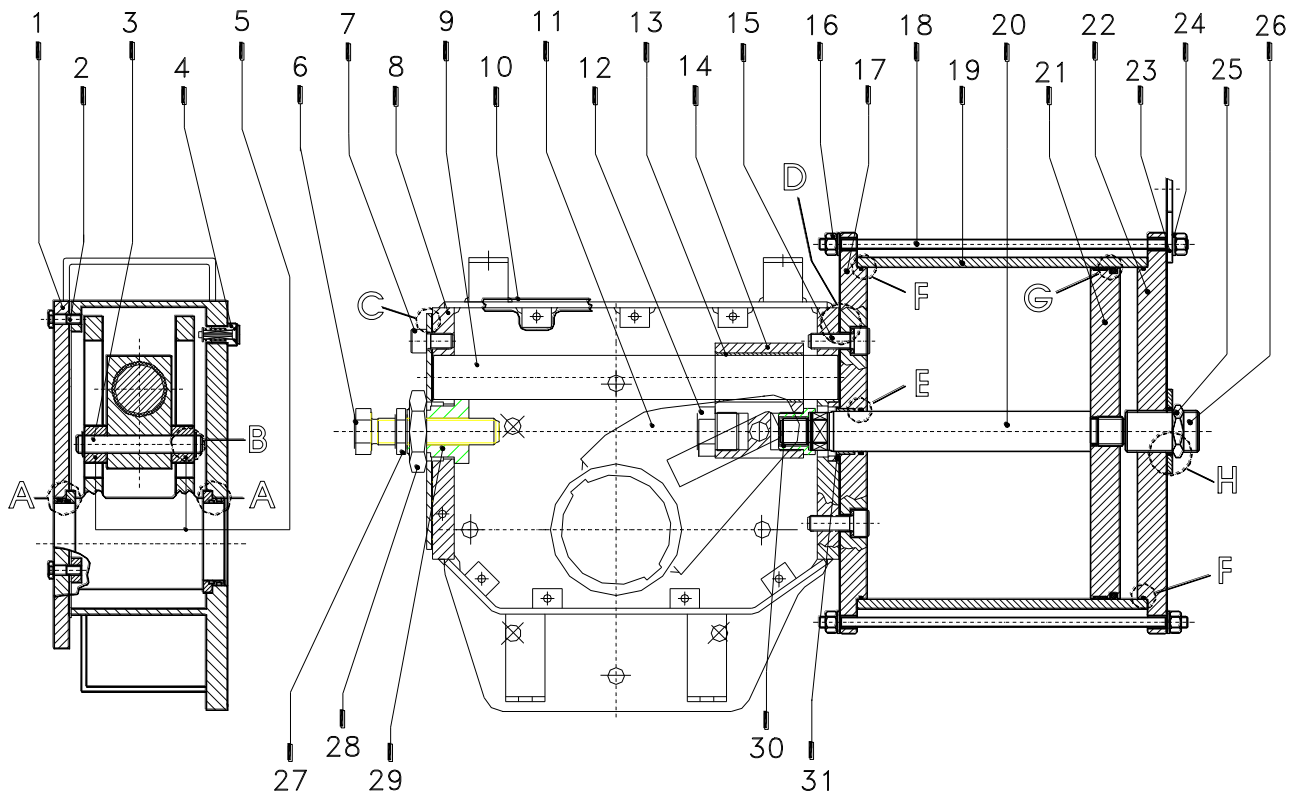

ITEM	DESCRIPTION	ITEM	DESCRIPTION	ITEM	DESCRIPTION
1	Cover	16	Nut	31	Washer
2	Screw	17	Head flange	32	O – ring
3	Guide block pin	18	Tie rod	33	Yoke bushing
4	Vent valve	19	Cylinder tube	34	Retainer ring
5	Sliding block	20	Piston rod	35	Flange
6	Screw	21	Piston	36	Gasket
7	Screw	22	End flange	37	Washer
8	Housing	23	Lifting eyelet	38	Piston rod bushing
9	Guide bar	24	Spring washer	39	O–Ring
10	Cover gasket	25	Nut	40	O–Ring
11	Yoke	26	Stop setting screw	41	Guide sliding ring for piston
12	Plug	27	Nut	42	O–Ring
13	Bushing	28	Nut	43	Sealing washer
14	Guide block	29	Stopper bush	44	Washer
15	Screw	30	Adaptor bush		

b2) Replacement of hydraulic cylinder seals (see Fig.2) only for ALGA-MHP hydraulic hand-pump manual override

If there are leaks in the hydraulic cylinder or a malfunction in the mechanical components, or in case of scheduled preventive maintenance, the actuator must be dis-assembled and seals must be replaced with reference to the sectional drawing and adopting the following procedures:

- 1) Remove the nuts (item 16) and the washers (item 15) from the tie rods (item 10) at the end flange (item 13) side.
- 2) Slide off the end flange and the tube (item 12).
- 3) Remove the screws (item 2-Fig.1) and the cover (item 1 Fig.1).
- 4) Unscrew the piston rod (item 6) threaded end from the adaptor bush (item 30-Fig.1) of guide block (item 14-Fig.1).
- 5) Slide off the piston rod from the head flange (item 2).
- 6) Disassemble the head flange from the mechanism housing (item 8-Fig.1) by removing the screws (item 7-Fig.1) only if the gasket (item 36-Fig.1) has to be replaced because damaged.

Seals replacement

Prior to reassemble check that the actuator components are in good conditions and clean. Lubricate all the surfaces of the parts, which move in contact with other components, by recommended oil (**SHELL OMALA S4 WE or equivalent**). If the O-ring must be replaced, remove the existing one from its groove, clean the groove carefully and lubricate it with protective oil film. Assemble the new O-ring into its groove and lubricate it with a protective oil film.

- 1) Replace the O-rings (3) of the head flange (2).
- 2) Replace the O-ring (3) of the end flange (13).

For replacement of piston rod seal ring (4) and of the O-ring (5) proceed as follows:

- 1) Remove the existing Teflon seal ring (4) and the O-ring (5) from their groove.
- 2) Clean the groove carefully and lubricate it with a protective oil film.
- 3) Assemble the new O-ring into its groove and lubricate it with a protective oil film.
- 4) Assemble the new Teflon seal ring (4) into the flange groove, on the rubber O-ring (5), by bending it: take care that the bending radius is as large as possible to avoid damaged the seal. Then enlarge the seal ring with your fingers so as to restore its round shape: pay attention not to utilise any tools, which can damage the seal ring.

To replace the piston seal ring (9) and the O-ring (19) proceed as follows:

- 1) Remove the existing Teflon seal ring (9) and the O-ring (19) from their groove.
- 2) Clean the groove carefully and lubricate it with a protective oil film.
- 3) Assemble the new O-ring into its groove and lubricate it with a protective oil film.
- 4) Assemble the new Teflon seal ring (9) on its rubber O-ring (19) by introducing one side of it into the groove and then enlarge it with your fingers so as to introduce it into the groove: take care to enlarge it uniformly without any tools which could possibly damage it. The elastic memory of the kind of Teflon type the seal ring is made of allows the ring to shrink back to its previous dimension after a short time.

If the o-ring (17) has to be replaced, measure the protrusion of the stop screw (11) with reference to the end flange (13) surface, so as to be able to easily restore the setting of the actuator mechanical stop in the open valve position, once the maintenance procedures have been completed.

- 5) Loosen the stop setting screw cover (14) and unscrew the stop screw (11).
- 6) Remove the o-ring (17) from the stop screw (11). Carefully clean and lubricate the stop screw thread and the surface of the end flange area, on which the o-ring works.
- 7) Screw the new o-ring onto the stop screw until it touches the cover (14).
- 8) Screw the stop screw into the threaded hole of the end flange until it reaches its original position (the same protrusion with reference to the flange surface).
- 9) Check that the o-ring (17) is inside the groove into the end flange and in contact with the groove bottom surface.

Reassemble

- 1) Assemble the new gasket (item 36-Fig.1) after cleaning the surfaces of housing (item 8-Fig.1) and head flange (item 2) which are in contact.
- 2) Assemble the head flange and tighten the screws (item 7-Fig.1) to the recommended torque.
- 3) Clean and lubricate the piston rod (item 6) surface, particularly that of the bevel, with a protective oil or grease film and introduce it into the head flange hole, taking care not to damage the Teflon seal ring (item 4): the piston rod bevel has to enlarge smoothly the seal ring.

- 4) Carefully clean the threaded end of the piston rod and the threaded hole of the adaptor bush (item 30-Fig.1) of guide block (item 14-Fig.1). Spread some sealant LOCTITE 452, or equivalent, on the rod threaded end and screw into the adaptor bush threaded hole and tighten.

- 5) Carefully clean the inside of the tube (item 12) and check that the entire surface, particularly that of the bevels, is not damaged. Lubricate with protective oil film the tube inside surface and the bevels at the ends. Slide the tube onto the piston taking care not to damaged the Teflon seal ring (item 9): the tube bevel has to smoothly compress the seal ring.

- 6) Take care also not to damage the head flange O-ring (item 3).

- 7) Assemble the end flange (item 13) by centring it on the inside diameter of the tube, taking care not to damage the O-ring (item 3).

- 8) Assemble the washers (item 15) and the nuts (item 16) onto the tie rods (item 10). Tighten the nuts to the recommended torque, alternating between opposite corners.

- 9) Restore a generous coating of grease on the contact surfaces of the yoke (item 11-Fig.1) and the bushings (item 13-Fig.1), on the yoke grooves, on the sliding blocks (item 5-Fig.1), on guide bar (item 9-Fig.1).

- 10) Assemble the new gasket (item 36-Fig.1) after cleaning the surfaces of the housing (item 8-Fig.1) and cover (item 1-Fig.1)

- 11) Lubricate with protective oil the O-ring (item 32-Fig.1).

- 12) Assemble the cover (item 1-Fig.1) and the screws (item 2-Fig.1). Tighten the screws to the recommended torque.



After maintenance operations carry out a few actuator operations (5-10) to check that its movement is regular, that there is no air leakage through the seals and to eliminate any oil residues in the air circuit, deriving from the lubrication of the seals during the replacement phase

5.3 MHP HYDRAULIC MANUAL OVERRIDE MAINTENANCE AND TROUBLE SHOOTING

5.3.1 Operation

(see the attached operating diagram MAN 562-A)

The “Mhp” hydraulic manual override and speed control unit is utilized, in connection with the actuator hydraulic cylinder, for the manual operation and for the speed control during the pneumatic operation of pneumatic double acting actuators.

5.3.2 Manual operation

Selected by the hand operated directional control valve (D) the operation (opening or closing) to be performed.

Actuate the hand pump (P)

The relief valve (Rm) prevents that the oil pressure delivered by the hand pump exceeds the set value so to not damage the valve or the actuator.

5.3.3 Remote operation

To allow the actuator pneumatic operation the hand operated directional control valve (D) has to be in its “REMOTE” control position: valve lever in its central position as shown by the instructions plate.

Pneumatic operation

The oil flows from the hydraulic cylinder chamber, rear flange side, via the flow regulator (Fa), the valve (D) and the flow regulator (FC), free flow direction, to the hydraulic cylinder chamber, head flange side.

The exceeding oil volume, corresponding to the hydraulic cylinder piston rod, flows via the flows regulator (Fr) into the oil tank (Ot).

The relief valve (Ra) prevents that the oil pressure, into the hydraulic cylinder, exceeds a set value.

The flow regulator (Fa) allows the setting of the actuator operation speed in opening independently from the actuator speed in closing.

B2)Pneumatic closing operation

The oil flows from the hydraulic cylinder chamber, head flange side, via the flow regulator (Fc), the valve (D) and the flow regulator (Fa),

free flow direction, to the hydraulic cylinder chamber, rear flange side.

The missing oil volume, corresponding to the piston rod of hydraulic cylinder, is sucked from the oil tank via the check valve (Cv).

The flow regulator (Fc) allows the setting of the actuator operation speed in closing, independently from the actuator speed in opening.

5.3.4 Setting

A) Setting of the actuator operating times (see the attached sectional drawings)

The setting of actuators operating times in opening and in closing is performed by adjusting the unidirectional flow regulators (items Fa and Fc of operating diagram MAN 562-A) assembled into the plate (item 11): into the plate left side the flow regulator for the actuator opening time setting; into the plate right side the flow regulator for the actuator closing time setting.

As the flow regulators are unidirectional type the actuator operating times can be set independently in opening and in closing.

To perform the setting of the flow regulators proceed as follows.

⇒ Unscrew the cap nut (item 2) from the setting screw (item 28).

⇒ Loosen the lock nut (item 30).

⇒ By a screwdriver rotate clockwise the setting screw (item 28) to increase the operating time; rotate counter clockwise to decrease the operating time.

⇒ Check that the operating time is the required one.

⇒ Tighten the lock nut (item 30). During this operation keep the setting screw (item 28) still with a screwdriver.

⇒ Screw the cap nut (item 2) on the setting screw end and tighten so to assure the tightness.

B) Settings of relief valves (see the attached sectional drawings)

The relief valve (item Ra of operating diagram MAN562-A) is set at BIFFI factory at a proper value and there is no reason to change the setting on the field.

The relief valve (item Ra of operating diagram MAN562-A) is set at BIFFI factory at a pressure value at least 20% higher than the pressure required into the hydraulic cylinder, during the manual operation by the hand pump, to overcome the valve required torque, in opening and in closing, along all the valve angular stroke.

At the same time the set value is at least 10% lower than the pressure required into the hydraulic cylinder to perform the maximum allowable torque of the actuator and of the valve.

If a setting of the relief valve has to be performed, proceed as follows:

⇒ Unscrew the cap nut (item 2) from the setting screw (item 44).

⇒ Loosen the lock nut (item 30).

⇒ By a male hexagonal wrench rotate clockwise the setting screw (item 44) to increase the pressure setting value; rotate counterclockwise to decrease the pressure set value.

⇒ Check that the pressure set value is the required one.

⇒ Tighten the lock nut (item 30). During this operation keep the setting screw (item 44) still with an hexagonal male wrench.

⇒ Screw the cap nut (item 2) on the setting screw end and tighten so to assure the tightness.

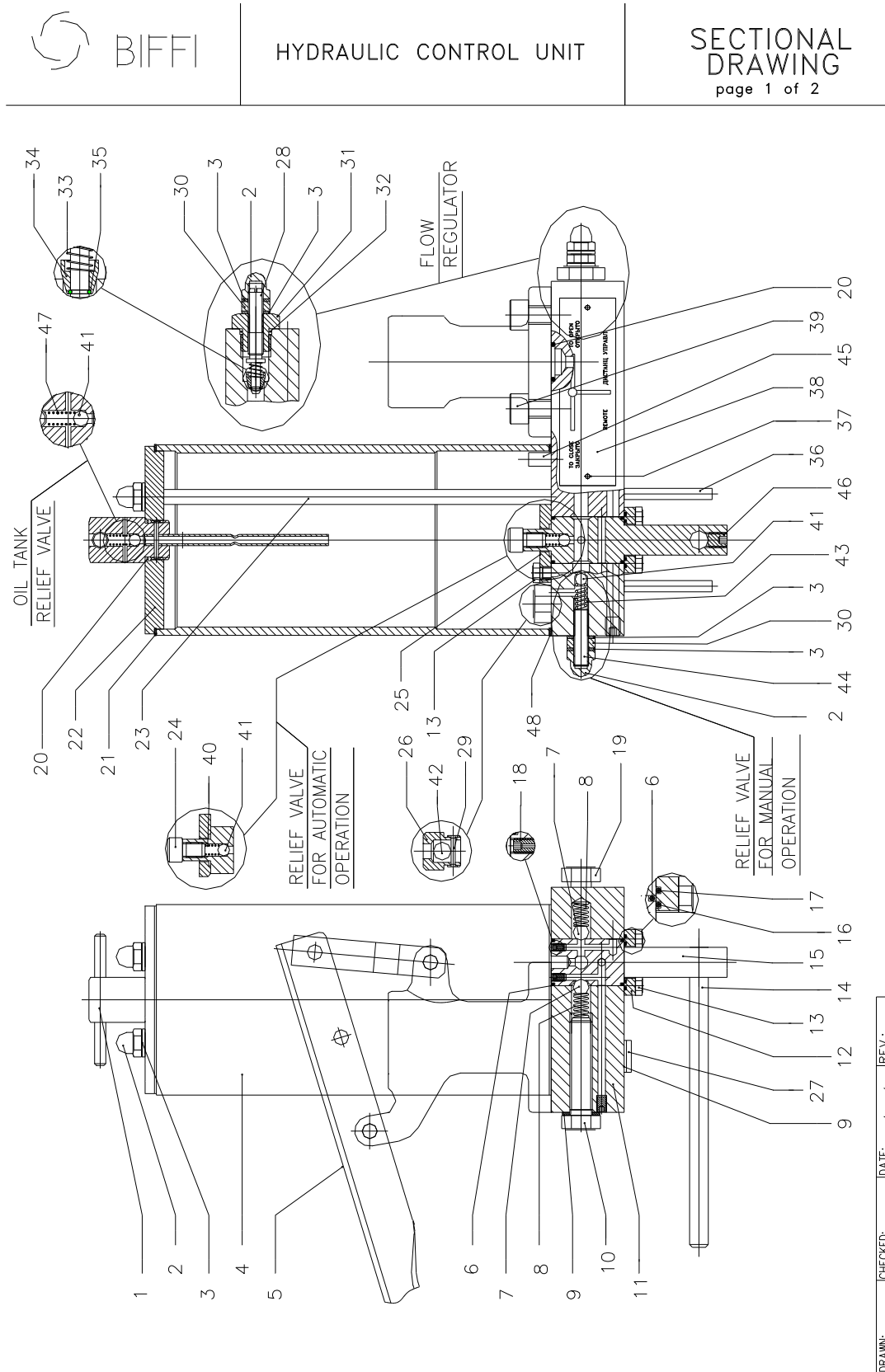

5.4 LUBRICATION OF MECHANISM

For normal duty the scotch yoke mechanism of the actuator is lubricated "for life". In case of high load and high frequency of operation it may be necessary to periodically restore lubrication: it is advisable to apply a generous coating of grease on the contact surfaces of the yoke and bushings, on the yoke link grooves, on the sliding blocks, on the guide bar.

For this operation it is necessary to disassemble the mechanism cover. In larger actuators the lubrication can be performed through the inspection holes of the cover after removing the plugs.

The following grease is used by BIFFI for standard working temperature and suggested for re-lubrication:

AGIP MU/EP/2	AEROSHELL GREASE 7 or equivalent
<p>To be used in standard temperature conditions (-30°C/+85°C)</p> <p>NLGI consistency: 2</p> <p>Worked penetration: 280 dmm</p> <p>ASTM Dropping Point: 185°C</p> <p>Base oil viscosity at 40°C: 160 mm²/s</p> <p>ISO Classification: L-X-BCHB 2</p> <p>DIN 51 825: KP2K – 20</p> <p>Equivalent to: ESSO BEACON EP2 BP GREASE LTX2 SHELL ALVANIA GREASE R2 ARAL ARALUB HL2 CHEVRON DURALITH GREASE EP2 CHEVRON SPHEEROL AP2 TEXACO MULTIFAK EP2 MOBILPLEX 47 PETROMIN GREASE EP2</p>	<p>To be used in low temperature conditions (-60°C/+65°C)</p> <p>Colour: Buff</p> <p>Physical state: Semi-solid at ambient temperature</p> <p>Odour : Slight</p> <p>Density : 966 Kg/m³ at 15°C</p> <p>Flash Point : >215°C (COC)(Based on synthetic oil)</p> <p>Dropping point : 260°C (ASTM D-566)</p> <p>Product code : 001A0065</p> <p>Infosafe No.: ACISO GB/eng/C</p>

5.4 DISMANTLING AND DEMOLITION

Before starting the disassembly a large area should be created around the actuator so to allow any kind of movement without problems of further risks created by work-site.



Before disassembling the actuator it is necessary to close the pneumatic feed line and discharge pressure from the cylinder of the actuator, from the control unit and from the accumulator tank, if present.

If actuator is still mounted onto the valve, loosen the threaded connections between valve and actuator (screws, tie rods, nuts)

Lift the actuator using the proper lifting points (see chapter B. pages from 8 to 13).

If the actuator needs storage, before demolition, see chapter B page 7.

The demolition of the actuator both concerning any electrical and mechanical parts should be made by specialized staff

Separate the parts composing the actuator according to their nature (ex. metallic, and plastic materials, fluids etc.) and send them to differentiated waste collection sites, as provided for by the laws and provisions in force.

6 Troubleshooting

6.1 FAILURE OR BREAKDOWN RESEARCH

Event	Possible cause	Remedy
Actuator does not work	Lack of power supply	Restore it
	Lack of pneumatic supply	Open line interception valve
	Blocked valve	Repair or replace
	Wrong position of the distributor of the manual hydraulic group	Restore correct position
	Failure of the control group	Call BIFFI Italia S.r.l. Customer Service
Actuator too slow	Low supply pressure	Restore (Sect. 1.4)
	Low supply pressure	Restore (Sect. 1.4)
	Wrong calibration of flow regulator valves	Restore (Sect. 3.6)
Actuator too fast	Wear of the valve	Replace
	High supply pressure	Restore (Sect. 1.4)
	Wrong calibration of flow regulator valves	Restore (Sect. 3.6)
Leakages on hydraulic or pneumatic circuits	Deterioration and/or damage to gaskets	Call BIFFI Italia S.r.l. Customer Service.
Incorrect position of the valve	Wrong adjustment of mechanical stops	Restore (Sect. 3.4)
	Wrong warning of microswitches	Restore (Sect. 3.5)
Hydraulic manual pump does not work	handle positioned on remote control	Position the handle on the indication of the operation to make
	Leakages on the check valve of the hydraulic control group	Call BIFFI Italia S.r.l. Customer Service

7 Layouts

7.1 SPARE PARTS ORDER

For spare parts order to the relevant BIFFI office please make reference to BIFFI order confirmation concerning all the supply, and serial number of the actuator (Sect. 1.2) for any specific spare part for a specific actuator model.

Please send every spare-parts request to :

BIFFI ITALIA s.r.l. - Servizio Assistenza Tecnica Clienti

Tel. : 0523-944523_____

Fax: 0523-941885__ e-mail: spareservice@biffi.it

please specify :

- 1. actuator model;*
- 2. BIFFI acknowledgement ;*
- 3. spare parts code;*
- 4. quantity;*
- 5. transport condition;*
- 6. involved people.*

7.2 PARTS-LIST FOR MAINTENANCE AND REPLACING PROCEDURE

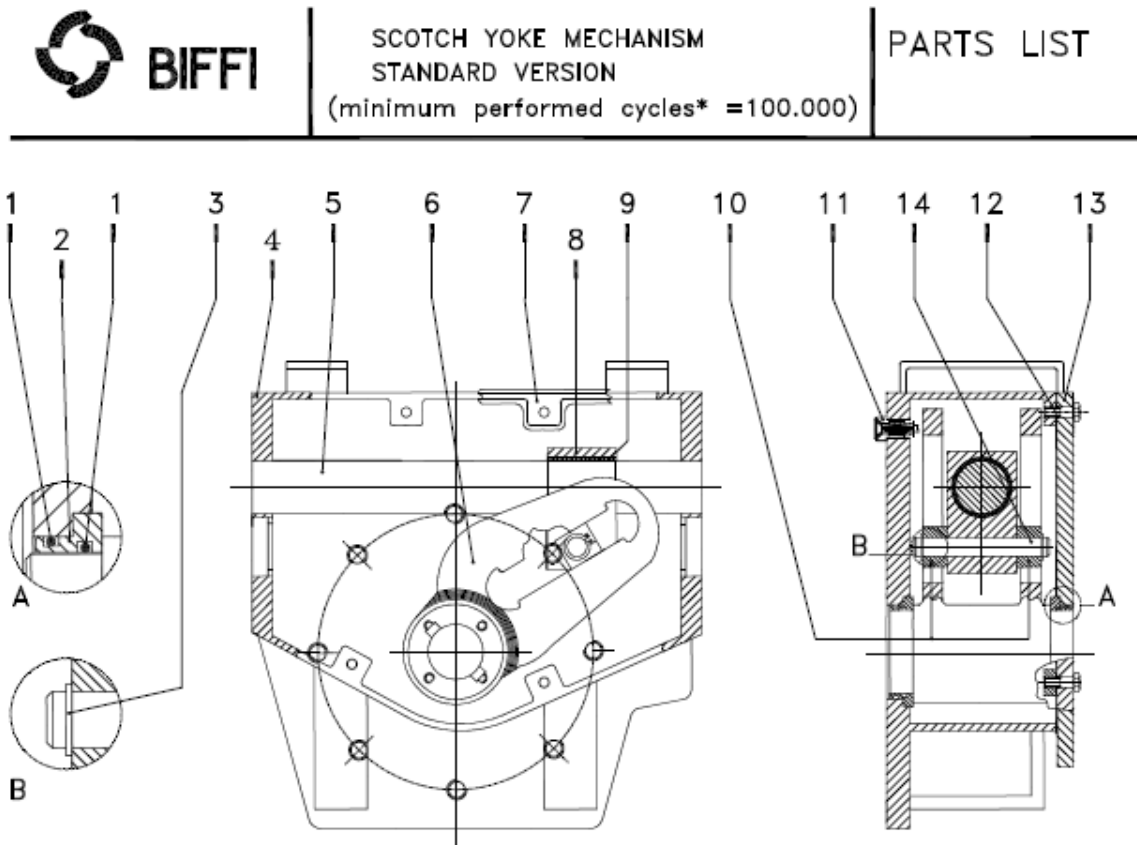
Table 1: Scotch-yoke mechanism

ITEM	Q.ty	DESCRIPTION	MATERIAL
1	4	O - ring	NBR rubber ●
2	2	Yoke bushing	Bronze
3	2	Retainer ring	Stainless steel
4	1	Housing	Carbon steel
5	1	Guide bar	Alloy steel
6	1	Yoke	Carbon steel
7	1	Cover gasket	SBR+Cellulose+Fillers ●
8	1	Guide block	Carbon steel
9	1	Bushing	Steel + Bz + Teflon
10	2	Sliding block	Bronze
11	1	Vent valve	Stainless steel ●
12	12	Screw	Carbon steel
13	1	Cover	Carbon steel
14	1	Guide block pin	Alloy steel

● RECOMMENDED SPARE PARTS

* CYCLES PERFORMED BY ACTUATOR IN A 25 YEARS EXPECTED LIFETIME – THE MINIMUM PERFORMED CYCLES ARE GUARANTEED BY BIFFI BASED ON SERVICE CONDITIONS LISTED:

ALL THE VALVE REQUIRED TORQUES HAVE TO BE LOWER THAN ACTUATOR MAX OPERATING TORQUE (MOT)

THE RATIO BETWEEN VALVE REQUIRED RUNNING TORQUE AND ACTUATOR MAX OPERATING TORQUE (MOT) HAS TO BE >1.5

THE ACTUATOR MECHANISM HAS TO BE LUBRICATED IN ACCORDANCE WITH INDICATION GIVEN ON THIS IOM



SCOTCH YOKE MECHANISM
HEAVY DUTY VERSION
(minimum performed cycles* =1.000.000)

PARTS LIST

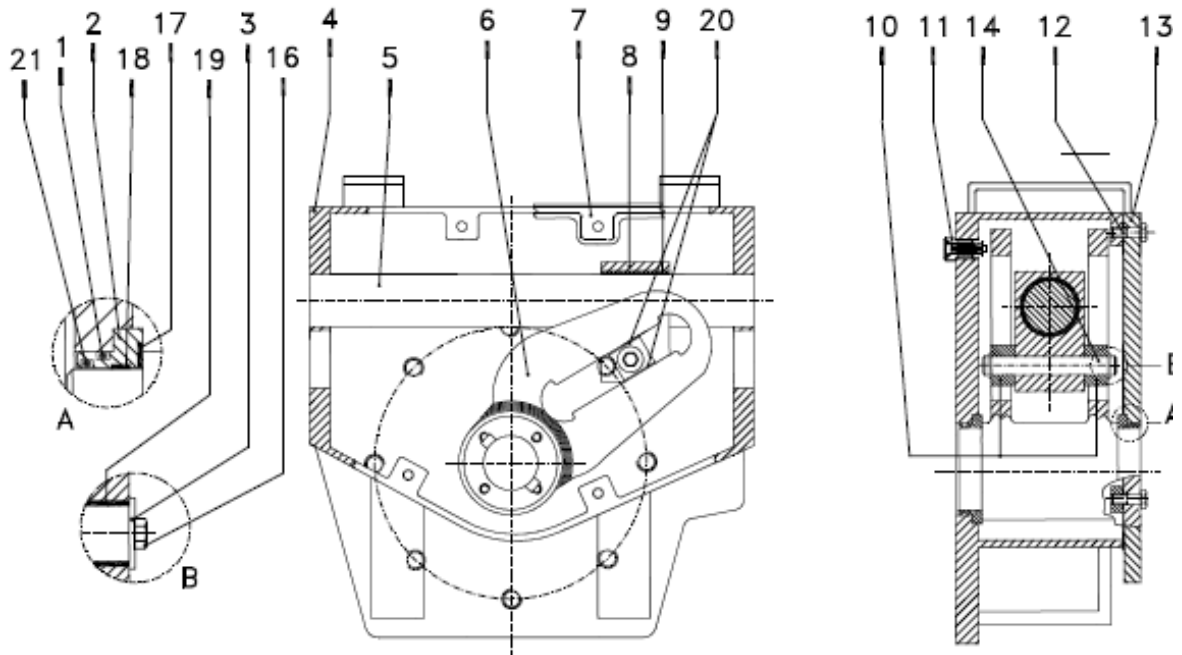

ITEM	Q.ty	DESCRIPTION	MATERIAL
1	2	O – ring	NBR rubber ●
2	2	Yoke bushing	Carbon steel
3	2	Washer	Stainless steel
4	1	Housing	Carbon steel
5	1	Guide bar	Alloy steel
6	1	Yoke	Carbon steel
7	1	Cover gasket	SBR + Cellulose + fillers ●
8	1	Guide block	Carbon steel
9	1	Bushing	Steel + Fiberglide
10	2	Sliding block	Carbon steel
11	1	Vent valve	Stainless steel+fluorosiliconic rubber ●
12	12	Screw	Carbon steel
13	1	Cover	Carbon steel
14	1	Guide block pin	Alloy steel
15			
16	2	Screw	Stainless steel
17	2	Yoke supporter washer	Ertacetal
18	2	Yoke bushing seat	Steel + Fiberglide
19	2	Guide block pin bushing	Steel + Fiberglide
20	4	Sliding block seat	Steel + Fiberglide
21	2	O – ring	NBR rubber ●

* CYCLES PERFORMED BY ACTUATOR IN A 25 YEARS EXPECTED LIFETIME – THE MINIMUM PERFORMED CYCLES ARE GUARANTEED BY BIFFI BASED ON SERVICE CONDITIONS LISTED:
ALL THE VALVE REQUIRED TORQUES HAVE TO BE LOWER THAN ACTUATOR MAX OPERATING TORQUE (MOT)
THE RATIO BETWEEN VALVE REQUIRED RUNNING TORQUE AND ACTUATOR MAX OPERATING TORQUE (MOT) HAS TO BE >1.5
THE ACTUATOR MECHANISM HAS TO BE INSPECTED,LUBRICATED, SEALS AND GASKETS HAVE TO BE REPLACED AFTER EACH 200.000 CYCLES

● RECOMMENDED SPARE PARTS

Table 2: pneumatic cylinder

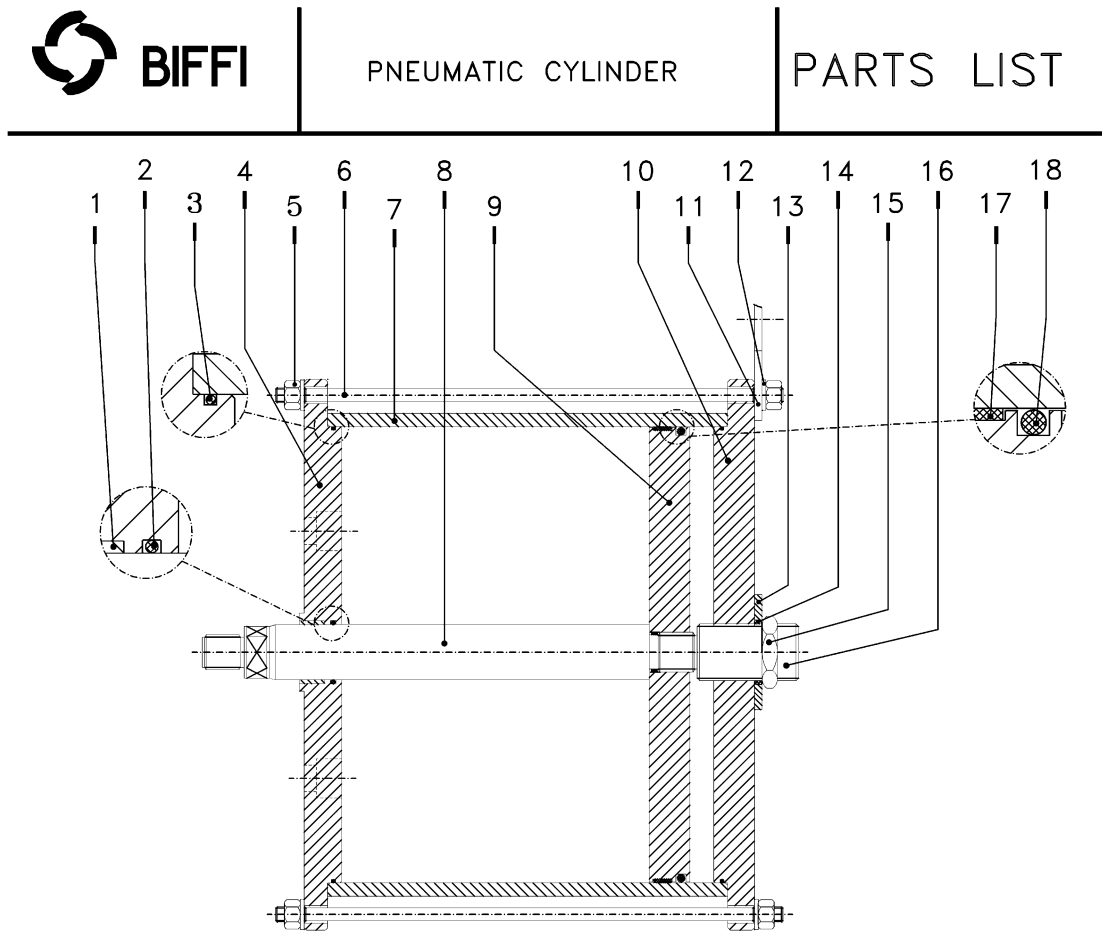

ITEM	Q.ty	DESCRIPTION	MATERIAL
1	1	Piston rod bushing	Steel+Bz+Teflon
2	1	O-Ring	NBR
3	2	O-Ring	NBR
4	1	Head flange	Carbon steel
5	12	Nut	Carbon steel
6	6	Tie rod	Alloy steel
7	1	Cylinder tube	Carbon steel
8	1	Piston rod	Alloy steel
9	1	Piston	Carbon steel
10	1	End flange	Carbon steel
11	1	Lifting eyelet	Carbon steel
12	2	Spring washer	Carbon steel
13	1	Washer	Carbon steel
14	1	Sealing washer	PVC
15	1	Nut	Carbon steel
16	1	Stop setting screw	Carbon steel
17	1	Guide sliding ring for piston	Teflon+Graphite
18	1	O-Ring	NBR

● RECOMMENDED SPARE PARTS

Table 5: Hydraulic control unit MHP

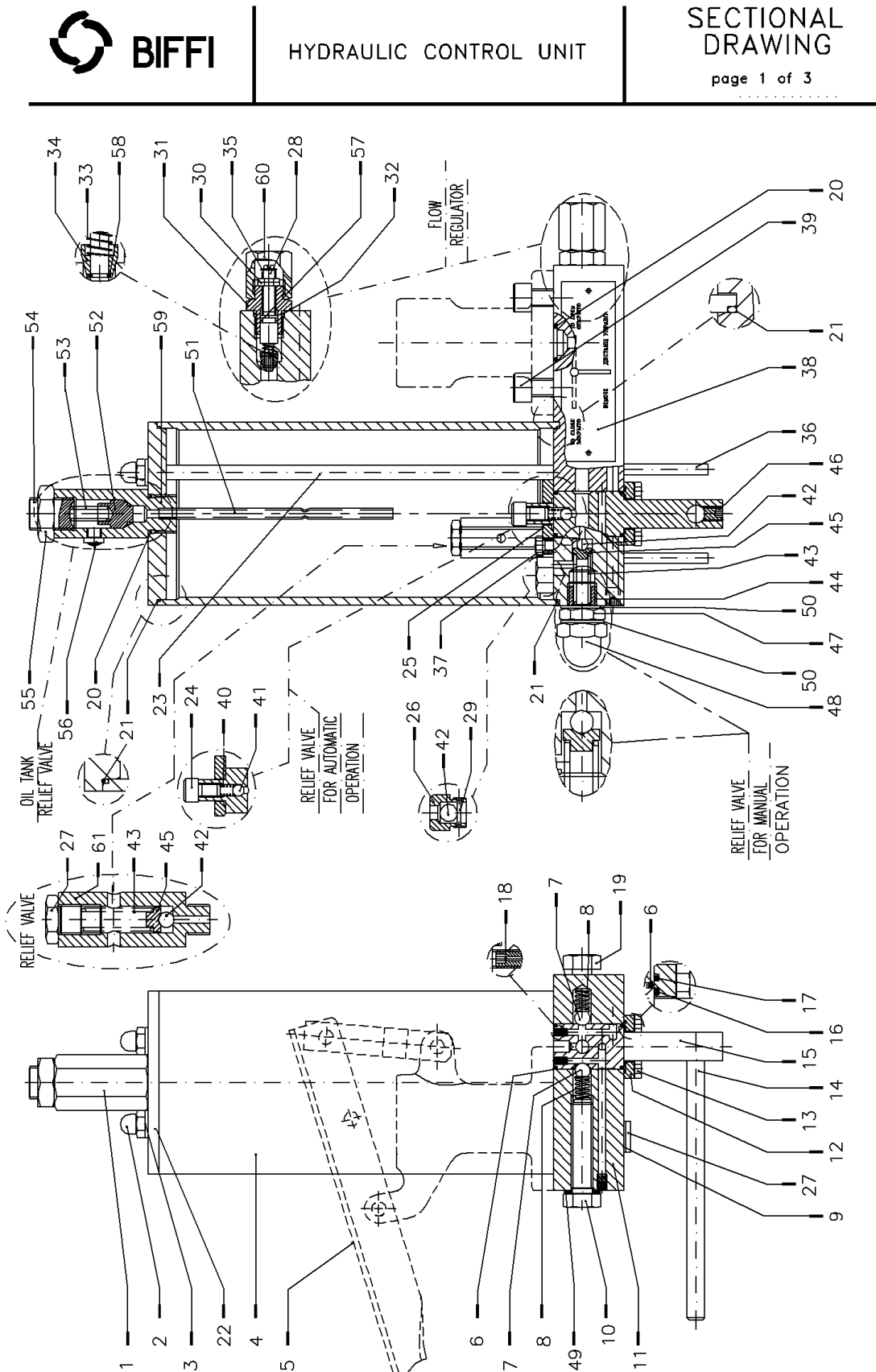



BIFFI
HYDRAULIC CONTROL UNIT
PARTS LIST

page 2 of 3

ITEM	Q.ty	DESCRIPTION	MATERIAL
1	1	Dipstick	
2	2	Cap nut	Carbon steel
3	2	Washer	Carbon steel + rubber
4	1	Hydraulic tank	Carbon steel
5	1	Hand pump	See attached table
6	2	O-ring	Fluorosilicon rubber ●
7	2	Ball	Stainless steel
8	2	Spring	Spring steel
9	1	Washer	Carbon steel + rubber
10	1	Screw	Carbon steel
11	1	Plate	Carbon steel
12	1	Flange	Aluminium
13	4	Screw	Carbon steel
14	1	Lever	Carbon steel
15	1	Distributor	Stainless steel
16	1	O-ring	Fluorosilicon rubber ●
17	1	O-ring	Fluorosilicon rubber ●
18	1	Nozzle	Carbon steel
19	2	Screw	Carbon steel
20	3	O-ring	Fluorosilicon rubber ●
21	2	O-ring	Fluorosilicon rubber ●
22	1	Tank cover	Carbon steel
23	2	Tie rod	Carbon steel
24	1	Screw	Carbon steel
25	1	Flange	Aluminium
26	2	Check valve body	Aluminium
27	2	Plug	Carbon steel
28	2	Flow control valve setting screw	Stainless steel
29	2	Spring pin	Stainless steel
30	2	Nut	Carbon steel
31	2	Flange	Carbon steel
32	2	O-ring	Fluorosilicon rubber ●
33	2	Spring	Spring steel
34	2	Plug	Stainless steel
35	2	Retainer ring	Spring steel
36	2	Spring pin	Carbon steel
37	4	Screw	Carbon steel
38	1	Operation instruction plate	Stainless steel
39	4	Screw	Carbon steel
40	1	Spring	Stainless steel
41	1	Ball	Stainless steel
42	4	Ball	Stainless steel
43	2	Spring	Spring steel
44	1	Relief valve setting screw	Stainless steel
45	2	Spring pin	Carbon steel
46	1	Screw	Alloy steel
47	1	Spring	Stainless steel
48	1	Nut	Carbon steel
49	1	Washer	Carbon steel + rubber
50	2	Washer	Carbon steel + rubber
51	1	Dipstick	Stainless steel
52	1	Plug + o-ring	●
53	1	Spring	Stainless steel
54	1	Screw	Alloy steel
55	1	Nut	Carbon steel
56	1	Silencer	Brass
57	2	O-ring	Fluorosilicon rubber ●
58	2	Retainer ring	Spring steel
59	1	Dipstick body	Aluminium
60	2	Nut	Carbon steel
61	1	Relief valve body	Aluminium

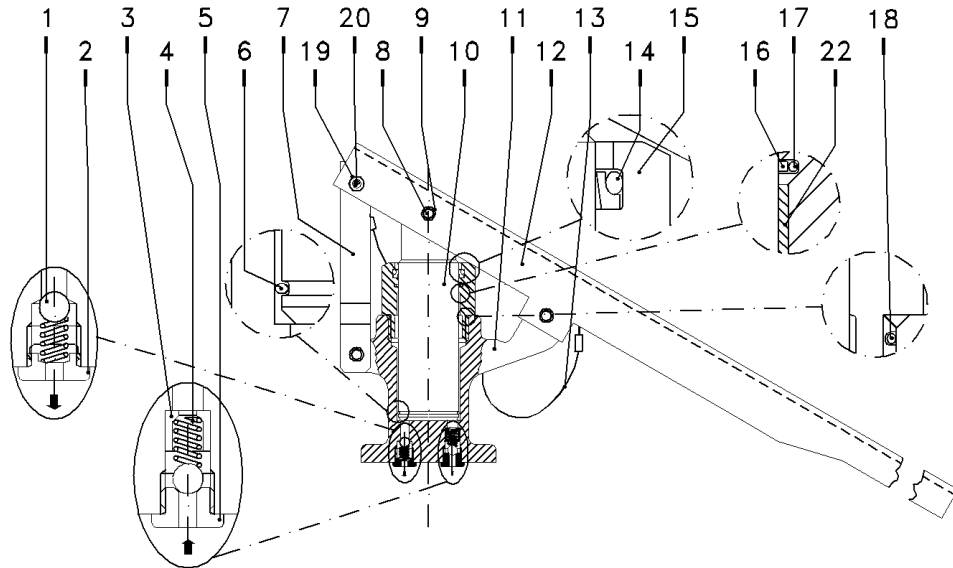
● RECOMMENDED SPARE PARTS



ITEM	Q.ty	DESCRIPTION	MATERIAL
1	2	Ball	Stainless steel
2	1	Delivery valve bush	Carbon steel
3	1	Suction valve bush	Carbon steel
4	2	Spring	Stainless steel
5	1	Suction valve seat	Carbon steel
6	1	Spring retainer ring	Carbon steel
7	1	Fork	Carbon steel
8	2	Pin	Stainless steel
9	4	Retainer ring	Carbon steel
10	1	Rod	Alloy steel
11	1	Body	Carbon steel
12	1	Lever	Carbon steel
13	1	Split pin with rope	Nylon + Carbon steel
14	1	Scraper ring	Teflon+Fluorosilicon rubber ●
15	1	Threaded bush	Alluminium
16	2	Rod seal ring	Teflon + graphite ●
17	2	O-Ring	Fluorosilicon rubber ●
18	1	O-Ring	Fluorosilicon rubber ●
19	1	Nut	Carbon steel
20	1	Screw	Carbon steel
21	1	Fork	Carbon steel
22	1	Piston rod bushing	Steel + BZ + Teflon

● RECOMMENDED SPARE PARTS

Table 6: Jackscrew manual override MSJ or MHW



MECHANICAL MANUAL OVERRIDE

PARTS LIST

Table 6

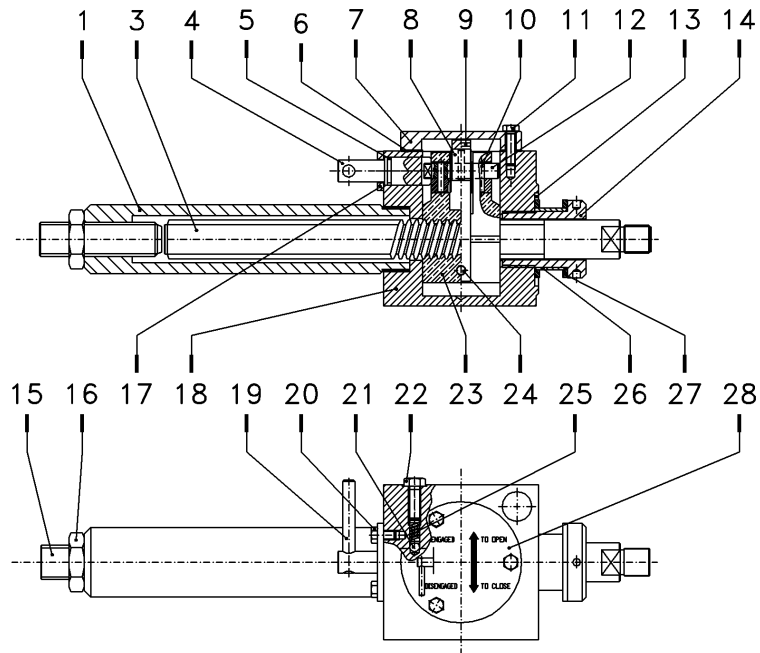

ITEM	Q.ty	DESCRIPTION	MATERIAL	R.S.P. (*)
1	1	Protection pipe	Carbon steel	
2				
3	1	Jack screw	Carbon steel	
4	1	Engagement lever pin	Stainless steel	
5	1	O-Ring	Fluorosilicon rubber	●
6	1	Cover gasket	Fiber	●
7	1	Cover	Carbon steel	
8	3	Cam	Alloy steel	
9	1	Fork	Carbon steel	
10	3	Spring pin	Stainless steel	
11	3	Screw	Carbon steel	
12	1	Screw nut operating cam	Alloy steel	
13	1	O-Ring	Fluorosilicon rubber	●
14	1	Thrust block ring nut	Alloy steel	
15	1	Screw	Carbon steel	
16	1	Nut	Carbon steel	
17	1	Flange	Carbon steel	
18	1	Body	Carbon steel	
19	1	Spring pin	Spring steel	
20	2	Screw	Carbon steel	
21	1	Ball 1/4"	Stainless steel	
22	1	Screw	Carbon steel	
23	1	Screw nut	Bronze	
24	1	Pin	Carbon steel	
25	1	Spring	Spring steel	
26	1	Bush	Bronze	
27	2	Thrust shoulder washer	Bronze	
28	1	Operating instruction plate	Aluminium	

(*) R.S.P. = RECOMMENDED SPARE PARTS

8 Date report for maintenance operations

Last maintenance operation date : (in factory, on delivery) :

..... exec. by :

..... exec. by :

..... exec. by :

Next maintenance operation date: exec. by :

..... exec. by :

..... exec. by :

Start-up date : (in factory, on delivery).....

(on plant)