

# **Biffi FG/FGC/FGH/FGHC Series Pneumatic Actuators**

Disassembly and Reassembly

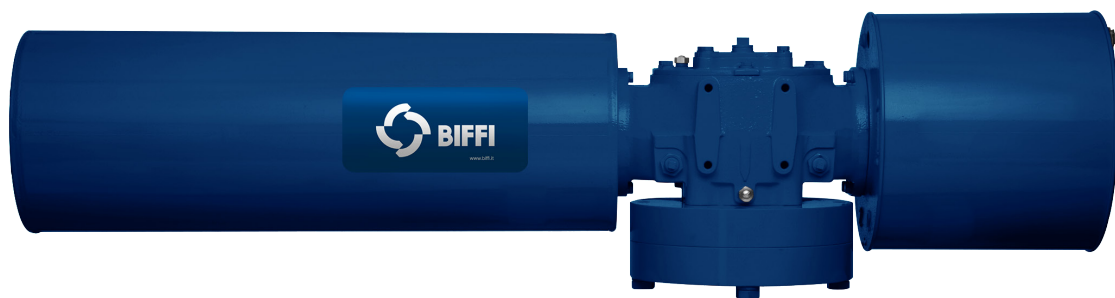

*This page is intentionally left blank.*

# Table of Contents

## Section 1: Introduction

1.1	General Service Information .....	1
1.2	Definitions .....	2
1.3	General Safety Information .....	2
1.4	Biffi Reference Materials .....	3
1.5	Service Support Items .....	3
1.6	Operating Media .....	4
1.7	Lubrication Requirements .....	4
1.8	General Tool Information .....	4
1.9	Actuator Storage .....	5
1.10	Actuator Installation .....	5
1.11	Actuator Start-Up .....	5
1.12	Actuator Operation .....	6

## Section 2: Actuator Disassembly

2.1	General Disassembly .....	7
2.2	Pneumatic Power Module Disassembly .....	8
2.3	Drive Module Disassembly .....	11
2.4	Blind End Cap Module Removal .....	14
2.5	M3 Handwheel or M3 Hex Drive Hub Removal .....	14
2.6	M3 Jackscrew Disassembly .....	15
2.7	Extended Stop Blind End Cap Disassembly .....	16

## Section 3: Actuator Reassembly

3.1	General Reassembly .....	17
3.2	Drive Module Reassembly .....	17
3.3	Pneumatic Power Module Reassembly .....	23
3.4	FG2 and FG3 Early Model Pneumatic Power Module Reassembly .....	28
3.5	Blind End Cap Module Reassembly .....	31
3.6	M3 Jackscrew Reassembly .....	32
3.7	M3 Handwheel or M3 Hex Drive Hub Installation .....	34
3.8	Extended Stop Blind End Cap Reassembly .....	35
3.9	Actuator Testing .....	35

**Section 4: Field Conversions**

- 4.1 Fail Mode Reversal (CW to CCW, or CCW to CW) for G and GH Only..... 37
- 4.2 Converting Double-Acting Actuator to Spring-Return ..... 37
- 4.3 Converting Spring-Return Actuator to Double-Acting ..... 37
- 4.4 Add an M3 Jackscrew to Blind End Cap Module ..... 38
- 4.5 Add an M3 Jackscrew to Power Module Outer End Cap ..... 38
- 4.6 Add an M3 Jackscrew to Spring Module..... 38
- 4.7 Add an Extended Stop (ES) to Blind End Cap Module..... 38
- 4.8 Add an Extended Stop (ES) to Power Module Outer End Cap..... 39
- 4.9 Add an Extended Stop (ES) to Spring Module..... 39

**Section 5: Module Removal and Installation**

- 5.1 Spring Module Removal..... 40
- 5.2 Spring Module Installation ..... 42
- 5.3 Pneumatic Power Module Removal..... 47
- 5.4 Pneumatic Power Module Installation ..... 48
- 5.5 FG2 Thru FG13 Powr-Swivl Removal  
(Excludes FGH/FGHC Model Actuators)..... 50
- 5.6 FG2 Thru FG13 Powr-Swivl Module Installation  
(Excludes FGH/FGHC Model Actuators)..... 51

**Section 6: Actuator Support Information**

- 6.1 FG/FGC/FGH/FGHC Module Weights by Item Number and  
Actuator Housing Size ..... 52
- 6.2 FG01 Tool Style and Wrench Size ..... 53
- 6.3 FG/FGC2 Tool Style and Wrench Size ..... 54
- 6.4 FG/FGC3 Tool Style and Wrench Size  
FGH2/FGHC2 for Item Number 3-20 to 3-130 ..... 54
- 6.5 FG/FGC4 Tool Style and Wrench Size  
FGH3/FGHC3 for Item Number 3-20 to 3-130 ..... 55
- 6.6 FG/FGC5 Tool Style and Wrench Size  
FGH4/FGHC4 for Item Number 3-20 to 3-130 ..... 55
- 6.7 FG/FGC7 Tool Style and Wrench Size  
FGH5/FGHC5 for Item Number 3-20 to 3-130 ..... 56
- 6.8 FG/FGC8 Tool Style and Wrench Size  
FGH7/FGHC7 for Item No 3-20 to 3-130 ..... 56
- 6.9 FG/FGC10 Tool Style and Wrench Size  
FGH8/FGHC8 for Item Number 3-20 to 3-130 ..... 57
- 6.10 FG13 Tool Style and Wrench Size  
FGH10/FGHC10 for Item Number 3-20 to 3-130 .....57
- 6.11 FG/FGC/FGH/FGHC Module Assemble Ratchet Extension Size ..... 58

<b>Section 7: Troubleshooting</b>	
7.1 Fault Insertion .....	59
7.2 Operational Test.....	60
<b>Section 8: Removal and Decommissioning</b>	
Removal and Decommissioning .....	61
<b>Section 9: Document Revision</b>	
Document Revision.....	62
<b>Appendix A: List of Tables</b>	
List of Tables.....	63
<b>Appendix B: List of Drawings</b>	
B.1 Part Number 116422, FGXXX Pneumatic Assembly Drawing, Sheet 1 of 2 .....	64
B.2 Part Number 116422, FGXXX Pneumatic Assembly Drawing, Sheet 2 of 2 .....	65
B.3 Part Number 115678, FGXX2XX Pneumatic Assembly Drawing, Sheet 1 of 2 .....	66
B.4 Part Number 115678, FGXX2XX Pneumatic Assembly Drawing, Sheet 2 of 2 .....	67
B.5 Part Number 115674, FGXXX-SRX Pneumatic Assembly Drawing, Sheet 1 of 2 .....	68
B.6 Part Number 115674, FGXXX-SRX Pneumatic Assembly Drawing, Sheet 2 of 2 .....	69
B.7 Part Number 140952, FGH/FGHCXXX-SRX Pneumatic Assembly Drawing, Sheet 1 of 2 .....	70
B.8 Part Number 140952, FGH/FGHCXXX-SRX Pneumatic Assembly Drawing, Sheet 2 of 2 .....	71
<b>Appendix C: Safety Instructions for Use in (Potential) Explosive Atmosphere</b>	
C.1 Intended Use .....	72
C.2 Explosive Atmosphere Marking.....	72
C.3 Safety Instructions.....	73
C.4 Maximum Temperatures.....	74

*This page is intentionally left blank.*

# Section 1: Introduction

## 1.1 General Service Information

- This service procedure is offered as a guide to enable general maintenance to be performed on Biffi™ FG/FGC01XXX, FG/FGC2XXX, FG/FGC3XXX, FG/FGC4XXX, FG/FGC5XXX, FG/FGC7XXX, FG/FGC8XXX, FG/FGC10XXX, FG13XXX, and FGH/FGHC2XXX, FGH/FGHC3XXX, FGH/FGHC4XXX, FGH/FGHC5XXX, FGH/FGHC7XXX, FGH/FGHC8XXX Spring-Return (SR) Series Single Power Module Pneumatic Actuators. These procedures can also be used on Biffi FGXX2XX Double-Acting Series Twin Power Modules Pneumatic Actuators.
- Normal recommended service interval for this actuator series is five years.

---

**NOTE:**

Storage time is counted as part of the service interval.

---

- This procedure is applicable with the understanding that all electrical power and pneumatic pressure has been removed from the actuator.
- Remove all piping and mounted accessories that will interfere with the module(s) that are to be worked on.
- This procedure should only be implemented by a technically competent technician who should take care to observe good workmanship practices.
- Numbers in parentheses ( ), indicate the bubble number (reference number) used on the Biffi Assembly Drawing and Actuator Parts List.
- This procedure is written using the stop screw side of the housing (1-10) as a reference and this side will be considered the front side of the actuator. The housing cover (1-20) will be the top of the actuator.
- Actuator module weights are listed in Section 6, Table 6.1.
- When removing seals from seal grooves, use a commercial seal removing tool or a small screwdriver with sharp corners rounded off.
- Use a non-hardening thread sealant on all pipe threads.

** CAUTION**

Apply the thread sealant per the manufacturer's instructions.

---

- Biffi recommends that disassembly of the actuator should be done in a clean area on a workbench.

## 1.2 Definitions

### **WARNING**

If not observed, user incurs a high risk of severe damage to actuator and/or fatal injury to personnel.

---

### **CAUTION**

If not observed, user may incur damage to actuator and/or injury to personnel.

---

### **NOTE:**

Advisory and information comments are provided to assist maintenance personnel to carry out maintenance procedures.

---

### **NOTE:**

This product is only intended for use in large-scale fixed installations excluded from the scope of Directive 2011/65/EU on the restriction of the use of certain hazardous substances in electrical and electronic equipment (RoHS 2).

---

### **ES:**

Extended stop screw (for travel stop adjustment over a full 100° travel range).  
ES is not intended for use as a manual override.

### **M3:**

Manual jackscrew override

### **FG/FGC/FGH/FGHC:**

Symmetric/Canted/High Pressure/High Pressure Canted (Canted Yoke)  
FG-Series actuator

## 1.3 General Safety Information

Products supplied by Biffi, in its “as shipped” condition, are intrinsically safe if the instructions contained within this Service Instruction are strictly adhered to and executed by well-trained, equipped, prepared and competent personnel.

### **WARNING**

For the protection of personnel working on Biffi actuators, this procedure should be reviewed and implemented for safe disassembly and reassembly. Close attention should be given to the WARNINGS, CAUTIONS and NOTES from this procedure.

---

**⚠ WARNING**

This procedure should not supersede or replace any customer's plant safety or work procedures. If a conflict arises between this procedure and the customer's procedures, the differences should be resolved in writing between an authorized customer's representative and an authorized Biffi representative.

---

## 1.4 Biffi Reference Materials

- Assembly Drawing for FG/FGC01 through FG/FGC10 and FG13 Double-Acting One Power Module Pneumatic Series Actuators: use part number 116422.
- Assembly Drawing for FG01 through FG13 Double-Acting Twin Power Module Pneumatic Series Actuators: use part number 115678.
- Assembly Drawing for FG/FGC01 through FG/FGC10 and FG13 Spring-Return One Power Module Pneumatic Series Actuators: use part number 115674.
- Assembly Drawing for FGH/FGHC 2 through 10, Spring-Return One Power Module Pneumatic Series Actuators: use part number 140952.

---

**NOTE:**

If you require a specific assembly drawing (IE: GXX-M3 OR HYD), please contact Biffi by phone +39 0523 944 411 or by email [biffisales@emerson.com](mailto:biffisales@emerson.com).

---

## 1.5 Service Support Items

- Biffi Module Service Kit

---

**NOTE:**

Although the below part numbers say FGXX, they can also be used on FG/FGC/FGH/FGHCXX actuators.

---

- Rod Extension Retainer Nut Tool  
For the correct part number for this tool, refer to the following table.

**NOTE:**

These tools are required only when extension rod assembly (1-50) or (9-50) is removed or when a new extension rod assembly is installed.

**Table 1. Rod Extension Retainer Nut Tool Part Number**

Actuator Model	Biffi Part Number	Actuator Model	Biffi Part Number
FG01	None Required	FG5/FG7	117369
FG2	123616	FG8/FG10	117368
FG3/FG4	117370	FG13	122849

- Commercial leak testing solution
- Non-hardening thread sealant

## 1.6 Operating Media

- Recommended to use clean, dry air or inert gas.
- Other gases may be used with direction from Biffi Engineering to evaluate any possible restrictions or modifications which may need to be made for compatibility.

## 1.7 Lubrication Requirements

**NOTE:**

Lubricants other than those listed below should not be used without prior written approval of Biffi Product Engineering.

All temperature services -50 to +350 °F / -45.5 to +176.6 °C use Biffi ESL-5 lubricant. ESL-5 lubricant is contained in the Biffi module service kit in tubes and the tubes are marked ESL-4, 5 and 10 lubricant.

## 1.8 General Tool Information

Tools: All tools/Hexagons are American Standard inch (Imperial).

Large adjustable wrench, two (2) large screwdrivers, Allen wrench set, set of open/box-end wrenches, rubber or leather mallet, torque wrench (up to 1600 lbf•ft / 2169 N•m), breaker bar and a drive socket set. For recommended tool and wrench sizes, refer to Section 6, Tables 6.2 to 6.10.

## 1.9 Actuator Storage

For applications where the actuator is not placed into immediate service, it is recommended that the actuator be cycled with regulated clean/dry pneumatic pressure at least once per month. Indoor storage, if available, is recommended for all actuators. Care should be taken to plug all open ports on actuator and controls to keep out foreign particles and moisture. Actuators should not be stored in an atmosphere that is harmful to resilient seals. Contact factory for extended storage period.

## 1.10 Actuator Installation

Since there are many valve and actuator combinations, it is not practical to include detailed instructions for each type. Mountings are designed to be as simple as possible to keep the guess work out of the installation.

Actuators are shipped from the factory with the travel stops adjusted for approximately 90° rotation. Generally, it is necessary to make slight travel stop adjustments once the actuator is installed onto the valve. Refer to the valve manufacturer's recommendations for specific requirements. When the valve has internal stops, the actuator should be adjusted at the same points.

---

**NOTE:**

The actual "stopping" should be done by the actuator. If the valve does not have internal stops, adjust the actuator to the full open position. Using this as a reference point, rotate the valve closed and adjust to the valve manufacturer's specifications for total rotation.

---

Good instrument practices are also recommended. Clean/dry regulated pneumatic pressure is essential for long service life and satisfactory operation. It should be noted that new pneumatic lines often have scale and other debris in them and these lines should be purged of all foreign material.

---

**NOTE:**

Scale and debris can damage control valves, solenoids and seals.

---

## 1.11 Actuator Start-Up

### 1.10.1 Pre-startup checks

1. Inspect to ensure the unit has been mounted onto valve properly. Gear flange mounting bolts, stem key, setscrew(s) are installed and secured.
2. No tubing damaged or accessories dislodged during the shipping or the installation.
3. Indicated position confirms valve position.
4. All switching valves in normal operating position as per schematic/instructions.

**1.10.2** Check connections

1. Pneumatic/hydraulic components connected as per schematic enclosed or in service manual supplied.
2. Pneumatic supply connected to the identified ports.
3. Electrical connection terminals are secured.
4. Wiring as per enclosed diagram or service manual supplied.

**NOTE:**

When actuator is first placed into service, it should be cycled with regulated pneumatic pressure. This is necessary because the seals have been stationary, causing them to take a "set". Therefore, the actuator should be operated through several cycles to exercise the seals so as to achieve a service ready condition.

**1.10.3** Speed of operation

The actuator's speed of operation is determined by a number of factors, including:

1. Power supply line length
2. Power supply line size
3. Power supply line pressure
4. Control valve and fitting orifice size
5. Torque requirements of the valve
6. Size of the actuator
7. Setting of speed controls
8. Hydraulic Manual Override (where available)

Due to the interaction of these variables, it is difficult to specify a "normal" operating time. Faster operating time may be obtained by using one or more of the following:

1. Larger supply lines
2. Larger control valve
3. Higher supply pressure \*
4. Quick exhaust valves

NOTE: \* Not to exceed maximum operating pressure of actuator or control components.

Slower operating time may be obtained by using flow control valves to meter the exhaust. Excessive exhaust flow metering may cause erratic operation.

## 1.12 Actuator Operation

**1.11.1** Controlled operation

Controlled operation is accomplished by pressurizing and/or depressurizing the appropriate cylinder inlet(s) of a double-acting. Do not exceed pressures indicated on actuator nameplate.

**1.11.2** Manual operation

All pressure must be vented or equalized on both sides of the pneumatic piston prior to manual operation.

# Section 2: Actuator Disassembly

## 2.1 General Disassembly

### WARNING

It is possible that the actuator may contain a dangerous gas and/or liquids. Ensure that all proper measures have been taken to prevent exposure or release of these types of contaminants before commencing any work.

This section is written to either completely disassemble the entire actuator or can be used to disassemble individual modules as needed (pneumatic power module or drive module, etc.).

### WARNING

Do not remove spring module while spring is compressed.

### WARNING

Actuators equipped with a spring cartridge mounted M3 jackscrew or an extended stop (ES) read warning tag wired to the spring cartridge cover plate.

- 2.1.1** When the spring module is to be removed, it should be removed from the drive module prior to the pneumatic power module removal or disassembly.
- 2.1.2** The pneumatic power module can be disassembled while still attached to the drive module or the pneumatic power module can be removed from the drive module and disassembled separate to the actuator (refer to Section 5, Module Removal and Installation).
- 2.1.3** To ensure correct reassembly — that is, with pneumatic power module or spring module on same end of drive module as before — mark or tag right (or left) and mark mating surfaces.
- 2.1.4** For spring module removal, refer to Section 5, step 5.1.

## 2.2 Pneumatic Power Module Disassembly

---

**NOTE:**

Review Section 2.1 - General Disassembly before proceeding with Pneumatic Power Module Disassembly.

---

---

**NOTE:**

If the actuator model is a FGXX2XX Series (two same size power modules with one module mounted on each side of the drive module) then do the following steps on both power modules simultaneously, or complete one power module and then repeat Section 2.2 on the second power module.

---

**⚠ WARNING**

If not already removed, disconnect all operating pressure from actuator power cylinders.

---

**⚠ WARNING**

If the actuator is spring-return, then the spring cartridge must be checked to verify that the spring(s) are in their extended position before the pneumatic power module is disassembled from the drive module (refer to Section 5.1 through step 5.1.6).

---

- 2.2.1** Mark and record location of the ports on outer end cap (3-80) and inner end cap (3-10).
- 

**NOTE:**

If actuator is equipped with a spring module complete step 2.2.2. If actuator is a double-acting model skip step 2.2.2 then go to step 2.2.3.

---

- 2.2.2** Remove breather assembly (12) from outer end cap (3-80).

- 2.2.3** Refer to assembly drawing sheet 2 of 2 Detail "E" in Appendix B. Remove two socket cap screws (3-130) with lockwasher (3-140) from outer end cap (3-80).
- 

**NOTE:**

If the power module is equipped with an M3 jackscrew remove the M3 jackscrew using Section 2.6.5 for FG/FGH01 models and Section 2.6.6 for FG/FGH2 and FG/FGH3 models.

---

- 2.2.4** Outer end cap (3-80) removal as follows:
- 2.2.4.1** FG/FGC01 through FG/FGC10, FG13, and FGH/FGHC2 through FGH/FGHC10 standard end cap (3-80) removal. Continue at step 2.2.5.
  - 2.2.4.2** FG/FGC01-M3 jackscrew disassembly from outer end cap (3-80)
    - 2.2.4.2.1** Remove M3 handwheel or M3 hex drive hub from M3 (3-290) per Section 2.5.
    - 2.2.4.2.2** Refer to assembly drawing sheet 2 of 2 Detail "E" in Appendix B. If not already removed, unscrew and remove two socket cap screws (3-130) with lockwasher (3-140) from outer end cap (3-80).
    - 2.2.4.2.3** Remove socket cap screw (3-130) with lockwasher (3-140) from keeper (3-360).
    - 2.2.4.2.4** Remove keeper (3-360) from outer end cap (3-80).
    - 2.2.4.2.5** Push jackscrew (3-290) back into the outer end cap far enough so that the jackscrew adapter (3-280) will not interfere with the removal of hex nuts (3-90). Continue at step 2.2.5.
  - 2.2.4.3** FG/FGC/FGH/FGHC02 and FG/FGC/FGH/FGHC3-M3 jackscrew disassembly from outer end cap (3-80).
    - 2.2.4.3.1** Remove M3 handwheel or M3 hex drive hub from M3 (3-290) per Section 2.5.
    - 2.2.4.3.2** Unscrew and remove hex flat nut (3-300) from FG2/FG3 M3 jackscrew (3-290).
    - 2.2.4.3.3** Unscrew and remove two socket cap screws (3-320) from FG2/FG3 M3 adapter (3-280).
    - 2.2.4.3.4** Remove M3 jackscrew (3-290) from outer end cap (3-80). Continue at step 2.2.5.
- 2.2.5** Remove two tie bar hex nuts (3-90) from outboard side of outer end cap (3-80).
- 2.2.6** The fit between cylinder (3-70) and outer end cap (3-80) is very tight. Break end cap free by tapping with a breaker bar on lip provided on the end cap. Remove outer end cap (3-80) from cylinder (3-70).

### CAUTION

Do not damage O-ring groove when removing end cap from cylinder.

### NOTE:

When removing cylinder (3-70) off of piston (3-30), tilt the cylinder 15 to 30° with respect to actuator centerline.

- 2.2.7** Remove cylinder (3-70) from inner end cap (3-10).

**⚠ CAUTION**

Do not use pipe wrench to remove tie bars.

**2.2.8** Tie bar removal:**NOTE:**

FG/FGC01, FG/FGC/FGH/FGHC2 and FG/FGC/FGH/FGHC3 models have flats on outboard end of tie bars (3-20) for wrench placement.

**2.2.8.1** Remove FG/FGC01, FG/FGC/FGH/FGHC2 and FG/FGC/FGH/FGHC3 tie bars (3-2) as follows:

**2.2.8.1.1** Unscrew tie bars (3-20) from inner end cap (3-10). Pull the tie bars out of the inner end cap far enough to expose the O-ring seals (4-80).

**2.2.8.1.2** Remove O-ring seals (4-80) from the inboard end of tie bars (3-20).

**2.2.8.1.3** Remove tie bars (3-20) by pulling the tie bars out and through piston (3-30).

**NOTE:**

FG/FGC4 models have flats on outboard end of tie bars (3-20) for wrench placement.

**NOTE:**

FG5 through FG13, and FGH/FGHC5 through FGH/FGHC10 models have a female square on the out board end of tie bars (3-20) for wrench placement.

**2.2.8.2** Remove FG4 through FG13 tie bars (3-20) as follows: Unscrew and remove tie bars (3-20) from inner end cap (3-10) and piston (3-30).

**2.2.9** Remove piston as follows: (On early FG2 and FG3 models equipped with outboard and inboard tie bar nuts skip this step and go to step 2.2.11).

**2.2.9.1** Refer to assembly drawing sheet 2 of 2 Detail "D" in Appendix B. Remove two split ring halves (3-50) and one retainer ring (3-60) from outboard side of piston (3-30).

**NOTE:**

Piston (3-30) acts as the retainer for inboard split ring halves (3-50). When removing the piston, be careful to not lose inboard split ring halves (3-50).

**2.2.9.2** Remove piston (3-30) and two split ring halves (3-50) from piston rod (3-40).

**NOTE:**

Steps 2.2.10 is used only on early FG2 and FG3 models equipped with outboard and inboard tie bar nuts.

---

**2.2.10** Remove early model FG2 and FG3 pistons as follows:

**2.2.10.1** Refer to assembly drawing sheet 2 of 2 Detail "D" in Appendix B. Remove two split ring halves (3-50) and one retainer ring (3-60) from inboard side of piston (3-30).

---

**NOTE:**

Piston (3-30) acts as the retainer for outboard split ring halves (3-50).

---

**2.2.10.2** Slide piston (3-30) toward the inner end cap (3-10) until the outboard split ring halves is exposed enough for removal. Remove outboard split ring halves from piston rod (3-40).

**2.2.10.3** Remove piston (3-30) and two split ring halves (3-50) from piston rod (3-40).

**2.2.11** Remove O-ring seal (4-70) from piston rod (3-40).

**2.2.12** Remove hex cap screws (3-100) with lockwashers (3-110) from housing (1-10).

**2.2.13** Remove inner end cap (3-10) off of piston rod (3-40).

---

**NOTE:**

On early model FG2 and FG3 actuators remove two hex nuts (3-90) from housing (1-10). These two nuts will be loose after tie bars (3-20) are removed in step 2.2.8.1 and will be located in the area where the piston rod passes through the housing (1-10).

---

**NOTE:**

The piston rod (3-40) removal as outlined in step 2.2.14 is only required when the piston rod is being replaced or when the drive module is to be disassembled.

---

**2.2.14** Unscrew and remove piston rod (3-40) from drive module.

## 2.3 Drive Module Disassembly

---

**NOTE:**

Review Section 2 - General Disassembly before proceeding with drive module disassembly.

---

**2.3.1** If not already removed, remove piston rod (3-40) from drive module.

---

**NOTE:**

If the actuator is equipped with submerged stop screws with stop screw covers (1-195) then proceed to and complete steps 2.3.2.1 and 2.3.2.2 prior to doing step 2.3.2.

---

- 2.3.2** Mark stop screws (1-180) left and right. The setting of stop screws (1-180) should be checked and setting recorded before stop screws are loosened or removed.
- 

**NOTE:**

Stop screws will be removed later in this procedure.

---

- 2.3.2.1** Hold stop screw cover (1-195) in place and remove pipe plug (1-260).

- 2.3.2.2** Hold submerged stop screw (1-180) in place and remove stop screw cover (1-195).
- 

**NOTE:**

For steps 2.3.3 through 2.3.10, refer to Assembly Drawing sheet 2 of 2 Section A-A in Appendix B, Detail "F" on drawing part number 115674 and Detail "G" on drawing part number 116422 in Appendix B.

---

- 2.3.3** Before removing position indicator (1-220), record or mark its position. Remove position indicator (1-220).
- 

**NOTE:**

Step 2.3.4 is used only on FG01, FGH/FGHC 2 and FGH/FGHC 3 drive modules. Drive modules FGH/FGHC4 through FG/FGC/FGH/FGHC10 and FG13 will skip steps 2.3.4 and continue with step 2.3.5.

---

- 2.3.4** Remove one vent check assembly (13) from top of housing cover (1-20).
- 2.3.5** Unscrew and remove hex cap screws (1-160) with lockwashers (1-170) from yoke cover (1-150).
- 2.3.6** Remove yoke cover (1-150) from housing cover (1-20).
- 2.3.7** Mark and record the orientation of the position indicator assembly (1-140) in relation to the top of yoke (1-70).
- 2.3.8** Remove position indicator assembly (1-140) from top of yoke (1-70).
- 2.3.9** Remove spring pin (1-100) from top of yoke (1-70).
- 2.3.10** Remove hex cap screws (1-110), with lockwashers (1-115) from housing cover (1-20).
- 

**NOTE:**

Steps 2.3.11 and 2.3.12 are used only on FG/FGC/FGH/FGHC5, FG/FGC/FGH/FGHC7, FG/FGC/FGH/FGHC8 and 10 drive modules. Drive modules FG/FGC01, FG/FGC/FGH/FGHC2 through 4 will skip steps 2.3.11 and 2.3.12 and continue with step 2.3.13.

---

- 2.3.11** Remove hex cap screws (1-120), with lockwashers (1-115), from housing cover (1-20).
- 2.3.12** Using hex cap screws (1-110), install into holes vacated by hex cap screws (1-120). Use these hex cap screws to jack the housing cover up for removal. Alternately rotate the hex cap screws clockwise until housing cover (1-20) is clear of housing (1-10).

---

**NOTE:**

FG/FGC01, FG/FGC/FGH/FGHC2 through 4 model housing cover will have cast tabs for placing prying tools to aid in cover removal.

---

- 2.3.13** Remove housing cover (1-20) from housing (1-10).

---

**NOTE:**

Groove pins (1-130) will remain in housing cover (1-20) when housing cover is removed from housing (1-10). Groove pins (1-130) should not be removed from housing cover (1-20) unless they are damaged and require new replacements.

---

- 2.3.14** Refer to assembly drawing sheet 2 of 2 Detail "B" in Appendix B. Remove guide bar (1-90) from housing (1-10).
- 2.3.15** Remove top yoke pin thrust bearing (2-10) from top of yoke pin (1-80).
- 2.3.16** Rotate the arms of yoke (1-70) to the center position of housing (1-10).
- 2.3.17** Remove yoke (1-70) with yoke pin (1-80), guide block (1-30) and two yoke/guide block bushings (2-30), by lifting yoke up and out of the housing (1-10).
- 2.3.18** Remove bottom yoke pin thrust bearing (2-10) from inside bottom of housing (1-10).
- 2.3.19** Remove yoke pin (1-80) by inserting 3/8 in. -16 UNC screw into top of the yoke pin and pull straight up and out.
- 2.3.20** Remove guide block (1-30) from between the arms of yoke (1-70).
- 2.3.21** Remove yoke/guide block bushing (2-30) from top of guide block (1-30).
- 2.3.22** Remove yoke/guide block bushing (2-30) from the top of the lower yoke arm of yoke (1-70).

---

**NOTE:**

FG01 model actuators skip steps 2.3.23 through 2.3.25 and continue disassembly at step 2.3.26.

---

- 2.3.23** Refer to assembly drawing sheet 2 of 2 Detail "B" in Appendix B. Use Biffi tool part numbers 117368 (FG8/FG10), 117369 (FG5/FG7), 117370 (FG3/FG4), 122849 (FG13) or 123616 (FG2) and remove retention retainer nut assemblies (1-60) from guide block (1-30). On spring-return actuators also remove retention retainer nut assemblies (9-60). These tools can be used for FGC/FGH/FGHC models of equivalent size.

- 2.3.24** Remove extension rod assembly (1-50) from guide block (1-30).  
On spring-return actuators also remove rod extension assembly (9-50).

---

**NOTE:**

On FG/FGC models only (not FGH/FGHC), one spherical washer (1-40) will be removed from guide block (1-30) when extension rod assembly is removed. On spring-return actuators, one spherical washer (9-40) will also be removed from guide block (1-30). On FGH/FGHC actuators, there is no extension rod assembly; the piston rod is fastened directly into the guide block assembly instead.

---

- 2.3.25** Remove the remaining spherical washer (1-40) from guide block (1-30).  
On spring-return actuators also remove the remaining spherical washer (9-40) from guide block (1-30).
- 2.3.26** Unscrew and remove two stop screw nuts (1-190) from stop screws (1-180).
- 2.3.27** Unscrew and remove two stop screws (1-180) from front of housing (1-10).
- 2.3.28** Housing (1-10) vent check assembly removal as follows:
- 2.3.28.1** For FG01, FG/FGC/FGH/FGHC2 and FG/FGC/FGH/FGHC3 housing (1-10), unscrew and remove one vent check assembly (13) from the front of housing (1-10).
- 2.3.28.2** For FG/FGC/FGH/FGHC4 through FG/FGC/FGH/FGHC10 and FG13 housing (1-10) unscrew and remove two vent check assembly's (13) from the front of housing (1-10).
- 2.3.29** The following items do not need to be removed from their assembled locations unless being replaced by new items: Two guide bar bearings, two yoke bearings (2-40), yoke pin bearing and yoke pin thrust bearing (2-10).

## 2.4 Blind End Cap Module Removal

- 2.4.1** Remove hex cap screws (5-20), with spring lockwashers (5-30), from blind end cap (5-10).
- 2.4.2** Remove blind end cap (5-10) from end of housing (1-10).

## 2.5 M3 Handwheel or M3 Hex Drive Hub Removal

- 2.5.1** M3 HANDWHEEL OR HEX DRIVE HUB REMOVAL FROM M3 STUD
- 2.5.1.1** Using pin punch drive out two grooved pins (10-20) and (10-30) from handwheel hub or hex drive hub (10-10).
- 2.5.1.2** Remove handwheel or hex drive hub (10-10) from M3 stud (5-50).
- 2.5.2** EARLY MODEL FG2 and FG3 M3 HANDWHEEL AND HEX NUT REMOVAL FROM JACKSCREW
- 2.5.2.1** Remove hex nut, lockwasher from M3 jackscrew.
- 2.5.2.2** Remove handwheel from M3 jackscrew.
- 2.5.2.3** Using pin punch drive out spiral pin from outboard end of M3 jackscrew.
- 2.5.2.4** Remove hex nut from M3 jackscrew and handwheel.

## 2.6 M3 Jackscrew Disassembly

---

**NOTE:**

The jackscrew bearing retainer (7-110)/(5-110), needle bearing thrust washer assembly (7-100)/(5-100) or retainer ring (7-90)/(5-90) does not require disassembly from the jackscrew assembly (7-40)/(5-50) except for the need to replace worn parts. For disassembly of these items refer to step 2.6.7. Remove M3 handwheel or M3 hex drive hub per Section 2.5.

---

**2.6.1 FG01-M3 JACKSCREW DISASSEMBLY FROM BLIND END CAP**

**2.6.1.1** Remove M3 handwheel or M3 hex drive hub per Section 2.5.

---

**NOTE:**

See note on Section 2.6 before proceeding with steps 2.6.1.2 through 2.6.1.4.

---

**2.6.1.2** Unscrew and remove socket cap screw (5-120) with lockwasher (5-130) from keeper (5-140).

**2.6.1.3** Remove keeper (5-140) from blind end cap (5-10).

**2.6.1.4** Remove M3 jackscrew (5-50) from blind end cap (5-10).

**2.6.2 FG2-M3 AND FG3-M3 JACKSCREW DISASSEMBLY FROM BLIND END CAP**

**2.6.2.1** Remove M3 handwheel or M3 hex drive hub per Section 2.5.

---

**NOTE:**

See note on Section 2.6 before proceeding with steps 2.6.2.2 through 2.6.2.4.

---

**2.6.2.2** Unscrew and remove hex flat nut (5-60) from FG2/FG3 M3 jackscrew.

**2.6.2.3** Unscrew and remove two socket cap screws (5-120) from FG2/FG3 M3 adapter.

**2.6.2.4** Remove M3 jackscrew (5-50) from blind end cap (5-10).

**2.6.3 FG01-SR-M3 JACKSCREW DISASSEMBLY FROM SR-M3 ADAPTER PLATE**

**2.6.3.1** Remove M3 handwheel or M3 hex drive hub per Section 2.5.

---

**NOTE:**

See note on Section 2.6 before proceeding with steps 2.6.3.2 through 2.6.3.4.

---

- 2.6.3.2** Unscrew and remove hex flat nut (7-50) from M3 jackscrew assembly (7-40).
- 2.6.3.3** Remove retainer ring (7-55) from M3 adapter (7-45).
- 2.6.3.4** Remove M3 jackscrew assembly (7-40) from M3-SR adapter plate (7-10).
- 2.6.4** FG2 AND FG3-SR-M3 JACKSCREW DISASSEMBLY FROM SR-M3 ADAPTER PLATE
  - 2.6.4.1** Remove M3 handwheel or M3 hex drive hub per Section 2.5.

---

**NOTE:**

See note on Section 2.6 before proceeding with step 2.6.4.2 through 2.6.4.4.

---

- 2.6.4.2** Unscrew and remove hex flat nut (7-50) from M3 jackscrew assembly (7-40).
- 2.6.4.3** Unscrew and remove two socket cap screws (7-120) from M3 adapter (7-40).
- 2.6.4.4** Remove M3 jackscrew (7-40) from M3-SR adapter plate (7-10).
- 2.6.5** M3 THRUST BEARING DISASSEMBLY FROM M3 JACKSCREW ASSEMBLY
  - 2.6.5.1** Remove M3 bearing retainer (5-110)/(7-110) from inboard end of M3 jackscrew assembly (5-50)/(7-40).
  - 2.6.5.2** Remove needle roller thrust bearing (5-100)/(7-100) from M3 bearing retainer (5-110)/(7-110).
  - 2.6.5.3** Remove retainer ring (5-90)/(7-90) from M3 jackscrew assembly (5-50)/(7-40).

## **2.7 Extended Stop Blind End Cap Disassembly**

- 2.7.1** Unscrew and remove hex nut (5-60) from ES stop screw (5-50).
- 2.7.2** Remove ES stop screw (5-50) from ES blind end cap (5-10).

## Section 3: Actuator Reassembly

### 3.1 General Reassembly

#### **⚠ CAUTION**

Only new seals, which are still within the seal's expectant shelf life, should be installed into the actuator being refurbished.

- 3.1.1** Remove and discard all old seals and gaskets.
- 3.1.2** All parts should be cleaned to remove all dirt and other foreign material prior to inspection.
- 3.1.3** All parts should be thoroughly inspected for excessive wear, stress cracking, galling and pitting. Attention should be directed to threads, sealing surfaces and areas that will be subjected to sliding or rotating motion. Sealing surfaces of the cylinder, tie bars and piston rod must be free of deep scratches, pitting, corrosion and blistering or flaking coating.

#### **⚠ CAUTION**

Actuator parts that reflect any of the above listed characteristics should be replaced with new parts.

- 3.1.4** Before installation, coat all moving parts with a complete film of lubricant. Coat all seals with a complete film of lubricant before installing into seal grooves.

#### **NOTE:**

The parts and seals used in the actuator will be assembled using lubricant as identified in Section 1.7.

- 3.1.5** For spring module installation, refer to Section 5, step 5.2.

### 3.2 Drive Module Reassembly

#### **NOTE:**

Review Section 3.1 - General Reassembly before proceeding with Drive Module Reassembly. Refer to assembly drawing sheet 2 of 2 Detail "B" in Appendix B for section drawing of guide block.

- 3.2.1** If guide bar bearing (2-20) is being replaced install new bearing into guide block (1-30).

---

**NOTE:**

The guide bar bearing (2-20) must be pressed into guide block guide bar bore with the seam located  $\pm 5^\circ$  of the top or bottom centerline as shown in Section A-A in Appendix B.

---

---

**NOTE:**

FG01 model actuators skip steps 3.2.2 through 3.2.13 and continue reassembly at step 3.2.14.

---

- 3.2.2** Lubricate guide block (1-30), two spherical washers (FG/FGC only) (1-40) and one extension rod assembly (FG/FGC only) (1-50).

---

**NOTE:**

Steps 3.2.3 to 3.2.13 for FG/FGC models only (not FGH/FGHC).

---

- 3.2.3** Install one spherical washer (1-40) into the side of guide block (1-30).

---

**NOTE:**

The spherical side of washer (1-40) will be facing to the outside of guide block (1-30).

---

- 3.2.4** Install second spherical washer (1-40) over threaded end of extension rod assembly (1-50).

---

**NOTE:**

The spherical side of the washer will go on the extension rod assembly facing the head of the extension rod assembly.

---

- 3.2.5** Install extension rod assembly (1-50) into guide block (1-30) and up against the first spherical washer (1-40).
- 3.2.6** Install extension retainer nut assembly (1-60) over extension rod assembly (1-50) and screw into guide block (1-30).
- 3.2.7** Tighten extension retainer nut assembly (1-60) until extension rod assembly (1-50) cannot move. Back off the extension retainer nut assembly (1-60) just enough to allow for extension rod assembly (1-50) to move freely.

**NOTE:**

Steps 3.2.8 through 3.2.13 are to be completed when the actuator is equipped with a spring module. If the actuator is double-acting then skip steps 3.2.8 through 3.2.13 and continue actuator reassembly starting with step 3.2.14.

---

**3.2.8** Lubricate two spherical washers (9-40) and one extension rod assembly (9-50).

**3.2.9** Install one spherical washer (9-40) into the side of guide block (1-30).

---

**NOTE:**

The spherical side of washer (9-40) will be facing to the outside of guide block (1-30).

---

**3.2.10** Install second spherical washer (9-40) over threaded end of extension rod assembly (9-50).

---

**NOTE:**

The spherical side of the washer will go on the extension rod assembly facing the head of the extension rod assembly.

---

**3.2.11** Install extension rod assembly (9-50) into guide block (1-30) and up against the first spherical washer (9-40).

**3.2.12** Install extension retainer nut (9-60) over extension rod assembly (9-50) and screw into guide block (1-30).

**3.2.13** Tighten extension retainer nut assembly (9-60) until extension rod assembly (9-50) cannot move. Back off the extension retainer nut assembly (9-60) just enough to allow for extension rod assembly (9-50) to move freely.

---

**NOTE:**

Steps 3.2.14 and 3.2.15 are to be completed when the actuator is double-acting and equipped with a blind end cap extended stop screw.

---

**3.2.14** Install guide block stop plug (5-50) into guide block (1-30).

**3.2.15** Install and tighten rod extension retainer nut assembly (5-80) over guide block stop plug (5-50) and screw into guide block (1-30).

---

**NOTE:**

Consult Biffi service team for yoke bearing, yoke pin bearing or yoke/guide block bushing installation information.

---

- 3.2.16** If the two yoke bearings (2-40) are being replaced, install new bearing into housing cover (1-20) and housing (1-10).

---

**NOTE:**

The yoke bearing (2-40) must be pressed into housing (1-10) and housing cover (1-20). Install the yoke bearings with the bearing seam located  $45^\circ \pm 5^\circ$  from the yoke arm slot when yoke (1-70) is rotated to its full clockwise position.

---

- 3.2.17** If the two yoke pin bearings (2-10) are being replaced install new bearing into housing cover (1-20) and housing (1-10).

- 3.2.18** Lubricate two yoke/guide block bushings (2-30) and install onto top and bottom sides of guide block (1-30).

---

**NOTE:**

The guide block (1-30) should be already pre-assembled with extension rod assembly and associated parts assembled in the guide block.

---

- 3.2.19** Install guide block (1-30), with yoke guide block bearings (2-30), between arms of yoke (1-70).

- 3.2.20** Install one O-ring seal (2-50) into inner diameter seal groove in the bottom of housing (1-10).

- 3.2.21** Coat the bearing surfaces of yoke (1-70) with lubricant and install into housing (1-10).

- 3.2.22** Align hole in guide block (1-30) with the matching holes in the two yoke/guide block bushings (2-30) and the slots in the arms of yoke (1-70).

---

**NOTE:**

The yoke pin can be held in place by installing a screw into the 0.375-16UNC tapped hole in the upper end of yoke pin (1-80).

---

- 3.2.23** Install yoke pin (1-80) by inserting into the upper yoke arm, upper yoke/guide block bushing, guide block, lower yoke/guide block bushing, lower yoke arm and resting on lower yoke pin thrust bearing (2-10).

- 3.2.24** Install guide bar (1-90) into either side of housing (1-10) by inserting through the housing, through guide block and then insert the guide bar into the other side of housing (1-10).

- 3.2.25** Refer to Assembly Drawing sheet 2 of 2 Section A-A in Appendix B. Install spring pin (1-100) into the top of yoke (1-70).

- 3.2.26** Install position indicator assembly (1-140) onto the top of yoke (1-70) and over spring pin (1-100).

**NOTE:**

Refer to Section 2, step 2.3.7 for correct installation position.

**3.2.27** Install O-ring (2-50) into housing cover (1-20).

**3.2.28** Install O-ring seal (2-60) into housing cover (1-20).

**3.2.29** Install housing cover (1-20), being careful not to damage O-ring seals (2-50) and (2-60).

**3.2.30** Place lockwashers (1-115) onto hex cap screws (1-110).

**NOTE:**

On FG/FGC/FGH/FGHC7, 8, 10, and FG13 model actuators apply thread adhesive, LOCTITE® 242, to threads of hex cap screws (1-110). Reference assembly drawing note number 8.

**3.2.31** Install hex cap screws (1-110) with lockwashers (1-115) through housing cover (1-20) and into housing (1-10).

**NOTE:**

Leave hex cap screws (1-110) finger tight; do not tighten.

**NOTE:**

Do this step only if groove pins (1-130) have been pulled or if the pins are being replaced. Drive groove pins (1-130) through housing cover (1-20) and into housing (1-10). The groove pins should be flushed with the cover.

**3.2.32** Torque tighten hex cap screws (1-110) until a final lubricated torque, as listed in the following table, has been achieved.

**Table 2. Housing Cover Screw Quantity and Torque Table**

Model FG/FGC/ FGH/FGHC	Quantity	Torque (±5 Percent)		Model FG/FGC/ FGH/FGHC	Quantity	Torque (±5 Percent)	
		lbf•ft	N•m			lbf•ft	N•m
FG01	4	40	54	7	8	100	136
2	6	40	54	8	12	100	136
3	8	40	54	10	16	100	136
4	8	40	54	FG13	20	340	461
5	8	100	136	-	-	-	-

**NOTE:**

Complete step 3.2.34 on FG/FGC/FGH/FGHC5, 7, 8, 10 and FG13 model actuators. For FG01 and FG/FGC/FGH/FGHC2 through FG/FGC/FGH/FGHC4 model actuators, skip step 3.2.34 and proceed to step 3.2.35.

**3.2.33** On FG/FGC/FGH/FGHC5, 7, 8, 10 and FG13 models

**3.2.33.1** Place lockwashers (1-115) onto hex cap screws (1-120).

---

**NOTE:**

Hex cap screw (1-120) are only used as “hole” fillers and to protect threads from environment.

---

**3.2.33.2** Install and tighten hex cap screws (1-120) with lockwashers (1-115).

**3.2.34** Install thrust bearing (2-110) onto position indicator (1-140).

**3.2.35** Install O-ring seal (2-100) onto position indicator (1-140).

**3.2.36** Install upper bearing (2-120) into yoke cover (1-150).

**3.2.37** Install rod wiper (2-80) into yoke cover (1-150).

**3.2.38** Install O-ring seal (2-70) into yoke cover (1-150).

**3.2.39** Install yoke cover (1-150) onto housing cover (1-20) and over position indicator assembly (1-140).

---

**NOTE:**

During yoke cover installation, be careful not to damage O-ring seal (2-70) and rod wiper (2-80).

---

**3.2.40** Place lockwashers (1-170) onto hex cap screws (1-160).

**3.2.41** Install and tighten hex cap screws (1-160) with lockwashers through yoke cover (1-150) and into housing cover (1-20).

**3.2.42** Vent check assembly installation as follows:

**3.2.42.1** FG01, FG/FGC/FGH/FGHC2 and FG/FGC/FGH/FGHC3 housing (1-10) using pipe sealant install one vent check assembly (13) into the front of housing (1-10).

**3.2.42.2** FG01, FG/FGC/FGH/FGHC2 and FG/FGC/FGH/FGHC3 housing (1-10) using pipe sealant install one vent check assemble (13) into the top area of housing cover (1-20).

**3.2.42.3** FG/FGC/FGH/FGHC4, 5, 7, 8, 10 and FG13 housing (1-10) using pipe sealant install two vent check assemblies (13) into the front of housing (1-10).

**3.2.43** Refer to Section 2, step 2.3.3 for correct position indicator placement. Install position indicator (1-220) over the exposed shaft of position indicator assembly (1-140).

**3.2.44** Install stop screw nuts (1-190) onto stop screws (1-180).

**3.2.45** Install O-ring (2-90) onto stop screws (1-180).

**3.2.46** Install two stop screws (1-180) into two stop screw holes on the front of housing (1-10).

**3.2.47** Adjust both stop screws (1-180) back to settings recorded earlier in Section 2 at step 2.3.2.

**3.2.48** Tighten both stop screw nuts (1-190) securely.

## 3.3 Pneumatic Power Module Reassembly

### NOTE:

For early model FG2 and FG3 actuators with double nuts on the power module, use Section 3.4 for reassembly.

Refer to Section 2, step 2.1.3 for the correct installation location for piston rod (3-40).

The actuator must be in the appropriate overtravel position. Confirm overtravel position by observing the guide block (1-30) is against the inner wall of housing (1-10).

- 3.3.1** Lubricate piston rod (3-40) and insert through the side of housing (1-10).
- 3.3.1.1** For FG2 through FG13, screw piston rod (3-40) onto extension rod assembly (1-50).
- 3.3.1.2** For FG01 only, screw piston rod (3-40) onto guide block (1-30).
- 3.3.2** After confirming initial thread engagement rotate piston rod into extension rod assembly (1-50) as listed in the following table.

### WARNING

After initial thread engagement, the piston rod must be rotated clockwise the minimum number of turns listed in the following table.

**Table 3. Piston Rod Number of Turns Table**

Actuator Model FG/FGC/FGH/FGHC	Minimum Number of Turns
1	6
2	10
3	10
4	10
5	13
7	14
8	20
10	25
FG13	31

- 3.3.3** Torque tighten piston rod (3-40) to the lubricated torque as listed in the following table.

**Table 4. Piston Rod Required Torque Table**

Housing Model FG/FGC/FGH/FGHC	Torque (±5 Percent)		Housing Model FG/FGC/FGH/FGHC	Torque (±5 Percent)	
	N•m	lbf•ft		N•m	lbf•ft
FG01	122	90	7	325	240
2	122	90	8	325	240
3	122	90	10	325	240
4	325	240	FG13	325	240
5	325	240	-	-	-

- 3.3.4** Refer to assembly drawing sheet 2 of 2 Detail "C" in Appendix B. Install one rod wiper (4-10) into inner end cap (3-10).

- 3.3.5** Install one rod bushing (4-20) into inner end cap (3-10).

- 3.3.6** Coat one PolyPak® seal (4-30) with lubricant and install, lip first, into inner end cap (3-10).

### CAUTION

Install the PolyPak seal with energizer ring facing outboard side (away from housing).

- 3.3.7** Install one O-ring seal (4-90) into seal groove located on the inboard face of inner end cap (3-10).

- 3.3.8** Install inner end cap (3-10) on to housing (1-10).

### NOTE:

The pressure inlet port should be positioned in the same position as recorded in Section 2.2, step 2.2.1.

- 3.3.9** Place lockwashers (3-110) onto hex cap screws (3-100).

- 3.3.10** Install and tighten hex cap screws (3-100) (FGH/FGHC7 model will have 4 more bolts than the standard G and 2 more bolts on the FGH/FGHC8,10 models than the standard FG), with lockwashers, through housing (1-10) and into inner end cap (3-10).

- 3.3.11** Refer to assembly drawing sheet 2 of 2 Detail "D" in Appendix B. Install one O-ring seal (4-70) into the seal groove in piston rod (3-40).

- 3.3.12** Apply lubricant to two sets of rod T-seal components (4-50).

---

**NOTE:**

The T-seal is composed of one rubber seal and two split skive-cut back-up rings.

---

- 3.3.12.1** Install two sets of rod T-seals (4-50) into the internal diameter seal grooves of piston (3-30).
- 3.3.12.2** Install a back-up ring on each side of the T-seal.
- 3.3.12.3** When installing the back-up rings, do not align the skive-cuts.
- 3.3.12.4** If the back-up rings are too long and the rings overlap beyond the skive-cuts, then the rings must be trimmed with a razor sharp instrument.
- 3.3.13** Install two split ring halves (3-50) into the inner most groove in piston rod (3-40) and retain by installing the recessed area of piston (3-30) onto the piston rod and over the two split ring halves (3-50).
- 3.3.14** Install two split ring halves (3-50) into the piston rod, in front of the piston installed in the previous step, and retain with retainer ring (3-60).
- 3.3.15** Install one O-ring seal (4-40) onto the outer diameter seal groove of inner end cap (3-10).
- 3.3.16** Coat one D-ring seal (4-60) with lubricant and install into the piston external seal groove.

---

**NOTE:**

The flat side of the D-ring seal go down into the seal groove.

---

- 3.3.17** Coat two tie bars (3-20) with lubricant and install by carefully pushing tie bars through piston (3-30) and rod T-seal (4-50).
- 3.3.18** Screw tie bars (3-20) into inner end cap (3-10) and tighten until the threads bottom out.
- 3.3.19** Refer to assembly drawing sheet 2 of 2 Detail "E" in Appendix B. Coat two O-ring seals (4-80) with lubricant and install into outer end cap (3-80).
- 3.3.20** Apply lubricant to one O-ring seal (4-40) and install into the outer diameter O-ring groove of outer end cap (3-80).
- 3.3.21** Apply lubricant to the bore of cylinder (3-70).

** CAUTION**

If needed, when installing the cylinder, hammer on the end of the cylinder only with a non metallic object.

---

- 3.3.22** Install lubricated cylinder (3-70) over piston (3-30) and onto inner end cap (3-10). When installing the cylinder over the piston seal tilt cylinder 15 to 30° to piston rod.
- 3.3.23** Outer end cap (3-80) installation as follows: FG01-M3 use step 3.3.23.1, FG2-M3 and FG3-M3 use step 3.3.23.2, and standard outer end cap use step 3.3.23.3.

**NOTE:**

The outer end cap (3-80) pressure inlet port should be positioned in the same position as recorded in Section 2.2, step 2.2.1.

**3.3.23.1 FG01-M3 OUTER END CAP INSTALLATION**

**3.3.23.1.1** Apply a light coating of lubricant to threads of jackscrew (3-290).

**3.3.23.1.2** Screw jackscrew adapter (3-280) onto jackscrew (3-290).

**NOTE:**

The smaller round end of the jackscrew adapter will install on the jackscrew pointing to the outboard end of the jackscrew.

**3.3.23.1.3** Position the jackscrew with the inboard end of the jackscrew located with the needle bearing thrust washer assembly (3-350) up against or near the jackscrew adapter (3-280).

**3.3.23.1.4** Lightly lubricate O-ring seal (6-20) and install into O-ring groove on the outboard side of the jackscrew adapter (3-280).

**3.3.23.1.5** Insert jackscrew (3-290) through inboard side of the outer end cap (3-80).

**3.3.23.1.6** Install outer end cap (3-80) over tie bars (3-20) and into cylinder (3-70).

**3.3.23.1.7** Install tie bar nuts (3-90) onto tie bars (3-20).

**NOTE:**

Do not tighten nuts.

**3.3.23.1.8** Install the jackscrew adapter keeper (3-360) into the groove exposed on the outboard side of the jackscrew adapter (3-280).

**3.3.23.1.9** Lightly lubricate O-ring seal (6-30) and install onto the outboard end of the jackscrew. Push the O-ring (6-30) down the jackscrew until it contacts the jackscrew adapter (3-280).

**3.3.23.1.10** Install flat hex nut (3-300) onto jackscrew (3-290). Rotate the flat hex nut (3-290) until it is up against O-ring seal (6-30).

**3.3.23.1.11** Install outer end cap (3-80) over tie bars (3-20) and into cylinder (3-70). Continue at step 3.3.24.

**3.3.23.2 FG/FGC/FGH/FGHC 2 AND FG/FGC/FGH/FGHC 3-M3 OUTER END CAP INSTALLATION**

**3.3.23.2.1** Lightly lubricate O-ring seal (6-10) and install into O-ring groove in the M3 hole in the outer end cap (3-80).

**3.3.23.2.2** Install the jackscrew (3-290) through the outboard side of the outer end cap (3-80).

**3.3.23.2.3** Apply a light coating of lubricant to threads of jackscrew (3-290).

**3.3.23.2.4** Screw jackscrew adapter (3-280) onto jackscrew (3-290).

**NOTE:**

The small round end of the M3 adapter will install on the jackscrew pointing to the inboard end of the jackscrew.

- 3.3.23.2.5** Position the jackscrew with the inboard end of the jackscrew located with the needle bearing thrust washer assembly (3-340) up against or near the jackscrew adapter (3-280).
- 3.3.23.2.6** Install outer end cap (3-80) over tie bars (3-20) and into cylinder (3-70).
- 3.3.23.2.7** Install tie bar nuts (3-90) onto tie bars (3-20).

**NOTE:**

Do not tighten nuts.

- 3.3.23.2.8** Install two socket cap screws (3-320) through jackscrew adapter (3-280) and tighten into the outer end cap (3-80).
- 3.3.23.2.9** Lightly lubricate O-ring seal (4-150) and install onto the outboard end of the jackscrew. Push the O-ring (4-150) down the jackscrew until it contacts the jackscrew adapter (3-280).
- 3.3.23.2.10** Install flat hex nut (3-300) onto jackscrew (3-290). Rotate the flat hex nut (3-300) until it is up against the O-ring seal (4-150).

**⚠ WARNING**

Excessive tightening could damage the seal (4-150) and prevent it from sealing properly. Nut should be hand-tight plus 1/4 to 1/2 turn.

- 3.3.23.2.11** Install outer end cap (3-80) over tie bars (3-20) and into cylinder (3-70). Continue at step 3.3.24.
- 3.3.23.3** Standard outer end cap installation. Install outer end cap (3-80) over tie bars (3-20) and into cylinder (3-70).
- 3.3.24** Install tie bar nuts (3-90) onto tie bars (3-20). Torque tighten tie bar nuts, alternately in 100 lbf•ft / N•m increments, until a final lubricated torque, as listed in the following table, has been achieved.

**Table 5. Tie Bar Nuts Required Torque Table**

Housing Model	Torque (±5 Percent)		Housing Model	Torque (±5 Percent)	
	N•m	lbf•ft		N•m	lbf•ft
FG01	163	120	FG7/FGH5	678	500
FG2	163	120	FG8/FGH7	678	500
FG3/FGH2	203	150	FG10/FGH8	1627	1200
FG4/FGH3	203	150	FG13/FGH10	2169	1600
FG5/FGH4	542	400	-	-	-

- 3.3.25** Install lockwashers (3-140) onto socket cap screws (3-130).
- 3.3.26** Install and tighten socket cap screws (3-130), with lockwashers (3-140), into outer end cap (3-80).

---

**NOTE:**

If the outer end cap (3-80) has an ES stop screw completed steps 3.3.26 through 3.3.29.

---

- 3.3.27** If not already removed, then remove hex nut (3-190) and old O-ring seal (4-100).
- 3.3.28** Install new O-ring seal (4-100) onto the ES stop screw and up against outer end cap (3-80).
- 3.3.29** Install hex nut (3-140) on to ES. After adjusting to proper position tighten ES stop screw.

---

**NOTE:**

Step 3.3.29 is not required if the power module is equipped with an ES stop screw or a M3 jackscrew.

---

- 3.3.30** If removed, using pipe dope, install pipe plug (3-120) into outer end cap (3-80).
- 3.3.31** Apply sufficient pneumatic pressure to outer end cap (3-80) pressure inlet port to move the piston to its full inboard position (next to inner end cap).
- 3.3.32** Remove pneumatic pressure from outer end cap (3-80).
- 3.3.33** Install breather assembly (12) in outer end cap (3-80).

---

**NOTE:**

Individual actuators may not have reducer bushing (14) depending on port and breather size.

---

## 3.4 FG2 and FG3 Early Model Pneumatic Power Module Reassembly

---

**NOTE:**

Early FG2 and FG3 pneumatic power modules were equipped with tie bars that had nuts on both ends of the tie bars (3-20) – double nuts.

Refer to Section 2, step 2.1.3 for the correct installation location for piston rod (3-40).

The actuator must be in the appropriate overtravel position. Confirm overtravel position by observing the guide block (1-30) is against the inner wall of housing (1-10).

---

- 3.4.1** Refer to assembly drawing sheet 2 of 2 Detail "C" in Appendix B. Install one rod wiper (4-10) into inner end cap (3-10).
- 3.4.2** Install one rod bushing (4-20) into inner end cap (3-10).
- 3.4.3** Coat one PolyPak seal (4-30) with lubricant and install, lip first, into inner end cap (3-10).

**⚠ CAUTION**

Install the PolyPak seal with energizer ring facing outboard side of inner end cap (3-10).

- 3.4.4** Install piston rod (3-40) through inner end cap (3-10).

**NOTE:**

The piston rod end with retainer grooves to be on the outboard side of inner end cap (3-10).

- 3.4.5** Apply lubricant to two sets of rod T-seal components (4-50).

**NOTE:**

The T-seal is composed of one rubber seal and two split skive-cut back-up rings.

- 3.4.5.1** Install two sets of rod T-seals (4-50) into the internal diameter seal grooves of piston (3-30).
  - 3.4.5.2** Install a back-up ring on each side of the T-seal.
  - 3.4.5.3** When installing the back-up rings, do not align the skive-cuts.
  - 3.4.5.4** If the back-up rings are too long and the rings overlap beyond the skive-cuts, then the rings must be trimmed with a razor sharp instrument.
- 3.4.6** Coat one D-ring seal (4-60) with lubricant and install into the piston external seal groove.

**NOTE:**

The flat side of the D-ring seal goes down into the seal groove.

- 3.4.7** Install piston (3-30) onto piston rod (3-40).

**NOTE:**

The cast rib side of the piston is to be facing away from the outboard side of inner end cap (3-10) or position piston (3-30) on the piston rod so that the retainer grooves are on the out board side of the piston.

- 3.4.8** Refer to assembly drawing sheet 2 of 2 Detail "D" in Appendix B. Install O-ring seal (4-70) into the seal groove in the outboard end of piston rod (3-40).
- 3.4.9** Install two split ring halves (3-50) into the outer most groove in piston rod (3-40) and retain by installing the recessed area of piston (3-30) over the two split halves (3-50).
- 3.4.10** Install two split ring halves (3-50) into the piston rod, in back of the piston and retain with retainer ring (3-60).
- 3.4.11** Coat two tie bars (3-20) with lubricant and install by carefully pushing tie bars through piston (3-30) and rod T-seal (4-50).
- 3.4.12** Install two tie bar O-ring seals (4-80) onto the inboard end of tie bars (3-20) and into the O-ring grooves provided.
- 3.4.13** Insert the tie bars through inner end cap (3-10) and screw hex nuts (3-90) onto inboard end of the tie bars.

---

**NOTE:**

Screw the tie bars through the hex nuts (3-90) until one complete thread is exposed.

---

- 3.4.14** Refer to assembly drawing sheet 2 of 2 Detail "E" in Appendix B. Install two tie bar O-ring seals (4-80) onto the outboard end of tie bars (3-20) and into the O-ring grooves provided.
- 3.4.15** Apply lubricant to one O-ring seal (4-40) and install into the outer diameter O-ring groove of outer end cap (3-80).
- 3.4.16** Apply lubricant to the bore of cylinder (3-70).

** CAUTION**

If needed, when installing the cylinder, hammer on the end of the cylinder only with a non-metallic object.

---

- 3.4.17** Install lubricated cylinder (3-70) over piston (3-30) and onto inner end cap (3-10). When installing the cylinder over the piston seal tilt cylinder 15 to 30° to piston rod.

---

**NOTE:**

If the power module is equipped with a M3 jackscrew, pre-assemble the M3 jackscrew to the outer end cap (3-80) per Section 3.6.

---

**3.4.18** Install outer end cap (3-80) over tie bars (3-20) and into cylinder (3-70).

**NOTE:**

The pressure inlet port should be positioned in the same position as recorded in Section 2.2, step 2.2.1.

**3.4.19** Install tie bar nuts (3-90) onto tie bars (3-20). Torque tighten tie bar nuts, alternately in 100 lbf•ft increments, until a final lubricated torque, as listed in the following table, has been achieved.

**Table 6. Early G2 and G3 Tie Bar Nuts Required Torque Table**

Housing Model	Torque (±5 Percent)		Housing Model	Torque (±5 Percent)	
	N•m	lbf•ft		N•m	lbf•ft
FG2	163	120	FG3	203	150

**3.4.20** Install lockwashers (3-140) onto socket cap screws (3-130).

**3.4.21** Install and tighten socket cap screws (3-130), with lockwashers (3-140), into outer end cap (3-80).

**3.4.22** Install pneumatic power module per Section 5, step 5.4.

## 3.5 Blind End Cap Module Reassembly

**NOTE:**

If the blind end cap has an M3 jackscrew or ES stop screw that has been removed from the blind end cap, then pre-assemble the M3 or ES into the blind end cap per Section 3.6 or 3.8.

**3.5.1** Install O-ring seal (6-10) into the O-ring groove in blind end cap (5-10).

**3.5.2** Install lockwashers (5-30) onto hex cap screws (5-20).

**NOTE:**

Verify that steps 3.2.14 and 3.2.15 have been completed prior to commencing with step 3.5.3.

**3.5.3** Install blind end cap (5-10) onto end of housing (1-10).

**3.5.4** Install and tighten hex cap screws (5-20) with lockwashers (5-30) through housing (1-10) and into blind end cap (5-10).

## 3.6 M3 Jackscrew Reassembly

---

**NOTE:**

This section is to be completed when the M3 jackscrew has been disassembled from the blind end cap or from the SR-M3 adapter plate (7-10).

If the thrust bearing assembly has been disassembled from the M3 jackscrew stud, then preassemble the thrust bearing assembly to the M3 jackscrew stud as per Section 3.6.5.

---

**3.6.1** FG01-M3 JACKSCREW REASSEMBLY TO M3 BLIND END CAP

**3.6.1.1** Apply a light coating of lubricant to threads of M3 assembly (5-50).

**3.6.1.2** Screw M3 adapter (5-45) onto M3 assembly (5-50).

---

**NOTE:**

The smaller round end of the M3 adapter will install on the M3 assembly pointing to the outboard end of the M3 assembly.

---

**3.6.1.3** Position the M3 assembly with the inboard end of the M3 located with the needle bearing thrust washer assembly (5-100) up against or near the M3 adapter (5-45).

**3.6.1.4** Lightly lubricate O-ring seal (6-20) and install into O-ring groove on the outboard side of the M3 adapter (5-45).

**3.6.1.5** Insert M3 assembly (5-50) through inboard side of the M3 blind end cap (5-10).

**3.6.1.6** Install the jackscrew adapter keeper (5-140) into the groove exposed on the outboard side of the M3 adapter (5-45).

**3.6.1.7** Lightly lubricate O-ring seal (6-30) and install onto the outboard end of the M3 jackscrew assembly. Push the O-ring (6-30) down the M3 until it contacts the M3 adapter (5-45).

**3.6.1.8** Install flat hex nut (5-60) onto M3 assembly (5-50). Rotate the flat hex nut (5-60) until it is up against the O-ring seal (6-30).

**3.6.2** FG2-M3 and FG3-M3 JACKSCREW REASSEMBLY TO M3 BLIND END CAP

**3.6.2.1** Lightly lubricate O-ring seal (6-10) and install into O-ring groove in the M3 hole in the blind end cap (5-10).

**3.6.2.2** Install the M3 jackscrew assembly (5-50) through the inboard side of the blind end cap (5-10).

**3.6.2.3** Apply a light coating of lubricant to threads of M3 assembly (5-50).

**3.6.2.4** Screw M3 adapter (5-45) onto M3 jackscrew assembly (5-50).

---

**NOTE:**

The small round end of the M3 adapter will install on the M3 assembly pointing to the inboard end of the M3 assembly.

---

- 3.6.2.5** Position the M3 assembly with the inboard end of the M3 located with the needle bearing thrust washer assembly (5-100) up against or near the M3 adapter (5-45).
- 3.6.2.6** Install two socket cap screws (5-120) through jackscrew adapter (5-45) and tighten into blind end cap (5-10).
- 3.6.2.7** Lightly lubricate O-ring seal (6-30) and install onto the outboard end of the M3 jackscrew assembly. Push the O-ring (6-30) down the M3 until it contacts the M3 adapter (5-45).
- 3.6.2.8** Install flat hex nut (5-60) onto M3 assembly (5-50). Rotate the flat hex nut (5-60) until it is up against the O-ring seal (6-30).
- 3.6.3** FG01-SR-M3 JACKSCREW REASSEMBLY TO M3-SR ADAPTER PLATE
  - 3.6.3.1** Apply a light coating of lubricant to the threads of jackscrew assembly (7-40).
  - 3.6.3.2** Install jackscrew adapter (7-45) onto the nonbearing end of jackscrew assembly (7-40).
  - 3.6.3.3** Install jackscrew adapter (7-45) through M3 adapter plate (7-10).
  - 3.6.3.4** Retain jackscrew adapter (7-45) with retainer ring (7-55).
- 3.6.4** FG2-M3 and FG3-SR-M3 JACKSCREW REASSEMBLY TO M3-SR ADAPTER PLATE
  - 3.6.4.1** Apply a light coating of lubricant to the threads of jackscrew assembly (7-40).
  - 3.6.4.2** Install jackscrew adapter (7-45) onto the nonbearing end of M3 assembly (7-40).
  - 3.6.4.3** Install jackscrew adapter (7-45) through adapter plate (7-10).
  - 3.6.4.4** Install two socket cap screws (7-120) through jackscrew adapter (7-45) and tighten into adapter plate (7-10).

- 3.6.5** M3 Thrust Bearing reassembly to Jackscrew assembly
- 3.6.5.1** Apply a coating of lubricant to the internal hole located on the inboard end of M3 assembly (5-40)/(7-50).
  - 3.6.5.2** Install the wire retainer ring (5-90)/(7-90) into the internal hole of M3 assembly until retainer ring opens up into its groove inside the M3 assembly.
  - 3.6.5.3** Pre-assemble the needle bearing thrust washer assembly (5-100)/(7-100) as follows:
    - 3.6.5.3.1** Apply lubricant to one thrust washer and install onto bearing retainer (5-110)/(7-110).
    - 3.6.5.3.2** Apply lubricant to needle bearing and install onto bearing retainer (7-110) and up against thrust washer installed in step 3.6.5.3.1.
    - 3.6.5.3.3** Apply lubricant to the remaining thrust washer and install onto bearing retainer (5-110)/(7-110) and up against the needle bearing installed in step 3.6.1.3.2.
  - 3.6.5.4** Install the pre-assembled needle bearing thrust washer assembly (5-100)/(7-100) into the open hole located on the inboard end of M3 assembly (5-50)/(7-40).

---

**NOTE:**

Press or push the bearing retainer (5-110)/(7-110) into the M3 assembly forcing the retainer ring (5-90)/(7-90) onto the neck of the bearing retainer (5-110)/(7-110).

---

## 3.7 M3 Handwheel or M3 Hex Drive Hub Installation

- 3.7.1** M3 Handwheel or Hex Drive Hub installation to M3 Jackscrew
- 3.7.1.1** Install handwheel or hex drive hub (10-10) onto M3 jackscrew (7-40).
  - 3.7.1.2** Install two grooved pins (10-20) and (10-30) through handwheel hub or hex drive hub (10-10) and through M3 jackscrew (7-40).
- 3.7.2** Early model FG2 and FG3 M3 Handwheel and Hex Nut installation
- 3.7.2.1** Screw the slotted nut onto the outboard end of the M3 jackscrew with the slot facing toward the cylinder end cap. Screw the nut until one of the slots in the nut is aligned with the cross drilled "through hole" in the stud.

**⚠ CAUTION**

When aligning the slot and the cross drilled hole, make certain that the back of the slot is at least one thread from being aligned with the hole.

- 3.7.2.2** Insert the spiral pin through the slotted nut and through the jackscrew stud making sure that equal amounts of the spiral pin is exposed on both sides of the slotted nut and the jackscrew stud.
- 3.7.2.3** For actuators equipped with a M3 jackscrew and require an optional handwheel, install handwheel using the following procedure:
  - 3.7.2.3.1** Place the handwheel onto M3 jackscrew and over the pinned slotted nut.

**NOTE:**

The hub of handwheel has a cast hexagon hole that fits over the pinned slotted nut.

- 3.7.2.3.2** Place lockwasher onto M3 jackscrew up against handwheel hub.
- 3.7.2.3.3** Install and tighten hex nut onto M3 jackscrew and screw nut up against the lockwasher.

## 3.8 Extended Stop Blind End Cap Reassembly

- 3.8.1** Apply a light coating of lubricant to the threads of ES stop screw (5-50).
- 3.8.2** Install hex nut (5-60) onto the ES stop screw (5-50).
- 3.8.3** Install ES stop screw (5-50) through ES blind end cap (5-10).

## 3.9 Actuator Testing

- 3.9.1** Leakage Test: All areas where leakage to atmosphere may occur are to be checked, using a commercial leak testing solution.

**⚠ CAUTION**

Pressure applied to the actuator is not to exceed the maximum operating pressure rating listed on the actuator name tag. Test the actuator using a properly adjusted self relieving regulator with gauge.

- 3.9.2** Cycle the actuator five times at the Nominal Operating Pressure (NOP) as listed on the actuator name tag or the customer's normal actuator supply pressure. If excessive leakage across the pistons is noted, generally a bubble which breaks three seconds or less after starting to form, cycle the actuator five times as this will allow the seals to seek their proper service condition.
- 3.9.3** Apply NOP pressure to the pressure port in inner end cap (3-10) and allow the actuator to stabilize.

- 3.9.4** Apply a commercial leak testing solution to the following areas:
- 3.9.4.1** Joint between inner end cap (3-10) and cylinder (3-70). This checks cylinder to inner end cap O-ring seal.
  - 3.9.4.2** The port hole in the outer end cap (3-80). This checks the piston D-seal to cylinder (3-70), O-ring seal (4-70) and rod T seal (4-50).

---

**NOTE:**

If excessive leakage across the piston remains, the actuator must be disassembled and the cause of leakage must be determined and corrected.

---

- 3.9.4.3** The vent check port hole in housing. This checks the PolyPak seal (4-30) that seals piston rod (3-40) to inner end cap (3-10).
  - 3.9.4.4** Remove pressure from the pressure inlet port.
- 3.9.5** If an actuator was disassembled and repaired, the above leakage test must be performed again.
- 3.9.6** Shell Pressure Test: An optional pressure test can be performed on a PED certified actuator by applying pressure to both sides of the piston simultaneously for a period of two (2) minutes. If any leakage occurs across a static seal, the unit must be disassembled and the cause of leakage determined and corrected.

 **WARNING**

The actuators main pressure bearing parts will be tested in controlled conditions in accordance with the requirement of PED by pressuring both sides of the piston to avoid damage and over torquing of the actuator components. If further future testing in the field is necessary, Biffi should be contacted for guidance.

---

## Section 4: Field Conversions

### 4.1 Fail Mode Reversal (CW to CCW, or CCW to CW) for G and GH Only

---

**NOTE:**

FGC/GHC actuators must not undergo fail mode reversal without specific knowledge and acceptance of the resulting torque output. If a symmetrical yoke is being used during the process, then fail mode reversal will not affect the torque output.

---

- 4.1.1 Remove spring module per Section 5.1.
- 4.1.2 Remove pneumatic power module per Section 5.3.
- 4.1.3 Reinstall the spring module onto the opposite end of housing (1-10), as it was previously located per Section 5.2.
- 4.1.4 Reinstall the pneumatic power module onto the opposite end of housing (1-10) as it was previously located per Section 5.4.

### 4.2 Converting Double-Acting Actuator to Spring-Return

- 4.2.1 Remove the blind end cap module per Section 2.4.
- 4.2.2 If pneumatic power module needs to be relocated due to fail mode requirements (fail counterclockwise), use Section 5.3 for removal and Section 5.4 for installation.

---

**NOTE:**

Skip step 4.2.3 when working on FG01-SR models and continue at step 4.2.4.

---

- 4.2.3 Install the SR Powr-Swivl module per Section 5.6.
- 4.2.4 Install the spring module per Section 5.2.

### 4.3 Converting Spring-Return Actuator to Double-Acting

- 4.3.1 Remove the spring cartridge per Section 5.1.
- 4.3.2 If pneumatic power module needs to be relocated due to fail mode requirements (fail counterclockwise), use Section 5.3 for removal and Section 5.4 for installation.

---

**NOTE:**

Skip step 4.3.3 when working on FG01-SR models and continue at step 4.3.4.

---

**4.3.3** Remove the spring cartridge Powr-Swivl module per Section 5.5.

**4.3.4** Install the blind end cap module per Section 3.5.

## 4.4 Add an M3 Jackscrew to Blind End Cap Module

**4.4.1** Remove blind end cap module per Section 2.4.

**4.4.2** If new M3 blind end cap module is not pre-assembled with the M3 then assembly M3 to the blind end cap (5-10) per Section 3.6, step 3.6.1 or 3.6.2.

**4.4.3** Install the assembled M3 blind end cap module per Section 3.5.

**4.4.4** To install the M3 Handwheel or M3 drive hub, refer to Section 3.7.

## 4.5 Add an M3 Jackscrew to Power Module Outer End Cap

**4.5.1** Remove outer end cap (3-80) per Section 2.2, steps 2.2.5 and 2.2.6.

**4.5.2** If new M3 outer end cap (3-80) is not pre-assembled with the M3 then assembly M3 to the outer end cap (3-80) per Section 3.3, step 3.3.22.1 or 3.3.22.2.

**4.5.3** Install the assembled M3 outer end cap (3-80) per Section 3.3, step 3.3.23.1.11 or 3.3.22.2.11 and 3.3.24 through 3.3.26.

**4.5.4** To install the M3 Handwheel or M3 drive hub refer to Section 3.7.

## 4.6 Add an M3 Jackscrew to Spring Module

**4.6.1** Remove FG-SR (7-10) adapter plate per Section 5.1, steps 5.1.2 and 5.1.3.

**4.6.2** If new M3 FG-SR adapter plate (7-10) is not pre-assembled with the M3 then assembly M3 to the FG-SR cover plate (7-10) per Section 3, step 3.6.3 or 3.6.4.

**4.6.3** Install the assembled M3 adapter plate (7-10) onto the spring cartridge out end per Section 5.2, steps 5.2.11 through 5.2.15.

**4.6.4** To install the M3 Handwheel or M3 drive hub, refer to Section 3.7.

## 4.7 Add an Extended Stop (ES) to Blind End Cap Module

**4.7.1** Remove blind end cap module per Section 2.4.

**4.7.2** If new ES blind end cap module is not preassembled with the ES then assembly ES to the blind end cap per Section 3.8.

**4.7.3** Install the assembled ES blind end module per Section 3.5.

## 4.8 Add an Extended Stop (ES) to Power Module Outer End Cap

- 4.8.1** Remove outer end cap per Section 2.2, steps 2.2.5 and 2.2.6.
- 4.8.2** If new ES outer end cap is not pre-assembled with the ES then assembly ES to the end cap per Section 3.8.
- 4.8.3** Install the assembled ES outer end (3-80) per Section 3.3, steps 3.3.22.3, 3.3.24 through 3.3.26.

## 4.9 Add an Extended Stop (ES) to Spring Module

- 4.9.1** Remove FG-SR (7-10) adapter plate per Section 5.1, steps 5.1.2 and 5.1.3.
- 4.9.2** If new ES FG-SR adapter plate (7-10) is not pre-assembled with the ES then assembly ES to the FG-SR cover plate as follows:
  - 4.9.2.1** Install ES stud (7-40) into adapter plate (7-10).
  - 4.9.2.2** Install O-ring seal (6-30) onto outboard end of ES (7-40) and up against outboard side of adapter plate (7-10).
  - 4.9.2.3** Install stop screw nut (7-50) onto outboard end of ES (7-40).
- 4.9.3** Install the assembled ES adapter plate (7-10) onto the spring cartridge out end per Section 5.2, steps 5.2.11 through 5.2.15.

# Section 5: Module Removal and Installation

---

**NOTE:**

When the spring module is to be removed, it should be removed from the drive module prior to the pneumatic power module removal or disassembly.

---

**⚠ WARNING**

Do not remove spring module while spring is compressed.

---

**⚠ WARNING**

Actuators equipped with a spring cartridge mounted M3 jackscrew or an extended stop (ES) read warning tag wired to the spring cartridge cover plate.

---

## 5.1 Spring Module Removal

**⚠ WARNING**

Do not remove spring module while spring is compressed.

---

**NOTE:**

Review Section 2.1 - General Disassembly before proceeding with Spring Module Disassembly.

---

**NOTE:**

The setting of stop screws (1-180) should be checked and setting recorded before stop screws are loosened or removed.

---

**NOTE:**

FG2-SRF and FG3-SRF use step 5.1.1. FG01-SR, FG2-SR, FG3-SR through FG13, skip step 5.1.1 and start at step 5.1.2.

---

- 5.1.1** For FG2-SRF and FG3-SRF only, unscrew and remove pipe plug (7-10) from spring cartridge assembly (5-10). Skip steps 5.1.2, 5.1.3, and start at step 5.1.4.

**⚠ WARNING**

If an M3, M3HW jackscrew or extended stop (ES) is mounted in the spring module cover plate (7-10), the M3, M3HW or ES should not contact the end of the spring module tension rod.

- 5.1.2** Unscrew hex cap screws (7-20) with lockwashers (7-30) from cover plate (7-10), or if spring module has a M3-SR adapter plate (7-10) or a SR-ES adapter plate, remove safety wire from hex cap screws (7-20) and then remove hex cap screws (7-20).
- 5.1.3** Remove the cover plate (7-10) from spring cartridge assembly (5-10).
- 5.1.4** Apply pneumatic pressure to inner end cap (2-40) port "A" to compress the spring enough to move the yoke off the stop screw on the spring module side of the drive module.
- 5.1.5** Loosen the stop screw nut (1-190) located on the stop screw that is closest to or next to spring module.
- 5.1.6** Unscrew stop screw (1-180) that is closest to or next to spring module (unscrew or back out until the load is removed from the stop screw).
- 5.1.7** Remove pneumatic pressure from pressure inlet port of inner end cap (3-10).

**⚠ CAUTION**

Due to the weight and size of spring cartridge assembly (5-10), heavy duty support equipment will be required when removing spring cartridge assembly from the actuator housing. Refer to Section 6 for spring cartridge module weights.

- 5.1.8** The spring cartridge "pre-load" must be removed before spring cartridge assembly (5-10) is removed from housing (1-10). Refer to steps 5.1.4 through 5.1.6 for spring cartridge "pre-load" removal.
- 5.1.9** Remove breather assembly (12) from outer end cap (3-80) port "B".

**⚠ CAUTION**

The maximum pressure to be applied in step 5.1.10 is 25 psig.

- 5.1.10** Apply pneumatic pressure, not to exceed the maximum as indicated in the above "CAUTION", to the pressure inlet port "B" of outer end cap (3-80) to move the spring cartridge tension rod hex nut out of its cast hex seat.

**NOTE:**

If pneumatic pressure is not available to apply to the pressure inlet port "B" located in outer end cap (3-80) then remove pipe plug (3-120) or if equipped with an extended stop (ES) remove the ES. Using a long rod go through the outer end cap pipe plug or ES vacant port hole and push on the piston rod so as to move the spring cartridge tension rod hex nut out of its cast hex seat.

- 5.1.11 Unscrew the spring cartridge tension rod from the drive module. The tension rod can be rotated for removal by going through the open end of spring cartridge assembly with a square male drive extension.
- 5.1.12 Remove hex cap screws (5-20) with lockwashers (5-30) from housing (1-10).
- 5.1.13 Remove spring cartridge assembly (5-10) from actuator housing (1-10).

### **WARNING**

Under no circumstances should the spring cartridge assembly (5-10) be cut apart, as the spring is pre-loaded and the spring cartridge is a weld assembly.

## 5.2 Spring Module Installation

### **CAUTION**

Due to the weight and size of spring module, heavy duty support equipment will be required when installing spring cartridge module to the actuator housing. For the approximate weight of the spring cartridge refer to Section 6.

### **WARNING**

Actuator must be in the appropriate overtravel position (Refer to detail "A" on warning tag attached to spring module access hole cover or to Biffi drawing part number 130084 for FG01 models or part number 123650 for FG2 through FG13 models). Confirm overtravel position by observing the guide block (1-30) is against the inner wall of housing (1-10).

### **NOTE:**

The setting of stop screws (1-180) should be checked and setting recorded before stop screws are loosened or removed.

- 5.2.1 On stop screw (1-180) that is located on the same side of the housing as spring cartridge (5-10), loosen stop screw nut (1-190).
- 5.2.2 Unscrew or back out stop screw (1-180) to achieve overtravel as illustrated in detail "A" on warning tag attached to spring module cover plate or to Biffi drawing part number 123650.
- 5.2.3 Install O-ring seal (6-20) into the O-ring groove in the inboard end of spring cartridge assembly (5-10).
- 5.2.4 Using lifting equipment move spring module up to housing (1-10) and align spring cartridge tension rod with extension rod assembly (9-50) for FG2 through FG13 models or FG01 models align spring cartridge with tapped hole in guide block (1-30).

**⚠ WARNING**

Complete step 5.2.5 to avoid severe injury to personnel or incur major damage to the actuator.

**5.2.5** Spring cartridge tension rod to rod extension installation

**5.2.5.1** Using a male square drive extension, go through the open end of spring module (5-10) and rotate the tension rod nut until initial thread engagement is achieved.

**NOTE:**

Confirm initial thread engagement of rod extension (9-50) to tension rod, or for FGH/FGHC models, confirm initial thread engagement of tension rod to guide block.

**5.2.5.2** After confirming initial thread engagement, rotate tension rod into extension rod assembly (9-50) per the following table.

**⚠ WARNING**

After initial thread engagement, the tension rod must be rotated clockwise the minimum number of turns listed in the following table.

**Table 7. Tension Rod Number of Turns Table**

Actuator Model FG/FGC/FGH/FGHC	Minimum Number of Turns
1	6
2	10
3	10
4	10
5	13
7	14
8	20
10	25
FG13	31

**⚠ WARNING**

When screwing tension rod into extension rod assembly (9-50) make certain that the tension rod and extension rod assembly threads do not cross-thread.

**5.2.6** Torque tighten the spring cartridge tension rod as listed in the following table.

**Table 8. Spring Cartridge Tension Rod Torque Table**

Housing Model FG/FGC/FGH/FGHC	Torque (±5 Percent)		Housing Model FG/FGC/FGH/FGHC	Torque (±5 Percent)	
	N•m	lbf•ft		N•m	lbf•ft
FG01	68	50	7	325	240
2	122	90	8	325	240
3	122	90	10	325	240
4	325	240	FG13	325	240
5	325	240	-	-	-

**5.2.7** Install lock washers (5-30) onto hex cap screws (5-20).

**5.2.8** Install hex cap screws (5-20) with lockwashers (5-30) through housing (1-10) and into spring cartridge assembly (5-10) and tighten.

**5.2.9** Install O-ring seal (6-10) into the O-ring groove in the outboard end of spring cartridge assembly (5-10).

**NOTE:**

FG2-SRF and FG3-SRF use step 5.2.10. For FG01-SR, FG2-SR, FG3-SR through FG13-SR, skip step 5.2.10 and start at step 5.2.11.

**5.2.10** Using pipe sealant on the threads, install pipe plug (7-10) in the vacant hole in outboard end of spring cartridge assembly (5-10). Skip steps 5.2.11 through 5.2.13 and start at step 5.2.14.

**5.2.11** Install lockwashers (7-30) onto hex cap screws (7-20).

**5.2.12** Install the cover plate (7-10) or install M3 adapter plate (7-10) onto the outboard end of spring cartridge assembly (5-10).

**5.2.13** Install and tighten hex cap screws (7-20) with lockwashers (7-30) through cover plate (7-10) and into spring cartridge assembly (5-10).

**5.2.14** Torque tighten hex cap screws (7-20) until a final lubricated torque, as listed in the following table, has been achieved.

**Table 10. Hex Cap Screws (7-20) Torque Table**

Housing Model FG/FGC/FGH/FGHC	Torque (±5 Percent)		Housing Model FG/FGC/FGH/FGHC	Torque (±5 Percent)	
	N•m	lbf•ft		N•m	lbf•ft
FG01	41	30	7	183	135
2	41	30	8	325	240
3	41	30	10	386	285
4	88	65	FG13	461	340
5	88	65	-	-	-

**5.2.15** On M3, M3HW and ES models install Monel wire (6-130) through each hex cap screw (7-20) per the following steps:

**NOTE:**

The following steps provide guidelines for wire locking hex cap screws to discourage screw loosening and removal in applications where screw removal could be hazardous.

- 5.2.15.1** Make sure hex cap screws are tightened to their specified torque.
- 5.2.15.2** Using required lengths of 0.31 diameter Monel wire as provided in the module ordered. When replacing Monel wire, use Table 10 for wire length requirements.

**Table 9. Wire Length Requirements**

Model FG/FGC/FGH/FGHC	Length		Model FG/FGC/FGH/FGHC	Length	
	mm	in.		mm	in.
FG01-SR	914.4	36	5-SR	1676.4	66
2-SR	1117.6	44	7-SR	2006.6	79
3-SR	1219.2	48	8-SR	2235.2	88
4-SR	1397.0	55	FG10-SR	2794.0	110

- 5.2.15.3** Twist the end of both wires together and insert one through the drilled hole in the hex cap screw head. Pass the second wire over the screw head and twist it three (3) times around the first wire at a location where the first wire exits the screw head.
- 5.2.15.4** Repeat the procedure until the second wire is twist tied to the screw head through wire of the last screw head.
- 5.2.15.5** Attach caution tag and twist tie the wires from the last screw head to the twisted wires of the first screw head. See Figure 1 for illustration.

**Figure 1. Tag Attachment Guide**

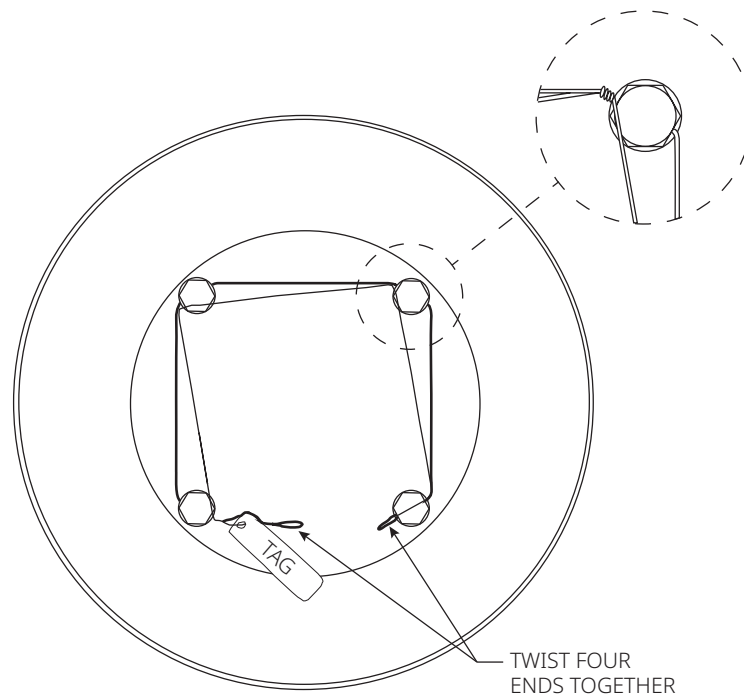

- 5.2.16** If removed install stop screw nuts (1-190) onto stop screws (1-180).
- 5.2.17** If removed install O-ring (2-90) onto stop screws (1-180).
- 5.2.18** If removed install two stop screws (1-180) into two stop screw holes on the front of housing (1-10).
- 5.2.19** Adjust both stop screws (1-180) back to settings recorded earlier in Section 5.
- 5.2.20** Tighten both stop screw nuts (1-190) securely.

## 5.3 Pneumatic Power Module Removal

### CAUTION

Due to the weight and size of spring module, heavy duty support equipment will be required when installing spring cartridge module to the actuator housing. For the approximate weight of the spring cartridge refer to Section 6.

- 5.3.1** For standard outer end cap with pipe plug, use step 5.3.1.1. For outer end cap with extended stop (ES), use step 5.3.1.2. For FG2 or FG3 outer end cap with M3 or M3HW, use step 5.3.1.3. For FG01 outer end cap with M3 or M3HW, use step 5.3.1.4.
  - 5.3.1.1** STANDARD OUTER END CAP: Remove pipe plug (3-120) from outer end cap (3-80).
  - 5.3.1.2** ES OUTER END CAP
    - 5.3.1.2.1** Loosen ES nut (3-190).
    - 5.3.1.2.2** Unscrew ES (3-180) and remove from outer end cap (3-80).
  - 5.3.1.3** FG2 OR FG3 M3/M3HW OUTER END CAP
    - 5.3.1.3.1** Remove socket cap screws (3-320) from M3 adapter (3-280).
    - 5.3.1.3.2** Remove M3 adapter (3-280) from outer end cap (3-80).
  - 5.3.1.4** FG01M3/M3HW OUTER END CAP
    - 5.3.1.4.1** Remove socket cap screw (3-130) from M3 keeper (3-360).
    - 5.3.1.4.2** Remove M3 keeper (3-360) from M3 adapter (3-360) and outer end cap (3-80).
    - 5.3.1.4.3** Remove M3 jackscrew (3-290) with M3 adapter (3-360) from outer end cap (3-80).
- 5.3.2** Using a male square drive extension, go through outer end cap (3-80) and unscrew piston rod (3-40) from the drive module.
- 5.3.3** Remove hex cap screws (3-100) with lockwashers (3-110) from housing (1-10).

---

#### NOTE:

When removing power module from housing (1-10), be careful not to lose O-ring seal (4-90).

---

- 5.3.4** Remove power module from actuator housing (1-10).

## 5.4 Pneumatic Power Module Installation

- 5.4.1 Check to verify that O-ring seal (4-90) is properly seated in its seal groove located on the housing side of inner end cap (3-10).

---

**NOTE:**

FG2 and FG3 models (older models) confirm that the two inboard hex nuts (3-90) flats are aligned to fit into the slot located in the end of housing (1-10).

---

- 5.4.2 Using lifting equipment move the power module up to the drive module and align piston rod (3-40) as follows:
  - 5.4.2.1 For FG2 through FG13 models, align piston rod (3-40) with power module extension rod assembly (1-50).
  - 5.4.2.2 For FG01 models, align piston rod (3-40) with the drive module guide block (1-30).
- 5.4.3 Using a male square drive extension, go through outer end cap (3-80) and install piston rod (3-40) as follows:

**⚠ WARNING**

After initial thread engagement, the tension rod must be rotated clockwise the minimum number of turns listed in the following table.

---

**Table 11. Piston Rod/Tension Rod Number of Turns Table**

Actuator Model FG/FGC/FGH/FGHC	Minimum Number of Turns
1	6
2	10
3	10
4	10
5	13
7	14
8	20
10	25
FG13	31

- 5.4.3.1 For FG2 through FG13, screw piston rod (3-40) onto extension rod assembly (1-50). FGH/FGHC2 through FGH/FGHC10, screw piston rod (3-40) directly into guide block (1-30).
- 5.4.3.2 For FG01 only, screw piston rod (3-40) onto guide block (1-30).

**⚠ CAUTION**

When screwing piston rod into the FG2 through FG13, extension rod assembly (1-50) and FG/FGC/FGH/FGHC piston rod into guide block (1-30) or FG01 guide block (1-30), make certain that the piston rod and extension rod assembly/guide block threads do not cross-thread.

- 5.4.4 Torque tighten piston rod (3-40). Refer to Section 3, step 3.3.2 for correct torque value.

**Table 12. Spring Cartridge Tension Rod Torque Table**

Housing Model FG/FGC/FGH/FGHC	Torque (±5 Percent)		Housing Model FG/FGC/FGH/FGHC	Torque (±5 Percent)	
	lbf•ft	N•m		lbf•ft	N•m
FG01	90	122	7	240	325
2	90	122	8	240	325
3	90	122	10	240	325
4	240	325	FG13	240	325
5	240	325	-	-	-

- 5.4.5 Install lock washers (3-110) onto hex cap screws (3-100).
- 5.4.6 Install hex cap screws (3-100) with lockwashers (3-110) through housing (1-10) and screw into inner end cap (3-10).
- 5.4.7 For standard outer end cap with pipe plug, use step 5.4.7.1. For outer end cap with extended stop (ES), use step 5.4.7.2. For FG2 or FG3 outer end cap with M3 or M3HW, use step 5.4.7.3. For FG01 outer end cap with M3 or M3HW, use step 5.4.7.4.
  - 5.4.7.1 Standard outer cap: Using pipe dope, install pipe plug (3-120) into outer end cap (3-80).
  - 5.4.7.2 ES outer end cap
    - 5.4.7.2.1 Screw ES (3-180) into outer end cap (3-80).
    - 5.4.7.2.2 Install ES nut (3-190) on to ES (3-180).
  - 5.4.7.3 FG2 or FG3 M3/M3HW outer end cap
    - 5.4.7.3.1 Install M3 adapter (3-280) into outer end cap (3-80).
    - 5.4.7.3.2 Install socket cap screws (3-320) through M3 adapter (3-280) and into outer end cap (3-80).
  - 5.4.7.4 FG01 M3/M3HW outer end cap
    - 5.4.7.4.1 Remove socket cap screw (3-130) from M3 keeper (3-360).
    - 5.4.7.4.2 Remove M3 keeper (3-360) from M3 adapter (3-360) and outer end cap (3-80).
    - 5.4.7.4.3 Remove M3 jackscrew (3-290) with M3 adapter (3-360) from outer end cap (3-80).

## 5.5 FG2 Through FG13 Powr-Swivl Removal (Excludes FGH/FGHC Model Actuators)

### CAUTION

While step 5.5.1 is in progress, be sure to maintain guide bar retention when moving the guide block.

- 5.5.1** Push the guide block to the side of housing (1-10) that will expose the extension rod assembly (1-50).

### NOTE:

The guide block can be moved by inserting a long non-metallic rod through the hole where the blind end cap was removed and pushing on the guide block.

- 5.5.2** Refer to assembly drawing sheet 2 of 2 Detail "B" in Appendix B. Use Biffi tool part number as listed in chart in Section 1, step 1.2.1 to remove retainer nut assembly (1-60) from the guide block (1-30).

### CAUTION

When removing rod extension assembly from guide block, be careful not to drop one of the spherical washers inside the housing.

- 5.5.3** Remove rod extension assembly (1-50) from guide block (1-30).

### NOTE:

One spherical washer (1-40) will be removed from guide block (1-30) when extension rod assembly is removed.

- 5.5.4** Remove the remaining spherical washer (1-40) from guide block (1-30).

## 5.6 FG2 Through FG13 Powr-Swivl Module Installation (Excludes FGH/FGHC Model Actuators)

### WARNING

The actuator must be in the appropriate overtravel position. Confirm overtravel position by observing the guide block (1-30) is against the inner wall of housing (1-10).

### CAUTION

While step 5.6.1 is in progress, be sure to maintain guide bar retention when moving the guide block.

**5.6.1** Push the guide block to the required side of the housing (1-10).

#### NOTE:

The guide block can be moved by inserting a long rod through either end of the housing and pushing on the guide block.

**5.6.2** Lubricate two spherical washers (1-40) and one extension rod assembly (1-50).

**5.6.3** Install one spherical washer (1-40) into the side of guide block (1-30).

#### NOTE:

The spherical side of washer (1-40) will be facing to the outside of guide block (1-30).

**5.6.4** Install second spherical washer (1-40) over threaded end of extension rod assembly (1-50).

#### NOTE:

The spherical side of the washer will go on the extension rod assembly facing the head of the extension rod assembly.

**5.6.5** Install extension rod assembly (1-50) into right of guide block (1-30) and up against the first spherical washer (1-40).

**5.6.6** Install extension retainer nut assembly (1-60) over extension rod assembly (1-50) and screw into guide block (1-30).

**5.6.7** Tighten extension retainer nut assembly (1-60) until extension rod assembly (1-50) cannot move. Back off the extension retainer nut assembly (1-60) just enough to allow for extension rod assembly (1-50) to move freely.

# Section 6: Actuator Support Information

## 6.1 FG/FGC/FGH/FGHC Module Weights by Item Number and Actuator Housing Size

**Table 13. FG/FGC/FGH/FGHC Module Weights by Item Number and Actuator Housing Size (1)**

Item Number		FG01 Weight	2 Weight	3 Weight	4 Weight	5 Weight	7 Weight	8 Weight	10 Weight	FG13 Weight	Module Description
1	lb	83	110	162	280	545	1025	1495	2550	4625	Drive Module
	kg	38	50	73	127	247	465	678	1157	2098	
3	lb	69	N/A	N/A	N/A	N/A	N/A	N/A	N/A	N/A	8 in. Diameter Power Module
	kg	31	N/A	N/A	N/A	N/A	N/A	N/A	N/A	N/A	
3	lb	68	80	N/A	N/A	N/A	N/A	N/A	N/A	N/A	9 in. Diameter Power Module
	kg	31	36	N/A	N/A	N/A	N/A	N/A	N/A	N/A	
3	lb	75	74	88	N/A	N/A	N/A	N/A	N/A	N/A	10 in. Diameter Power Module
	kg	34	33	40	N/A	N/A	N/A	N/A	N/A	N/A	
3	lb	86	86	104	130	N/A	N/A	N/A	N/A	N/A	12 in. Diameter Power Module
	kg	39	39	47	59	N/A	N/A	N/A	N/A	N/A	
3	lb	96	96	114	145	N/A	N/A	N/A	N/A	N/A	14 in. Diameter Power Module
	kg	44	44	51	66	N/A	N/A	N/A	N/A	N/A	
3	lb	N/A	135	145	168	295	N/A	N/A	N/A	N/A	16 in. Diameter Power Module
	kg	N/A	61	66	76	134	N/A	N/A	N/A	N/A	
3	lb	N/A	N/A	235	260	305	585	N/A	N/A	N/A	20 in. Diameter Power Module
	kg	N/A	N/A	107	118	138	265	N/A	N/A	N/A	
3	lb	N/A	N/A	N/A	340	410	735	911	N/A	N/A	24 in. Diameter Power Module
	kg	N/A	N/A	N/A	154	186	334	413	N/A	N/A	
3	lb	N/A	N/A	N/A	505	590	810	1225	1120	N/A	28 in. Diameter Power Module
	kg	N/A	N/A	N/A	229	268	367	556	508	N/A	
3	lb	N/A	N/A	N/A	N/A	977	1100	1260	1440	N/A	32 in. Diameter Power Module
	kg	N/A	N/A	N/A	N/A	443	499	572	653	N/A	
3	lb	N/A	N/A	N/A	N/A	1243	1400	1525	1755	N/A	36 in. Diameter Power Module
	kg	N/A	N/A	N/A	N/A	564	653	692	796	N/A	
3	lb	N/A	N/A	N/A	N/A	N/A	N/A	1975	2205	-	40 in. Diameter Power Module
	kg	N/A	N/A	N/A	N/A	N/A	N/A	896	1000	-	
3	lb	N/A	N/A	N/A	N/A	N/A	N/A	N/A	N/A	3120	44 in. Diameter Power Module
	kg	N/A	N/A	N/A	N/A	N/A	N/A	N/A	N/A	1415	
3	lb	N/A	N/A	N/A	N/A	N/A	N/A	N/A	N/A	-	48 in. Diameter Power Module
	kg	N/A	N/A	N/A	N/A	N/A	N/A	N/A	N/A	-	
3	lb	N/A	N/A	N/A	N/A	N/A	N/A	N/A	N/A	4130	52 in. Diameter Power Module
	kg	N/A	N/A	N/A	N/A	N/A	N/A	N/A	N/A	1873	
5	lb	160	225	320	564	975	2740	3545	4975	10010	SR1 Spring Module
	kg	73	102	145	256	442	1243	1608	2257	4541	
5	lb	158	215	310	549	980	2630	2345	4515	9275	SR2 Spring Module
	kg	72	98	141	249	445	1193	1064	2048	4207	

**Table 14. FG/FGC/FGH/FGHC Module Weights by Item Number and Actuator Housing Size (2)**

Item Number		FG01 Weight	2 Weight	3 Weight	4 Weight	5 Weight	7 Weight	8 Weight	10 Weight	FG13 Weight	Module Description
5	lb	153	215	295	534	925	2410	3085	4095	8060	SR3 Spring Module
	kg	69	98	134	242	420	1093	1399	1858	3656	
5	lb	144	200	280	474	860	2210	N/A	3735	7325	SR4 Spring Module
	kg	65	91	127	215	390	1002	N/A	1694	3323	
5	lb	N/A	200	N/A	N/A	N/A	N/A	N/A	N/A	N/A	SRA5 Spring Module
	kg	N/A	91	N/A	N/A	N/A	N/A	N/A	N/A	N/A	
5	lb	N/A	180	N/A	N/A	N/A	N/A	N/A	N/A	N/A	SRA6 Spring Module
	kg	N/A	82	N/A	N/A	N/A	N/A	N/A	N/A	N/A	
5	lb	N/A	220	310	N/A	N/A	N/A	N/A	N/A	N/A	SRF1 Spring Module
	kg	N/A	100	141	N/A	N/A	N/A	N/A	N/A	N/A	
5	lb	N/A	210	300	N/A	N/A	N/A	N/A	N/A	N/A	SRF2 Spring Module
	kg	N/A	95	136	N/A	N/A	N/A	N/A	N/A	N/A	
5	lb	N/A	210	285	N/A	N/A	N/A	N/A	N/A	N/A	SRF3 Spring Module
	kg	N/A	95	129	N/A	N/A	N/A	N/A	N/A	N/A	
5	lb	N/A	195	270	N/A	N/A	N/A	N/A	N/A	N/A	SRF4 Spring Module
	kg	N/A	88	122	N/A	N/A	N/A	N/A	N/A	N/A	
5	lb	N/A	205	N/A	N/A	N/A	N/A	N/A	N/A	N/A	SRF5 Spring Module
	kg	N/A	93	N/A	N/A	N/A	N/A	N/A	N/A	N/A	
5	lb	N/A	185	N/A	N/A	N/A	N/A	N/A	N/A	N/A	SRF6 Spring Module
	kg	N/A	84	N/A	N/A	N/A	N/A	N/A	N/A	N/A	

## 6.2 FG01 Tool Style and Wrench Size

**Table 15. FG01 Tool Style and Wrench Size**

Item Number	Wrench Size	Item Quantity	Location or Description	Recommended Tool Style
1-110	9/16 in.	4	Hex Cap Screws	Socket
1-160	1/2 in.	4	Hex Cap Screws	Socket
1-180	3/8 sq. in.	2	Stop Screws	Open End or Adjustable
1-190	1-15/16 in.	2	Hex Jam Nuts	Open End or Adjustable
3-20	3/8 in.	2	Tie Bar (flats)	Open End or Adjustable
3-40	3/8 sq. in.	1	Piston Rod	Male Drive Extension
3-90	1-1/8 in.	2	Standard Hex Nuts	Socket
3-100	9/16 in.	4	Hex Cap Screws	Socket
3-120	5/8 sq. in.	1	Pipe Plug	Open End or Adjustable
3-130	3/16 in.	2	Socket Cap Screws	Allen
5-20	9/16 in.	4	Hex Cap Screws	Socket
7-20	9/16 in.	4	Hex Cap Screws	Socket
12	1 in.	1	Breather Assembly	Socket
13	3/4 in.	2	Vent Check Assembly	Open End
-	3/8 sq. in.	1	Tension rod	Male Drive Extension

## 6.3 FG/FGC2 Tool Style and Wrench Size

**Table 16. FG/FGC2 Tool Style and Wrench Size**

Item Number	Wrench Size	Item Quantity	Location or Description	Recommended Tool Style
1-110	9/16 in.	6	Hex Cap Screws	Socket
1-160	9/16 in.	4	Hex Cap Screws	Socket
1-180	3/8 sq. in.	2	Stop Screws	Open End or Adjustable
1-190	1-1/8 in.	2	Hex Jam Nuts	Open End or Adjustable
3-20	3/8 in.	2	Tie Bar (flats)	Open End or Adjustable
3-40	3/8 sq. in.	1	Piston Rod	Male Drive Extension
3-90	1-1/8 in.	2	Standard Hex Nuts	Socket
3-100	9/16 in.	4	Hex Cap Screws	Socket
3-120	5/8 sq. in.	1	Pipe Plug	Open End or Adjustable
3-130	3/16 in.	2	Socket Cap Screws	Allen
5-20	9/16 in.	6	Hex Cap Screws	Socket
7-20	9/16 in.	4	Hex Cap Screws	Socket
12	1 in.	1	Breather Assembly	Socket
13	3/4 in.	2	Vent Check Assembly	Open End
-	3/8 sq. in.	1	Tension rod	Male Drive Extension

## 6.4 FG/FGC3 Tool Style and Wrench Size FGH2/FGHC2 for Item Number 3-20 to 3-130

**Table 17. FG/FGC3 Tool Style and Wrench Size, FGH2/FGHC2 for Item Number 3-20 to 3-130**

Item Number	Wrench Size	Item Quantity	Location or Description	Recommended Tool Style
1-110	9/16 in.	8	Hex Cap Screws	Socket
1-160	9/16 in.	4	Hex Cap Screws	Socket
1-180	1/2 sq. in.	2	Stop Screws	Open End or Adjustable
1-190	1-5/16 in.	2	Hex Jam Nuts	Open End or Adjustable
3-20	1/2 in.	2	Tie Bar (flats)	Open End or Adjustable
3-40	3/8 sq. in.	1	Piston Rod	Male Drive Extension
3-90	1-5/16 in.	4	Standard Hex Nuts	Socket
3-100	9/16 in.	6	Hex Cap Screws	Socket
3-120	5/8 sq. in.	1	Pipe Plug	Open End or Adjustable
3-130	3/16 in.	2	Socket Cap Screws	Allen
5-20	9/16 in.	6	Hex Cap Screws	Socket
7-20	9/16 in.	4	Hex Cap Screws	Socket
12	1 in.	1	Breather Assembly	Socket
13	3/4 in.	2	Vent Check Assembly	Open End
-	3/8 sq. in.	1	Tension rod	Male Drive Extension

## 6.5 FG/FGC4 Tool Style and Wrench Size FGH3/FGHC3 for Item Number 3-20 to 3-130

**Table 18. FG/FGC4 Tool Style and Wrench Size FGH3/FGHC3 for Item Number 3-20 to 3-130**

Item Number	Wrench Size	Item Quantity	Location or Description	Recommended Tool Style
1-110	9/16 in.	8	Hex Cap Screws	Socket
1-160	9/16 in.	4	Hex Cap Screws	Socket
1-180	3/4 sq. in.	2	Stop Screws	Open End or Adjustable
1-190	1-13/16 in.	2	Hex Jam Nuts	Open End or Adjustable
3-20	5/8 in.	2	Tie Bar (flats)	Open End or Adjustable
3-40	1/2 sq. in.	1	Piston Rod	Male Drive Extension
3-90	1-5/8 in.	2	Standard Hex Nuts	Socket
3-100	3/4 in.	6	Hex Cap Screws	Socket
3-120	5/8 sq. in.	1	Pipe Plug	Open End or Adjustable
3-130	3/16 in.	2	Socket Cap Screws	Allen
5-20	3/4 in.	6	Hex Cap Screws	Socket
7-20	9/16 in.	4	Hex Cap Screws	Socket
12	1 in.	1	Breather Assembly	Socket
13	3/4 in.	2	Vent Check Assembly	Open End
-	3/4 in.	1	Tension rod	Male Drive Extension

## 6.6 FG/FGC5 Tool Style and Wrench Size FGH4/FGHC4 for Item Number 3-20 to 3-130

**Table 19. FG/FGC5 Tool Style and Wrench Size FGH4/FGHC4 for Item Number 3-20 to 3-130**

Item Number	Wrench Size	Item Quantity	Location or Description	Recommended Tool Style
1-110	3/4 in.	8	Hex Cap Screws	Socket
1-120	3/4 in.	4	Hex Cap Screws	Socket
1-160	9/16 in.	6	Hex Cap Screws	Socket
1-180	7/8 sq. in.	2	Stop Screws	Open End or Adjustable
1-190	2-3/8 in.	2	Heavy Hex Jam Nuts	Open End or Adjustable
3-20	1/2 sq. in.	2	Tie Bar (flats)	Open End or Adjustable
3-40	1/2 sq. in.	1	Piston Rod	Male Drive Extension
3-90	2 in.	2	Standard Hex Nuts	Socket
3-100	3/4 in.	8	Hex Cap Screws	Socket
3-120	1-1/8 sq. in.	1	Pipe Plug	Open End or Adjustable
3-130	3/16 in.	2	Socket Cap Screws	Allen
5-20	3/4 in.	8	Hex Cap Screws	Socket
7-20	9/16 in.	4	Hex Cap Screws	Socket
12	1 in.	1	Breather Assembly	Socket
13	3/4 in.	2	Vent Check Assembly	Open End
-	3/4 in.	1	Tension rod	Male Drive Extension

## 6.7 FG/FGC7 Tool Style and Wrench Size FGH5/FGHC5 for Item Number 3-20 to 3-130

**Table 20. FG/FGC7 Tool Style and Wrench Size FGH5/FGHC5 for Item Number 3-20 to 3-130**

Item Number	Wrench Size	Item Quantity	Location or Description	Recommended Tool Style
1-110	3/4 in.	8	Hex Cap Screws	Socket
1-120	3/4 in.	4	Hex Cap Screws	Socket
1-160	9/16 in.	8	Hex Cap Screws	Socket
1-180	1 in.	2	Stop Screws	Open End or Adjustable
3-20	3/4 sq. in.	2	Tie Bar (female square)	Male Drive Extension
3-40	3/4 sq. in.	1	Piston Rod	Male Drive Extension
3-90	2-3/8 in.	2	Standard Hex Nuts	Socket
3-100	15/16 in.	8	Hex Cap Screws	Socket
3-120	1-1/8 sq. in.	1	Pipe Plug	Open End or Adjustable
3-130	3/16 in.	2	Socket Cap Screws	Allen
5-20	15/16 in.	8	Hex Cap Screws	Socket
7-20	9/16 in.	8	Hex Cap Screws	Socket
12	1 in.	1	Breather Assembly	Socket
13	3/4 in.	2	Vent Check Assembly	Open End
-	3/4 in.	1	Tension rod	Male Drive Extension

## 6.8 FG/FGC8 Tool Style and Wrench Size FGH7/FGHC7 for Item No 3-20 to 3-130

**Table 21. FG/FGC8 Tool Style and Wrench Size FGH7/FGHC7 for Item Number 3-20 to 3-130**

Item Number	Wrench Size	Item Quantity	Location or Description	Recommended Tool Style
1-110	3/4 in.	12	Hex Cap Screws	Socket
1-120	3/4 in.	4	Hex Cap Screws	Socket
1-160	9/16 in.	8	Hex Cap Screws	Socket
1-180	1-1/4 in.	2	Stop Screws	Open End or Adjustable
3-20	3/4 sq. in.	2	Tie Bar (female square)	Male Drive Extension
3-40	3/4 sq. in.	1	Piston Rod	Male Drive Extension
3-90	2-3/4 in.	2	Heavy Hex Nuts	Socket
3-100	1-1/8 in.	8	Hex Cap Screws	Socket
3-120	1-5/16 sq. in.	1	Pipe Plug	Open End or Adjustable
3-130	3/16 in.	2	Socket Cap Screws	Allen
5-20	1-1/8 in.	8	Hex Cap Screws	Socket
7-20	1-1/8 in.	8	Hex Cap Screws	Socket
12	1 in.	1	Breather Assembly	Socket
13	3/4 in.	2	Vent Check Assembly	Open End
-	3/4 in.	1	Tension rod	Male Drive Extension

## 6.9 FG/FGC10 Tool Style and Wrench Size FGH8/FGHC8 for Item Number 3-20 to 3-130

**Table 22. FG/FGC10 Tool Style and Wrench Size FGH8/FGHC8 for Item Number 3-20 to 3-13**

Item Number	Wrench Size	Item Quantity	Location or Description	Recommended Tool Style
1-110	3/4 in.	16	Hex Cap Screws	Socket
1-120	3/4 in.	4	Hex Cap Screws	Socket
1-160	9/16 in.	8	Hex Cap Screws	Socket
1-180	1-1/2 in.	2	Stop Screws	Open End or Adjustable
3-20	3/4 sq. in.	2	Tie Bar (female square)	Male Drive Extension
3-40	3/4 sq. in.	1	Piston Rod	Male Drive Extension
3-90	3-1/2 in.	2	Heavy Hex Nuts	Socket
3-100	1-5/16 in.	8	Hex Cap Screws	Socket
3-120	1-5/16 sq. in.	1	Pipe Plug	Open End or Adjustable
3-130	3/16 in.	2	Socket Cap Screws	Allen
5-20	1-1/8 in.	8	Hex Cap Screws	Socket
7-20	1-5/16 in.	8	Hex Cap Screws	Socket
12	1 in.	1	Breather Assembly	Socket
13	3/4 in.	2	Vent Check Assembly	Open End
-	3/4 in.	1	Tension rod	Male Drive Extension

## 6.10 FG13 Tool Style and Wrench Size FGH10/FGHC10 for Item Number 3-20 to 3-130

**Table 23. FG13 Tool Style and Wrench Size FGH10/FGHC10 for Item Number 3-20 to 3-130**

Item Number	Wrench Size	Item Quantity	Location or Description	Recommended Tool Style
1-110	1-1/8 in.	20	Hex Cap Screws	Socket
1-120	1-1/8 in.	4	Hex Cap Screws	Socket
1-160	9/16 in.	12	Hex Cap Screws	Socket
1-180	2 sq. in.	2	Stop Screws	Open End or Adjustable
3-20	3/4 sq. in.	2	Tie Bar (female square)	Male Drive Extension
3-40	3/4 sq. in.	1	Piston Rod	Male Drive Extension
3-90	4-1/4 in.	2	Heavy Hex Nuts	Socket
3-100	1-11/16 in.	8	Hex Cap Screws	Socket
3-120	1-7/8 sq. in.	1	Pipe Plug	Open End or Adjustable
3-130	3/16 in.	2	Socket Cap Screws	Allen
5-20	1-13/16 in.	8	Hex Cap Screws	Socket
7-20	1-1/8 in.	8	Hex Cap Screws	Socket
12	1 in.	1	Breather Assembly	Socket
13	3/4 in.	2	Vent Check Assembly	Open End
-	3/4 in.	1	Tension rod	Male Drive Extension

## 6.11 FG/FGC/FGH/FGHC Module Assemble Ratchet Extension Size

The minimum ratchet extension length required for each FG body size to assemble Power Modules and Spring Modules to Drive Modules is shown in the following table.

**Table 24. Ratchet Extension Size Table**

Actuator Model	Ratchet Length	Power Modules	Spring Modules
FG01	10 in.	3/8 in. Male Drive	3/8 in. Male Drive
FG2	12 in.	3/8 in. Male Drive	3/8 in. Male Drive
FG3	14 in.	3/8 in. Male Drive	3/8 in. Male Drive
FG4	16 in.	1/2 in. Male Drive	3/4 in. Male Drive
FG5	19 in.	1/2 in. Male Drive	3/4 in. Male Drive
FG7	26 in.	3/4 in. Male Drive	3/4 in. Male Drive
FG8	30 in.	3/4 in. Male Drive	3/4 in. Male Drive
FG10	37 in.	3/4 in. Male Drive	3/4 in. Male Drive

# Section 7: Troubleshooting

## 7.1 Fault Insertion

In the unlikely event of a fault developing, the following Fault Location Table is provided to assist the service engineer to perform troubleshooting. This table is designed to cover as wide a range of Biffi actuators as possible. Reference to equipment not supplied should be ignored.

**Table 25. Fault Location Table**

Symptom	Potential Causes	Remedy
Erratic movement	Irregular supply of operating medium	Check operating medium for consistent supply pressure and correct as necessary.
	Inadequate lubrication	Dismantle, relubricate and reassemble.
	Worn parts	Dismantle. Visually inspect for significant wear. Actuator replacement may be required.
Short stroke	Defective valve	Consult the valve OEM's documentation.
	Incorrectly set stops (valve and/or actuator)	Check the position of the travel stops and readjust as necessary.
	Hardened grease	Dismantle, remove any hard grease, relubricate and reassemble.
	Debris left in the cylinder or housing during maintenance	Disassemble cylinder assembly to remove debris. Reassemble cylinder assembly as necessary.
Apparent lack of torque	Defective valve	Consult the valve manufacturer's documentation.
	Inadequate supply pressure	Ensure supply pressure is above the minimum operating pressure of the actuator and that output torque produced at supply pressure exceeds valve torque demand.
	Incorrect speed control settings	Adjust speed controls to increase flow.
	Exhaust port blocked	Remove and clean the exhaust port silencers and replace.
	Pipe work blocked, crushed or leaking	Examine the pipe work for blockages, crushed pipe or leakage. Clear or replace as necessary.
	Defective controls	Examine the controls, refurbish or renew as necessary. Refer to component manufacturer's documentation.
	Defective piston seal	Dismantle the cylinder assembly, remove the defective piston seal. Fit new seal and reassemble.
	Defective rod seal	Dismantle the cylinder assembly, remove the defective rod seal. Fit new seal and reassemble.
Defective housing seal	Dismantle the housing assembly, remove the defective seal. Fit new seal and reassemble.	
	High valve torque or valve seized	Consult the valve OEM documentation.

## 7.2 Operational Test

### 7.2.1 Full Stroke Test

The "Full Stroke Test" ("On-line") must be performed to satisfy the  $PFD_{AVG}$  (average probability of failure on demand) value. The full stroke test frequencies will be defined by the final installer to achieve the defined SIL level.

#### 7.2.1.1 Procedure

**7.2.1.1.1** Stroke the actuator/valve assembly two complete open/close cycles with complete closing of the valve.

**7.2.1.1.2** Verify the open/close cycles functioned correctly (e.g., check locally, or automatically via Logic solver, the correct movement of the actuator/valve).

Upon successful completion of the above described Full Stroke Test procedure, the "Test Coverage" can be considered 99%.

### 7.2.2 Partial Stroke Test (when requested)

The "Partial Stroke Test" ("On-line") can be performed to improve the  $PFD_{AVG}$  value and to satisfy  $PFD_{AVG}$  value. A typical partial stroke value is 15% of the stroke and the recommended test interval is about every one to three months.

#### 7.2.2.1 Procedure

**7.2.2.1.1** Operate the actuator/valve assembly for No° 1 open/close cycles 15% of the stroke.

**7.2.2.1.2** Verify the partial stroke test functioned correctly (e.g., check locally, or automatically via logic solver, or via the PST system the correct movement of the actuator/valve was 15% of the stroke).

---

**NOTE:**

The above test is only applicable on systems equipped with a partial stroke feature.

---

## Section 8: Removal and Decommissioning

### **WARNING**

Always follow safe work practices to remove and disassemble FG-Series actuator.

The below basic procedure should not supersede or replace any customer's plant safety or work procedures. If a conflict arises between this procedure and the customer's procedures, the differences should be resolved in writing between an authorized customer's representative and an authorized Biffi representative.

### **CAUTION**

Make sure actuator is isolated before removing from valve. Turn OFF the power medium and bleed off all pressure first, including storage tank (if present). Next, bleed off pilot pressure, then disconnect the pneumatic pressure supply, pilot tubing and electrical wiring (if equipped).

Before starting the disassembly, a large area should be created around the actuator so to allow any kind of movement.

Separate the parts composing the actuator according to their nature (e.g., metallic and plastic materials, fluids, etc.) and send them to differentiated waste collection sites, as provided for by the laws and provisions in force.

1. Drain tanks and remove tubing from actuator. Remove accessories (if equipped) and controls from actuator.
2. Remove all equipment mounted on top of actuator (limit switches, end of stroke valve, relevant pneumatic/electric connection, etc.).
3. Remove mounting bolts, and actuator is ready to be removed from valve. For complete actuator tear down, refer to Section 2 of the manual.

# Section 9: Document Revision

**Table 26. Revision Overview**

Parent Document	Revision Number	Status	Date
124840E/VCIOM-13493-EN	3	Updated	April 2024
124840E/VCIOM-13493-EN	4	Updated	February 2026

**NOTE:**

The data in this table refers to the parent document (VCIOM-13493-EN).

## Appendix A: List of Tables

Table 1.	Rod Extension Retainer Nut Tool Part Number.....	4
Table 2.	Housing Cover Screw Quantity and Torque Table .....	21
Table 3.	Piston Rod Number of Turns Table .....	23
Table 4.	Piston Rod Required Torque Table .....	24
Table 5.	Tie Bar Nuts Required Torque Table .....	27
Table 6.	Early FG2 and FG3 Tie Bar Nuts Required Torque Table .....	31
Table 7.	Tension Rod Number of Turns Table.....	43
Table 8.	Spring Cartridge Tension Rod Torque Table .....	44
Table 9.	Hex Cap Screws (7-20) Torque Table.....	45
Table 10.	Wire Length Requirements.....	45
Table 11.	Piston Rod/Tension Rod Number of Turns Table .....	48
Table 12.	Spring Cartridge Tension Rod Torque Table .....	49
Table 13.	FG/FGC/FGH/FGHC Module Weights By Item Number And Actuator Housing Size (1).....	52
Table 14.	FG/FGC/FGH/FGHC Module Weights By Item Number And Actuator Housing Size (2).....	53
Table 15.	FG01 Tool Style and Wrench Size.....	53
Table 16.	FG/FGC2 Tool Style and Wrench Size.....	54
Table 17.	FG/FGC3 Tool Style and Wrench Size FGH2/FGHC2 For Item Number 3-20 to 3-130 .....	54
Table 18.	FG/FGC4 Tool Style and Wrench Size FGH3/FGHC3 For Item Number 3-20 to 3-130 .....	55
Table 19.	FG/FGC5 Tool Style and Wrench Size FGH4/FGHC4 For Item Number 3-20 to 3-130 .....	55
Table 20.	FG/FGC7 Tool Style and Wrench Size FGH5/FGHC5 For Item Number 3-20 to 3-130 .....	56
Table 21.	FG/FGC8 Tool Style and Wrench Size FGH7/FGHC7 For Item Number 3-20 to 3-130 .....	56
Table 22.	FG/FGC10 Tool Style and Wrench Size FGH8/FGHC8 For Item Number 3-20 to 3-130 .....	57
Table 23.	FG13 Tool Style and Wrench Size FGH10/FGHC10 For Item Number 3-20 to 3-130 .....	57
Table 24.	Ratchet Extension Size Table .....	58
Table 25.	Fault Location Table.....	59
Table 26.	Revision Overview .....	62
Table C-1.	Temperature Range for (Potential) Explosive Areas.....	74

# Appendix B: List of Drawings

## B.1 Part Number 116422, FGXXX Pneumatic Assembly Drawing, Sheet 1 of 2

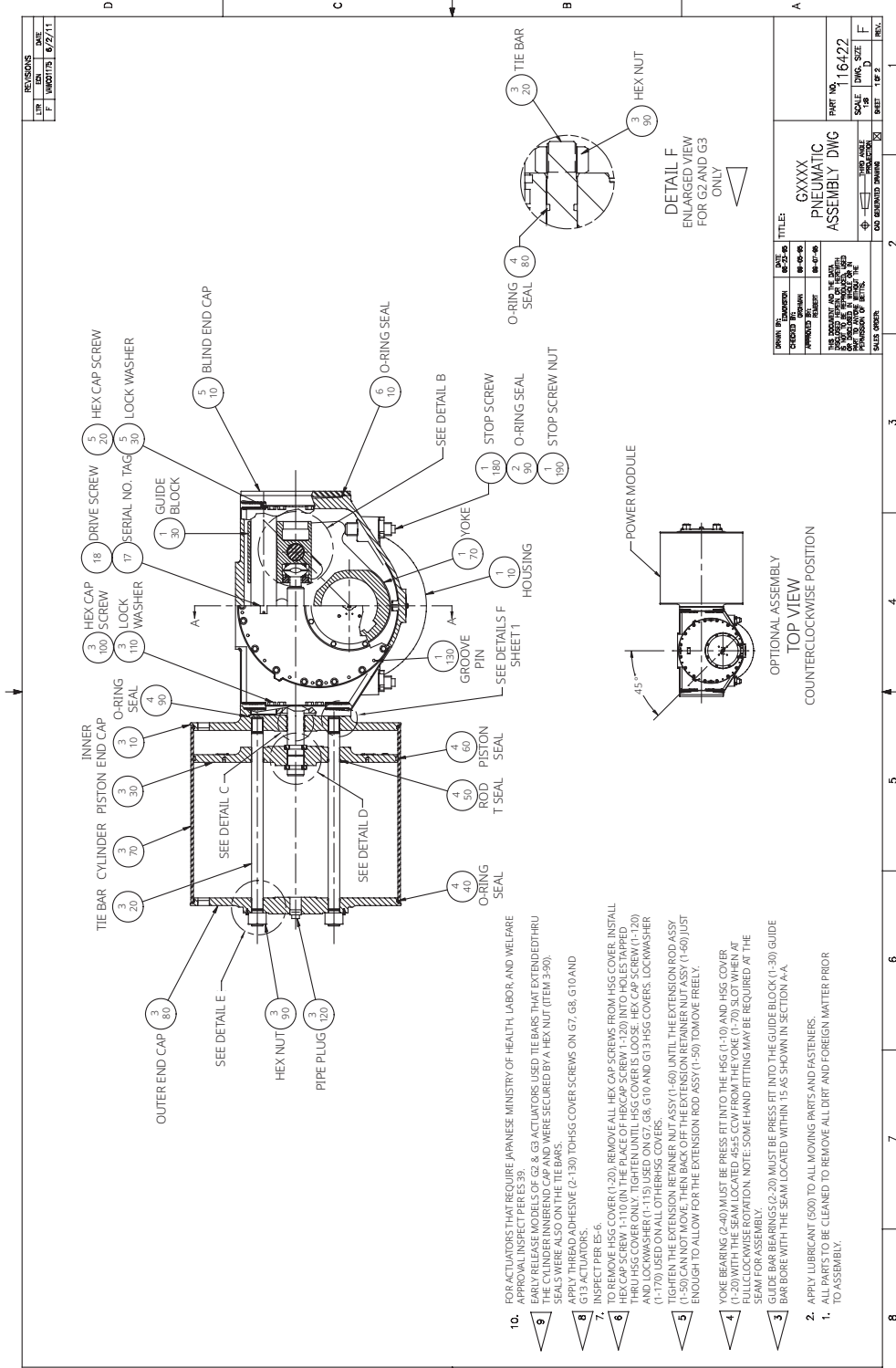

# B.2 Part Number 116422, FGXXX Pneumatic Assembly Drawing, Sheet 2 of 2

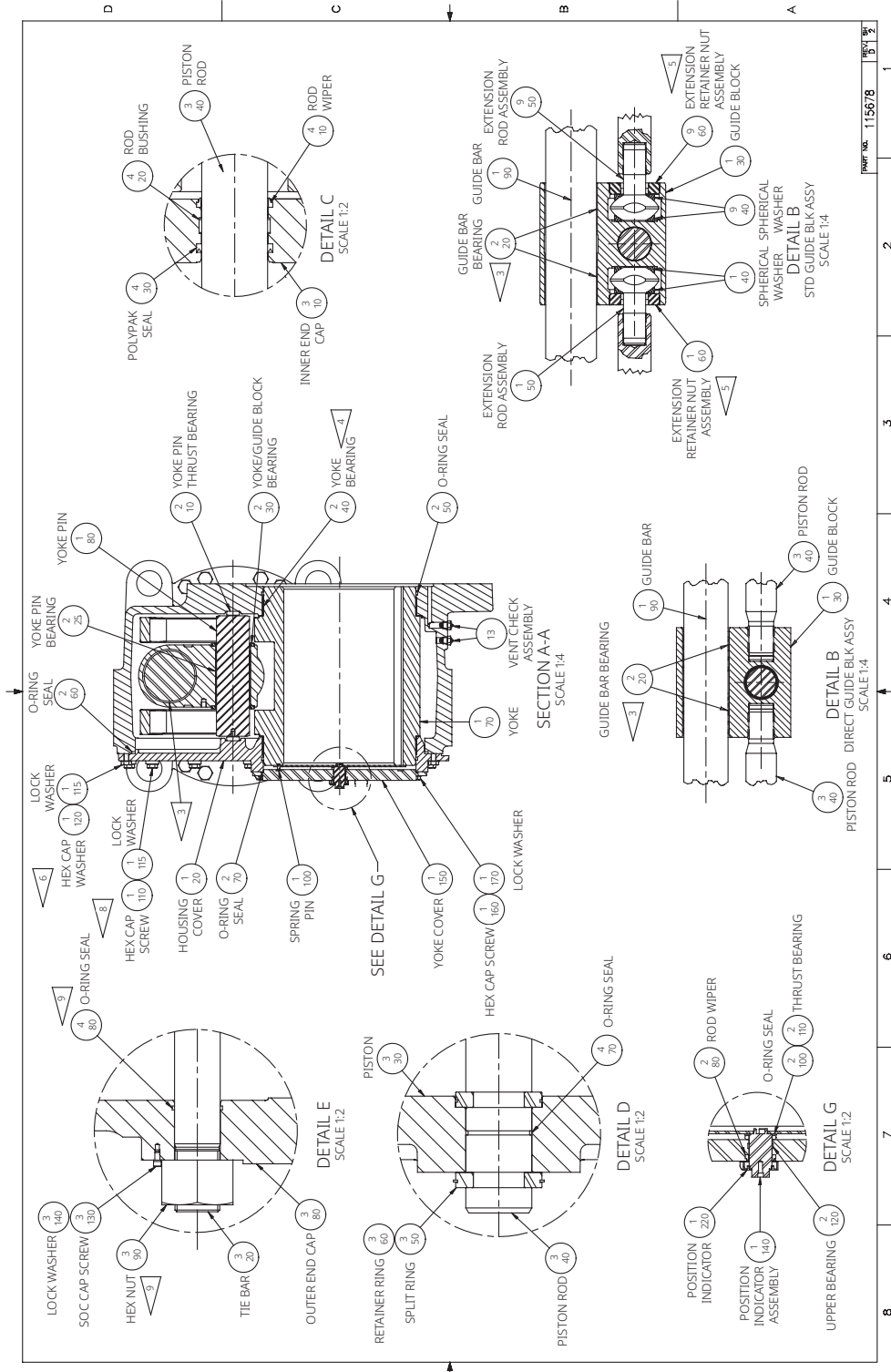

# B.3 Part Number 115678, FGXX2XX Pneumatic Assembly Drawing, Sheet 1 of 2

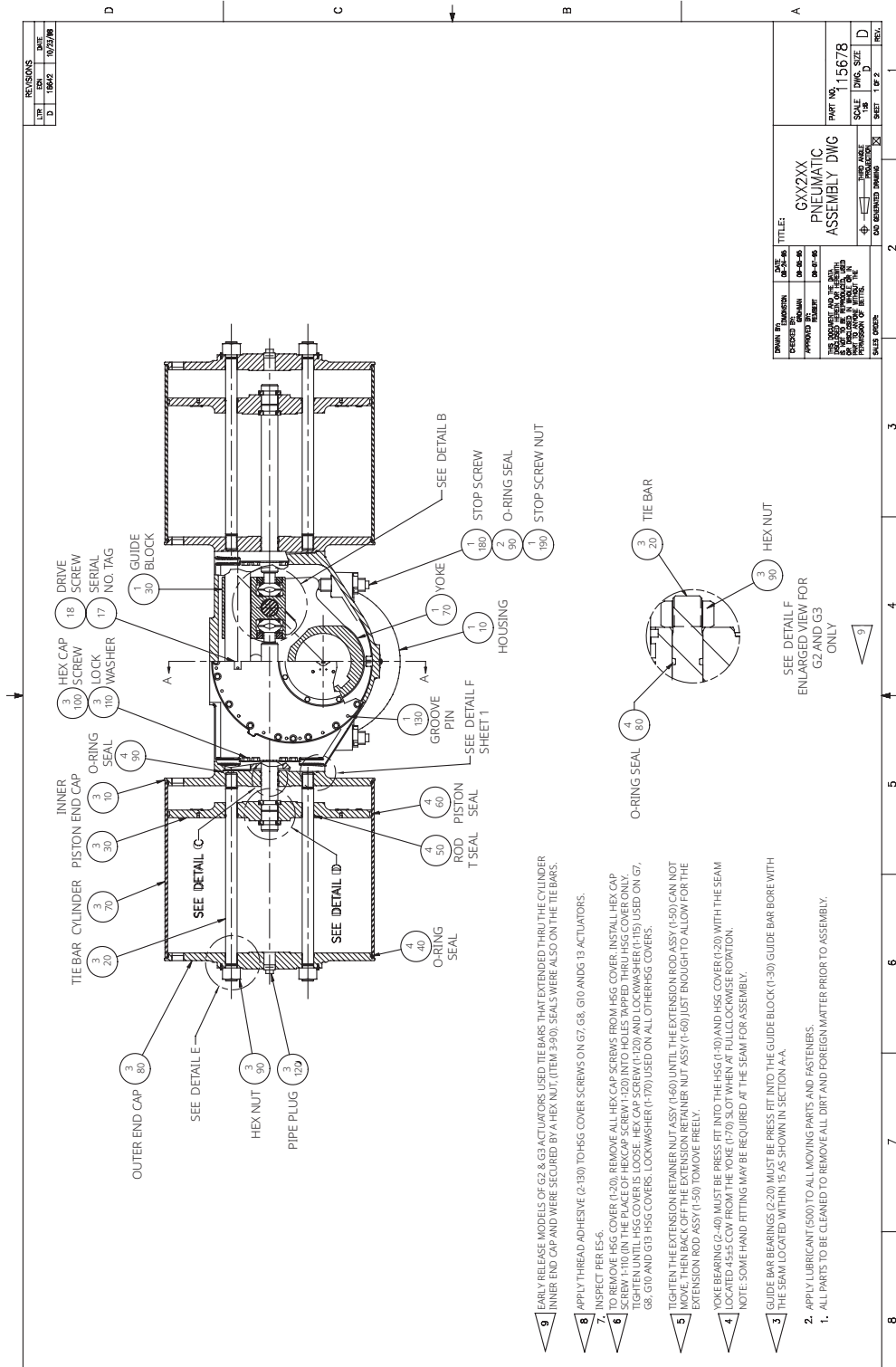



# B.5 Part Number 115674, FGXXX-SRX Pneumatic Assembly Drawing, Sheet 1 of 2

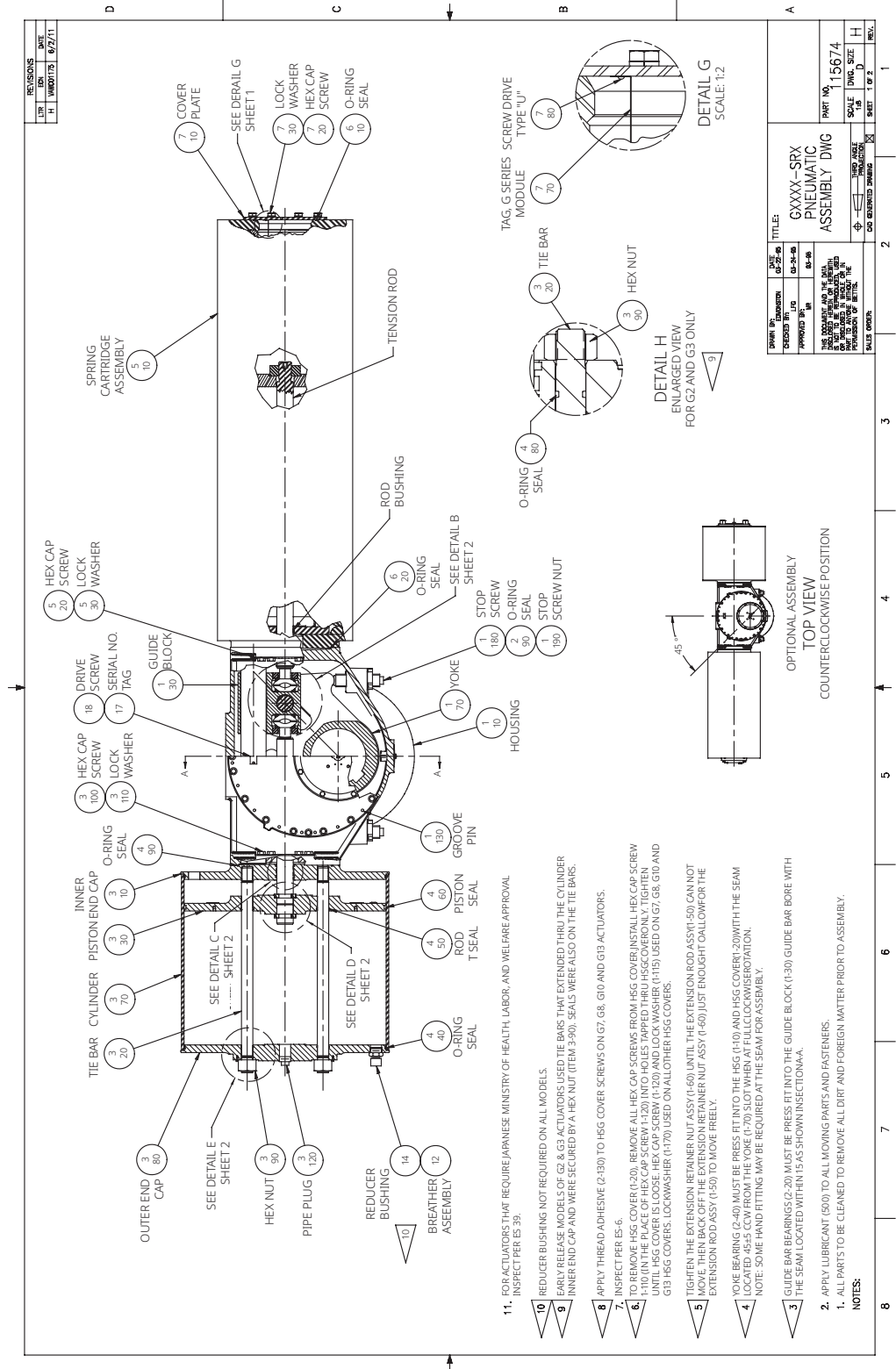





# B.8 Part Number 140952, FGH/FGHCXXX-SRX Pneumatic Assembly Drawing, Sheet 2 of 2

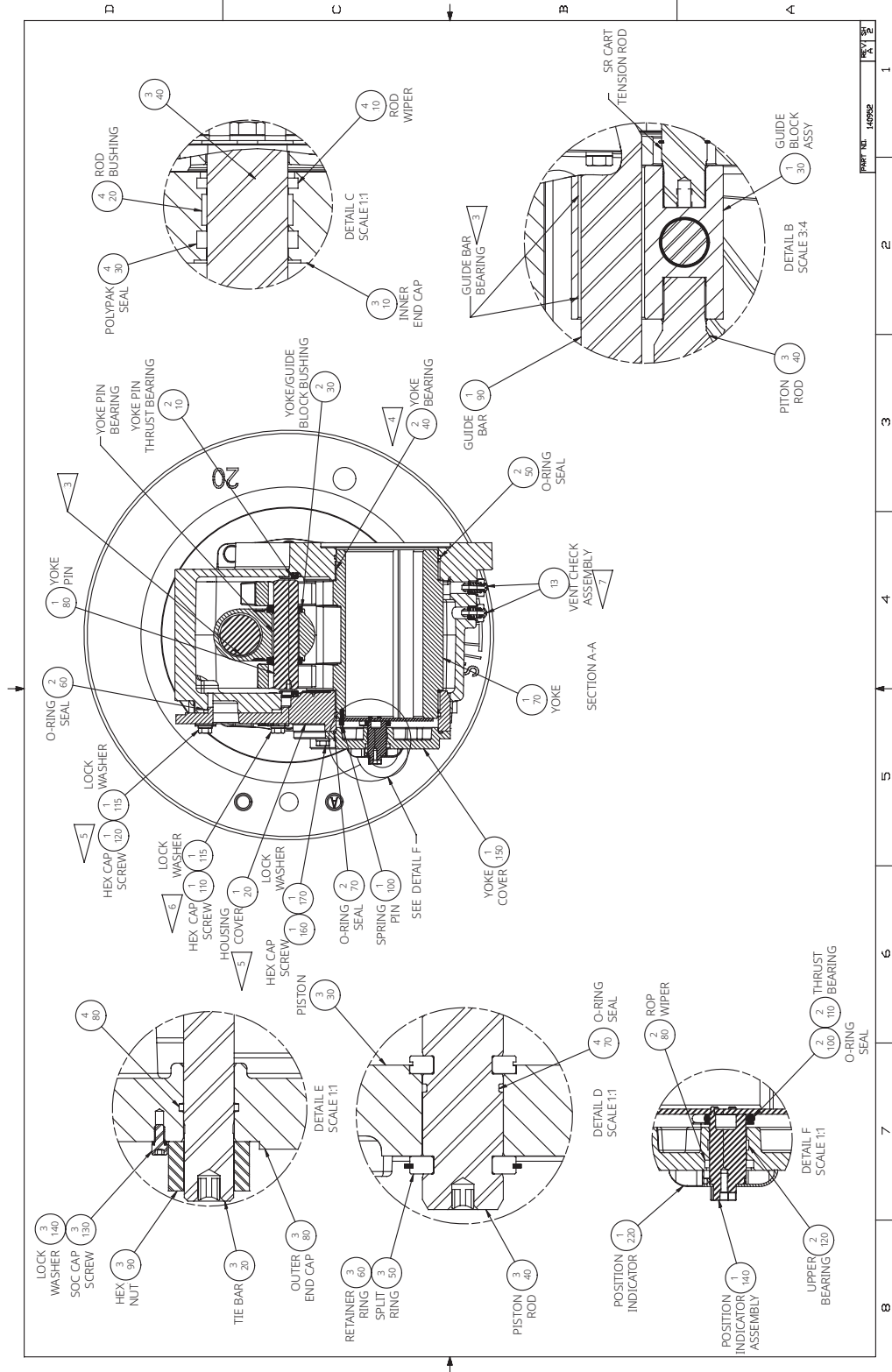

# Appendix C: Safety Instructions for Use in (Potential) Explosive Atmosphere



## C.1 Intended Use

The actuator series have been designed to comply with the explosion safety requirements in the Ex-standards EN IEC 60079-0:2018, EN ISO 80079-36, EN ISO 80079-37:2016 and EN 1127-1:2019. These standards contain the requirements for non-electrical equipment in potentially explosive atmospheres.

The actuators comply with the constructional safety type "c" requirements. The actuators are designed for gas group IIB or IIC and dust group IIIC applications and are applicable in temperature classes T6 to T3 depending on model. The Equipment Protection Level is Gb for gas and Db for dust, so the actuators can be used in Ex classified hazardous zones 1/21.

## C.2 Explosive Atmosphere Marking

### Complete Explosive Atmosphere Marking:

  II 2 G Ex h IIB or IIC T6 to T3 Gb  
II 2 D Ex h IIIC T85 to T200 °C Db

### Ambient Temperature Ranges ( $T_{amb}$ ):

- Standard Temperature: -20 to +200 °F / -29 to +93 °C
- Low Temperature: -40 to +150 °F / -40 to +65 °C
- High Temperature: 0 to 350 °F / -18 to +176 °C

---

### NOTES:

1. The minimum and maximum temperature can vary according to the project design (gaskets, O-rings and grease used) as well as other certifications within the given range. Please refer to the special conditions for safe use.
  2. Hazardous area is likely to occur in normal operation occasionally in greater than 10 and less than 1000 hours/year.
-

## C.3 Safety Instructions

1. Before the installation, please carefully read the service instructions. Biffi is not responsible for damages caused by operations not complying with the instruction in such manuals.
2. All the operations shall be done by a trained and qualified operator. All maintenance operations must be performed in accordance with the instructions detailed in the maintenance manual.
3. The assembly cannot be installed and used in classified areas as zone 0 to 20, mines (group I).
4. The equipment shall be installed in a place where the risk of lightning is covered by the relevant industrial code of practice.
5. Assembly, disassembly and maintenance is only allowed at the actuator, when at the time of the activity, there are no explosive mixtures.
6. During maintenance operations, the user must take all appropriate measures to prevent risks related to the toxicity of substances, using appropriate protective equipment (e.g., gloves, goggles, face mask), according to the extent provided the technical and organizational point of use and the recommendations provided in the specifications of the used substances.
7. All the mechanical components do not have ignition sources during the normal working process. The user shall check periodically the vibration presence and/or abnormal noises and it must stop the unit immediately, check the causes and contact the manufacturer.
8. Actuators do not have an inherent ignition source due to electrostatic discharge, but explosion hazards may be present due to the discharge of static electricity from other valve assembly components.
  - a. To avoid personal injury or property damage, make sure that the valve is grounded to the pipeline before placing the valve assembly into service.
  - b. Use and maintain alternate shaft-to-valve body bonding, such as a shaft-to-body bonding strap assembly.
  - c. The equipment must be earthed through an anti-loosening and anti-rotation device. The user must regularly check the effectiveness of the ground connection.
  - d. A warning is present into the label: "Potential electrostatic charging hazard".
9. When equipment is installed in a hazardous area location (potentially explosive atmosphere), prevent sparks by proper tool selection and avoiding other types of impact energy.
10. It is the end user's responsibility to avoid allowing the explosive mixture from entering the actuator. As such, safe air from outside of the Ex-zone (Safe Area) must be used to feed the pneumatic cylinder.

**Note:** For single acting actuators, a closed-loop control system is one of the options that can be used to avoid allowing the explosive mixture from entering the actuator.

11. Regularly clean dust deposits from the actuator to minimize the risk of explosion due to dust.
12. Proper care must be taken to avoid generation of static electricity on the non-conductive external surfaces of the equipment (e.g., rubbing of surfaces, etc.).
13. The paint protection must not exceed 200 µm if the actuator is used in a group IIC atmosphere. For group IIA or IIB atmospheres, the paint protection must not exceed a thickness of 2 mm / 0.08 in.
14. After maintenance operations are carried out, perform a few actuator operations to check that its movement is regular and that there is no air/oil leakage through the seals/gaskets.
15. It is under end user responsibility to make sure the electrical equipment installed on the actuators have a separated Explosive Atmosphere evaluation and they are designed according to the Explosive Atmosphere Directive/Regulation, and they are suitable for the installation zone, group of gas, temperature class, maximum surface temperature, EPL and range of temperature.
16. Using this equipment in ways not specified in the instruction manual is not permitted. Emerson is not liable for any damages resulting from improper or hazardous use.

## C.4 Maximum Temperatures

### WARNING

The actuator's surface temperature is dependent upon process operating conditions. Personal injury or property damage caused by fire or explosion, can result if the actuator's surface temperature exceeds the acceptable temperature for the hazardous area classification. To avoid an increase of instrumentation and/or accessory surface temperature due to process operating conditions, ensure adequate ventilation, shielding or insulation of these actuator components installed in a potentially hazardous or explosive atmosphere.

**Table C-1. Temperature Range for (Potential) Explosive Areas**

Ambient Range	Temperature		Valid Actuator Trim
	Explosive Atmosphere Class	TX (Explosive Atmosphere Surface Temperature)	
-29 to +75 °C / -20 to +167 °F	T6	T85 °C / T185 °F	Standard Temperature Trim
-29 to +90 °C / -20 to +194 °F	T5	T100 °C / T212 °F	
-29 to +93 °C / -20 to +200 °F	T4	T103 °C / T217 °F	
-40 to +65 °C / -40 to +150 °F	T6	T75 °C / T167 °F	Low Temperature Trim
-18 to +125 °C / 0 to 257 °F	T4	T135 °C / T275 °F	High Temperature Trim
-18 to +176 °C / 0 to 350 °F	T3	T186 °C / T367 °F	

**Notes:**

The specified values are valid with condition: Maximum cycle frequency of actuator is less than 1 Hz at a maximum of 50 cycles per hour and at maximum load.

*This page is intentionally left blank.*

<https://www.biffi.it/en-us>

VCIOM-17270-EN ©2026 Biffi. All rights reserved. All other marks are the property of their respective owners.

Neither Emerson nor any of its affiliated entities assume responsibility for the selection, use or maintenance of any product. Responsibility for proper selection, use, and maintenance of any product remains solely with the purchaser and end user.

The contents of this publication are presented for informational purposes only, and while every effort has been made to ensure their accuracy, they are not to be construed as warranties or guarantees, express or implied, regarding the products or services described herein or their use or applicability. All sales are governed by our terms and conditions, which are available upon request. We reserve the right to modify or improve the designs or specifications of such products at any time without notice.

