

# GIL DOUBLE ACTING DIRECT GAS LINEAR ACTUATOR

## INSTALLATION, OPERATION AND MAINTENANCE MANUAL

Before installation these instructions must be read fully and understood



### 1.1.1 Applicable regulations

- EN ISO 12100-1: 2005: Safety of machinery - Basic notions, general design principles. Part 1 - Basic terminology method.
- EN ISO 12100-2: 2005: Safety of machinery - Basic notions, general design principles. Part 2 - Technical principles and specification.
- 2006/42/EC: Machinery directive.
- 97/23/EC: Directive for pressure equipment (PED).
- 2006/95/EC: Directive for low voltage equipment.
- 2004/108/EC: Directive for electromagnetic compatibility.
- 94/9/EC: Directive and safety instructions for use in hazardous areas.

### 1.1.2 Terms and conditions

Biffi guarantees that all the items produced, if installed, used and subjected to maintenance, are without material and manufacturing defects and comply with specifications in force. The warranty period is one year, starting from the date of installation by the first user of the product, or eighteen months as of the date of shipment to the first user, depending on which event occurs first.

The warranty does not cover special products or components not covered by warranty in their turn by subcontractors, or materials that were used or installed inappropriately, or which were modified or repaired by unauthorized staff.

If the failure was caused by inappropriate installation, maintenance or use, or by irregular working conditions, the repairs will be charged according to the applicable fees.

## TABLE OF CONTENTS

1	General warnings.....	1
2	Installation.....	3
3	Operation and use.....	7
4	Operational tests and inspections.....	20
5	Maintenance.....	20
6	Troubleshooting.....	25
7	Layouts.....	25
8	Date report for maintenance operations....	34

## 1 GENERAL WARNINGS

### IMPORTANT

*The manual is an integral part of the machine. It should be read carefully before carrying out any operation and should be kept for future reference.*

### 1.1 Generalities

Biffi actuators are conceived, manufactured and controlled according to a Quality Control System in compliance with the EN ISO 9001 international regulation.

# GIL DOUBLE ACTING DIRECT GAS LINEAR ACTUATOR

## INSTALLATION, OPERATION AND MAINTENANCE MANUAL

FIGURE 1  
Data plate



### 1.2 Identification plate

It is forbidden to modify the information and marks without previous written authorization by Biffi. The plate fastened on the actuator contains the information shown in figure 1.

### 1.3 Introducing the actuator

GIL double acting pneumatic high-pressure linear actuators are suitable for the operation of linear valves (wedge gate valves, through conduit gate valves) for ON-OFF and modulating heavy-duty service.

The actuator comprises a pneumatic cylinder and a mounting pedestal complete with a joint for coupling the valve stem to the actuator output stem. The valve is actuated in opening and closing positions by the actuator pneumatic cylinder that is pressurized in one or in the other direction.

The linear stroke of the valve is adjustable by means of the external mechanical stop for upward position and by the adjustment of the coupling of the valve stem to actuator joint for the downward position.

The actuator pedestal has a flange with threaded holes to fix the actuator to the valve. Different types of control system can be supplied to meet customers' requirements. The expected lifetime of the actuator is approximately 25 years.

FIGURE 2  
Identification of actuator parts

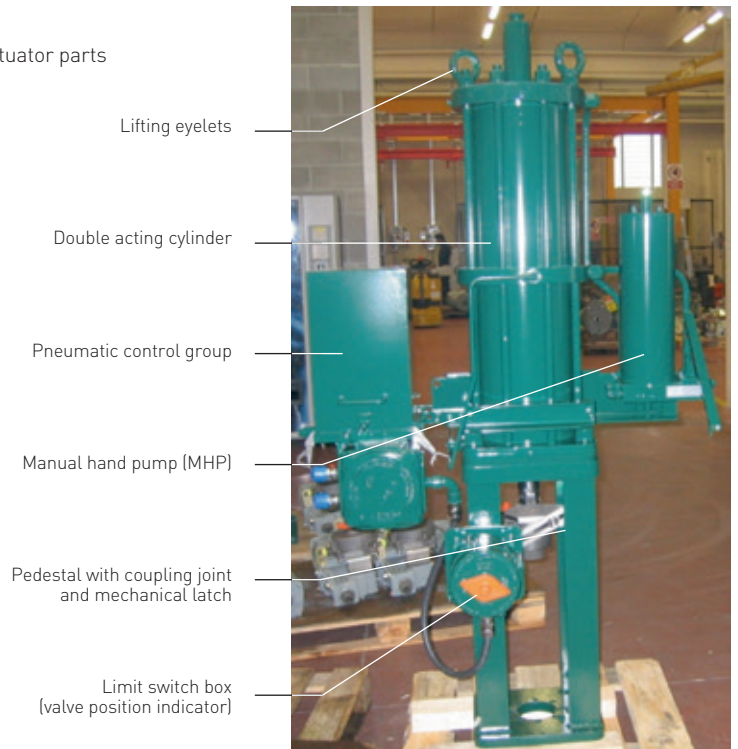

### SELECTION GUIDE

Example:	GIL	250K	585	300	MHP
<b>GIL</b> Actuator series					
<b>250K</b> Max. allowable thrust (N)					
<b>585</b> Cylinder diameter (mm)					
<b>300</b> Stroke (mm)					
<b>MHP</b> Manual override					

### 1.4 Technical data

Supply fluid	Air, nitrogen or sweet gas
Operating temperature	Standard: from -30°C to +100°C Optional: from -60° to +140°C
Supply pressure	From 10 to 105 barg maximum

# GIL DOUBLE ACTING DIRECT GAS LINEAR ACTUATOR

## INSTALLATION, OPERATION AND MAINTENANCE MANUAL

### 2 INSTALLATION

#### 2.1 Checks upon actuator receipt

- Check that the model, the serial number of the actuator and the technical data reported on the identification plate correspond with those of the order confirmation (section 1.2).
- Check that the actuator is equipped with the fittings as per the order confirmation.
- Check that the actuator was not damaged during transportation: if necessary renovate the painting according to the specification reported on the order confirmation.
- If the actuator is received already assembled with the valve, its settings have already been made at the factory.  
If the actuator is delivered separately from the valve, it is necessary to check and, if required, to adjust the settings of the mechanical stops (section 3.4) and of microswitches (if any) (section 3.5).

#### 2.2 Actuator handling

##### IMPORTANT

Lifting and handling should be carried out by qualified staff and in compliance with the laws and provisions in force.

##### WARNING

The fastening points are appropriate for the lifting of the actuator alone and not for the valve + actuator assembly.  
During handling, avoid passing the actuator above personnel.  
The actuator should be handled with appropriate lifting means. The weight of the actuator is reported on the delivery bill.

#### 2.3 Storage

If the actuator needs storage before installation, follow these steps:

- Place it on a wood surface to preserve the area of the valve coupling.
- Make sure that plastic plugs are present on the pneumatic and electrical connections (if present).
- Check that the cover of the control group and of the limit switch box (if any) are closed properly.

If the storage is long-term or outdoor:

- Keep the actuator protected from direct weather conditions.
- Replace plastic plugs of pneumatic and electrical connections (if any) with metal plugs that guarantee perfect tightness.
- Coat the valve coupling area with oil, grease or protection disc.
- Operate the actuator periodically (section 3.3).

#### 2.4 Actuator assembly on the valve

##### 2.4.1 Types of assembly

The adapter pedestal in fabricated carbon steel is designed specifically for adaptation to any type of valve with provision for local indicator, limit switches and other accessories (on request).

Lift the actuator by safety-hook for chains using the lifting-points (see section 2.2) on the top of actuator for handling, transporting and assembling in vertical position (see figure 3). For handling, transporting and assembling the actuator in horizontal position by safety-hook for chains, use the lifting-points on the top of cylinder head-flange and on the coupling flange (see figure 4).

FIGURE 3  
Lifting points for GIL actuators

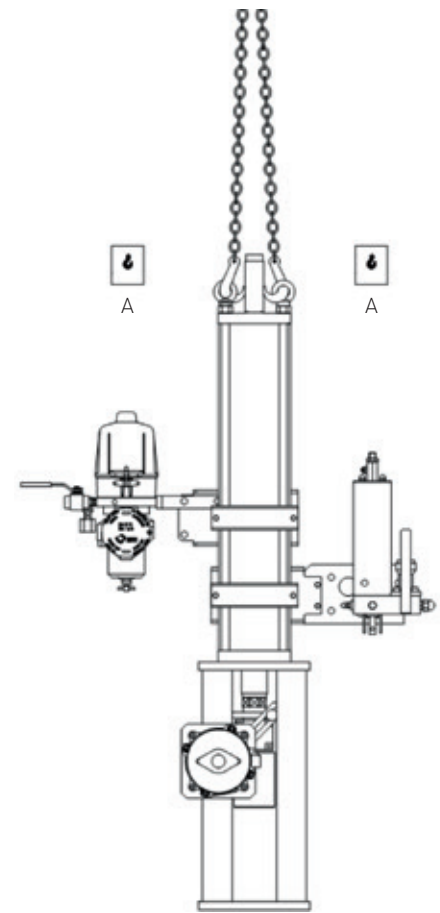

A = Lifting eyelet

FIGURE 4  
Positioning by chains / Positioning by slings

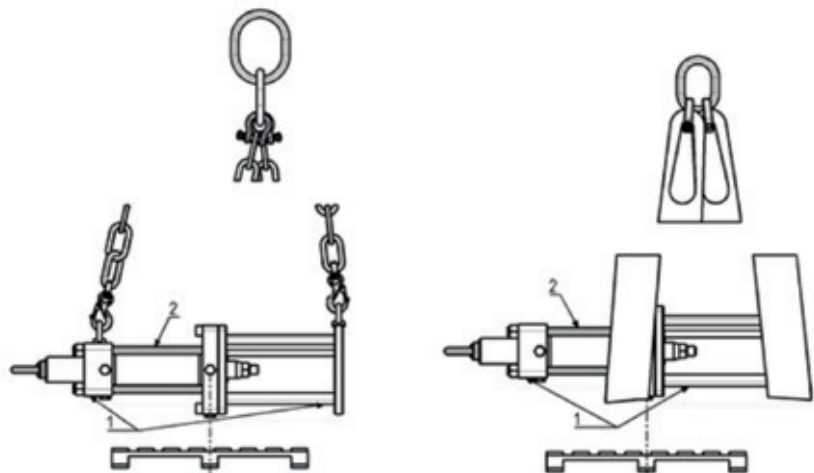

1. Point of support
2. Do not lay the actuator on cylinder tie-rods
3. Do not lay the actuator on accessories (manual hand pump, pneumatic control system etc.)

# GIL DOUBLE ACTING DIRECT GAS LINEAR ACTUATOR

## INSTALLATION, OPERATION AND MAINTENANCE MANUAL

### 2.4.2 Assembly procedure

#### WARNING

Failure to comply with the following procedures may impair product warranty. Installation, commissioning, maintenance and repair works should be carried out by qualified staff. A non-conforming assembly could be the source of serious accidents.

For actuator assembly on the valve:

- Check that the assembly position, as shown on the documentation, complies with system's geometry.
- Check the consistency of the actuator-valve coupling's parts.

#### A. To assemble the actuator onto the valve by bracket with threaded joint proceed as follows:

1. Check that the coupling dimensions of the valve flange and stem, or of the relevant extension, meet the actuator coupling dimensions (valve stem and flange). Lubricate the valve stem with grease in order to make the assembly easier.

2. Connect a sling to the support point of the actuator and lift it. To make assembly easier, the valve stem has to be in a perfect vertical position. **Note:** the eyebolt is sized for the lifting of the actuator only (not actuator+valve). Proper lifting points have to be provided for the valve.
3. Screw the actuator coupling joint onto the valve by rotating the actuator, or screw down the valve stem stroke-ring with Red Loctite 542 and fix the half-bearings. When the threaded holes of the actuator flange correspond with the holes on the valve flange, screw the proper stud bolts. Screw the nuts on the stud bolts and tighten up the valve flange until it is in contact with the actuator flange.
4. Tighten the nuts of the connecting stud bolts evenly with the torque prescribed in table 1. The stud bolts must be made of ASTM A320 L7 steel, the nuts must be made of ASTM A194 grade 2 steel as minimum.

FIGURE 5  
Pedestal with threaded coupling joint

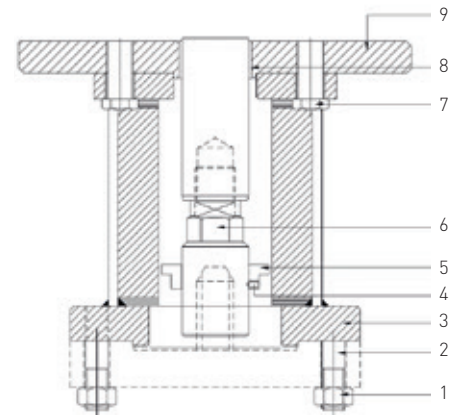

#### PARTS LIST

Item	Description
1	Nut
2	Stud bolt
3	Support joint
4	Index
5	Screw
6	Connecting joint
7	Screw
8	Bushing
9	Flange

# GIL DOUBLE ACTING DIRECT GAS LINEAR ACTUATOR

## INSTALLATION, OPERATION AND MAINTENANCE MANUAL

### B. To assemble the actuator onto the valve by bracket with shell joint, perform the following operations:

1. Check that the coupling dimensions of the valve flange and stem, or of the relevant extension, meet the actuator coupling dimensions (valve stem and flange). Lubricate the valve stem with grease in order to make the assembly easier.
2. To make assembly easier, the valve stem has to be in a perfect vertical position.
3. Disassemble the two halves of actuator pedestal shell joint (item 8) by unscrewing the retaining screws (item 4), then disassemble the valve stem joint (item 7).
4. Lift the actuator by utilizing the proper lifting eyelets and unscrew the nuts and the stud bolts from the actuator pedestal.

5. Assemble the actuator onto the valve and arrange it in its correct vertical position to enable proper connection between valve stem and actuator cylinder rod.
6. Screw the valve stem joint (item 7) on the valve stem up to reach the proper position which allows the reassembly of the two halves of shell joint (item 8). Tighten the joint fastening screws (item 4).
7. Screw the stud bolts (item 1) into the actuator pedestal flange, and screw the nuts on the stud bolts.
8. Tighten according to the nut (item 2) size torque requirements shown in table 1.

The tightening values in table 1 were calculated for materials ASTM A320 L7 for screws or tie rods and ASTM A194 gr.2H for the nuts.

FIGURE 6  
Pedestal with shell coupling joint

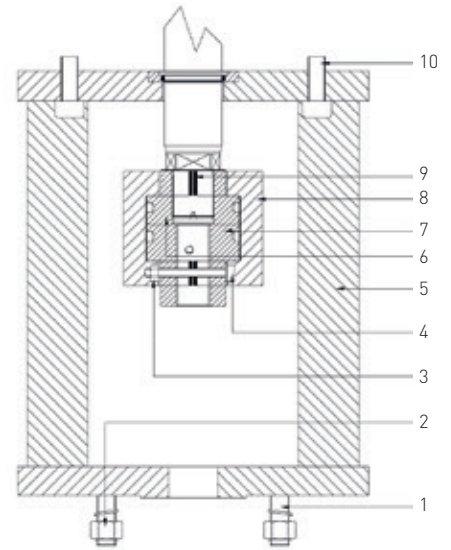

### PARTS LIST

Item	Description
1	Stud bolt
2	Nut
3	Nut
4	Screw
5	Pedestal
6	Actuator joint
7	Stem valve joint
8	Shell joint
9	Spacer
10	Screw

To implement, refer to the following table:

TABLE 1 - NUTS TIGHTENING TORQUE

Threading	Tightening torque (Nm)
M8	20
M10	40
M12	70
M14	110
M16	160
M20	320
M22	420
M24	550
M27	800
M30	1100
M33	1400
M36	1700

# GIL DOUBLE ACTING DIRECT GAS LINEAR ACTUATOR

## INSTALLATION, OPERATION AND MAINTENANCE MANUAL

### 2.5 Pneumatic connections

#### WARNING

Check that the values of pneumatic supply available are compatible with those reported on the actuator identification plate.

#### IMPORTANT

The connections should be made by qualified staff. Use pipes and connections appropriate for type, material and dimensions.

- Deburr the ends of rigid pipes properly
- Clean the interior of pipes properly, sending through them plenty of the supply fluid used in the system.
- Mould and fasten the connection pipes so that no irregular strains at entries or loosening of threaded connections occur.
- Make the connections according to the operating diagram.
- Check the absence of leakages from pneumatic connections.

### 2.6 Electrical connections (if any)

#### WARNING

Use components appropriate for type, material and dimensions.  
The connections should be made by qualified staff. Before carrying out any operation, cut line power off.

#### IMPORTANT

Safety provisions:  
2006/95/EC: Directive for low voltage equipment.  
2004/108/EC: Directive for the electromagnetic compatibility.  
94/9/EC: Directive and safety instructions for use in hazardous area

Remove plastic plugs from cables entries

- Screw the cable glands firmly.
- Introduce connection cables.
- Make the connections in compliance with applicable wiring diagrams on the documentation supplied.
- Screw the cable gland.
- Replace the plastic plugs of unused entries.

### 2.7 Commissioning

#### WARNING

Installation, commissioning, maintenance and repair works should be carried out by qualified staff.

Upon actuator commissioning please carry out the following checks:

- Check that paint has not been damaged during transport. If necessary, repair damage to the paint coat.
- Check that the pressure and quality of the gas supply (filtering degree, dehydration) are as prescribed. Check that the feed voltage values of the electric components (solenoid valve coils, microswitches, pressure switches, etc.) are compatible with those reported on the identification plate of the actuator (figure 1).
- Check that the setting of the actuator control unit's components (pressure regulator, pressure switches, flow control valves, etc.) meet the plant requirements.
- Carry out all kinds of operations and check their proper execution (section 3.3).
- Check the absence of leakages in the pneumatic connections. If necessary tighten the nuts of the pipe-fittings.
- Check proper operation of all the due signalling (valve position, gas supply pressure etc.).
- Make a complete functional test in order to verify all the operations are executed according to operating schematic diagram supplied.



FIGURE 7  
Junction box on control group (if foreseen)

# GIL DOUBLE ACTING DIRECT GAS LINEAR ACTUATOR

## INSTALLATION, OPERATION AND MAINTENANCE MANUAL

### 3 OPERATION AND USE

#### 3.1 Operation description

The supply gas pressurizes the pneumatic-cylinder chamber relevant to the operation to be carried out (opening or closing) (see following pages).

This pressure starts the linear motion of the piston and the consequent motion of the valve stem that is coupled.

For local or remote operations, please refer to the technical documentation furnished with the actuators.

The power and control systems are supplied on specific customer demand.

#### WARNING

For all the relevant information please refer to the specific documentation supplied.

#### 3.2 Residual risks

#### WARNING

It is recommended to pipe exhaust gas.

The actuator has parts under pressure.

Use due caution.

Use individual protections provided for by the laws and provisions in force.

#### 3.3 Operations

#### WARNING

Use the proper safety measures to protect from any pressurized gas not piped and from excessive and harmful noise. Refer to applicable control schematic in supplied documentation.

FIGURE 8

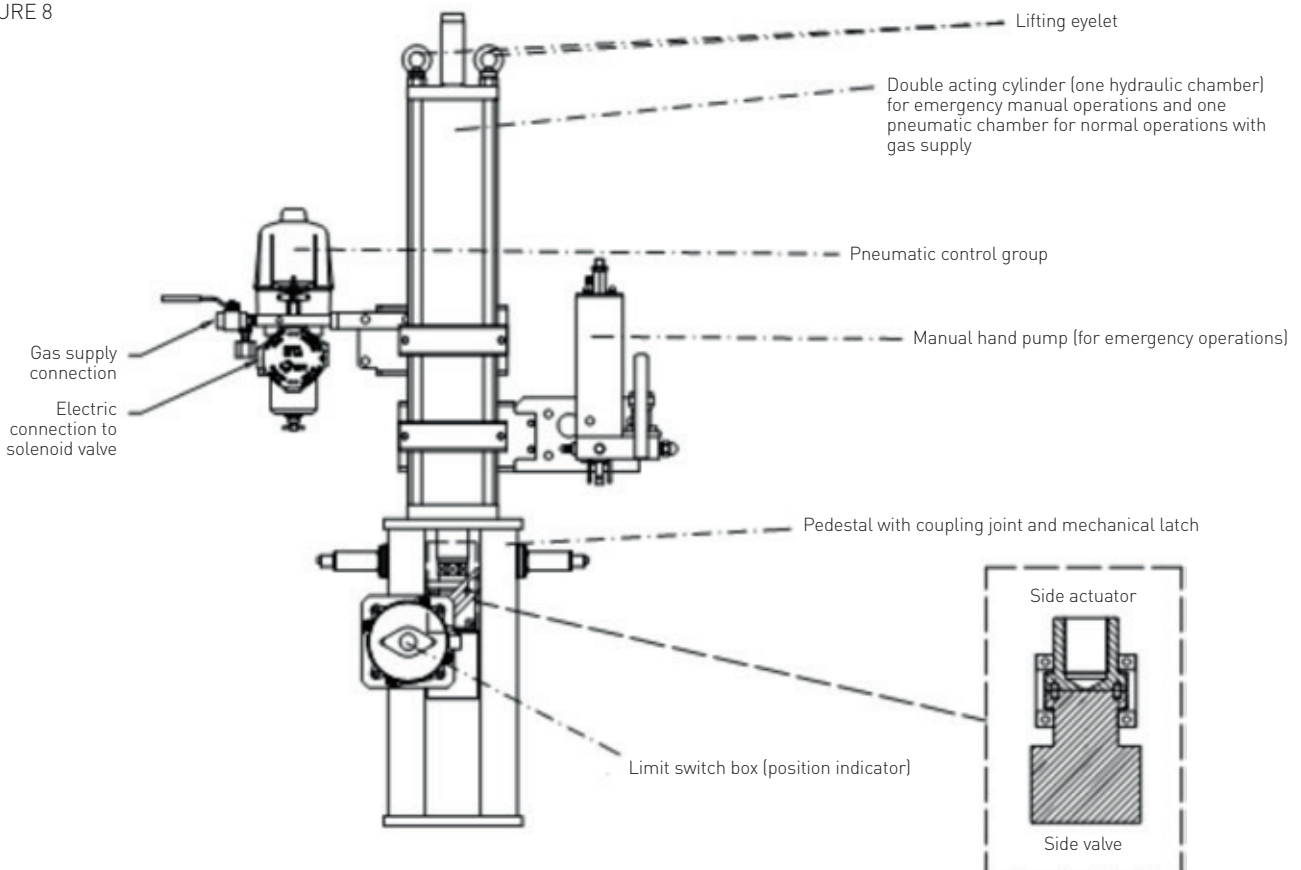

# GIL DOUBLE ACTING DIRECT GAS LINEAR ACTUATOR

## INSTALLATION, OPERATION AND MAINTENANCE MANUAL

FIGURE 9  
 GIL - Typical operating diagram

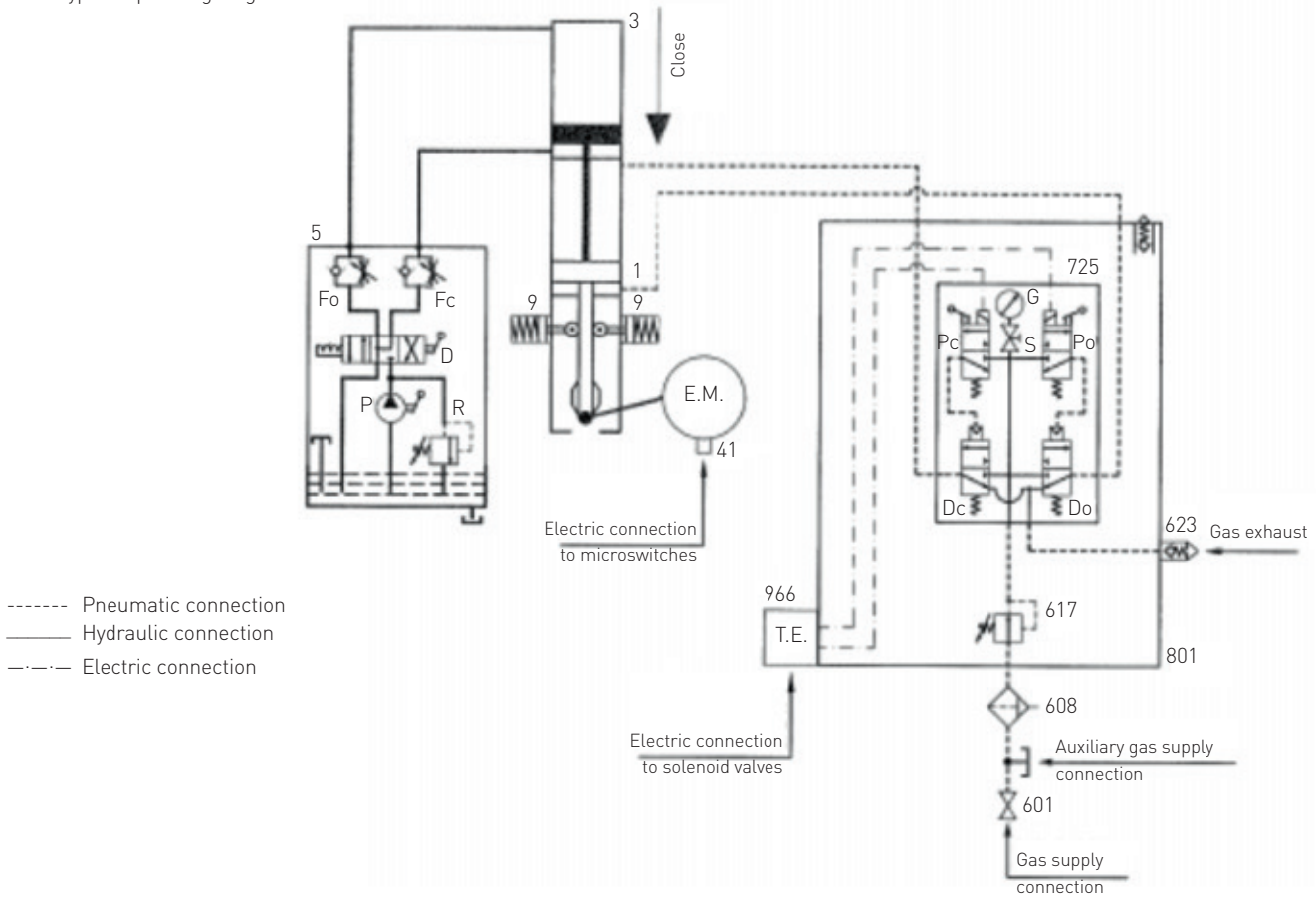

### Electric remote control to open and to close

Energize the solenoid valve 725-Po to open or 725-Pc to close, during the complete actuator stroke.

### Local control to open and to close

Press the lever on valve 725-Po to open or 725-Pc to close, during the complete actuator stroke.

### Locking in open position

When the actuator operations are not controlled, the actuator is kept in fully open position by the mechanical latches 9. Move the actuator to close position by electric remote, local control or emergency control operation.

### Emergency manual operation

Select by the valve '5-D' the opening or closing operation and actuate the hand pump '5-P'. Note: the valve '5-D' must be in remote control position to allow the operation with gas supply.

### NOTE

The operating diagram is drawn with solenoid valves coils not energized.

### PARTS LIST

Item	Description
1	Double acting pneumatic linear actuator
3	Hydraulic cylinder
5	Manual override
	R - Relief valve
	P - Hand pump
	D - Hand operated directional control valve
	Fo - Unidirectional flow regulator (opening operation)
	Fc - Unidirectional flow regulator (closing operation)
9	Mechanical latch with pneumatic and hydraulic pilots
41	Electric microswitches
601	Stop valve
608	Gas filter/condensate separator
617	Pressure regulator
623	Dust excluder with check valve
725	Double 3/2 N.C. Solenoid valve with manual override:
	Pc - 3/2 N.C. Pil. Solenoid valve with manual override (to close)
	Po - 3/2 N.C. Pil. Solenoid valve with manual override (to open)
	Dc - 3/2 N.C. Pneumatic pilot/spring return valve (to close)
	Do - 3/2 N.C. Pneumatic pilot/spring return valve (to open)
	S - Needle valve
	G - Pressure gauge
801	Control valves enclosure with vent valve
966	Terminals enclosure

# GIL DOUBLE ACTING DIRECT GAS LINEAR ACTUATOR

## INSTALLATION, OPERATION AND MAINTENANCE MANUAL

FIGURE 10  
Double solenoid valve with manual control



### 3.3.1 Local pneumatic operation

#### WARNING

Use the proper safety measures to protect from any pressurized gas not piped and from excessive and harmful noise.

- Operate the manual control lever of the double solenoid valve in the control group, relevant to the operation to carry out (opening or closing) (figure 9), press the lever during the complete actuator stroke.
- Check the correct operation of the actuator through the visual position indicator.
- Release the lever to terminate the operation.

### 3.3.2 Electric remote control to open and to close

- From the control room send the electric signal corresponding to the operation to carry out: energize solenoid valve 725-Po to open or 725-Pc to close the actuator, during all the valve stroke.
- Solenoid valves must be de-energized at the end of actuator operation.

### 3.3.3 Emergency manual operation

(when sufficient line pressure is not available)

- Select by the valve 5-D the opening or closing operation.
- Actuated the pump 5-P until to reach the complete operation.
- Check the correct operation of the actuator through the visual position indicator.
- Close the stop valves 351 to keep the actuator in position.



#### WARNING

If no other manual operation is carried out, the valve 5-D must be in 'remote control' position and the stop valve 351 must be open to allow the operation with gas supply. (see section 7.2 figure 27: sectional drawing for hydraulic control unit MHP).

### 3.3.4 Locking in open position

When the actuator operations are not controlled, the actuator is kept in fully open position by the mechanical latches 9. Move the actuator to close position by electric remote, local control or emergency manual operation.

### 3.4 Calibration of the linear stroke

It is important that the mechanical stops of the actuator (and not those of the valve) stop the linear stroke at both extreme valve position (fully open and fully closed), except when this is required by the valve operation).

The setting of the open/closed valve position (upward position) is performed by adjusting the travel stop screw into the end flange of the pneumatic cylinder and by the adjustment of the coupling of valve stem to actuator joint for the downward position.

For the adjustment of the travel stop screws proceed as follows:

- 1) Unscrew the plug from the "adjusting screw cover".
- 2) If the actuator linear stroke is stopped before reaching the upward position (fully open or closed), unscrew the adjusting screw by turning it anticlockwise with a proper wrench, until the valve reaches the right position. When unscrewing the adjustable screw, keep the "adjusting screw cover" still with a wrench so it does not withdraw together with the screw.
- 3) If the actuator linear stroke is stopped beyond the upward position (fully open or closed valve), screw the stop screw by turning it clockwise until the valve reaches the right position.
- 4) Screw the plug into the "adjustable screw cover".

FIGURE 11  
Mechanical stop



# GIL DOUBLE ACTING DIRECT GAS LINEAR ACTUATOR

## INSTALLATION, OPERATION AND MAINTENANCE MANUAL

For the adjustment of the mechanical stop on the end flange of cylinder, follow these steps (refer to figure 12):

- Remove the plug (t) with the specific wrench (c1).
- Insert a wrench for Allen keys (c2) in the through hole until you reach the adjustment pin (g).
- Keep the protection cover blocked with the special wrench (c3).
- Turn counter-clockwise to increase the angular stroke, turn clockwise to decrease it.
- When the adjustment is complete, tighten the plug (t).

FIGURE 12  
Mechanical stop of the cylinder

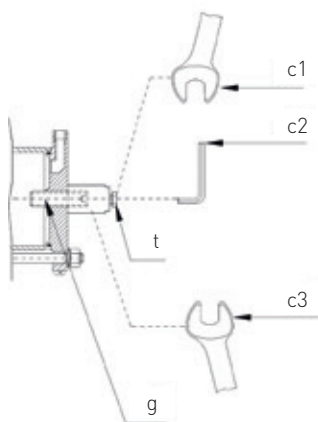

Cylinder size	Wrench c1 (mm)	Wrench c2 (mm)	Wrench c3 (mm)
075	22	10	36
100	22	10	36
135	22	10	36
175	22	14	46
200	27	14	46
235	27	17	65
280	27	17	65
300	36	17	110

# GIL DOUBLE ACTING DIRECT GAS LINEAR ACTUATOR

## INSTALLATION, OPERATION AND MAINTENANCE MANUAL

### 3.5 Calibration of microswitches (with safety instructions for limit switch box)

If the actuator is delivered separately from the valve, it is necessary to check, and, if required, to adjust, the settings of the position signalling microswitches.

#### IMPORTANT

Operate only the microswitch corresponding to the direction of operation being carried out, as clearly reported on the microswitch.

#### WARNING

If microswitches assembly or limit switch box is supplied, please refer to the specific technical documentation.

#### IMPORTANT

End of stroke microswitches should be operated before the stop of the stroke of the actuator due to mechanical stops. Adjust the relative cams properly.

#### WARNING

Do not open when energized or when an explosive atmosphere is present.

#### WARNING

Electrostatic hazard, clean only with damp cloth.

#### 3.5.1 Westlock 2200 Series Quantum - ATEX certified

EPSILON 08 ATEX 2370X

Ex d IIB +H2 T\* Tamb -°C to +°C

Ex tD A21 IP6X T\*°C Tamb -°C to +°C

Flat cover -20°C to +85°C (T4); -20°C to +75°C (T5); -20°C to +60°C (T6)

Beacon cover -30°C to +85°C (T4); -30°C to +75°C (T5); -30°C to +60°C (T6)

Environmental parameters: 80 kPa (0.8 bar) to 110 kPa (1.1 bar). Air with normal oxygen content, typically 21%.

#### The 2200 certification is compliant against the following standards

EN 60079-0 : 2006	Electrical apparatus for explosive gas atmospheres – Part 0 - General requirements
EN 60079-1 : 2007	Electrical apparatus for explosive gas atmospheres – Part 1 - Flameproof enclosures 'd'
EN 61241-0 : 2006	Electrical apparatus for use in the presence of combustible dust – Part 0 - General requirements
EN 61241-1 : 2006	Electrical apparatus for use in the presence of combustible dust – Part 1 - Protection by enclosures 'tD'

#### 3.5.1.1 Product description

The 2200 series valve control monitor provides two methods of end of travel indication by the means of mechanical switches, inductive proximity sensors or proximity switches and an external visual indicator.

For applications that require position feed back, ancillary components such as a 4-20 mA current signal transmitter or a resistive signal feed back can be installed.

To allow this product to be used with network communication bus protocols, the 2200 series enclosure can house various network modules. The 2200 series enclosure comprises of a two parts, a cover and housing. The cover has three variations, flat cover, standard beacon cover or a high cover to suit different applications. The housing can offer up to two integral solenoid coils and upto three of the following conduit entries; M20 x 1.5p, M25 x 1.5p, 1/2"-14 NPT or 3/4"-14 NPT cable entries for connection to an external power source via appropriate ATEX certified cable glands.

**Note:** Before installation of this product, please ensure that the product and its certification is suitable for the intended application. This product uses various 'O'-ring material and an Eastar Copolyester visual indicator.

If the equipment is likely to come into contact with aggressive substances, then it is the responsibility of the user to take suitable precautions that prevent it from being adversely affected, thus ensuring that the type of protection provided by the equipment is not compromised.

Installation of any cable entry devices, conduit entry devices or blanking devices shall not compromise the degree of ingress protection level IP6X for use in the presence of combustible dusts.

The unit has an ingress protection of IP66/67 and therefore any conduit device fitted must maintain this.

**Note:** These products have been certified with a cable entry temperature rise of 4°C. Ensure that this is taken into consideration when selecting suitable cabling for the ambient temperature in which the product is to be used.

**Note:** These products are not intended to be assembled directly to process pipe work etc that is heated or cooled to temperatures outside of the range as indicated above.

# GIL DOUBLE ACTING DIRECT GAS LINEAR ACTUATOR

## INSTALLATION, OPERATION AND MAINTENANCE MANUAL

### 3.5.1.2 Mounting instructions

- 1) Attach the mounting bracket and adaptor (if required) to the Quantum housing and shaft with the fasteners provided with the mounting kit.
- 2) To ensure that the 2200 series Quantum is mounted correctly, it may be necessary to stroke the actuator to the fully closed position.

#### WARNING

Before stroking the actuator to the fully closed position, please ensure that the process is safe to do so.

- 3) With the actuator in the correct position, attach the 2200 series Quantum / bracket to the actuator using the hardware provided in the mounting kit.
- 4) To release the cover, loosen the cover retaining screws. Twist the cover approx 45° and lift up. See figure 13.
- 5) To set the switches, lift the bottom cam and turn until the switch has activated and then release. The spring will push the cam back onto the splined shaft.

#### WARNING

Before stroking the actuator, please ensure that the process is safe to do so and that all hands are kept away from the moving shaft.

- 6) Stroke the actuator to the opposite end of travel. Set the top cam by pushing down and turning the cam until the switch is activated.

#### WARNING

Before stroking the actuator, please ensure that the process is safe to do so and that all hands are kept away from the moving shaft.

- 7) Stroke the actuator from one end of stroke to the other several times to check the switch operation. If the switches require adjustment, repeat steps 5) to 7).

### 3.5.1.3 Field wiring and installation

#### WARNING

The 2200 series should always be handled with care when the cover is removed and wired to electrical power source.

**NOTE:** Before electrical installation, please read and follow the wiring diagram located inside the cover. The electrical ratings can be found on the product I.D label.

- 1) Field wiring must be carried out in accordance with site, local and national electrical codes / requirements. This includes special attention to earth bond to the aluminium enclosure using the internal and external earth points provided.

- 2) Installation of this product shall be carried out by competent personnel in accordance with the applicable code of practice such as EN 60079-14.
- 3) The 2200 control monitor housing can offer up to three of the following conduit entries; M20 x 1.5p, M25 x 1.5p, 1/2" - 14 NPT or 3/4" - 14 NPT. These entries are detailed on the product I.D label found on the product cover. Please see figure 15 for conduit positions.

FIGURE 13

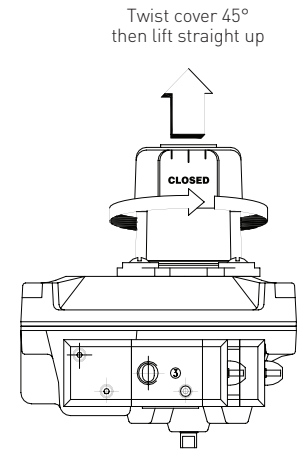

FIGURE 14

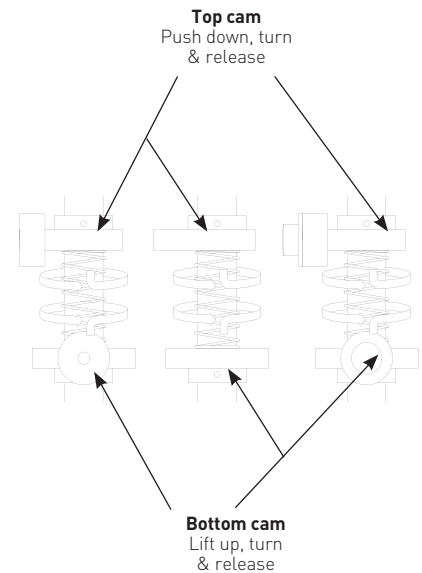
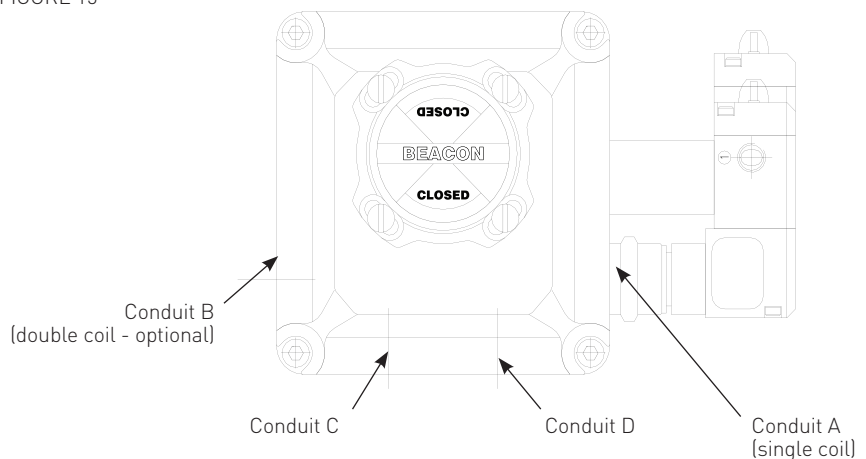

FIGURE 15



# GIL DOUBLE ACTING DIRECT GAS LINEAR ACTUATOR

## INSTALLATION, OPERATION AND MAINTENANCE MANUAL

- 4) The certification applies to equipment without cable glands. When mounting the flameproof enclosure in the hazardous area, only suitably rated IP66/67 ATEX certified flameproof glands must be used.
- 5) All unused cable entries must be plugged with a suitably rated IP66/67 ATEX certified blanking devices.
- 6) The first two digits of the Westlock nomenclature signifies the series with the third digit defining whether the product has a visual beacon or not. The table below details the applicable ambient ranges:

Series code	Cover type	T class	Ambient range
224*	Beacon	T6 (80°C)	-30°C to +60°C
224*	Beacon	T5 (95°C)	-30°C to +75°C
224*	Beacon	T4 (130°C)	-30°C to +85°C
226*	Flat	T6 (80°C)	-20°C to +60°C
226*	Flat	T5 (95°C)	-20°C to +75°C
226*	Flat	T4 (130°C)	-20°C to +85°C

- 7) The fourth digit designates the switch / sensor type. The following table details the most common switch / sensor types together with their electrical ratings.

Series code/Switch designation	Electrical rating
22*5 Mechanical (SPDT)	15 A - 125 or 250 V AC; 0.5 A - 125 V DC; 0.25 A - 250 V DC
22*6 Mechanical (DPDT)	10 A - 125 or 250 V AC; 10 A - 28 V DC; 0.2 A - 125 V DC
22*7 Inductive proximity sensors	
22*9 Magnum ratings	3 A - 120 V AC; 1.5 A - 240 V AC or 2 A - 24 V DC

**NOTE:** The series code signifies the maximum electrical rating of the product, suitable overloading protection must be provided to prevent these values being exceeded.

- 8) The 2200 series valve position monitor has the option for position feedback by the means of a resistive signal (RS) or current signal (CS).  
The RS transmitter electrical ratings are – 1 k ohms (standard) or 5 k ohms (optional). See I.O.M TECH-084.  
The CS transmitter electrical ratings are – current loop 4-20 mA at 18 to 24 V DC. See I.O.M TECHUK-301
- 9) The 2200 series valve control monitor has the ability to connect to bus networks via Netpak modules. With the Netpak options it may be possible to assemble other switches within the enclosure (depending on enclosure cover variation).

### 9.1) Netpak electrical parameters.

Netpak option	Electrical parameters	I.O.M.
AS-I Actuator Sensor Interface	24 V DC, 140 mA MAX	TECH-316
Device Net	24 V DC, 105 mA MAX	TECH-309
Modbus	24 V DC, 85 mA MAX	TECH-214
Profibus DP	24 V DC, 120 mA MAX	TECH-326
Foundation Fieldbus	9-32 V DC, 34 mA MAX	TECH-485

- 10) Digit 10 of the Westlock nomenclature signifies the coil voltage with the following voltage and type available, 24, 48, 110 and 240 V AC or V DC.
- 11) Before replace the enclosure cover, ensure that both of the housing and cover flange surfaces are clean and undamaged. Tighten the cover screws hand tight using a standard 6 mm A/F Allen key ensuring there are no gaps.

### 3.5.1.4 Product repair and service

- 1) Inspection of this product shall be carried out by suitably trained personnel in accordance with the applicable code of practice such as EN 60079-17.
- 2) In the event of any repairs that may be required such tasks must be carried out by suitably trained / competent personnel in accordance with the applicable code of practice such as EN 60079-19.
- 3) The certification of this product has been approved based on the material of construction as per the drawings listed in the schedule within this certificate. Any replacement parts that are not made in accordance to the listed drawing will invalidate the approval / certification.
- 4) Replacement parts must be purchased through Westlock Controls UK Ltd or via an approved Westlock Controls distributor.

# GIL DOUBLE ACTING DIRECT GAS LINEAR ACTUATOR

## INSTALLATION, OPERATION AND MAINTENANCE MANUAL

### 3.5.2 Westlock 2600 Series - ATEX certified

ITS 11 ATEX 17438X

Ex d IIC Gb T\* Tamb -\*°C to +\*°C

Ex tb IIIC Db T\*°C Tamb -\*°C to +\*°C IP6X

Ambient variation: -60°C to +110°C (T4/T130°C); -60°C to +85°C (T5/T95°C);

-60°C to +65°C (T6/T80°C)

Environmental parameters: 80 kPa (0.8 bar) to 110 kPa (1.1 bar). Air with normal oxygen content, typically 21%.

#### The 2600 certification is compliant against the following standards

EN 60079-0 : 2011 (Ed 6)	Electrical apparatus for explosive gas atmospheres – Part 0 - General requirements
EN 60079-1 : 2007	Electrical apparatus for explosive gas atmospheres – Part 1 - Flameproof enclosures 'd'
EN 60079-31 : 2009	Electrical apparatus for use in the presence of combustible dust – Part 31 - Protection by enclosure 't'

#### 3.5.2.1 Product description

The 2600 series valve control monitor provides two methods of end of travel indication by the means of mechanical switches, inductive proximity sensors or proximity switches and an external visual indicator.

For applications that require position feed back, ancillary components such as a 4-20 mA current signal transmitter or a resistive signal feed back can be installed.

The 2600 series enclosure is available in two materials; cast aluminium or 316 stainless steel. The enclosure construction comprises of a housing with a screwed cover.

The housing has the option of upto three cable entries for connection to an external power source via appropriate ATEX certified cable glands: M20 x 1.5p, M25 x 1.5p, ½" - 14 NPT or ¾" - 14 NPT.

**Note:** Before installation of this product, please ensure that the product and its certification is suitable for the intended application. This product uses various 'O'-ring material and an Eastar Copolyester visual indicator.

If the equipment is likely to come into contact with aggressive substances, then it is the responsibility of the user to take suitable precautions that prevent it from being adversely affected, thus ensuring that the type of protection provided by the equipment is not compromised.

Installation of any cable entry devices, conduit entry devices or blanking devices shall not compromise the degree of ingress protection level IP6X for use in the presence of combustible dusts.

The unit has an ingress protection of IP66/67 and therefore any conduit device fitted must maintain this.

**Note:** These products have been certified with a cable entry temperature rise of 4°C. Ensure that this is taken into consideration when selecting suitable cabling for the ambient temperature in which the product is to be used.

**Note:** These products are not intended to be assembled directly to process pipe work etc that is heated or cooled to temperatures outside of the range as indicated above.

#### WARNING

*Do not open when energized or when an explosive atmosphere is present.*

#### WARNING

*Electrostatic hazard, clean only with damp cloth.*

#### 3.5.2.2 Mounting instructions

- 1) Attach a mounting bracket to the housing base with the M8 fasteners provided with the mounting bracket. Install shaft adaptor / coupler, as appropriate to either the actuator pinion or Accutrak shaft.
- 2) To ensure that the 2600 series Accutrak is mounted correctly, it may necessary to stroke the actuator to the fully closed position.

#### WARNING

*Before stroking the actuator to the fully closed position, please ensure that the process is safe to do so.*

- 3) With the actuator in the correct position, attach the 2600 series Accutrak / bracket to the actuator using the hardware provided in the mounting kit.
- 4) Unscrew the cover (figure 16) and keep in a safe place. Ensure that the Jack screw (M4 socket head cap screw) remains in the housing (figure 17).
- 5) To set the switches, lift the bottom cam and turn until the switch has activated and then release. The spring will push the cam back onto the splined shaft (figure 18).

#### WARNING

*Before stroking the actuator, please ensure that the process is safe to do so and that all hands are kept away from the moving shaft.*

- 6) Stroke the actuator to the opposite end of travel. Set the top cam by pushing down and turning the cam until the switch is activated.

#### WARNING

*Before stroking the actuator, please ensure that the process is safe to do so and that all hands are kept away from the moving shaft.*

- 7) Stroke the actuator from one end of stroke to the other several times to check the switch operation. If the switches require adjustment, repeat steps 5) to 7).
- 8) Beacon setting – if fitted. Loosen the beacon fixing screw, see figures 16 and 17, rotate beacon window (outer beacon) to indicate appropriate open or closed text as corresponding to actuator position.
- 9) Tighten beacon fixing screw sufficiently to prevent movement of window.

# GIL DOUBLE ACTING DIRECT GAS LINEAR ACTUATOR

## INSTALLATION, OPERATION AND MAINTENANCE MANUAL

### 3.5.2.3 Field wiring and installation

#### WARNING

The 2600 series should always be handled with care when the cover is removed and wired to electrical power source.

**NOTE:** Before electrical installation, please read and follow the wiring diagram located inside the cover. The electrical ratings can be found on the product I.D label.

- 1) Field wiring must be carried out in accordance with site, local and national electrical codes / requirements. This includes special attention to earth bond to the aluminium enclosure using the internal and external earth points provided.
- 2) Installation of this product shall be carried out by competent personnel in accordance with the applicable code of practice such as EN 60079-14.
- 3) The 2600 control monitor housing can offer up to three of the following conduit entries; M20 x 1.5p, M25 x 1.5p, 1/2" - 14 NPT or 3/4" - 14 NPT. These entries are detailed on the product I.D label found on the product cover. Please see figure 19 for conduit positions.

FIGURE 16  
Standard enclosure

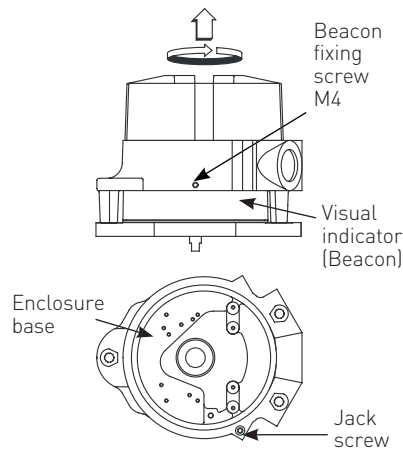

FIGURE 17  
Alternative enclosure

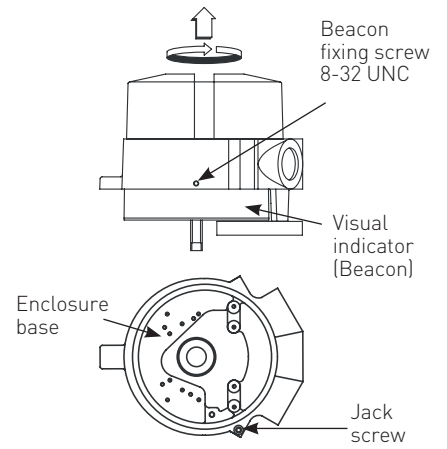

FIGURE 18

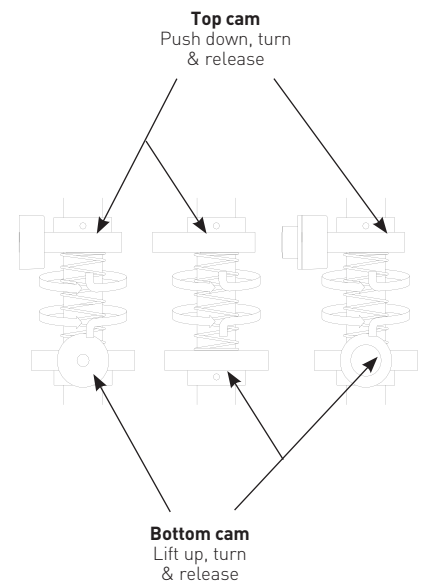
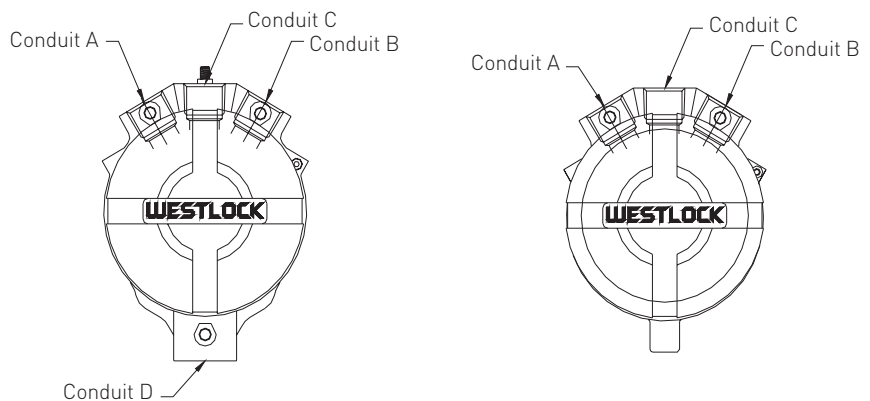

FIGURE 19  
2600 conduit designations (alternative enclosure)



# GIL DOUBLE ACTING DIRECT GAS LINEAR ACTUATOR

## INSTALLATION, OPERATION AND MAINTENANCE MANUAL

- 4) The certification applies to equipment without cable glands. When mounting the flameproof enclosure in the hazardous area, only suitably rated IP66/67 ATEX certified flameproof glands must be used.
- 5) All unused cable entries must be plugged with a suitably rated IP66/67 ATEX certified blanking devices.
- 6) Thread adaptors shall satisfy the requirements of the specific type of protection.
- 7) The first two digits of the Westlock nomenclature signifies the series with the third digit defining whether the product has a visual beacon or not. The table below details the applicable ambient ranges:

Series code	Cover type	T class	Ambient range
264*	Beacon	T6 (80°C)	-60°C to +65°C
264*	Beacon	T5 (95°C)	-60°C to +80°C
264*	Beacon	T4 (130°C)	-60°C to +110°C
266*	No beacon	T6 (80°C)	-60°C to +65°C
266*	No beacon	T5 (95°C)	-60°C to +80°C
266*	No beacon	T4 (130°C)	-60°C to +110°C

- 8) The fourth digit designates the switch / sensor type. The following table details the most common switch / sensor types together with their electrical ratings.

Series code/Switch designation	Electrical rating
26*5 Mechanical (SPDT)	15 A - 125 or 250 V AC; 0.5 A - 125 V DC; 0.25 A - 250 V DC
26*6 Mechanical (DPDT)	10 A - 125 or 250 V AC; 10 A - 28 V DC; 0.2 A - 125 V DC
26*7 Inductive proximity sensors	
26*9 Magnum ratings	3 A - 120 V AC; 1.5 A - 240 V AC or 2 A - 24 V DC

**NOTE:** The series code signifies the maximum electrical rating of the product, suitable overloading protection must be provided to prevent these values being exceeded.

- 9) The 2600 series valve position monitor has the option for position feedback by the means of a resistive signal (RS) or current signal (CS).  
The RS transmitter electrical ratings are – 1 k ohms (standard) or 5 k ohms (optional). See I.O.M TECH-084.  
The CS transmitter electrical ratings are – current loop 4-20 mA at 18 to 24 V DC. See I.O.M TECHUK-301
- 10) Before replacing the enclosure cover, ensure that both of the housing and cover threads are clean and undamaged. Screw the cover onto the housing ensuring that it is not cross threaded and turns freely. Continue tightening the cover until metal to metal condition is achieved between the bottom edge of the cover and the housing surface.  
Lock the cover as follows:  
Using a 3mm A/F Allen key / wrench, rotate the Jack screw in an anti-clockwise direction until sufficient pressure has been applied to the bottom edge of the cover to prevent the cover from being removed by hand.

### 3.5.2.4 Product repair and service

- 1) Inspection of this product shall be carried out by suitably trained personnel in accordance with the applicable code of practice such as EN 60079-17.
- 2) In the event of any repairs that may be required such tasks must be carried out by suitably trained / competent personnel in accordance with the applicable code of practice such as EN 60079-19.
- 3) The certification of this product has been approved based on the material of construction as per the drawings listed in the schedule within this certificate. Any replacement parts that are not made in accordance to the listed drawing will invalidate the approval / certification.
- 4) Replacement parts must be purchased through Westlock Controls UK Ltd or via an approved Westlock Controls distributor.

# GIL DOUBLE ACTING DIRECT GAS LINEAR ACTUATOR

## INSTALLATION, OPERATION AND MAINTENANCE MANUAL

### 3.5.3 Westlock 3000 Series - ATEX certified

SIRA 05 ATEX 2242X

II 1 G Ex ia II\* T\* G\*

II 1 D Ex ia IIIC T120°C Da IP6X

\* variables based on construction and internal components.

Ta = -20°C to +40°C (plastic enclosure),

Ta = -40°C to +60°C (metal enclosure, subject to limitations of installed devices)

#### The 3000 certification is compliant against the following standards

EN 60079-0 : 2009	Explosive atmospheres. Equipment. General requirements
EN 60079-11 : 2007	Electrical apparatus for explosive gas atmospheres – Part 11 - Intrinsic Safety 'i'
EN 60079-26 : 2007	Explosive atmospheres. Equipment with equipment protection level (EPL) Ga
IEC 61241-0 : 2004	Electrical apparatus for use in the presence of combustible dust – General requirements
IEC 61241-11 : 2005	Electrical apparatus for use in the presence of combustible dust – Protection by intrinsic safety 'iD'

#### 3.5.3.1 Product description

The equipment may be used in a CAT 1,2 or 3 environment (internal component dependant) in the presence of flammable gases / vapours and dusts. The apparatus groups cover IIA, IIB and IIC (internal component dependant) with temperature classes of T1 through to T4 or either T5 or T6 internal component dependant. The maximum ambient temperature range is -40 to +60°C (dependant on enclosure material and internal components).

The 3000 series valve position monitor provides end of travel indication by the means of either electrical switch or inductive sensors mounted within the enclosure. These are activated by cams mounted on the rotary shaft.

The 3000 series enclosure construction comprises of a shaft passing through the enclosure base and cover (when fitted with visual beacon). The two part enclosure has an integral gasket seal. The shaft has up to two 'O'ring seals in both the cover and housing bearings. This product is available in three materials, Zytel resin, aluminium or stainless steel 316.

The housing has the option of up to three cable entries (dependant on enclosure material) for connection to an external power source via appropriate ATEX certified cable glands; M20 x 1.5p, M25 x 1.5p, 1/2" - 14NPT, 3/4" - 14 NPT, PG13.5 or any other suitable thread that can maintain IP6X ingress rating.

**Note:** Before installation of this product, please ensure that the product and its certification is suitable for the intended application.

If the equipment is likely to come into contact with aggressive substances, then it is the responsibility of the user to take suitable precautions that prevent it from being adversely affected, thus ensuring that the type of

protection provided by the equipment is not compromised.

Installation of any cable entry devices, conduit entry devices or blanking devices shall not compromise the degree of ingress protection level IP6X for use in the presence of combustible dusts.

The unit has an ingress protection of IP66/67 and therefore any conduit device fitted must maintain this.

#### WARNING

*Electrostatic hazard, clean only with damp cloth.*

#### 3.5.3.2 Mounting instructions

- 1) Attach the mounting bracket and adaptor (if required) to the AccuTrak housing and shaft with the fasteners provided with the mounting kit.
- 2) To ensure that the AccuTrak is mounted correctly, it may be necessary to stroke the actuator to the fully closed position.

#### WARNING

*Before stroking the actuator to the fully closed position, please ensure that the process is safe to do so.*

- 3) With the actuator in the correct position, attach the Accutrak / bracket to the actuator using the hardware provided in the mounting kit.
- 4) To release the cover, loosen the cover retaining screws. Twist the cover approx 45° and lift up. See figure 20 below.
- 5) To set the switches, lift the bottom cam and turn until the switch has activated and then release. The spring will push the cam back onto the splined shaft.

#### WARNING

*Before stroking the actuator, please ensure that the process is safe to do so and that all hands are kept away from the moving shaft.*

- 6) Stroke the actuator to the opposite end of travel. Set the top cam by pushing down and turning the cam until the switch is activated.

#### WARNING

*Before stroking the actuator, please ensure that the process is safe to do so and that all hands are kept away from the moving shaft.*

- 7) Stroke the actuator from one end of stroke to the other several times to check the switch operation. If the switches require adjustment, repeat steps 5) to 7).

# GIL DOUBLE ACTING DIRECT GAS LINEAR ACTUATOR

## INSTALLATION, OPERATION AND MAINTENANCE MANUAL

### 3.5.3.3 Field wiring and installation

#### WARNING

The 3000 series should always be handled with care when the cover is removed.

**NOTE:** Before electrical installation, please read and follow the wiring diagram located inside the cover. The electrical ratings can be found on the product I.D label.

- 1) Field wiring must be carried out in accordance with site, local and national electrical codes / requirements. This includes special attention to earth bond to the aluminium or stainless steel enclosure using the internal and external earth points provided.
- 2) Installation of this product shall be carried out by competent personnel in accordance with the applicable code of practice such as EN 60079-14.

- 3) The certification applies to equipment WITHOUT cable glands. When mounting the enclosure in the hazardous area, only suitably rated IP66/67 or 68 ATEX certified glands MUST BE USED.
- 4) All unused cable entries MUST be plugged with a suitably rated IP66/67 or 68 ATEX certified blanking devices.
- 5) The first two digits of the Westlock nomenclature signifies the series with the third digit defining whether the product has a visual beacon or not. The fourth digit identifies the switch / sensor type. The fifth digit details the enclosure material; R = Resin, A = Aluminium, S = Stainless steel  
The table below details the applicable ambient ranges.

FIGURE 20

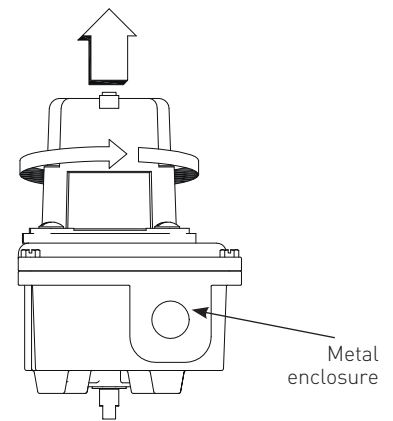
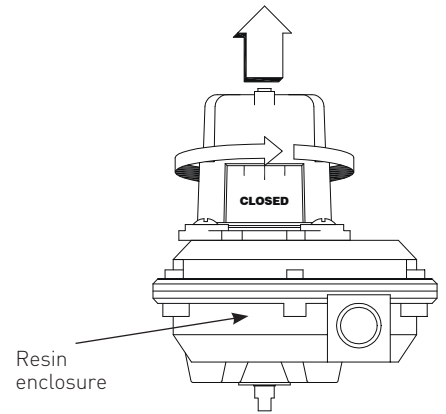

Equipment	Tamb (Ta) range	
Inductive proximity sensor (IFM) type: NS5002 (PTB 01ATEX2191) (IECEX BVS 06.0003)	ATEX	(T6) -20°C to +55°C
	(1G)	(T5) -20°C to +60°C
	IEC	-20°C to +60°C
Inductive proximity sensor (Turck): sensors type group A (KEMA 02 ATEX 1090X) (IECEX KEM 06.0036X)	-40°C to +*°C (* See certificate ≤ +60°C)	
	-25°C to +60°C	
Cylindrical inductive sensors (P+F) types NC and NJ (PTB 00ATEX2048X)	-40°C to +*°C (* See certificate ≤ +60°C)	
Cuboidal inductive sensors (P+F) types NJ and NC (PTB 00ATEX2032X)	-40°C to +*°C (* See certificate ≤ +60°C)	
SN-sensors (Pepperl + Fuchs) types NJ (PTB 00ATEX2049X)	(T1 - T6)	-40°C to +60°C
Magnum XT90 proximity switch	(T1 - T6)	-40°C to +60°C
V3 microswitches	(T1 - T6)	-40°C to +60°C
CS transmitter	(T1 - T4)	-40°C to +60°C
RS transmitter (Bourns type 3852C)	(T1 - T4)	-40°C to +60°C

FIGURE 21

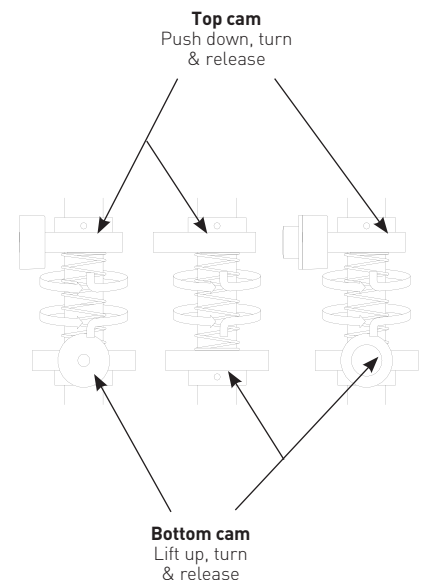

# GIL DOUBLE ACTING DIRECT GAS LINEAR ACTUATOR

## INSTALLATION, OPERATION AND MAINTENANCE MANUAL

### NOTES

- The working ambient temperature of the enclosures shall be as follows:  
Resin enclosure: -20 to +40°C  
Aluminium or stainless steel enclosure: -40 to +60°C
- The maximum upper ambient temperature of the equipment when installed with P&F sensors is dependent on its certificate parameters with regards to 'T' class and barrier type.
- If the CS or RS transmitter is used in conjunction with any switches, sensors or solenoids then the max surface temp for gas and dust shall be shown on the label.
- The electrical rating of the internal components are as follows:

The maximum upper ambient temperature shall not be considered to be higher than the following limits:  
Resin enclosure = +40°C  
Aluminium or stainless steel enclosure = +60°C

Switch type	Electrical rating	Cat. no.
V3 mechanical SPDT gold plated – simple apparatus	Ui = 30 V, li = 100 mA, Pi = 1 W, Ci = 10 nF, Li = 10 µH	1
Magnum XT90 proximity switch – simple apparatus	Ui = 30 V, li = 100 mA, Pi = 1 W, Ci = 10 nF, Li = 10 µH	1
CS transmitter	Ui = 28 V, li = 100 mA, Pi = 0.75 W, Ci = 68.3 nF, Li = 0 µH	1
RS transmitter (Bourns type 3852C)	Ui = 28 V, li = 100 mA, Pi = 0.75 W	1
IFM NS5002 (BVS 04 ATEX E153) Ex ia IIB only*	Ui = 15 V, li = 50 mA, Pi = 120 mW, Ci = 80 nF, Li = 110 µH	1
Turck sensors (KEMA 02 ATEX 1090X – type group 'A')	Ui = 20 V, li = 60 mA, Pi = 200 mW, Ci = 150 nF, Li = 150 µH	1

P&F sensor number	Certificate number	Cat. no.	P&F sensor number	Certificate number	Cat. no.
NJ2-V3-N...	PTB 00ATEX2032X (SUPP 2)	1	NJ2-12GM-N...	PTB 00ATEX2048X (SUPP 1)	1
NCB2-V3-N0...	PTB 00ATEX2032X (SUPP 2)	1	NJ4-12GM-N...	PTB 00ATEX2048X (SUPP 1)	1
			NJ5-18GM-N...	PTB 00ATEX2048X (SUPP 1)	1
NCB1,5-...M...-N0...	PTB 00ATEX2048X (SUPP 1)	1	NJ8-18GM-N...	PTB 00ATEX2048X (SUPP 1)	1
NCB2-12GM...-N0...	PTB 00ATEX2048X (SUPP 1)	1			
NCN4-12GM...-N0...	PTB 00ATEX2048X (SUPP 1)	1	NJ2-11-SN-G...	PTB 00ATEX2049X (SUPP 1)	1
NCB5-18GM...-N0...	PTB 00ATEX2048X (SUPP 1)	1	NJ2-11-SN...	PTB 00ATEX2049X (SUPP 1)	1
NCN8-18GM...-N0...	PTB 00ATEX2048X (SUPP 1)	1	NJ2-12GK-SN...	PTB 00ATEX2049X (SUPP 1)	1
NCB10-30GM...-N0...	PTB 00ATEX2048X (SUPP 1)	1	NJ3-18GK-S1N...	PTB 00ATEX2049X (SUPP 1)	1
NCN15-30GM...-N0...	PTB 00ATEX2048X (SUPP 1)	1	NJ4-12GK-SN...	PTB 00ATEX2049X (SUPP 1)	1
NJ2-11-N...	PTB 00ATEX2048X (SUPP 1)	1	NJ5-18GK-SN...	PTB 00ATEX2049X (SUPP 1)	1
NJ2-11-N-G...	PTB 00ATEX2048X (SUPP 1)	1	NJ5-30GK-S1N...	PTB 00ATEX2049X (SUPP 1)	1
			NJ8-18GK-SN...	PTB 00ATEX2049X (SUPP 1)	1

- Before replacing the enclosure cover, ensure that both of the housing and cover sealing surfaces are clean and undamaged. Tighten the cover screws hand tight using a suitably sized screwdriver or a metric 8mm A/F spanner / socket.

### 3.5.3.4 Product repair and service

- Inspection of this product shall be carried out by suitably trained personnel in accordance with the applicable code of practice such as EN 60079-17.
- In the event of any repairs that may be required such tasks must be carried out by suitably trained / competent personnel in accordance with the applicable code of practice such as EN 60079-19.
- The certification of this product has been approved based on the material of construction as per the drawings listed in the schedule within this certificate. Any replacement parts that are not made in accordance to the listed drawing will invalidate the approval / certification.
- Replacement parts must be purchased through Westlock Controls UK Ltd or via an approved Westlock Controls distributor.

# GIL DOUBLE ACTING DIRECT GAS LINEAR ACTUATOR

## INSTALLATION, OPERATION AND MAINTENANCE MANUAL

FIGURE 22  
Flow regulator placed on manual hand pump

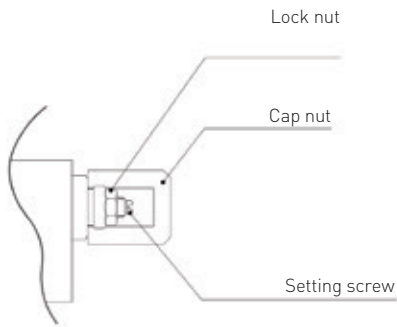

### 3.6 Calibration of the operating time

For GIL actuator, the operating time is adjustable through two regulation valves placed on manual hand pump body (see section 7.2 figure 27 :sectional drawing for hydraulic control unit MHP ).

To carry out the adjustment, use a suitable Allen wrench and follow these steps (figure 22):

- Remove the cap nut.
- Loosen the locknut.
- Screw with a screwdriver the setting screw to increase the operating time.
- Unscrew with a screwdriver the setting screw to decrease the operating time.
- After the adjustment is over screw the locknut and put back in place the cap nut.

## 4 OPERATIONAL TESTS AND INSPECTIONS

### IMPORTANT

To ensure the guaranteed SIL Level, according to IEC 61508, the functionality of the actuator must be checked at regular intervals, as described in the Safety Manual.

## 5 MAINTENANCE

### IMPORTANT

Before carrying out any maintenance operation, it is necessary to close the pneumatic supply line and exhaust the pressure from the actuator cylinder and the control unit (if foreseen), to ensure safety of maintenance staff.

### WARNING

Installation, commissioning, maintenance and repair works should be carried out by qualified staff.

### 5.1 Periodic maintenance

GIL actuators are designed to operate long-term in heavy-duty operating conditions, without maintenance.

### IMPORTANT

Periodicity and regularity of inspections is influenced particularly by specific environmental and working conditions.

Initially, they can be determined experimentally and then improved according to actual maintenance conditions and needs.

Notwithstanding, the following is recommended every 2 years of operation:

- Check that the actuator operates the valve correctly and with the required operating times. If the actuator operation is very infrequent, carry out a few opening and closing operations with all the existing controls (remote control, local control, emergency controls, etc.), if this is allowed by the conditions of the plant.
- Check there are no hydraulic or pneumatic leakages. If necessary, tighten the nuts of the pipe-fittings.
- Check oil level (figure 23) into the hydraulic manual hand pump, if present (section 5.1.1)
- Check that the actuators have not suffered accidental damage with oil leakages found on site (section 4.1.1).
- Check that improper closing of the control-group cover did not produce condensation on it.
- Check the integrity of worn out parts (gaskets, pads etc.).
- Replace, if any, the mechanical filter of the supply gas (refer to section 5.1.2)

FIGURE 23  
Level measuring stick



# GIL DOUBLE ACTING DIRECT GAS LINEAR ACTUATOR

## INSTALLATION, OPERATION AND MAINTENANCE MANUAL

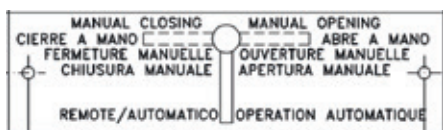

### 5.1.1 Check and restore oil level in the hydraulic manual hand pump

(refer to section 7.2 figure 27)

- Operate the distributor lever to "closing manual operation".
- Move the actuator into his "fail to close" position.
- Unscrew the dipstick (1).
- Check that the oil level into the tank (4) is in correspondence of the "MAX LEVEL" notch of the dipstick.
- Screw and tighten the dipstick.
- If necessary substitute or add the oil, proceeding as follows:
  - Remove the dipstick (1) from the tank cover (22).
  - Unscrew the plug (27) and the washer (9) to drain all the oil.
  - If some dirt or/and sludge is found in the oil drained from the tank, before filling with new oil in the tank, disassemble the oil tank tube, by unscrewing the two cap nuts (2), and clean the internal surfaces of the tank. If necessary substitute the gaskets (21) of the tank.
  - Replace the plug (27) and the washer (9) into the plate (11) and tighten.
  - Pour the new oil into the tank through the dipstick hole (1) on the cover (22).
  - Replace the dipstick (1).
  - Add oil (refer to table 2) if in the tank the oil level is BELOW THE MINIMUM (figure 23: minimum level is in correspondence to the end of dipstick) until to reach the optimal (MAXIMUM) oil level.
  - Operate the distributor lever to "Remote" position.

### IMPORTANT

For refill use oil of the same brand as previous, refer to related technical documentation

**TABLE 2**

### Features of hydraulic oil suggested for refilling in different working conditions

Standard temperature conditions (-30°C/+85°C)	
Producer	AGIP
Name	ARNICA 22
Viscosity at 40°C	20.9 mm <sup>2</sup> /s
Viscosity at 100°C	4.73 mm <sup>2</sup> /s
Viscosity index ASTM	153
Flash point	192°C
Pour point	-42°C
Specific weight (at 15°C)	0,857 kg/l
Equivalent oils	SHELL TELLUS PLUS 22 CHEVRON HYDRAULIC OIL AW ISO 22 MOBIL DTE22 EXXON UNIVIS N22 EQUIVIS ZS22 BP ENERGOL HLP-HM22 CASTROL DYSPIIN AWS22
Low temperature conditions (down to -46°C)	
Manufacturer	SHELL
Name	AEROSHELL FLUID 41
Viscosity at -54°C	2300 cST
Viscosity at -40°C	491 cST
Viscosity at 40°C	14.1 cST
Viscosity at 100°C	5.3 cST
Viscosity index (ISO 2909)	>200
Flash point	105°C
Pour point	< -60°C
Specific weight (Or equivalent)	0.87 kg/dm <sup>3</sup>
Low temperature conditions (down to -60°C)	
Manufacturer	SYNTHESIS
Name	SYNTRASS-CS 500
Viscosity at -60°C	580 cST
Viscosity at -30°C	39cST
Viscosity at 20°C	5.8 cST
Viscosity at 50°C	2.1 cST
Flash point	152°C
Pour point	-68°C
Specific weight (Or equivalent)	0.897 kg/dm <sup>3</sup>

# GIL DOUBLE ACTING DIRECT GAS LINEAR ACTUATOR

## INSTALLATION, OPERATION AND MAINTENANCE MANUAL

FIGURE 24

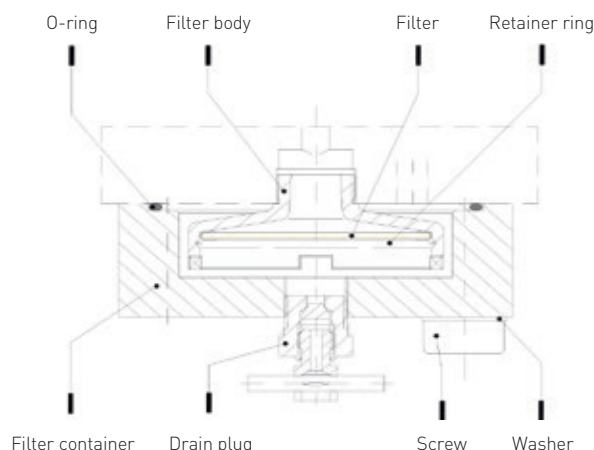

### 5.1.2 Gas supply dehydrating filter maintenance (if foreseen)

The gas supply filter is fitted with a mechanical filter and a drain valve to discharge periodically the water generated by the condensation of the humidity inside the gas supply.

During the routine maintenance it is recommended to check and clean the mechanical filter and replace it in case of heavy dirty conditions.

To disassemble the filter proceed as follows:

- close the stop valve at the inlet of pressure supply line;
- discharge the pressure from the drain valve;
- Remove the lower enclosure screws,
- remove the mechanical filter;
- clean or replace the filter;

Reinstall all parts carefully paying attention to avoid any damage to the O-ring.

### 5.1.3 Lubrication of actuator

For normal duty the GIL actuator is lubricated "for life". In case of high load and high and high frequency of operation it may be necessary to periodically restore the lubrication: it is advisable to apply a generous coating of grease on the contact surfaces of moving parts.

The following grease is used by Biffi for standard working temperature and suggested for relubrication (see table).

AGIP MU/EP/2	AEROSHELL GREASE 7 or equivalent
To be used in standard temperature conditions (-30°C/+85°C)	To be used in low temperature conditions (-60°C/+65°C)
NLGI consistency: 2	Color: Buff
Worked penetration: 280 dmm	Physical state: Semi-solid at ambient temperature
ASTM dropping point: 185°C	Odor: Slight
Base oil viscosity at 40°C: 160 mm <sup>2</sup> /s	Density: 966 kg/m <sup>3</sup> at 15°C
ISO classification: L-X-BCHB 2	Flash point: >215°C (COC)(based on synthetic oil)
DIN 51 825: KP2K - 20	Dropping point: 260°C (ASTM D-566)
Equivalent to:	Product code: 001A0065
ESSO BEACON EP2	Infosafe no.: ACISO GB/eng/C
BP GREASE LTX2	
SHELL ALVANIA GREASE R2	
ARAL ARALUB HL2	
CHEVRON DURALITH GREASE EP2	
CHEVRON SPHEEROL AP2	
TEXACO MULTIFAK EP2	
MOBILPLEX 47	
PETROMIN GREASE EP2	

# GIL DOUBLE ACTING DIRECT GAS LINEAR ACTUATOR

## INSTALLATION, OPERATION AND MAINTENANCE MANUAL

### 5.2 Extraordinary maintenance

If there are leakages to double cylinder, or a malfunction in the mechanical components, or in case of scheduled preventive maintenance, the actuator must be disassembled and seals must be replaced with reference to the follow general sectional drawing and adopting the following procedures:

#### 5.2.1 Replacement of cylinder seals (refer to figure 26)

#### IMPORTANT

Before executing any maintenance operation, it is necessary to intercept the supply line and discharge pressure from the cylinder of the actuator.

- 1) Unscrew the plug (18) from the adjusting screw cover (17).
- 2) Remove the adjusting screw cover (17) together with O-ring (20).
- 3) Measure the distance of the protrusion of adjusting screw (14) with reference to the end flange (22) surface, so as to be able to easily restore the setting of the actuator mechanical stop, once the maintenance procedures have been completed.
- 4) Loosen the stop screw (14) until it is removed from the end flange (13)
- 5) Unscrew the nuts (15) from the tie rods (16) from the side of the end flange: they must be gradually unscrewed all at the same time.
- 6) Slide off the end flange (13) and the tube (10).

FIGURE 25

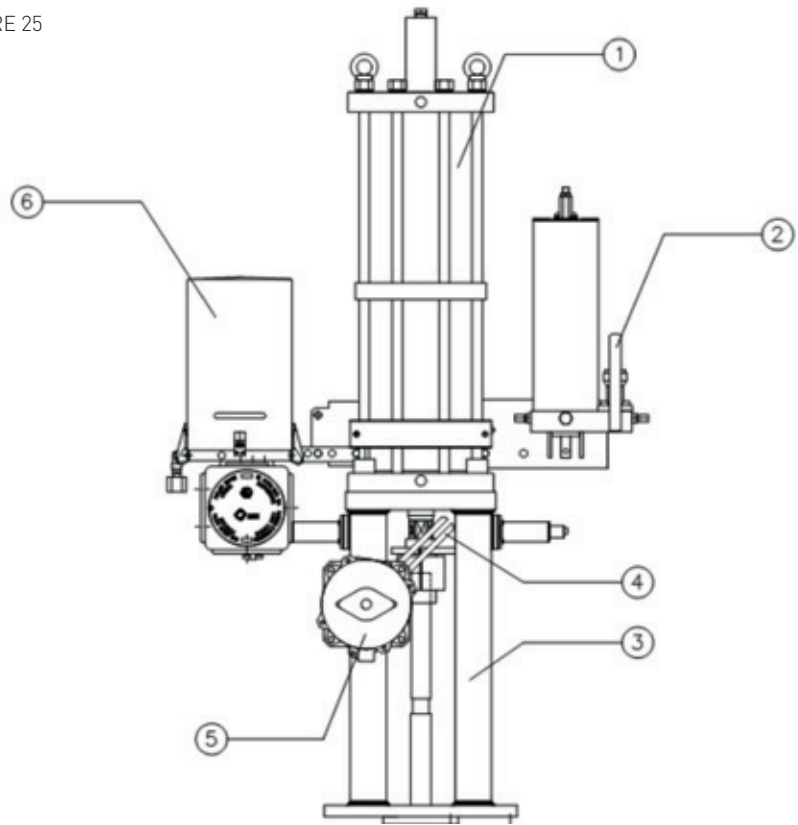

#### PARTS LIST

Item	Qty	Description	Reference figure for maintenance operations
1	1	Cylinder gas-hydraulic	Figure 26
2	1	Emergency manual hand pump	Figure 27, 28
3	1	Pedestal with coupling joint and mechanical latch	Figure 29, 30
4	1	Mounting kit for limit switch box	Figure 31
5	1	Limit switch box	Refer to model-catalog
6	1	Pneumatic control group	Figure 32

# GIL DOUBLE ACTING DIRECT GAS LINEAR ACTUATOR

## INSTALLATION, OPERATION AND MAINTENANCE MANUAL

---

### Seals replacement

Prior to reassembly check that the actuator components are in good condition and clean. Lubricate all the surfaces of the parts which move in contact with other components, with a recommended oil. If the O-ring must be replaced, remove the existing one from its groove, clean the groove carefully and lubricate it with a protective oil. Assemble the new O-ring into its groove and lubricate it with a protective oil.

- 1) Replace the O-ring (5) of the head flange (1).
- 2) Replace the O-ring (5) and the guide sliding ring (8) of the piston(7).  
Replace the O-ring (5) of the end flange (13).
- 3) Remove the O-ring (20) from the stop screw cover (17). Carefully clean and lubricate the stop screw thread and the surface of the end flange area, on which the sealing works.
- 4) Screw the new sealing onto the stop screw.

### Reassemble

- 1) Carefully clean the inside of the tube (10) and check that the entire surface, particularly that of the bevels, is not damaged. Lubricate the inside surface of the tube and the bevels at the ends. Slide the tube onto the piston taking care not to damage the piston O-ring (5) and the head flange O-ring (5).
- 2) Assemble the end flange by centring it on the inside diameter of the tube, taking care not to damage the O-ring (3) and the seal ring (4).
- 3) Assemble the the nuts (15) onto the tie rods (16). Tighten the nuts to the recommended torque, alternating between opposite corners.
- 4) Screw the stop screw (14) into the threaded hole of the end flange until it reaches its original position (the same protrusion with reference to the flange surface). To make the operation easier feed the pneumatic cylinder with air (if possible) in order to move the piston.
- 5) Tighten the adj. screw cover (17) and the plug (18).

### IMPORTANT

Carry out a few operations (section 3.3) to check there are no leakages from the gaskets.



### 5.3 Dismantling and demolition

#### WARNING

*Before disassembling the actuator it is necessary to close the pneumatic feed line and discharge pressure from the cylinder of the actuator, from the control unit and from the accumulator tank, if present.*

*The demolition of the actuator both concerning any electrical and mechanical parts should be made by specialized staff.*

Before starting the disassembly a large area should be created around the actuator so to allow any kind of movement without problems of further risks created by work-site.

Separate the parts composing the actuator according to their nature (ex. metallic, and plastic materials, fluids etc.) and send them to differentiated waste collection sites, as provided for by the laws and provisions in force.

# GIL DOUBLE ACTING DIRECT GAS LINEAR ACTUATOR

## INSTALLATION, OPERATION AND MAINTENANCE MANUAL

---

### 6 TROUBLESHOOTING

---

#### 6.1 Failure or breakdown analysis

Event	Possible cause	Remedy
Actuator does not work	<ol style="list-style-type: none"><li>1. Lack of power supply</li><li>2. Lack of pneumatic supply</li><li>3. Blocked valve</li><li>4. Wrong position of the distributor of the manual hydraulic group</li><li>5. Failure of the control group</li><li>6. Low supply pressure</li></ol>	<ol style="list-style-type: none"><li>1. Restore it</li><li>2. Open line interception valve</li><li>3. Repair or replace</li><li>4. Restore correct position</li><li>5. Call Biffi Customer Service</li><li>6. Restore (section 1.4)</li></ol>
Actuator too slow	<ol style="list-style-type: none"><li>1. Low supply pressure</li><li>2. Wrong calibration of flow regulator valves</li><li>3. Wear of the valve</li></ol>	<ol style="list-style-type: none"><li>1. Restore (section 1.4)</li><li>2. Restore (section 3.6)</li><li>3. Replace</li></ol>
Actuator too fast	<ol style="list-style-type: none"><li>1. High supply pressure</li><li>2. Wrong calibration of flow regulator valves</li></ol>	<ol style="list-style-type: none"><li>1. Restore (section 1.4)</li><li>2. Restore (section 3.6)</li></ol>
Leakages on hydraulic or pneumatic circuits	<ol style="list-style-type: none"><li>1. Deterioration and/or damage to gaskets</li></ol>	<ol style="list-style-type: none"><li>1. Call Biffi Customer Service</li></ol>
Incorrect position of the valve	<ol style="list-style-type: none"><li>1. Wrong adjustment of mechanical stops</li><li>2. Wrong warning of microswitches</li></ol>	<ol style="list-style-type: none"><li>1. Restore (section 3.4)</li><li>2. Restore (section 3.5)</li></ol>
Hydraulic manual pump does not work	<ol style="list-style-type: none"><li>1. Handle positioned on remote control</li><li>2. Leakages on the check valve of the hydraulic control group</li></ol>	<ol style="list-style-type: none"><li>1. Re-position the operation indication handle to manual</li><li>2. Call Biffi Customer Service</li></ol>

### 7 LAYOUTS

---

#### 7.1 Spare parts order

For spare parts order to the relevant Biffi office please make reference to Biffi order confirmation concerning all the supply, and serial number of the actuator (section 1.2) for any specific spare part for a specific actuator model.

Please send every spare-parts request to:  
Biffi Italia S.r.l.  
Servizio Assistenza Tecnica Clienti  
E-mail: [spareservice@biffi.it](mailto:spareservice@biffi.it)

Please specify:

1. Actuator model
2. Biffi acknowledgement
3. Spare parts code
4. Quantity
5. Transport condition
6. Involved people

# GIL DOUBLE ACTING DIRECT GAS LINEAR ACTUATOR

## INSTALLATION, OPERATION AND MAINTENANCE MANUAL

### 7.2 Parts list for maintenance and replacing procedure

FIGURE 26  
Single acting-spring return hydraulic linear actuator

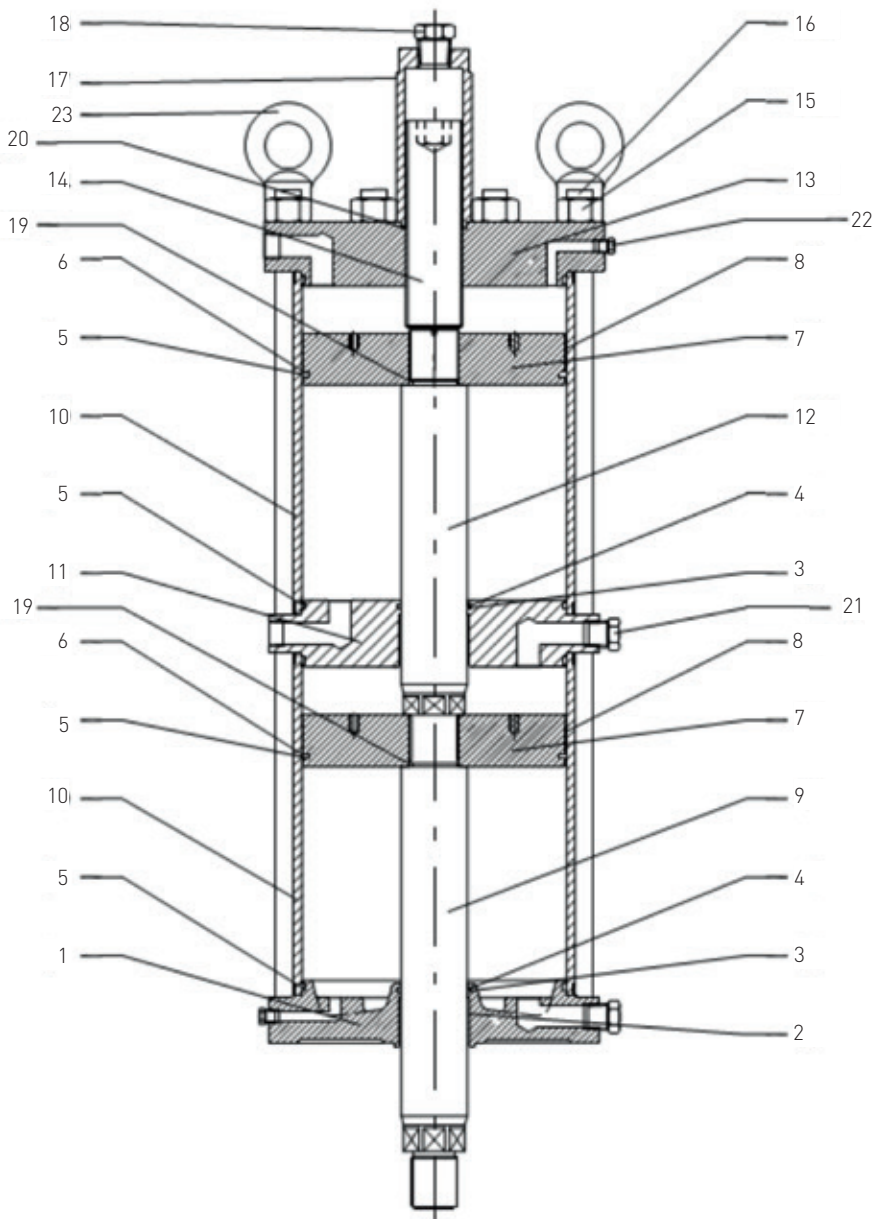

#### PARTS LIST

Item	Qty	Description	Material	Item	Qty	Description	Material
1	1	Head flange	Carbon steel	13	1	End flange	Carbon steel
2	2	Piston rod bushing	Steel + bronze + PTFE	14	1	Stop setting screw protection	Stainless steel AISI 316
3	2	O-ring	NBR	15	8	Nut	Stainless steel AISI 316LMO
4	2	Piston rod seal ring	PTFE + graphite	16	8	Tie rod	SS ASTM A 564-630
5	4	O-ring	NBR	17	1	Stop setting screw protection	Carbon steel
6	2	Piston seal ring	PTFE + graphite	18	1	Plug	Carbon steel
7	2	Piston	Carbon steel	19	2	O-ring	NBR
8	4	Guide sliding ring for piston	PTFE + graphite	20	1	O-ring	NBR
9	1	Piston rod	SS ASTM A 564-630 chrom. plated	21	1	Plug	Carbon steel
10	2	Cylinder tube	Carbon steel	22	6	Plug	Carbon steel
11	1	Intermediate flange	Carbon steel	23	2	Eyebolt	Carbon steel
12	1	Differential rod	SS ASTM A 564-630 chrom. plated				

# GIL DOUBLE ACTING DIRECT GAS LINEAR ACTUATOR

## INSTALLATION, OPERATION AND MAINTENANCE MANUAL

FIGURE 27  
Hydraulic control unit MHP - Emergency manual hand pump

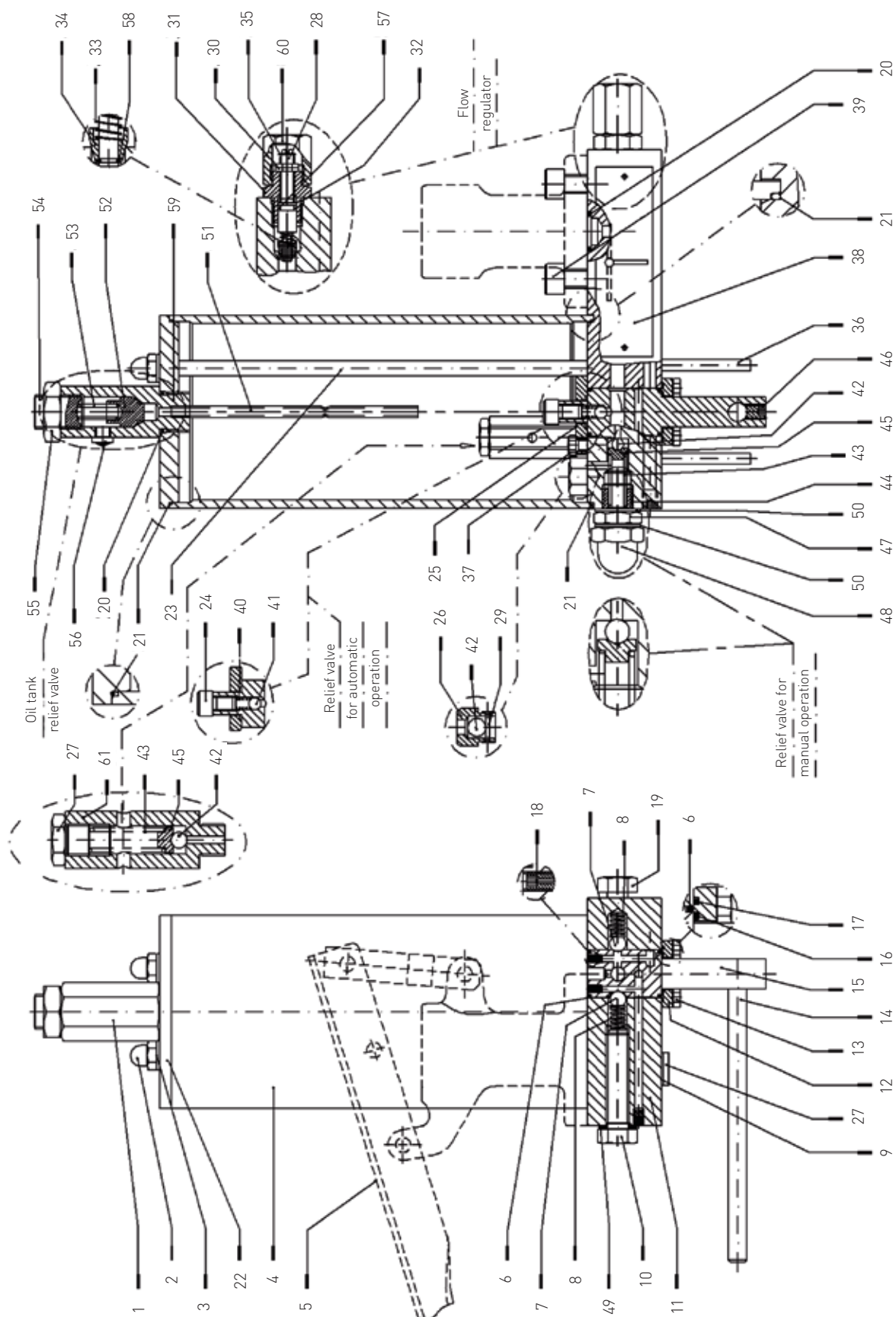

# GIL DOUBLE ACTING DIRECT GAS LINEAR ACTUATOR

## INSTALLATION, OPERATION AND MAINTENANCE MANUAL

### PARTS LIST - HYDRAULIC CONTROL UNIT MHP

Item	Q.ty	Description	Material
1	1	Dipstick	---
2	2	Cap nut	Carbon steel
3	2	Washer	Carbon steel + rubber
4	1	Hydraulic tank	Carbon steel
5	1	Hand pump	See attached table
6*	2	O-ring	Fluorosilicon rubber
7	2	Ball	Stainless steel
8	2	Spring	Spring steel
9	1	Washer	Carbon steel + rubber
10	1	Screw	Carbon steel
11	1	Plate	Carbon steel
12	1	Flange	Aluminium
13	4	Screw	Carbon steel
14	1	Lever	Carbon steel
15	1	Distributor	Stainless steel
16*	1	O-ring	Fluorosilicon rubber
17*	1	O-ring	Fluorosilicon rubber
18	1	Nozzle	Carbon steel
19	2	Screw	Carbon steel
20*	3	O-ring	Fluorosilicon rubber
21*	2	O-ring	Fluorosilicon rubber
22	1	Tank cover	Carbon steel
23	2	Tie rod	Carbon steel
24	1	Screw	Carbon steel
25	1	Flange	Aluminium
26	2	Check valve body	Aluminium
27	2	Plug	Carbon steel
28	2	Flow control valve setting screw	Stainless steel
29	2	Spring pin	Stainless steel
30	2	Nut	Carbon steel
31	2	Flange	Carbon steel
32*	2	O-ring	Fluorosilicon rubber
33	2	Spring	Spring steel
34	2	Plug	Stainless steel
35	2	Retainer ring	Spring steel
36	2	Spring pin	Carbon steel
37	4	Screw	Carbon steel
38	1	Operation instruction plate	Stainless steel
39	4	Screw	Carbon steel
40	1	Spring	Stainless steel
41	1	Ball	Stainless steel
42	4	Ball	Stainless steel
43	2	Spring	Spring steel
44	1	Relief valve setting screw	Stainless steel
45	2	Spring pin	Carbon steel
46	1	Screw	Alloy steel
47	1	Spring	Stainless steel
48	1	Nut	Carbon steel
49	1	Washer	Carbon steel + rubber
50	2	Washer	Carbon steel + rubber
51	1	Dipstick	Stainless steel
52*	1	Plug + O-ring	
53	1	Spring	Stainless steel
54	1	Screw	Alloy steel
55	1	Nut	Carbon steel
56	1	Silencer	Brass
57*	2	O-ring	Fluorosilicon rubber
58	2	Retainer ring	Spring steel
59	1	Dipstick body	Aluminium
60	2	Nut	Carbon steel
61	1	Relief valve body	Aluminium

\* Recommended spare parts

# GIL DOUBLE ACTING DIRECT GAS LINEAR ACTUATOR

## INSTALLATION, OPERATION AND MAINTENANCE MANUAL

FIGURE 28  
Manual hand pump (MHP)

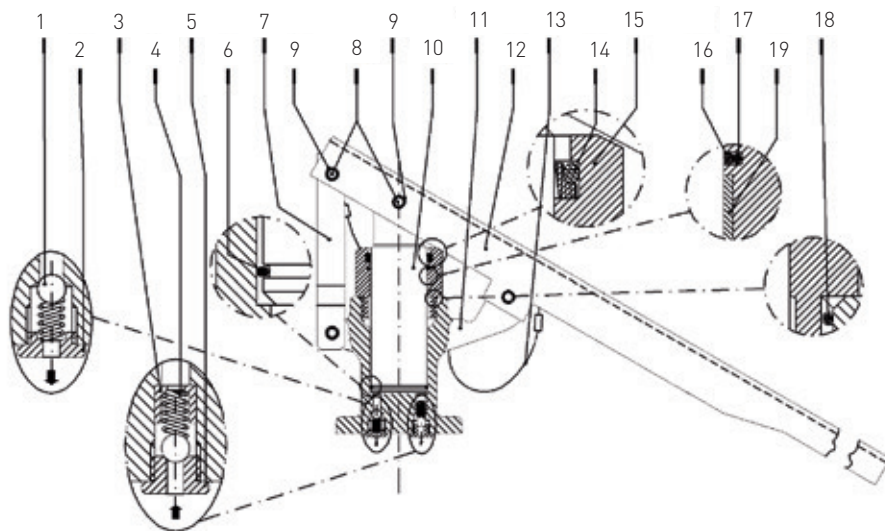

Item	Q.ty	Description	Material
1	2	Ball	Stainless steel
2	1	Delivery valve bush	Carbon steel
3	1	Suction valve bush	Carbon steel
4	2	Spring	Stainless steel
5	1	Suction valve ring	Carbon steel
6	1	Spring retainer ring	Carbon steel
7	1	Fork	Carbon steel
8	2	Pin	Stainless steel
9	4	Retainer ring	Carbon steel
10	1	Rod	Chromium plated alloy steel
11	1	Body	Carbon steel
12	1	Lever	Carbon steel
13	1	Split pin with rope	Nylon + carbon steel
14*	1	Scraper ring	PTFE + fluorosilicon rubber
15	1	Threaded bush	Aluminium
16*	2	Rod seal ring	PTFE + graphite
17*	2	O-ring	NBR
18*	1	O-ring	NBR
19	1	Piston rod bushing	Steel + bronze + PTFE

\* Recommended spare parts

# GIL DOUBLE ACTING DIRECT GAS LINEAR ACTUATOR

## INSTALLATION, OPERATION AND MAINTENANCE MANUAL

FIGURE 29  
Pedestal with coupling joint

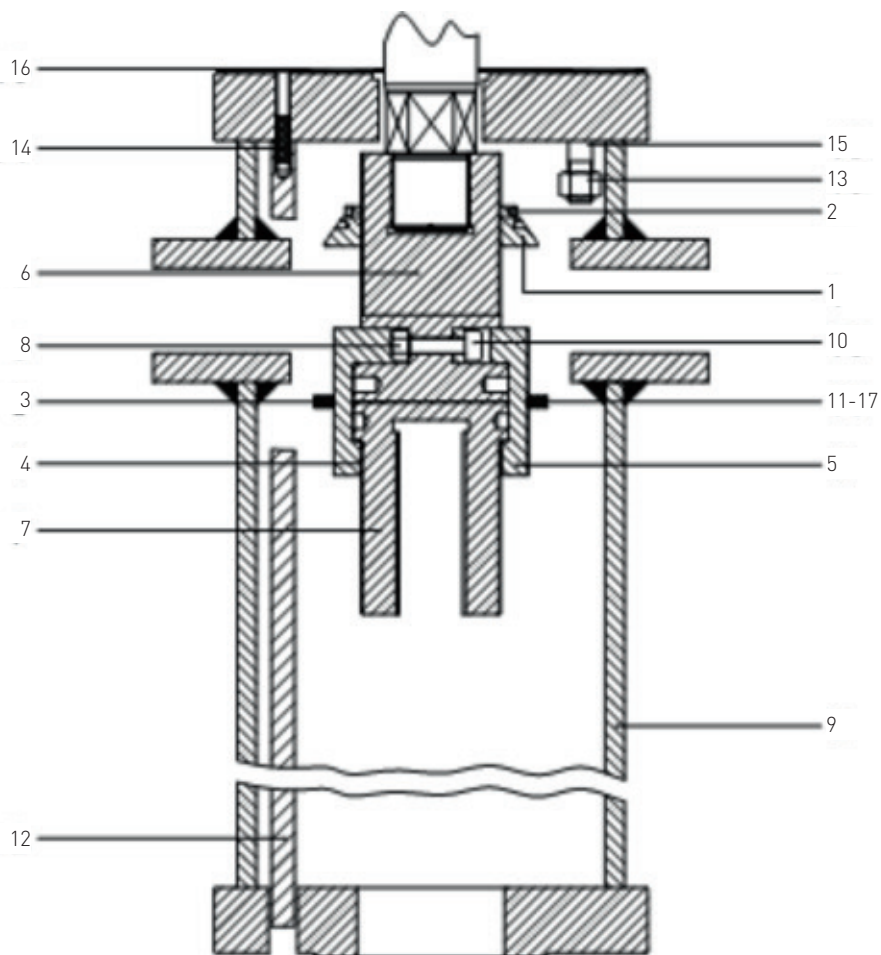

### PARTS LIST

Item	Qty	Description	Material
1	1	Travel stop disc	Stainless steel
2	1	Locking ring	Stainless steel
3	1	Position indicator ring	Stainless steel
4	2	Spacer	Stainless steel
5	1	Joint shell	Stainless steel
6	1	Actuator joint	Stainless steel
7	1	Stem valve joint	Stainless steel
8	4	Nut	Stainless steel
9	1	Pedestal	Carbon steel
10	4	Screw	Stainless steel
11	3	Dowel	Stainless steel
12	1	Anti rotation shaft	Stainless steel
13	8	Nut	Alloy steel
14	1	Dowel	Stainless steel
15	8	Stud bolt	Alloy steel
16	1	Gasket	Idroflex
17	2	Screw	Stainless steel

# GIL DOUBLE ACTING DIRECT GAS LINEAR ACTUATOR

## INSTALLATION, OPERATION AND MAINTENANCE MANUAL

FIGURE 30  
Pedestal with coupling joint - Mechanical latch

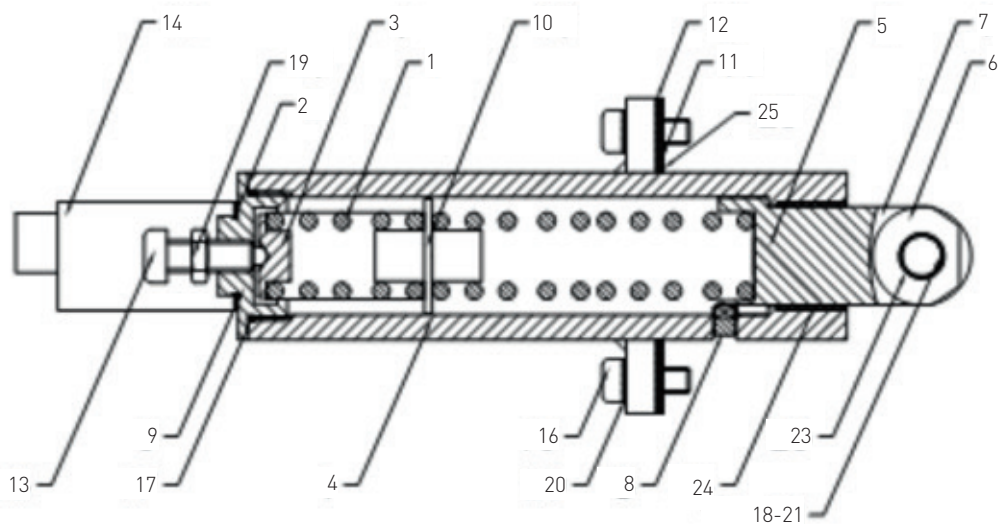

### PARTS LIST

Item	Qty	Description	Material
1	4	Spring	Spring steel
2	2	Washer	PTFE
3	2	Disc	Carbon steel
4	2	Mechanical latch body	Carbon steel
5	2	Bracket wheel	Stainless steel
6	2	Wheel	Stainless steel
7	2	Shaft	Stainless steel
8	2	Antirotation regulator	Stainless steel
9	2	End flange	Carbon steel
10	2	Spacer	Stainless steel
11	8	Thickness regulator	Stainless steel
12	8	Thickness regulator	Stainless steel
13	8	Stop setting screw	Stainless steel
14	2	Stop setting screw	Nylon
16	8	Screw	Stainless steel
17	2	O-ring	NBR
18	2	Nut	Stainless steel
19	2	Nut	Stainless steel
20	8	Washer	Stainless steel
21	2	Washer	Stainless steel
23	2	Bushing	Fiber + carbon steel
24	2	Bushing	Fiber + carbon steel
25	8	Thickness regulator	Stainless steel

# GIL DOUBLE ACTING DIRECT GAS LINEAR ACTUATOR

## INSTALLATION, OPERATION AND MAINTENANCE MANUAL

FIGURE 31  
Mounting kit for limit switch box

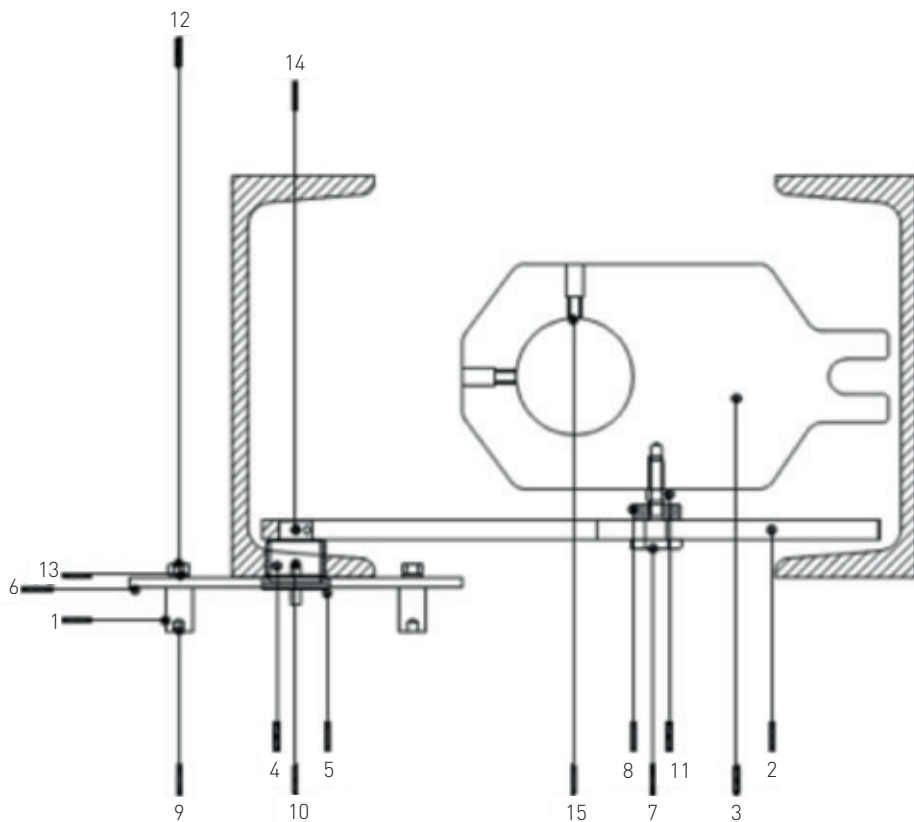

### PARTS LIST

Item	Qty	Description	Material
1	4	Screw	Stainless steel
2	1	Spacer	Stainless steel
3	1	Driving ring	Stainless steel
4	1	Bush	Bronze
5	1	Support stud	Stainless steel
6	1	Support plate	Stainless steel
7	1	Threaded screw	Stainless steel
8	1	Washer	Stainless steel
9	4	Screw	Stainless steel
10	2	Screw	Stainless steel
11	1	Nut	Stainless steel
12	4	Nut	Stainless steel
13	4	Washer	Stainless steel
14	2	Screw	Stainless steel
15	2	Screw	Stainless steel

# GIL DOUBLE ACTING DIRECT GAS LINEAR ACTUATOR

## INSTALLATION, OPERATION AND MAINTENANCE MANUAL

---

FIGURE 32  
Pneumatic control group

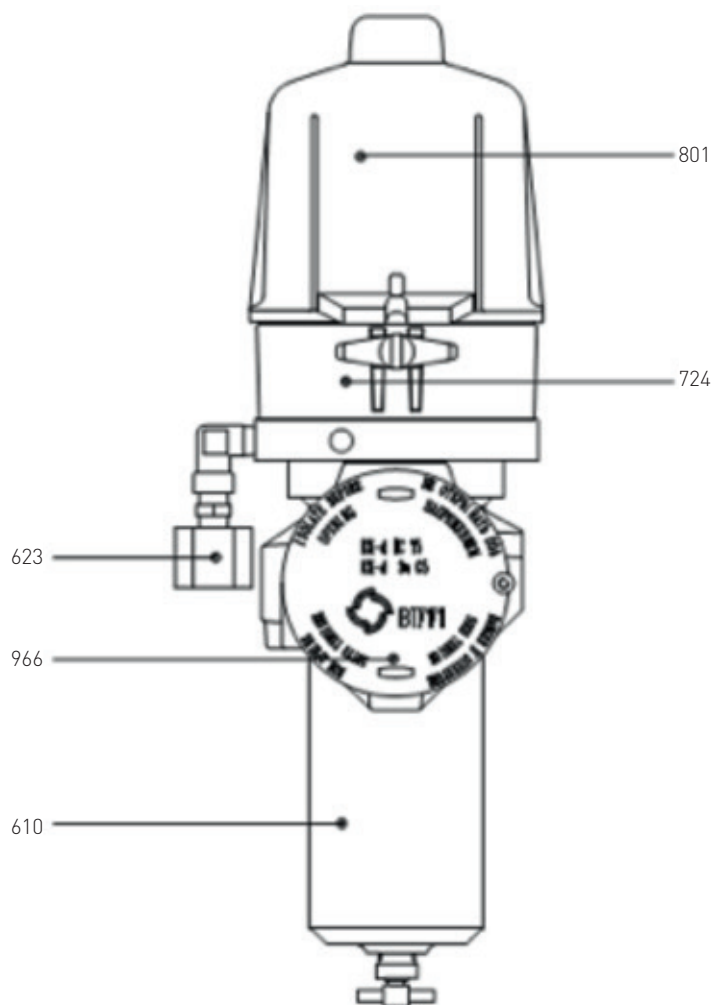

### PARTS LIST

Item	Qty	Description
610	1	Gas dehydrating filler/condensate separator
623	1	Dust excluder with check valve
724	1	Double 3/2 N.C. solenoid valve with manual override
801	1	Control valves enclosure with vent valve
966	1	Terminals enclosure

**8 DATE REPORT FOR MAINTENANCE OPERATIONS**

---

**Last maintenance operation date:**

(in factory, on delivery): .....

..... exec. by: .....

..... exec. by: .....

..... exec. by: .....

**Next maintenance operation date:**

..... exec. by: .....

..... exec. by: .....

..... exec. by: .....

**Start-up date:**

(in factory, on delivery): .....

(on plant): .....