

Biffi IMVS2000v2

Integrated Monitoring Valve System



Table of Contents

Section 1: Reference Documents

Section 2: General Safety Instructions

2.1	Manufacturer	2
2.2	Intended Use.....	2
2.3	Terms and Conditions	3
2.4	Manufacturer’s Liability.....	3
2.5	Applicable Standards and Regulations.....	4
2.6	CSA/CSAus Certifications Details.....	4

Section 3: Storage

Section 4: Device Description

4.1	General Description	8
4.1.1	Main Features.....	8
4.2	Identification of the Main Parts.....	9
4.3	Technical Specifications	12
4.4	Overall Dimensions	14
4.5	Options.....	14

Section 5: Working Principle and Detailed Description

5.1	Working Principle.....	15
5.1.1	Calibration	16
5.1.2	Signature	16
5.1.3	Opening and Closing FST (External Source).....	17
5.1.4	PST.....	17
5.1.5	SOVs Test	18
5.1.6	Closing FST Details	20
5.1.7	Opening FST Details	21
5.1.8	PST and SOV TEST Details.....	22
5.2	Detailed Description	31
5.2.1	Configuration-Managing Interfaces.....	31
5.2.2	Digital Input	31
5.2.3	Digital Output	34
5.2.4	SIS Signals - SOV Outputs	35
5.2.5	Position Sensor.....	35
5.2.6	Pressure Sensors	36
5.2.7	Alarms.....	36
5.2.8	Graphs – Sampling Time – Memory.....	37

Section 6: Configuration Parameters

6.1	Normal Mode Menu	58
6.2	“Act.Mode”and “SOVs Qty”	59

Section 7: Local Operator Interface

7.1	Normal Mode Menu	61
7.2	Log in Menu	62
7.3	View/Setup Mode Menu.....	63
7.3.1	View Graph of the Setup/View Mode Menus.....	63
7.3.2	Push-buttons Functionality	68

Section 8: Table of Alarms

Section 9: Wiring Diagrams – Signals Description

9.1	Signals Description.....	74
9.1.1	Standard Signals.....	74
9.1.2	Optional Card Signals	76
9.2	Wiring Diagrams	78
9.2.1	Configuration A – Wiring Diagram.....	78
9.2.2	Configuration B – Wiring Diagram	79
9.2.3	Configuration C – Wiring Diagram.....	80
9.2.4	Configuration D – Wiring Diagram	81
9.2.5	Configuration E – Wiring Diagram	82
9.2.6	Configuration F – Wiring Diagram	83
9.2.7	Configuration G – Wiring Diagram.....	84
9.2.8	Configuration H – Wiring Diagram	85
9.2.9	Hart Card – Wiring Diagram	86

Section 10: INSTALLATION – START-UP

10.1	Installation in ambient with explosive dusts.....	88
10.2	Checks to be performed before installation.....	88
10.3	Preliminary operations	89
10.4	Mechanical Connections	90
10.4.1	Mounting IMVS2000v2 onto RP/RPS type actuators	90
10.4.2	Mounting IMVS2000v2 onto ALGA/ALGAS type actuators	91
10.5	Pressure Connections.....	92
10.6	Cables and Electrical Connections.....	92
10.6.1	Cables Connection	92
10.6.2	Removing the electrical enclosure’s covers.....	94
10.6.3	Unused entries	96
10.6.4	Cables requirements – EMC protection.....	96
10.6.5	Wires dimensions	97
10.7	Commissioning Procedure	97

Section 11: Parts List

11.1	General Assembly	98
11.2	Spare Parts.....	100

Section 12: Decommissioning

Section 13: Trouble Shooting

Section 14: Ordering Table

Section 15: Document Revision

Section 1: Reference Documents

[1]: MDE231 IMVS2000v2 - Biffi-Assistant User Manual

[2]: MDE232 HRT_IMVS2000v2 User Manual

[3]: MDE243 IMVS2000v2 MODBUS User Manual

Section 2: General Safety Instructions

2.1 Manufacturer

The manufacturer with respect to Machinery Directive 2006/42/EC is Biffi Italia, as specified on the machinery label.

2.2 Intended Use

The IMVS2000v2 electro-mechanical device covered in this Instruction and Operating Manual is designed to provide the Partial Stroke Test, i.e., perform the valve/actuator test and/or movement able to verify and compare (diagnostic capability) signature values with ongoing test, in particular, the continuously position verification (via encoder) and pressure verification in actuator cylinder (these two functions are always active). IMVS2000v2 can be used in a wide range of applications (heavy industrial, chemical, petrochemical plants, waterworks, water pipelines, waste paper plants and power plants, etc). IMVS2000v2 devices are produced by Biffi Italia and identified by a label with a product designation code. Biffi Italia will not be liable for any possible damage or physical injury resulting from use in other than the designated applications or by lack of care during installation, operation, adjustment and maintenance of the machine. Such risks lie entirely with the user. Depending on the specific working conditions, additional precautions may be requested. Considering that Biffi Italia has no direct control over particular applications, operation or maintenance conditions, it is the operator's responsibility to comply with all applicable safety rules. Please inform Biffi Italia urgently if you face unsafe situations not described in this IOM. It is the sole responsibility of the operator to ensure that the local health and safety regulations are adhered to.

WARNING

It is assumed that the installation, setting, commissioning, maintenance and repair works are carried out by qualified personnel and checked by responsible Specialists.

WARNING

Any repair work other than the operations outlines in this IOM will be strictly reserved to qualified BIFFI ITALIA personnel or to personnel directly authorised by the Company itself.

WARNING

The flameproof joints are not intended to be repaired but where necessary the original manufacturer shall be contacted for guidance and information on the dimensions of the flameproof joints.

WARNING

The user shall be aware that all external fasteners on which the flameproof enclosure depends are stainless steel socket head cap screws class A4 -grade 70.

IMVS2000v2 devices are designed in accordance with the applicable International Rules and Specifications, but the following Regulations must be observed in any case:

- the general and safety regulations
- the plant specific regulations and requirements
- the proper use of personal and protective devices (glasses, clothing, gloves, etc)
- the proper use of tools, lifting and transport equipment

⚠ WARNING

The electronic parts of the IMVS2000v2 and all the options can be damaged by a discharge of static electricity. Before you start, touch a grounded metal surface to discharge any static electricity.

⚠ CAUTION

Danger of explosion if battery is incorrectly replaced.
Replace only with the same or equivalent type.

2.3 Terms and Conditions

Biffi Italia guarantees each single product to be free from defects and to conform to current goods specifications. The warranty period is one year from the date of installation by the first user, or eighteen months from the date of shipment to the first user, whichever occurs first. No warranty is given for products which have been subject to improper storage, improper installation, misuse, or corrosion, or which have been modified or repaired by unauthorised personnel. Repair work due to improper use will be charged at standard rates.

2.4 Manufacturer's Liability

Biffi Italia declines all liability in the event of:

- use of the device in contravention of local safety at work legislation
- incorrect installation, disregard or incorrect application of the instructions provided on the device nameplate and in this manual
- modifications without Biffi's authorisation
- work done on the unit by unqualified or unsuitable persons

2.5 Applicable Standards and Regulations

EN ISO 12100: Safety of machinery

EN 60204/1: Electrical equipment of industrial machines. Part 1- General requirements

2006/42/EC: Machinery directive

2004/108/EC: EMC Directive

2014/34/UE: ATEX Directive

97/23/EC: PED Directive

IEC 61508: Functional safety of E/E/PE safety-related systems (*)

CSA/CSAus certified (see paragraph 2.5.1 for details)

(*) The IEC 61508 standard is applied only to demonstrate that the IMVS2000v2 does not adversely affect the execution of the safety function (ESD) by the superior SIS and does not contribute to the PFDav.

2.6 CSA/CSAus Certifications Details

Canada

Class I Division 1 Groups B, C, D; T4

Class II, Groups E, F, and G; Class III

Ex db ia IIC T4 Gb

Ex tb IIIC T135 °C Db

Integrated Monitoring Valve System, Model IMVS2000v2,

Ambient temperature range -40 °C to +75 °C, Type 4, 4X, 6, IP66/68

Class I Division 1 Groups C, D; T4

Class II, Groups E, F, and G; Class III

Ex db ia IIB T4 Gb

Ex tb IIIC T135 °C Db

Integrated Monitoring Valve System, Model IMVS2000v2 with optional local indicator,

Ambient temperature range -40 °C to +75 °C, Type 4, 4X, 6, IP66/68

U.S.

Class I Division 1 Groups B, C, D; T4

Class II, Groups E, F, and G; Class III

Class I Zone1 AEx db ia IIC T4 Gb

Zone 21 AEx tb IIIC T135 Db

Integrated Monitoring Valve System, Model IMVS2000v2,

Ambient temperature range -40°C to +75°C, Type 4, 4X, 6, IP66/68

IMVS2000v2 Integrated Monitoring Valve System with optional local indicator

Class I Division 1 Groups C, D; T4

Class II, Groups E, F, and G; Class III

Class I Zone1 AEx db ia IIB T4 Gb

Zone 21 AEx tb IIIC T135 Db

Integrated Monitoring Valve System, Model IMVS2000v2 with optional local indicator,

Ambient temperature range -40 °C to +75 °C, Type 4, 4X, 6, IP66/68

Conditions of Acceptability

1. The flameproof joints are not intended to be repaired but where necessary the original manufacturer shall be contacted for guidance and information on the dimensions of the flameproof joints.
2. The user shall be aware that all external fasteners on which the flameproof enclosure depends are stainless steel socket head cap screws class A4 -grade 70.
3. Equipment is only to be installed by manufacturer trained personnel.
4. The scope of this approval does not include any safety related function, performance or reliability of the equipment.
5. If at any time there is a conflict between the system safety provisions and any relevant local (national Or regional) requirements, the local requirements always take precedence.

Process Pressure Limitation for explosive fluids

The IMVS2000v2 has a pressure limitation for explosive fluids of 180 barg. This limitation is applicable only if the explosive fluid is in direct contact with the pressure sensors of the IMVS2000v2. If the fluid used for supplying the actuator and consequently in contact with the pressure sensors of the IMVS2000v2 is not explosive, the pressure limitation is 345 barg.

Applicable Requirements

CAN/CSA-C22.2 No. 61010-1-12	Safety Requirements for Electrical Equipment for Measurement, Control, and Laboratory Use, Part 1: General Requirements
UL Std. No. 61010-1 (3rd Edition)	Safety Requirements for Electrical Equipment for Measurement, Control, and Laboratory Use - Part 1: General Requirements
CAN/CSA-C22.2 No. 0-10 (R2015)	Canadian Electrical Code, Part II - General requirements
CAN/CSA-C22.2 No. 60079-0:15	Electrical apparatus for explosive gas atmospheres- Part 0: General requirements
CAN/CSA-C22.2 No. 60079-1:16	Explosive Atmospheres – Part 1: Equipment Protection by Flame-proof Enclosures “d”
CAN/CSA-C22.2 No 60079-11:14	Explosive atmospheres — Part 11: Equipment protection by intrinsic safety “i”
CAN/CSA-C22.2 No 60079-31:15	Explosive atmospheres — Part 31: Equipment dust ignition protection by enclosure “t”
CAN/CSA-C22.2 No.30-M1986 (2016)	Explosion-Proof Enclosures for Use in Class I Hazardous Locations
CAN/CSA-C22.2 No 25:1966 (R2014)	Enclosures for Use in Class II Groups E, F, and G Hazardous Locations
CAN/CSA C22.2 No 157	Intrinsically safe and non-incendive equipment or use in Hazardous Locations
ANSI/ISA 60079-0: Ed 6	Electrical Apparatus for Explosive Gas Atmospheres - Part 0: Equipment - General Requirements
ANSI/ISA 60079-1: Ed 6	Explosive Atmospheres - Part 1: Equipment Protection by Flame-proof Enclosures “d”
ANSI/ISA 60079-11: Ed 6.2	Explosive atmospheres - Part 11: Equipment protection by intrinsic safety “i”
ANSI/ISA 60079-31: Ed 6	Explosive Atmospheres - Part 31: Equipment Dust Ignition Protection by Enclosure “t”
FM 3600:2011	Electrical Equipment for Use in Hazardous (Classified) Locations General Requirements
FM 3615:2006	Explosionproof Electrical Equipment, General Requirements
FM 3610:2015	Intrinsically Safe Apparatus for Use in Class I, II and III, Division 1
FM 3616:2011	Dust-Ignition proof Electrical Equipment, General Requirements
CSA C22.2 No. 94.2-15 / UL50E	Enclosures for Electrical Equipment, Environmental Considerations

Section 3: Storage

Important

Not performing the following procedures will invalidate the product guarantee.

All the IMVS2000v2 leave the factory in perfect condition. When mounted on the actuator they are guaranteed by the actuator test certificate; in other cases, they are guaranteed by an individual certificate. In order to maintain these characteristics until the IMVS2000v2 is installed on site, proper attention must be observed for preservation during the storage period.

The standard plastic plugs used to protect the cable entries during the transport are not weatherproof, they just prevent the entry of undesired objects during transport: during the storage it is recommended to replace them with waterproof version.

In any case storage is recommended in a close ambient without excessive humidity.

IMVS2000v2 are weather-proof to IP66/68.

Section 4: Device Description

4.1 General Description

The IMVS2000v2 is designed to provide the Partial Stroke Test and SOV Test (in some particular configurations). SOV test grant the solenoid valve integrity verification without any actuator or valve movement, i.e.: perform the valve/actuator test and/or movement able to verify and compare (diagnostic capability) signature values with ongoing test, in particular, the continuously position verification (via encoder) and pressure verification in actuator cylinder (these two functions are always active).

The functions above described are performed without any risk of process interruption.

A valve position sensor and sensors for external pressure are embedded on the IMVS2000v2 unit: the analog output signals of the above sensors are monitored and processed by logic control cards mounted within the device: through the above signals a full control and diagnostic of every kind of valve actuator is available.

Typical applications, but not limited to, are the installation on all type of actuators, driven pneumatically or hydraulically, for ON-OFF/ESD applications.

Different versions are available for:

- single or double acting actuators,
- actuators pneumatically or hydraulically operated,
- rotary or linear actuators,
- direct installation on actuator.

4.1.1 Main Features

In the following section the main features of the IMVS2000v2 are listed. For additional details see Section 5.

POSITION SENSOR

The IMVS2000v2 is provided with an internal contactless position sensor. The position (open or close) is directly takes on the shaft connected to the actuator.

PRESSURE SENSORS

The IMVS2000v2 can manage up to three internal pressure sensors for reading the actuator (two sensors) and the pipeline (process) pressure.

CONFIGURATION-MANAGING INTERFACES

The IMVS2000v2 is provided with a powerful local operator interface, made of one 128x64 graphical OLED display and 3 push-buttons that allow entering the configuration data and visualizing the values of variables or the status of the device.

Moreover, an RS232 and a Bluetooth serial communication ports are provided for the connection with the “Biffi-Assistant” software tool (see [1] for details), to carry out parameter configuration, or variables visualization or to download the recorded event data for further analysis of pipeline behavior.

POWER SUPPLY

The IMVS2000v2 accepts a wide range power supply:

- from 19.2 Vdc to 57.6 Vdc (24 Vdc -20% to 48 Vdc to +20%).

SOVs CIRCUITS

The IMVS2000v2 can manage two independent (isolated) circuits for controlling up to two external Solenoid Valves (SOVs).

Each circuit has its own dedicated power supply (SIS) that through a relay is used to control the SOV.

DIGITAL INPUTS (Opto-isolated)

The IMVS2000v2 is provided with three opto-isolated Digital Inputs (DI) for controlling the Solenoid Valves (SOVs) and for launching a PST test.

DIGITAL OUTPUTS (Solid State Relays)

The IMVS2000v2 is provided with six isolated (solid state relay) Digital Outputs (DO):

- OPEN
- CLOSE
- COMMON FAILURE ALARM
- PST IN PROGRESS
- PST PASSED
- PST FAILED

AUTO-DIAGNOSTIC

The IMVS2000v2 monitors the status of its internal sensors (pressure and position).

ADDITIONAL BUS CARDS

The IMVS2000v2 has the possibility to use one of the following optional Bus Card:

- HART Card (HART 7)
- MODBUS Card (MODBUS-RTU)

4.2 Identification of the Main Parts

In this section, only the main parts of the IMVS2000v2 are shown. Refer to the “PARTS LIST” paragraph, for a full list of the IMVS2000v2 parts.

The IMVS2000v2 device is composed by three main parts:

- a. a base cover with a glass window to display a mechanical visual indicator,
- b. a local interface cover with three push-buttons and a glass window to show the indication of an internal display,
- c. a sensor manifold to allocate the pneumatic/hydraulic sensors with relevant connections and cable entries for electrical wirings.

Figure 1



The screws fixing the enclosure covers are made in Stainless Steel Class A4, grade 70, with a minimum yield strength 450 N/mm².

The shaft, which transmits the movement from the valve to the internal position sensor, is supported by a bush mounted on the sensors' manifold and blocked on the external diameter with LOCTITE 638 (or equivalent).

The various explosion-proof joint surfaces can be lubricated with Aeroshell Grease.

Figure 2

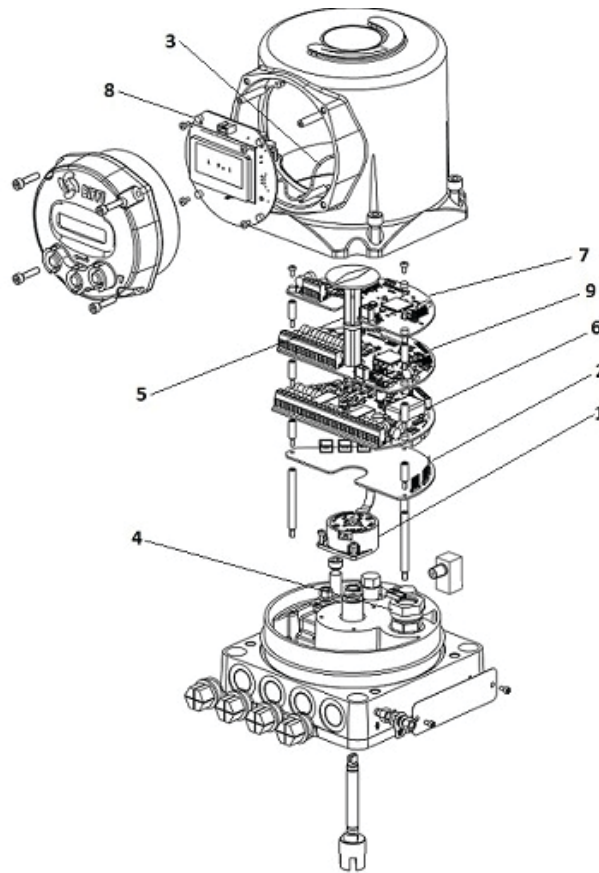

Pos.	Description
1	Position Sensor Assembly
2	Barrier Card
3	Display / Logic Cable
4	Pressure Sensor
5	Position Indicator
6	Base Power Card
7	Bus Card (OPT.)
8	Display Card
9	Logic Card

4.3 Technical Specifications

Table 1.

Device Power Supply (#)	
Supply Voltage Range	19.2 Vdc - 57.6 Vdc (24 Vdc -20% - 48 Vdc +20%) 19.2 Vdc – 35 Vdc for CSA/CSAus device
Maximum Device Current Consumption	125 mA @ 24 Vdc (3 W) 62.5 mA @ 48 Vdc (3 W)
Galvanic Insulation from Logic	Yes

SOVs Power Supply (SIS A – SIS B) (#)	
Maximum allowed Voltage	up to 57.6 Vdc
Maximum switching power (resistive load)	up to 1 A
Galvanic Insulation from Logic	Yes

Digital Inputs (#)	
Maximum OFF signal	9 Vdc
Maximum ON signal	19.2 Vdc (24 -20%)
Maximum ON signal	57.6 Vdc (48 +20%) 35Vdc for CSA/CSAus device
Current Consumption	min. 2.0 mA - max.11 mA
Galvanic Insulation from Logic	YES
Galvanic Insulation from others DIs	YES

Digital Outputs (SPST solid state dry contact) (#)	
Maximum allowed Voltage	up to 57.6 Vdc up to 35 Vdc for CSA/CSAus device
Maximum allowed Current	up to 0.5 A
Galvanic Insulation from Logic	Yes
Galvanic Insulation from others DOs	Yes

Pressure Sensors Range	
Option 1	up to 10 barg (145 psig) (*)
Option 2	up to 100 barg (1450 psig)
Option 3	up to 200 barg (2900 psig)
Option 4	up to 400 barg (5800 psig) (**)

RS232 (Configuration Port)	
Baud rate	115200 bps
Parity Bit	Even
Stop Bit	1
Hardware flow control	Off
Distance (cable length)	Max. 10 meters

Bluetooth (Configuration Port)	
Baud rate	115200
Parity Bit	None
Stop Bit	1
Hardware flow control	On
Distance	Max. 10 meters

Various Characteristics	
Operating Ambient Temperature	from -40° C up to +75° C
Expected Lifetime	10 years
Weight	16,4 kg

Stroking Time Limits (***)	
Min. Actuator Stroking Time	2 sec.
Max. Actuator Stroking Time	300 sec.
Max. Ratio between Op. and Cl. times	10 (****)

Modbus Rtu (optional card) (****)	
Transmission Technology	RS485
Baud rate (configurable)	600,1200,2400,4800,9600,19200,38400 bps
Parity Bit (configurable)	Even, Odd, None
Stop Bit (according to Parity Bit)	1, 2
Galvanic Insulation from Logic	Yes

4-20 mA Analog Output + HART (optional card) (*****)	
Feedback Signal	Pressure or Position
Output Current Range	4-20 mA
Maximum Load (cable+resistor)	300 ohm
External Power Supply Voltage	21.6 - 26.4Vdc – max 21 mA
Galvanic Insulation from Logic	Yes

Notes:

- (*) Consult Factory for availability.
- (**) Consult Factory for applications over 345 barg.
- (***) Contact Biffi for the availability of applications that do not respect these ranges.
- (****) Ratio greater than 5 affects the accuracy of the PST.
(particularly for pneumatic application)
- (*****) See [3] for details.
- (*****) See [2] for details.
- (#) For CSA/CSAus devices must be supplied from a limited energy source.
(voltage available is to be limited to 35 Vdc)

Section 5: Working Principle and Detailed Description

5.1 Working Principle

The IMVS2000v2 is a PST device designed to diagnose an actuator/valve system. It directly manages the SOVs of the control panel (up to two). It offers the possibility to check all the parts of the system: Valve, Actuator and SOVs (Solenoid Valves).

The IMVS2000v2 can automatically find the mechanical stoppers through the “Calibration” command (see Section 5.1.1 for details).

The IMVS2000v2 can perform both Partial Stroke (PST) and to the Full Stroke (FST) in opening and closing and also a SOV Test (in some particular configurations).

For every FST and PST the IMVS2000v2 stores the following data:

- Time (seconds)
- Pressure 1 (bar or psi) – pressure sensor S1 (*)
- Pressure 2 (bar or psi) – pressure sensor S2 (**)
- Process pressure (bar or psi) – pressure sensor S3 (***)
- Position (%)
- Pr. 1 – Pr. 2 | - absolute value of the difference between Pressure 1 and Pressure 2 (**)

It is possible to set tolerances on time, pressure and position of both FST and PST. During the commissioning procedure (see 10.7) the IMVS2000v2 stores:

- the “ideal” opening FST and closing FST (**Baseline Signature**)
- the “ideal” PST (**Baseline PST**)

The further FSTs (**Maintenance Signature, Opening FST or Closing FST**) are compared with the Baseline Signature and further PSTs (**Manual PST**). It is possible to set tolerances on time, pressure and position of both FST and PST and if the measured values compared to the Baseline ones, overtake these settings the IMVS2000v2 generates dedicated alarms (see Sections 5.2.7 and 8 for details).

See Sections 5.1.2, 5.1.6, 5.1.8, and 5.1.9 for details about Signature, FST and PST.

The IMVS2000v2 offers the possibility to monitor:

- Actuator Pressure
- Actuator Position
- Pipeline Pressure (Pressure Sensor S3)
- PST cycles number
- FST cycles number
- Sensors Status (pressure and position)

Dedicated alarms are provided (see Sections 5.2.7 and Section 8 for details).

(*): if the pressure sensor 1 is enabled.

(**): if the pressure sensor 2 is present and enabled.

(***): if the process pressure sensor is present and enabled.

5.1.1 Calibration

The Calibration is a mandatory operation for using the IMVS2000v2. It must be performed as first step of the Commissioning Procedure (see Section 10.7 for details). To perform the Calibration, the IMVS2000v2 must be correctly connected and configured and it must be able to control the valve/ actuator system.

The Calibration is an operation that allows the IMVS2000v2 to find the mechanical stoppers. The Calibration operation consists of: two Opening FST and two Closing FST and it is “automatically managed by the IMVS2000v2.

During the execution of the Calibration the Digital Inputs status is not considered. The status of the Calibration is stored in a dedicated parameter. The Calibration command can be inhibited (see Section 6 for details). A new Calibration cancels all the stored signatures, FSTs and PSTs data.

The Calibration can be launched by the following interfaces:

- Local Operator Interface
- Biffi Assistant (Bluetooth and RS232)
- Bus Interface

For using the IMVS2000v2 at its own best, it is suggested to perform the Calibration in the following conditions:

- Pressures and position stable
- Valve in its “normal” working position (ex. Open position for a “fail to close” actuator)

5.1.2 Signature

There are two different types of signature:

- Baseline Signature
- Maintenance Signature

To perform the Baseline Signature and the Maintenance Signature, the IMVS2000v2 must be correctly connected and configured and it must be able to control the valve/actuator system. The Baseline Signature can be performed only if a Calibration is already successfully executed. The Maintenance Signature can be performed only if a Baseline Signature is already successfully executed. A new Baseline Signature cancels all the stored Maintenance Signatures, FSTs and PSTs data.

The Baseline Signature and the Maintenance Signature consist of one Opening FST and one Closing FST and they are “automatically” managed by the IMVS2000v2; at the end of the operation the valve/ actuator system comes back to the starting position.

During the execution of the Baseline Signature or of the Maintenance Signature the Digital Inputs status is not considered.

The Baseline Signature is a mandatory operation for using the IMVS2000v2. It must be performed as second step of the Commissioning Procedure (see 10.7 for details).

It allows the IMVS2000V2 to record the reference times and pressures of the Opening FST and of the Closing FST.

The Maintenance Signature allows the IMVS2000V2 to record the times and pressures of the Opening FST and of the Closing FST; these values are compared to the ones of the Baseline Signature and if they overtake the set tolerances, dedicated alarm are generated (see Sections 5.2.7 , 8, 5.1.6 and 5.1.8 for details).

The Baseline Signature and the Maintenance Signature can be launched by the following interfaces:

- Local Operator Interface
- Biffi Assistant (Bluetooth and RS232)
- Bus Interface

To use the IMVS2000v2 at its own best, it is suggested to perform the Baseline and Maintenance Signatures in the following conditions:

- pressures and position stable
- valve in its “normal” working position (ex. Open position for a “fail to close” actuator)
Opening and Closing FST (Digital Input)

5.1.3 Opening and Closing FST (External Source)

It is possible to open and close the valve/actuator through the Digital Inputs of the IMVS2000v2. The IMVS2000v2 reads the status of the Digital Input and controls the SOVs to move the valve actuator (see Section 5.2.2 for details).

The IMVS2000v2 records all the complete Opening FST and Closing FST (graphs are stored into the device memory) and it is possible to compare the measured pressures and times with the ones of the Baseline Signature, to obtain a relevant diagnostic (see Sections 5.2.7, 8, 5.1.6, 5.1.8 and 5.2.8.1 for details).

To open and close the valve/actuator through the IMVS2000v2, it must be correctly connected and configured and it must be able to control the valve/actuator system. It is possible to store the FST data, only if a Baseline Signature is already successfully executed.

To use the IMVS2000v2 at its own best, it is recommended to open and close the actuator when pressures and position are stable (see Section 5.2.8.1 for details).

The IMVS2000v2 continuously monitors the position of the valve/actuator. If a complete Opening FST or a complete Closing FST is performed without using the IMVS (i.e. external SOV not controlled by the IMVS2000v2), the device records the graph of the FST.

The data of this kind of FST are not compared with the ones of the Baseline Signature.

It is possible to store the FST data, only if a Baseline Signature is already successfully executed.

Device, the record of is inhibited for a time equal to (“B. Op. B. T.” + “B. Op. T. T.”, “B. CL. B. T.” + “B. Op. B. T.”)* 1.2, for avoiding false registrations.

5.1.4 PST

There are two different types of PST:

- Baseline PST
- Manual PST

To perform the Baseline PST and the Manual PST, the IMVS2000v2 must be correctly connected and configured and it must be able to control the valve/actuator system.

The Baseline PST can be performed only if a Baseline Signature is already successfully executed.

The Manual PST can be performed only if a Baseline PST is already successfully executed.

The Baseline PST and the Manual PST consist of one partial closing or partial opening stroke, when the valve/actuator reaches the PST setpoint (configurable) it comes back to the starting position. The PST is “automatically managed by the IMVS2000v2; at the end of the operation the valve/actuator system comes back to the starting position.

During the execution of the Baseline and Manual PST the Digital Inputs status is not considered.

A new Baseline PST cancels all the stored Manual PSTs data.

The Baseline PST allows to record the reference times and pressures of the partial opening stroke or of the partial closing stroke.

The Manual PST allows recording the times and pressures of the partial opening stroke or of the partial closing stroke; these values are compared with the ones of the Baseline PST and if they overtake the set tolerances, dedicated alarm are generated (see Sections 5.2.7, 8 and 5.1.9 for details).

The Baseline PST and the Manual PST can be launched by the following interfaces:

- Local Operator Interface
- Biffi Assistant (Bluetooth and RS232)
- Bus Interface
- “PST Control” Digital Input (only for Manual PST)

To take the full operational capability of the IMVS2 at its own best, it is suggested to perform the Baseline and Manual PSTs in the following conditions:

- pressures and position stable.
- valve in its “normal” working position (e.g. Open position for a “fail to close” actuator)

5.1.5 SOVs Test

The IMVS2000v2 can control up two external SOVs with independent and isolated circuits.

The IMVS2000v2 can perform the SOV test to check the SOV integrity if:

- A single SOV is present
- Two SOVs are connected in series

See 6.2 for details.

The SOV test consists of managing one or two SOVs to generate a pressure decrease inside the cylinder (detected by pressure sensor) without generating the actuator movement

There are four possible configurations (see 6 for details):

1. Configuration X

- “Act. Mode” = “Single” or “Double-S”
- “SOVs Qty” = “Series”
- “PST Ser. SOVs” = “Both”
- “Pr. S. 1-2” ≠ “None”
- “PST En.” = “Yes”

The SOV test is executed during the PST command (see 5.1.9.1 for details). The two SOVs are involved in all the command of the IMVS2000v2 (Calibration, Signatures and PST).

2. Configuration Y

- “Act. Mode” = “Single” or “Double-S”
- “SOVs Qty” = “Simplex”
- “PST Ser. SOVs” = “Both”
- “Pr. S. 1-2” ≠ “None”
- “PST En.” = “Yes”

The SOV TEST can be performed by using a dedicated input (SOLENOID B CONTROL) or a dedicated parameter (RL B CMD).

The SOV TEST is executed only on to the SOV B.

The SOV B is not involved in the other commands of the IMVS2000v2 (Calibration, Signatures and PST), for these commands the SOV A is used.

In this configuration:

- SOV A is used for the PST
- SOV B is just used for its own SOV TEST.
- The SOV TEST can be performed only if a Baseline PST is already successfully done.

See Errore. L'origine riferimento non è stata trovata. for details.

3. Configuration Z

- “Act. Mode” = “Single” or “Double-S”
- “SOVs Qty” = “Simplex”
- “PST Ser. SOVs” = “One”
- “Pr. S. 1-2” ≠ “None”
- “PST En.” = “No”
- “PST Pos. %” = 0.0%
- “PST Pres. %” = 0%
- “PST Time %” = 0%
- “Al. PSA En.” ≠ “No”

4. Configuration T

- “Act. Mode” = “Single” or “Double-S”
- “SOVs Qty” = “Series”
- “PST Ser. SOVs” = “Both”
- “Pr. S. 1-2” ≠ “None”
- “PST En.” = “No”
- “PST Pos. %” = 0.0%
- “PST Pres. %” = 0%
- “PST Time %” = 0%
- “Al. PSA En.” ≠ “No”
- “Al. PSB En.” ≠ “No”

The SOV TEST can be performed by using a dedicated input (PST CONTROL) or the dedicated parameters (BASELINE PST CMD or MANUAL PST CMD).

The SOV TEST is executed on both solenoid valves and it can be completed only if a Baseline Signature is already successfully done.

This configuration is available from Logic Card FW Rev. 1.00.01

This configuration is available from Logic Card FW Rev. 1.00.01.
See Section 10 for details.

5.1.6 Closing FST Details

The figure below shows an example of Closing FST.

Figure 4

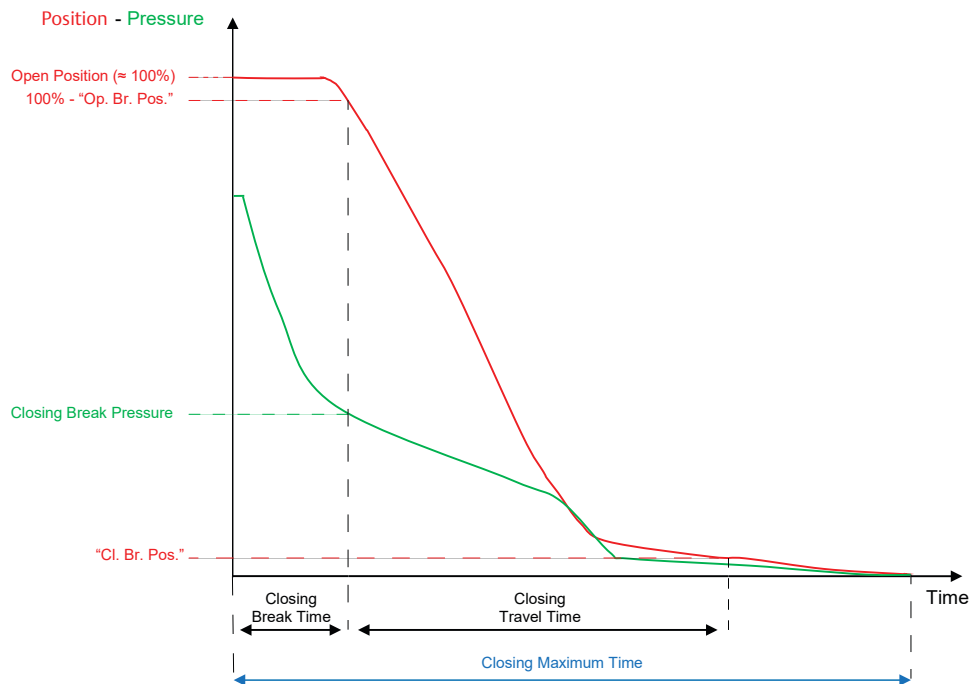

The position is expressed as % of the Open Position (100% = Open Position, 0% = Closed Position).

The Closing Maximum Time is the total time of the Closing FST Graph. It is automatically calculated by the IMVS2000v2 (set equal to the Calculated Closing Time).

See Section 5.2.8 for details.

For the Double Acting actuator, the Closing Break Pressure is expressed as the absolute value of the difference between the Pressure 1 (pressure sensor S1) and the Pressure 2 (pressure sensor S2).

Considering that "Op. Br. Pos" and "Cl.Br. Pos" are fixed to 3%.

- Closing Break Time = time to go from Open Position to 97%
- Closing Break Pressure = pressure measured at 97%
- Closing Travel Time = time to go from 97% to 3%

If the starting position is not higher than 97% the Closing Break Time, the Closing Travel Time and the Closing Break Pressure are set to 0. If at the end of the Closing FST the position is higher than 3%, the Closing Travel Time is set to 0. The CLCT alarm, if enabled, is generated (see Sections 5.2.7 and 8 for details).

The Closing Break Time, the Closing Travel Time and the Closing Break Pressure of the Closing FST of the Baseline Signature are compared to the ones of the last Closing FST and if they do not respect the set tolerances, dedicated alarms can be activated (see Sections 5.2.7 and 8 for details).

5.1.7 Opening FST Details

The figure below shows an example of Opening FST.

Figure 5

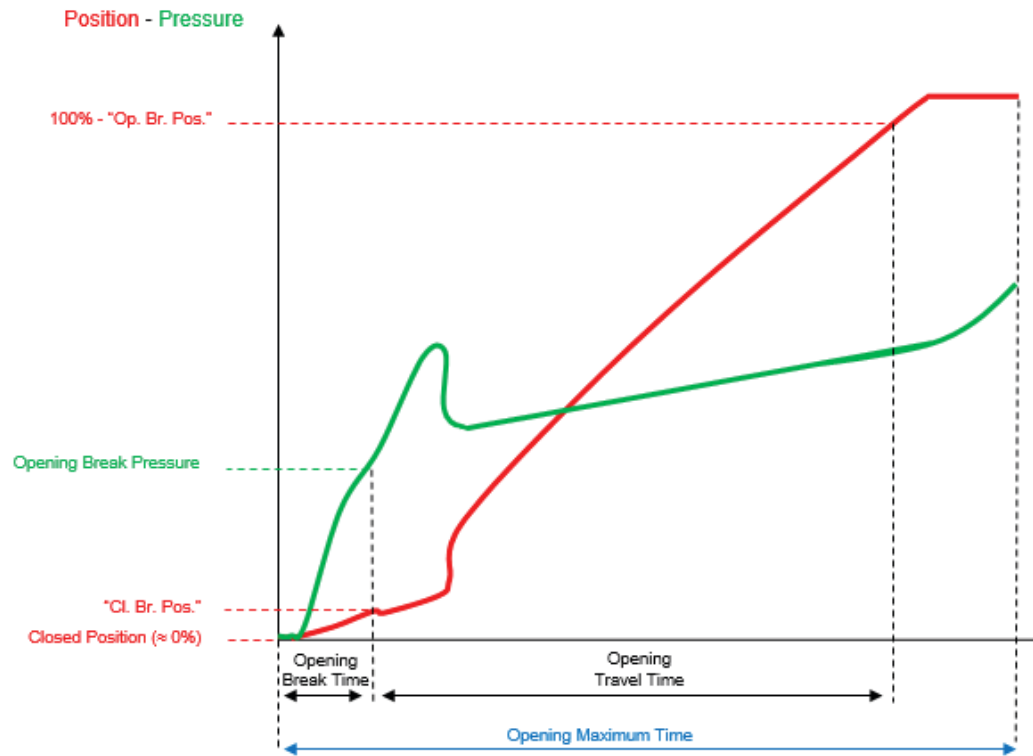

The position is expressed as % of the Open Position (100% = Open Position, 0% = Closed Position).

The Opening Maximum Time is the total time of the Opening FST Graph. It is automatically calculated by the IMVS2000v2 (set equal to the Calculated Opening Time). See 5.2.8 for details.

For the Double Acting actuator, the Opening Break Pressure is expressed as the absolute value of the difference between the Pressure 1 (pressure sensor S1) and the Pressure 2 (pressure sensor S2).

Considering that “Op. Br. Pos” and “Cl.Br. Pos” are fixed to 3%.

- Opening Break Time = time to go from Closed Position to 3%
- Opening Break Pressure = pressure measured at 3%
- Opening Travel Time = time to go from 3% to 97%

If the starting position is not lower than 3% the Closing Break Time, the Closing Travel Time and the Closing Break Pressure are set to 0. If at the end of the Opening FST the position is lower than 97%, the Opening Travel Time is set to 0. The OPCT alarm, if enabled, is generated (see Sections 5.2.7 and 8 for details).

The Opening Break Time, the Opening Travel Time and the Opening Break Pressure of the Closing FST of the Baseline Signature are compared to the ones of the last Closing FST and if they do not respect the set tolerances, dedicated alarms can be activated (see Sections 5.2.7 and 8 for details).

5.1.8 PST and SOV TEST Details

The figure below shows an example of Partial Closing Stroke.

Figure 6

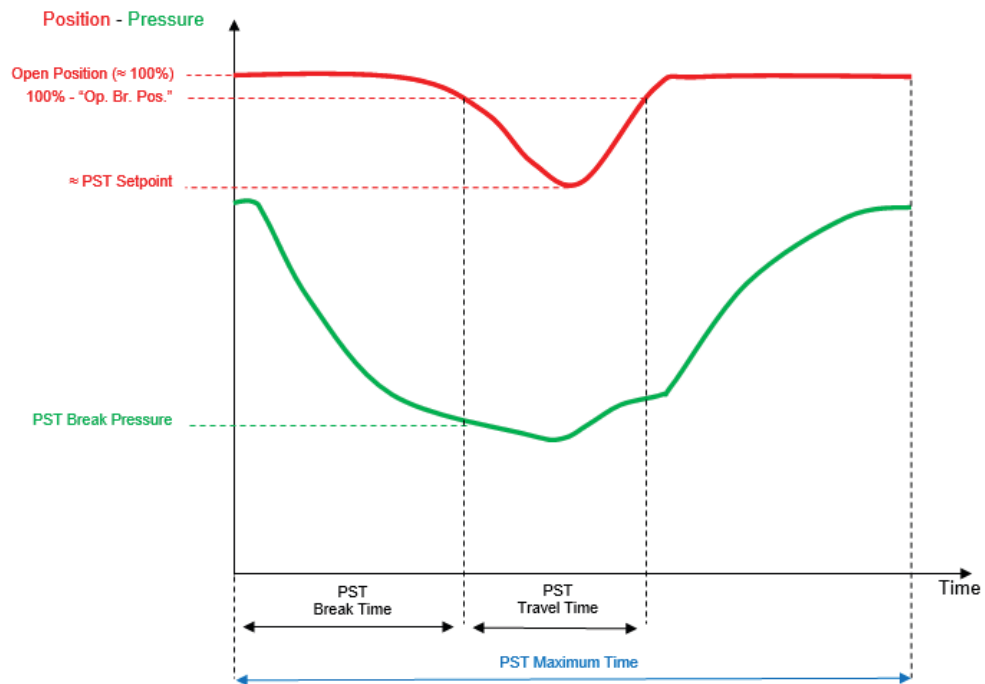

The position is expressed as % of the Open Position (100% = Open Position, 0% = Closed Position).

The PST Maximum Time is the total time of the PST Graph. It is automatically calculated by the IMVS2000v2 (set equal to the Calculated PST Time). See Section 5.2.8 for details.

For the Double Acting actuator, the Opening Break Pressure is expressed as the absolute value of the difference between the Pressure 1 (pressure sensor S1) and the Pressure 2 (pressure sensor S2).

Considering that "Op. Br. Pos" and "Cl.Br. Pos" are fixed to 3%.

- PST Break Time = time to go from Open Position to 97%
- PST Break Pressure = pressure measured at 97%
- PST Travel Time = time to go from 97% to 97%, passing for the setpoint.

If the starting position is not higher than 97% the PST Break Time, the PST Travel Time and the PST Break Pressure are set to 0. If at the end of the PST the position is lower than 97%, the PST Travel Time is set to 0. The PSCT alarm, if enabled, is generated (see Sections 5.2.7 and 8 for details).

The PST Break Time, the PST Travel Time and the PST Break Pressure of the Baseline PST are compared to the ones of the last Manual PST and if they do not respect the set tolerances, dedicated alarms can be activated (see Sections 5.2.7 and 8 for details).

The Partial Closing Stroke can be performed only if the actuator is open and if the IMVS2000v2 is configured as fail to close ("Fail Mode" = "CL").

The figure below shows an example of Partial Opening Stroke.

Figure 7

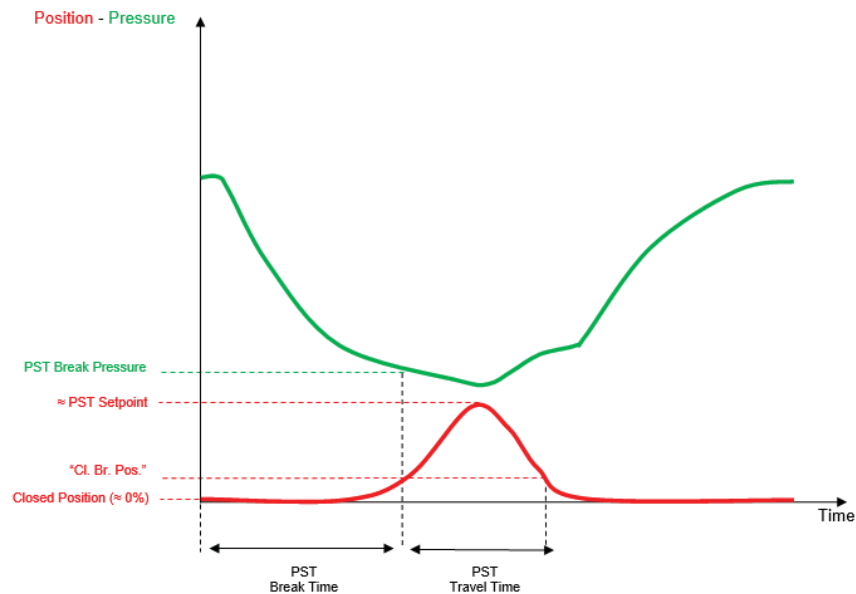

The position is expressed as % of the Open Position (100% = Open Position, 0% = Closed Position).

The PST Maximum Time is the total time of the PST Graph. It is automatically calculated by the IMVS2000v2 (set equal to the Calculated PST Time). See Section 5.2.8 for details.

For the Double Acting actuator, the Opening Break Pressure is expressed as the absolute value of the difference between the Pressure 1 (pressure sensor S1) and the Pressure 2 (pressure sensor S2).

Considering that “Op. Br. Pos” and “Cl.Br. Pos” are fixed to 3%.

- PST Break Time = time to go from Closed Position to 3%
- PST Break Pressure = pressure measured at 3%
- PST Travel Time = time to go from 3% to 3%, passing for the setpoint

If the starting position is not lower than 3% the PST Break Time, the PST Travel Time and the PST Break Pressure are set to 0. If at the end of the PST the position is higher than 3%, the PST Travel Time is set to 0. The PSCT alarm, if enabled, is generated (see Sections 5.2.7 and 8 for details).

The PST Break Time, the PST Travel Time and the PST Break Pressure of the Baseline PST are compared to the ones of the last Manual PST and if they do not respect the set tolerances, dedicated alarms can be activated (see Sections Sections 5.2.7 and 8 for details).

The Partial Closing Stroke can be performed only if the actuator is closed and if the IMVS2000v2 is configured as fail to open (“Fail Mode” = “OP”).

5.1.8.1 PST + SOV TEST Details

The figure below shows an example of Partial Closing Stroke on a system with two SOVs in series (see for example Configuration C on paragraph 9.2.3) where one SOV is used to perform the PST and the other SOV is tested through a SOV TEST.

This kind of test is performed in case of the following settings (see 5.1.6):

- “Act. Mode” = “Single” or “Double-S”
- “SOVs Qty” = “Series”
- “PST Ser. SOVs” = “Both”
- “Pr. S. 1-2” ≠ “None”

Figure 8

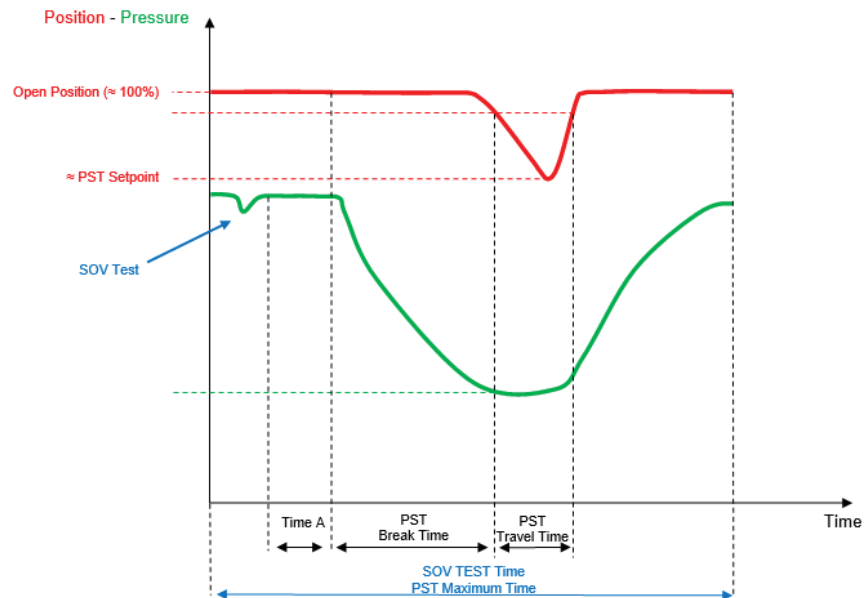

Time A: time from the end of the SOV test and the beginning of the PST test. It is variable time determined by the IMVS2000v2.

The IMVS2000v2, correctly configured, allows testing two SOVs in series in a unique PST.

During the first PST, the first SOV (SOVA) is briefly used for a short time to generate a pressure drop inside the cylinder (detected by pressure sensor) without generating the actuator movement.

The second SOV (SOVB) is used to control the valve/actuator to get the setpoint of the PST.

During the next PST the IMVS2000v2 controls the solenoid valve in the opposite sequence: SOVB is tested by generating a cylinder pressure decrease only and the SOVA is used to get the setpoint of the PST. After each performed PST, the IMVS2000v2 reverses the solenoid valve test sequence.

It is possible to configure the IMVS2000v2 to test the SOVs individually (“PST Ser. SOVs” = “One”)

During the first PST the SOVA is used to get the setpoint of the PST and the SOVB is not tested.

During the next PST the SOVB is used to get the setpoint of the PST and the SOVA is not tested.

After each performed PST, the IMVS2000v2 reverses the solenoid valve test sequence.

The way to perform the PST of the SOVs in series is determined by the “PST Ser. SOVs” parameter. See 6 for details dealing with the IMVS2000v2 configuration.

5.1.8.2 SOV B TEST Details

The figure below shows an example of SOV TEST on the SOV B on a system of two SOVs in series (see for example Configuration C on paragraph 9.2.3). This kind of test is performed in case of the following settings (see Section 5.1.6):

- “Act. Mode” = “Single” or “Double-S”
- “SOVs Qty” = “Simplex”
- “PST Ser. SOVs” = “Both”
- “Pr. S. 1-2” ≠ “None”

Figure 9

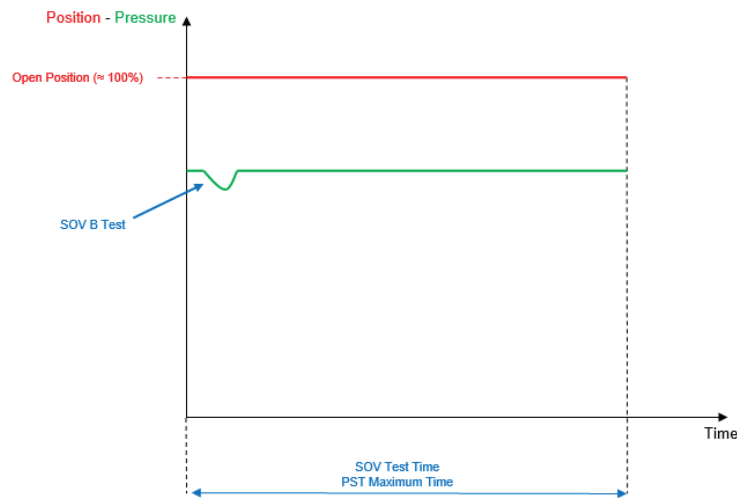

During the SOV TEST, the SOV B is briefly used for a short period of time to generate a pressure drop inside the cylinder (detected by pressure sensor) without generating the actuator’s movement.

The “SOV TEST Time” is automatically set by the IMVS2000v2.

In this configuration:

- SOV A is used for the PST
- SOV B is just used for its own SOV TEST (picture above).

The SOV TEST is executed only on to the SOV B.

The SOV B is not involved in the other commands of the IMVS2000v2 (Calibration, Signatures and PST), for these commands the SOV A is used.

“PST St.” doesn’t describe the result of the last “SOV B TEST.”

If the command is received, but:

- “Cal. Status” ≠ “Passed” or
- “Base. S. St.” ≠ “Passed” or
- “B. PST St.” ≠ “Passed” or
- “Pr. S. 1-2” = “None” or

Then:

- The command is not executed
- The PSB Alarm is activated (if enabled)
- The graph is not stored

If the command is received, but:

- “Cal. Status” = “Passed” and “CAL Alarm” is active or
- “POS Alarm” is active or
- “HSP Alarm” is active or
- “LSP Alarm” is active or
- The start position is not valid

Then:

- The command is not executed
- The PSB Alarm is activated (only if the start position is not valid)
- The graph is not stored

If a problem is verified during the SOV B TEST execution:

- The PSB Alarm is activated (if enabled)
- A new graph is stored (the Status is “Failed”)

If the SOV B TEST is successfully executed:

- The PSB Alarm is cleared
- A new graph is stored (the Status is “Passed”)

5.1.8.3 SOV A TEST Details

Available from Logic Card FW Revision 1.00.01.

The figure below show an example of a SOV TEST on the SOV A on a single SOVs configuration (see for example Configuration A on paragraph 9.2.1).

This kind of test is performed in case of the following settings (see Section 5.1.6):

- “Act. Mode” = “Single” or “Double-S”
- “SOVs Qty” = “Simplex”
- “PST Ser. SOVs” = “One”
- “Pr. S. 1-2” ≠ “None”
- “PST En.” = “No”
- “PST Pos %” = 0.0%
- “PST Pres. %” = 0%
- “PST Time %” = 0%

Figure 10

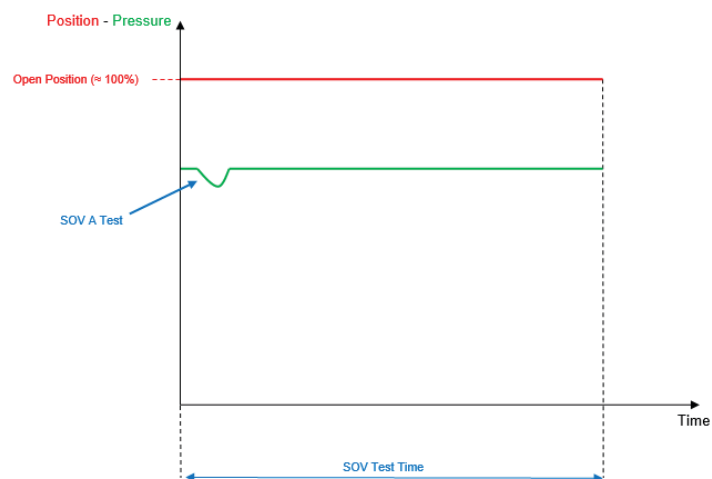

During the SOV TEST, the SOV A is briefly used for a short period of time to generate a pressure drop inside the cylinder (detected by pressure sensor) without generating the actuator’s movement.

The “SOV TEST Time” is automatically set by the IMVS2000v2.

The SOV A TEST is executed only on to the SOV A.

To perform the SOV A TEST, the following commands must be successfully executed:

- Calibration
- Baseline Signature

There are two different types of “SOV A Test”:

- Baseline SOV A Test
- SOV A Test

The “Baseline SOV A Test” can be performed by using “Baseline PST” command.

“B. PST St.” describes the result of the last Baseline SOV A Test.

“B. PST Date” and “B. PST Time” indicate the date and the time of the last Baseline SOV A Test.

If the “Baseline SOV A Test” command is received, but:

- “Cal. Status” ≠ “Passed” or
- “Base. S. St.” ≠ “Passed” or
- “Pr. S. 1-2” = “None” or
- “Al. PSA En.” = “No”

Then:

- The command is not executed
- “B. PST St.” assumes the value “Conf. Err.”
- “B. PST Date” and “B. PST Time” assume the current date and time values
- The DO PST PASSED contact is opened
- The DO PST FAILED contact is closed
- The graph is not stored

If the “Baseline SOV A Test” command is received, but:

- “Cal. Status” = “Passed” and “CAL Alarm” is active or
- “POS Alarm” is active or
- “HSP Alarm” is active or
- “LSP Alarm” is active or
- The start position is not valid

Then:

- The command is not executed
- “B. PST St.” assumes the value “Failed”
- “B. PST Date” and “B. PST Time” assume the current date and time values
- The PSA Alarm is activated
- The DO PST PASSED contact is opened
- The DO PST FAILED contact is closed
- The graph is not stored

If a “Baseline SOV A Test” is executed, all previous “SOV A TEST” are cleared.

The “SOV A Test” can be executed only if the “Baseline SOV A Test” is successfully executed.

The “SOV A Test” can be performed by using “Manual PST” command or DI “PST CONTROL.”

“PST St.” describes the result of the last “SOV A TEST.”

“M. PST Date” and “M. PST Time” indicate the date and the time of the last SOV A Test.

If the command is received, but:

- “Cal. Status” ≠ “Passed” or
- “Base. S. St.” ≠ “Passed” or
- “B. PST St.” ≠ “Passed” or
- “Pr. S. 1-2” = “None” or
- “Al. PSA En.” = “No”

Then:

- The command is not executed
- “PST St.” assumes the value “Conf. Err.”
- “M. PST Date” and “M. PST Time” assume the current date and time values
- The DO PST PASSED contact is opened
- The DO PST FAILED contact is closed
- The graph is not stored

If the “SOV A Test” command is received, but:

- “Cal. Status” = “Passed” and “CAL Alarm” is active or
- “POS Alarm” is active or - “HSP Alarm” is active or
- “LSP Alarm” is active or
- The start position is not valid

Then:

- The command is not executed
- “PST St.” assumes the value “Failed”
- “M. PST Date” and “M. PST Time” assume the current date and time values
- The PSA Alarm is activated
- The DO PST PASSED contact is opened
- The DO PST FAILED contact is closed
- The graph is not stored

If a problem is verified during the SOV A TEST execution:

- "PST St." assumes the value "Failed"
- "M. PST Date" and "M. PST Time" assume the current date and time values
- The PSA Alarm is activated
- The DO PST PASSED contact is opened
- The DO PST FAILED contact is closed
- A new graph is stored (the Status is "Failed")

If the SOV A TEST is successfully executed:

- "PST St." assumes the value "Passed"
- "M. PST Date" and "M. PST Time" assume the current date and time values
- The PSA Alarm is cleared
- The DO PST PASSED contact is closed
- The DO PST FAILED contact is opened
- A new graph is stored (the Status is "Passed")

5.1.8.4 SOV A and SOV B TEST Details

Available from Logic Card FW Rev. 1.00.01.

The figure below shows an example of SOVs TEST on SOV A and SOV B on a system of two SOVs in series (see for example Configuration C on paragraph 9.2.3).

This kind of test is performed in case of the following settings (see Section 5.1.6):

- "Act. Mode" = "Single" or "Double-S"
- "SOVs Qty" = "Series"
- "PST Ser. SOVs" = "Both"
- "Pr. S. 1-2" ≠ "None"
- "PST En." = "No"
- "PST Pos %" = 0.0%
- "PST Pres. %" = 0%
- "PST Time %" = 0%
- "Al. PSA En." ≠ "No"
- "Al. PSB En." ≠ "No"

Figure 11

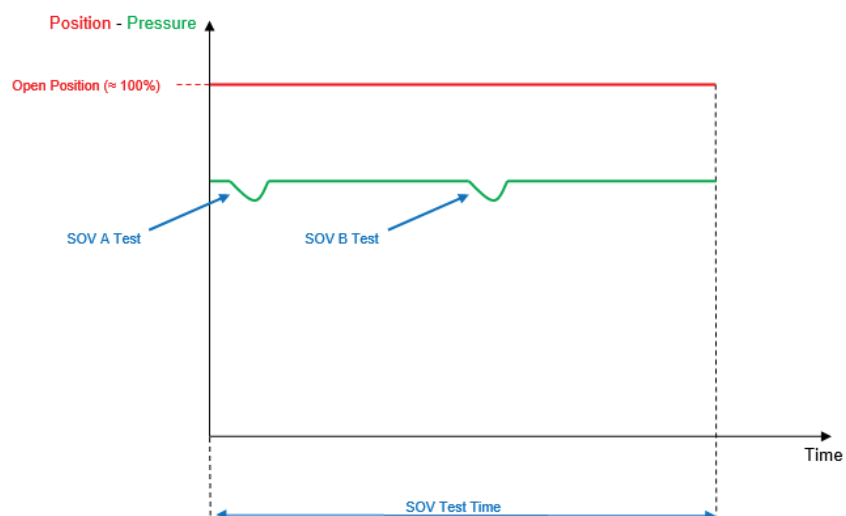

During the SOV TEST, the SOV A and the SOV B are briefly used for a short period of time to generate a pressure drop inside the cylinder (detected by pressure sensor) without generating the actuator movement.

The "SOV TEST Time" is automatically set by the IMVS2000v2.

The first SOV tested is always the SOV A.

If a problem is verified during the test on the SOV A, the test on the SOV B is executed anyway.

During the SOV TEST, the SOV A and the SOV B are briefly used for a short period of time to generate a pressure drop inside the cylinder (detected by pressure sensor) without generating the actuator movement.

The "SOV TEST Time" is automatically set by the IMVS2000v2.

The first SOV tested is always the SOV A.

If a problem is verified during the test on the SOV A, the test on the SOV B is executed anyway.

To perform the SOV A – SOV B TEST, the following commands must be successfully executed:

- Calibration
- Baseline Signature

There are two different types of "SOV A and SOV B Test":

- Baseline SOV A – SOV B Test
- SOV A – SOV B Test

The "Baseline SOV A – SOV B Test" can be performed by using "Baseline PST" command.

"B. PST St." describes the result of the last Baseline SOV A – SOV B Test.

"B. PST Date" and "B. PST Time" indicate the date and the time of the last Baseline SOV A – SOV B Test.

If the "Baseline SOV A – SOV B Test" command is received, but:

- "Cal. Status" ≠ "Passed" or
- "Base. S. St." ≠ "Passed" or
- "Pr. S. 1-2" = "None" or
- "Al. PSA En." = "No" or
- "Al. PSB En." = "No"

Then:

- The command is not executed
- "B. PST St." assumes the value "Conf. Err."
- "B. PST Date" and "B. PST Time" assume the current date and time values
- The DO PST PASSED contact is opened
- The DO PST FAILED contact is closed
- The graph is not stored

If the "Baseline SOV A – SOV B Test" command is received, but:

- "Cal. Status" = "Passed" and "CAL Alarm" is active or
- "POS Alarm" is active or
- "HSP Alarm" is active or
- "LSP Alarm" is active or
- The start position is not valid

Then:

- The command is not executed
- "B. PST St." assumes the value "Failed"
- "B. PST Date" and "B. PST Time" assume the current date and time values
- The PSA Alarm and PSB Alarm are activated
- The DO PST PASSED contact is opened
- The DO PST FAILED contact is closed
- The graph is not stored

If a "Baseline SOV A – SOV B Test" is executed, all previous "SOV A – SOV B TEST" are cleared.

The "SOV A – SOV B Test" can be executed only if the "Baseline SOV A – SOV B Test" is successfully executed.

The "SOV A – SOV B Test" can be performed by using "Manual PST" command or DI "PST CONTROL."

"PST St." describes the result of the last "SOV A – SOV B TEST."

"M. PST Date" and "M. PST Time" indicate the date and the time of the last SOV A – SOV B Test.

If the command is received, but:

- "Cal. Status" ≠ "Passed" or
- "Base. S. St." ≠ "Passed" or
- "B. PST St." ≠ "Passed" or
- "Pr. S. 1-2" = "None" or
- "Al. PSA En." = "No" or
- "Al. PSB En." = "No"

Then:

- The command is not executed
- "PST St." assumes the value "Conf. Err."
- "M. PST Date" and "M. PST Time" assume the current date and time values
- The DO PST PASSED contact is opened
- The DO PST FAILED contact is closed
- The graph is not stored

If the "SOV A – SOV B Test" command is received, but:

- "Cal. Status" = "Passed" and "CAL Alarm" is active or
- "POS Alarm" is active or
- "HSP Alarm" is active or
- "LSP Alarm" is active or
- The start position is not valid

Then:

- The command is not executed
- "PST St." assumes the value "Failed"
- "M. PST Date" and "M. PST Time" assume the current date and time values
- PSA Alarm and PSB Alarm are activated
- The DO PST PASSED contact is opened
- The DO PST FAILED contact is closed
- The graph is not stored

If a problem is verified during the SOV A – SOV B TEST execution:

- "PST St." assumes the value "Failed"
- "M. PST Date" and "M. PST Time" assume the current date and time values
- PSA Alarm is activated if a problem is detected during the SOV A Test
- PSB Alarm is activated if a problem is detected during the SOV B Test
- The DO PST PASSED contact is opened
- The DO PST FAILED contact is closed
- A new graph is stored (the Status is "Failed")

If the SOV A – SOV B TEST is successfully executed:

- "PST St." assumes the value "Passed"
- "M. PST Date" and "M. PST Time" assume the current date and time values
- PSA Alarm is cleared
- PSB Alarm is cleared
- The DO PST PASSED contact is closed
- The DO PST FAILED contact is opened
- A new graph is stored (the Status is "Passed")

5.2 Detailed Description

In this section are described the IMVS2000v2 general features and the functionalities of each input, output and interface of the IMVS2000v2.

Refer to 4.3 and to 9.1 for the pinout and electrical limits of the IMVS2000v2.

5.2.1 Configuration-Managing Interfaces

The IMVS2000v2 provides the following Configuration-Managing Interfaces:

- Local Operator Interface (Keypad-Display)
- RS232 Port
- Bluetooth Port
- HART (see [2] for details)
- MODBUS (see [3] for details)

5.2.1.1 Local Keypad and Display

The IMVS2000v2 is fitted with a graphic 128x64 OLED display and 3 push-buttons that allows setting the configuration parameters or to visualize the working data.

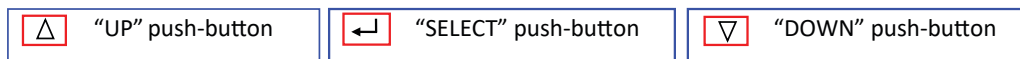

Two push-buttons "DOWN", "UP" are used to move into the menu and changing the value of the parameters, while the third "ENTER" is used to enter the selected information and for moving between the sub-menus and for waking-up the IMVS2000v2.

The configuration operations are protected by password. The operator can access the "Setup Mode" menu and change the parameters, only after entering the appropriate password.

For additional details dealing with the Local Operator Interfaces see the "LOCAL OPERATOR INTERFACE" paragraph.

5.2.1.2 RS232 – Bluetooth Ports

The RS232 and Bluetooth Ports allow configuring and managing the IMVS2000v2 through the "Biffi-Assistant" software tool [1].

The Bluetooth port can be disabled (see 6 for details).

For additional details dealing with the RS232 and Bluetooth Ports see [1].

5.2.2 Digital Input

The IMVS2000v2 is provided with three configurable opto-isolated Digital Inputs:

- SOLENOID A CONTROL
- SOLENOID B CONTROL
- PST CONTROL

Each DI is isolated from the other ones and can work with the following voltages:

- 9.2 - 57.6 Vdc (24 -20% - 48 +20%)

The SOLENOID A CONTROL and the SOLENOID B CONTROL are used for managing the external Solenoid Valves and their status determines the Position Request (see Sections 5.2.2.1 and 5.2.2.2 for details).

The SOLENOID A CONTROL and SOLENOID B CONTROL can also be used for the SOVs TEST (see Section 5.2.2.1 for details).

The PST CONTROL allows launching a Manual PST or a “SOV A TEST” or a “SOV A – SOV B TEST” (see Section 5.2.2.1 for details).

5.2.2.1 Digital Inputs Table

The table below explains the working mode of the Digital Inputs. See 6 for details about the configuration parameters.

Table 2.

Name	Terminals #	Type	Description	Type of Command
SOLENOID A CONTROL (SOV A CTRL) (*)(**)	19-20	Digital Input	<p>It is used for controlling the RELAY A contact that is used for managing the SOV A connected to the terminals 11-10-9 (COMMON-NO-NC).</p> <p>If SOV A CTRL = active and “Act. Mode” = “Double” or SOV A CTRL = not active and “Act. Mode” ≠ “Double” => Terminals 11-10: power supply applied on terminals 6-5 Terminals 11-9: 0 Volts</p> <p>If SOV A CTRL = not active and “Act. Mode” = “Double” or SOV A CTRL = active and “Act. Mode” ≠ “Double” => Terminals 11-10: 0 Volts Terminals 11-9: power supply applied on terminals 6-5</p> <p>This DI is used to define the “Position Request” (see the “Position Request Table”). The command, associated to this DI, is considered active when a correct voltage is applied on its terminals.</p>	Push to run
SOLENOID B CONTROL (SOV B CTRL) (*)(**)	21-22	Digital Input	<p>It is used for controlling the RELAY B contact that is used for managing the SOV B connected to the terminals 18-17-16 (COMMON-NO-NC) or for performing the SOV TEST on the SOV B.</p> <p>If “Act. Mode” ≠ “Double” and “SOV Qty” = “Simplex” and “PST Ser. SOVs” = “One”, this input is not read and it does not affect the control of the RELAY B.</p> <p>If “Act. Mode” ≠ “Double” and “SOV Qty” = “Simplex” and “PST Ser. SOVs” = “Both”, this input is used for launching the SOV TEST of the SOV B. The change from not active to active start the SOV Test.</p> <p>Otherwise the DI is used to control RL B to define the Position Request see the “Position Request Table” for details.</p> <p>If SOV B CTRL = active and “Act. Mode” = “Double” or SOV B CTRL = not active and “Act. Mode” ≠ “Double” => Terminals 18-17: power supply applied on terminals 13-12 Terminals 18-16: 0 Volts</p> <p>If SOV B CTRL = not active and “Act. Mode” = “Double” or SOV B CTRL = active and “Act. Mode” ≠ “Double” => Terminals 18-17: 0 Volts Terminals 18-16: power supply applied on terminals 13-12</p> <p>The command, associated to this DI, is considered active when a correct voltage is applied on its terminals.</p>	Push to run / Change of status (****)

Name	Terminals #	Type	Description	Type of Command
PST CONTROL (*)(***)	23-24	Digital Input	When activated a "Manual PST"/"SOV Test" command is performed. It's usually used for launching a Manual PST Command. If "PST En." = "No," "PST Pos. %" = 0.0%, "PST Pres. %" = 0%, and "PST Time %" = 0%, it's used for starting the SOV Test: <ul style="list-style-type: none"> If "Act. Mode" = "Single" or "Double-S," "PST Ser. SOVs" = "One" and "Sov Qty" = "Simplex," it's used for launching the SOV A Test. If "Act. Mode" = "Single" or "Double-S," "PST Ser. SOVs" = "Both" and "Sov Qty" = "Series," it's used for launching the SOV A – SOV B Test. See sections 5.1.9.3 and 5.1.9.4 for details. This command is activated on the first valid signal commutation (from "Low" to "High" of at least 1 second) and it is not repeated till a new valid signal commutation.	Pulse Control

- (*) It is automatically "ignored" during the execution of the following commands: Calibration, Baseline Signature, Maintenance Signature, Baseline PST and Manual PST.
- (**) If "Act. Mode" = "Double" if the SOV A CMD is active the SOV B CMD is automatically "ignored."
- (***) This command can be performed only if the Manual PST command is available (see 6 for details).
- (****) The change of status (from not active to active) is used when the DI is associated to the SOV TEST command.

5.2.2.2 Position Request Table

The following table shows how the Digital Inputs, according to different settings, determines the Position Request. See Section 6 for details about the configuration parameters.

Table 3.

Position Request Table – Digital Inputs					
"Act. Mode"	"Fail Action"	"SOVs Qty"	SOV A CTRL	SOV B CTRL	"Position Request" (*)
Single or Double-S	CL	Simplex	Active	-	100%
Single or Double-S	CL	Simplex	Not Active	-	0%
Single or Double-S	CL	Series	Active	Active	100%
Single or Double-S	CL	Series	Not Active	Active	0%
Single or Double-S	CL	Series	Active	Not Active	0%
Single or Double-S	CL	Series	Not Active	Not Active	0%
Single or Double-S	CL	Parallel	Active	Active	100%
Single or Double-S	CL	Parallel	Not Active	Active	100%
Single or Double-S	CL	Parallel	Active	Not Active	100%
Single or Double-S	CL	Parallel	Not Active	Not Active	0%
Single or Double-S	OP	Simplex	Active	-	0%
Single or Double-S	OP	Simplex	Not Active	-	100%

Position Request Table – Digital Inputs					
“Act. Mode”	“Fail Action”	“SOVs Qty”	SOV A CTRL	SOV B CTRL	“Position Request” (*)
Single or Double-S	OP	Series	Active	Active	0%
Single or Double-S	OP	Series	Not Active	Active	100%
Single or Double-S	OP	Series	Active	Not Active	100%
Single or Double-S	OP	Series	Not Active	Not Active	100%

Single or Double-S	OP	Parallel	Active	Active	0%
Single or Double-S	OP	Parallel	Not Active	Active	0%
Single or Double-S	OP	Parallel	Active	Not Active	0%
Single or Double-S	OP	Parallel	Not Active	Not Active	100%

Double	-	-	Active	Not Active	100%
Double	-	-	Not Active	Active	0%
Double	-	-	Not Active	Not Active	Last “Position Request”
Double	-	-	Active	Active	100%

5.2.3 Digital Output

The IMVS2000v2 is provided with 6 Digital Outputs (DO).

- OPEN
- CLOSED
- COMMON FAILURE ALARM
- PST IN PROGRESS
- PST PASSED
- PST FAILED

Each DO is isolated from the other ones and can work with the following voltages:

- Up to 57.6 Vdc – 0.5 A

They are SPST solid state dry contacts. When the IMVS2000v2 is not power supplied the DOs are all open contacts.

The OPEN, CLOSED and COMMON FAILURE ALARM digital outputs can be configured to work as normally open or normally closed contacts (see Section 5.2.3.1 for details).

5.2.3.1 Digital Outputs Table

See Section 6 for details about the configuration parameters.

Table 4.

Name	Terminals #	Type	Description (*)
OPEN	25-26	Digital Output	It is a solid state dry contact. If "Op. Cl. Mode" = "NO" (default setting): The contact is closed when the Fully Open Position is reached (according to the set "Open Position Hysteresis.") If "Op. Cl. Mode" = "NC": The contact is open when the Fully Open Position is reached (according to the set "Open Position Hysteresis.")
CLOSED	27-28	Digital Output	It is a solid state dry contact. If "Op. Cl. Mode" = "NO" (default setting): The contact is closed when the Fully Closed Position is reached (according to the set "Closed Position Hysteresis.") If "Op. Cl. Mode" = "NC": The contact is open when the Fully Closed Position is reached (according to the set "Closed Position Hysteresis.")
COMMON FAILURE ALARM	29-30	Digital Output	It is a solid state dry contact. If "Co. Fail Alr mode" = "NO" The contact is closed when "CFA St." = "Active". If "Co. Fail Alr mode" = "NC" The contact is open when "CFA St." = "Active". See 6 for details.
PST IN PROGRESS	31-32	Digital Output	It is a solid state dry contact that is closed during the PST execution (both Baseline PST and Manual PST) and the SOV TEST.
PST PASSED	33-34	Digital Output	It is a solid state dry contact that depends on the value of "PST Status": "PST Status" = "Passed" => contact closed "PST Status" = "Failed", "Not Done", "Conf. Err" => contact open "PST Status" = "Progress" => contact closed. (*) It is updated at the end of each PST or SOV Test. See 6 for details.
PST FAILED	35-36	Digital Output	It is a solid state dry contact that depends on the value of "PST Status": "PST Status" = "Passed" => contact open "PST Status" = "Failed", "Conf. Err" => contact closed "PST Status" = "Not Done" => contact open. "PST Status" = "Progress" => contact closed (*) It is updated at the end of each PST or SOV Test. See 6 for details.

Notes:

(*) During the SOV TEST, the "PST Status" = "Progress" but this contact remains at its present status without changing.

5.2.4 SIS Signals - SOV Outputs

Refer to the paragraph 9 for seeing the typical wiring diagrams of the IMVS2000v2.

The IMVS2000v2 is provided with two independent (isolated) circuits for controlling up to two external Solenoid Valves (SOVA and SOVB).

Each circuit has its own dedicated power supply (SIS A and SIS B) that through a relay is used to control the SOVA and SOVB (see 9 for details).

Both SIS A and SIS B power supply are continuously monitored and dedicated alarms can be generated (see Section 5.2.7 for details).

If the SIS A signal is not applied the IMVS2000v2 cannot energize the SOVA; when the SIS A is removed the SOVA is "automatically" de-energized.

If the SIS B signal is not applied the IMVS2000v2 cannot energize the SOVB; when the SIS B is removed the SOVB is "automatically" de-energized.

5.2.5 Position Sensor

The IMVS2000v2 is provided with an internal contactless position sensor. The position can be read on the shaft that is connected to the actuator.

The accuracy of the Position Sensor is 0.2%.

5.2.6 Pressure Sensors

The IMVS2000v2 can be equipped with up to three internal pressure sensors (see Section 10.5 for details):

- Pressure Sensor S1 – Pressure 1
- Pressure Sensor S2 – Pressure 2
- Pressure Sensor S3 – Process Pressure

The Pressure Sensor S1 and S2 are used for measuring the pressure of the actuator and the Pressure Sensor S3 for monitoring an external pressure (i.e. pipeline pressure).

Each pressure sensor can be selected with the following pressure sizes (see Section 14 for details):

- 10 bar (145 psi)
- 100 bar (1450 psi)
- 200 bar (2900 psi)
- 400 bar (5800 psi)

The value of the Pressure is shown and stored (event data memory) the following way depending on the size of the pressure sensor:

- 10 bar 2 fractional digits
- 100, 200 bar 1 fractional digit
- 145 psi 1 fractional digit
- 1450, 2900, 5800 psi 0 fractional digit

The accuracy of each pressure sensor is 5%.

5.2.7 Alarms

The IMVS2000v2 has five main groups:

- PST Alarms
- FST Alarms
- General Diagnostic Alarms
- Auto-diagnostic Alarms
- CAL alarm

The PST Alarms deal with the results of the PST. They are “acyclic” alarm that can be activated at the end of a PST execution.

They are de-activated by a power-on reset or by the “Reset Alarms” command.

The FST Alarms deal with the results of the FST. They are “acyclic” alarm that can be activated at the end of a FST execution.

They are de-activated by a power-on reset or by the “Reset Alarms” command.

The General Diagnostic Alarms monitors the valve/actuator position, pressures, the status of the SIS A and SIS B power supplies and the PST and FST counters.

They are cyclically checked and they are only temporarily de-activated by a power-on reset or by the “Reset Alarms” command.

The Auto-diagnostic Alarms monitor the status of the internal position and pressure sensors.

They are cyclically checked and they are only temporarily de-activated by a power-on reset or by the “Reset Alarms” command.

All the alarms, excepting the CAL, POS, PSNM, CLNM and OPNM alarms, can be enabled/disabled as follows:

- Set as “No” – the alarm is disabled
- Set as “ALR” – the alarm is enabled and not associated to the Common Failure Alarm Status.
- Set as “CFA” – the alarm is enabled and associated to the Common Failure Alarm Status.

The CAL alarm is always associated to the Common Failure Alarm Status and cannot be disabled.

The POS alarm cannot be set to "No."

The PST Alarms, when enabled, are always associated to the PST Status.

The cyclically checked alarms set as "No" are disabled at the next check instant.

If the PST Alarms and the FST Alarms are disabled, the setting has effect on the further PST and FST.

See Section 6 and Section 8 for details about alarms.

5.2.8 Graphs – Sampling Time – Memory

The IMVS2000v2 can store as graphs the following events:

- Opening FST
- Closing FST
- PST
- SOV Test

Each graph is composed by 351(#) samples for the following data:

- Time (seconds)
- Pressure 1 (bar or psi) – pressure sensor S1 (*)
- Pressure 2 (bar or psi) – pressure sensor S2 (**)
- Process pressure (bar or psi) – pressure sensor S3 (***)
- Position (%)
- |Pr. 1 – Pr. 2| - absolute value of the difference between Pressure 1 and Pressure 2 (**).

(#): the "Digital Input FST Graphs" and "External Source FST Graphs" can have less than 351 samples (see Sections 5.2.8.1 and 5.2.8.2 for details).

(*): if the pressure sensor 1 is enabled

(**): if the pressure sensor 2 is present and enabled.

(***): if the process pressure sensor is present and enabled.

The samples period is a multiple of 5ms.

The time length of each graph is a multiple of 1.75 seconds.

The time length of each graph is automatically calculated by the IMVS2000v2.

The time length of the Opening FST is determined by the parameter Opening Maximum Time that is automatically set equal to the Opening Calculated Time (see Section 6 for details).

The time length of the Closing FST is determined by the parameter Closing Maximum Time that is automatically set equal to the Closing Calculated Time (see Section 6 for details).

The time length of the PST is determined by the parameter PST Maximum Time that is automatically set equal to the PST Calculated Time (see Section 6 for details).

The time length of the SOV Test is automatically calculated by the IMVS2000v2 during the Baseline Signature and it can't be modified.

If the Opening Maximum Time or the Closing Maximum Time or the PST Maximum Time are manually set (only for expert users), the value is automatically rounded up to the nearest multiple of 1.75 seconds.

The IMVS2000v2 can store up to:

- 50 FST Graphs (2 are dedicated to the Baseline Signature)
- 50 PST or SOV TEST Graphs (1 is dedicated to the Baseline PST or Baseline SOV Test)

The graphs are stored in a non-volatile memory.

5.2.8.1 Digital Input FST Graphs

The IMVS2000v2 stores the graphs of the Opening FST and Closing FST generated through the Digital Inputs (SOV A CONTROL and SOV B CONTROL).

If the parameter "M. FST Alr En" (see 6 for details) is set to "Yes" the data of the Digital Input FSTs are compared with the Baseline ones for diagnostic.

If the parameter "M. FST Alr En." is set to "No" the Digital Input FST is only stored as a graph and not used for diagnostic (Travel Time, Break Time and Break Pressure are not measured and stored).

For using Digital Input FSTs for diagnostic and obtaining consistent results it is recommended to:

- to open and close the actuator when pressures and position are stable
- for the Opening FST wait for the Opening Maximum Time before Closing (*)
- for the Closing FST wait for the Closing Maximum Time before Opening (*)

(*): the graph could have less than 351 samples.

The Digital Input FST Graphs can be stored only if Baseline Signature is already successfully performed.

5.2.8.2 External Source FST Graphs

The IMVS2000v2 can store the graphs of the FST generated by external sources (i.e. SOVs not controlled by the IMVS2000v2).

The FST is memorized only if the position changes at least 1% in a time equal to the Opening Break Time (for the Opening FST) or the Closing Break Time (for the closing FST).

If the position is greater than 50% the IMVS2000v2 can detect Closing FST generated by External Sources otherwise it can detect Opening FST.

The External Source FST is only stored as graph and never compared with the Baseline Signature (no alarms can be generated). Time, Break Time and Break Pressure are not measured and stored.

The External Source FST Graphs can be stored only if Baseline Signature is already successfully performed.

5.2.8.3 External Source PST Graphs

When the PST Graph stored is a SOV Test, the source is saved as "External Contro."

The Baseline SOV Test is always placed at position 1.

Section 6: Configuration Parameters

This section lists and describes the configuration parameters of the IMVS2000v2. For details about the mapping of the parameters on the Local Operator Interface, see 7. For details about the mapping of the parameters on the “Biffi-Assistant” SW tool (RS232 and Bluetooth), see [1]. For details about the mapping of the parameters on the Bus Interfaces see the relevant manuals.

Table 5.

PARAMETERS OF THE “VIEW/SETUP MODE” MENU					
PARAMETER NAME	DESCRIPTION	RANGE	DEFAULT VALUE	R/W (1)	AVAILABLE ON (2) (3)
Dev. Mfr (Device Manufacturer)		Biffi	Biffi	R	Local, Serial, Bus
Dev. Name (Device Name)		IMVS2000v2	IMVS2000v2	R	Local, Serial, Bus
Dev. Tag (Device Tag Name)	It is the named used the Bluetooth connection. The Bluetooth name is created as follows: “BIFI”+16 characters+ “-IMVS.”	16 characters	All “0”	R/W	Local, Serial, Bus
Dev. S.N. (Device Serial Number)		20 characters	All “0”	R/W	Local, Serial, Bus
Dev. Date (Device Date of Manufacturing)		01-01-2014 31-12-2099	01-01-2014	R/W	Local, Serial, Bus
SW L. Card. (SW Logic Card revision)		xx.xx.xx		R	Local, Serial, Bus
SW D. Card. (SW Display Card revision)		xx.xx.xx		R	Local, Serial, Bus
Actuator Parameters					
Act. Mfr (Actuator Manufacturer)		12 characters	All “ “	R/W	Local, Serial, Bus
Act. Model (Actuator Model)		20 characters	All “ “	R/W	Local, Serial, Bus
Act. Tag (Actuator Tag Name)		20 characters	All “ “	R/W	Local, Serial, Bus
Act. S.N. (Actuator Serial Number)		20 characters	All “ “	R/W	Local, Serial, Bus
Act. Pr. Size (Actuator Pressure Size)		10 characters	All “ “	R/W	Local, Serial, Bus
Act. Date (Actuator Date of Manufacturing)		01-01-2014 31-12-2099	01-01-2014	R/W	Local, Serial, Bus
Valve Parameters					
Valve Mfr (Valve Manufacturer)		12 characters	All “ “	R/W	Local, Serial, Bus
Valve Model		20 characters	All “ “	R/W	Local, Serial, Bus
Valve Tag (Valve Tag Name)		20 characters	All “ “	R/W	Local, Serial, Bus
Valve S.N. (Valve Serial Number)		20 characters	All “ “	R/W	Local, Serial, Bus
Valve Date (Valve Date of Manufacturing)		01-01-2014 31-12-2099	01-01-2014	R/W	Local, Serial, Bus
Act. Mode (Acting Mode)	“Single” must be set in case of: <ul style="list-style-type: none"> • Single Acting actuator with single SOV. • Single Acting actuator with 2 SOVs in series or in parallel. “Double” must be set in case of: <ul style="list-style-type: none"> • Double Acting actuator with dual SOVs. “Double-S” must be set in case of: <ul style="list-style-type: none"> • Double Acting actuator with single SOV. • Double Acting actuator with 2 SOVs in series or in parallel. See 6.2 for details. If change it can generate the CAL alarm (see 8).	Single, Double, Double-S	Single	R/W	Local, Serial, Bus

PARAMETERS OF THE "VIEW/SETUP MODE" MENU					
PARAMETER NAME	DESCRIPTION	RANGE	DEFAULT VALUE	R/W (1)	AVAILABLE ON (2) (3)
activOpen. Rot. (Opening Rotation)	It defines the sense of rotation of the Opening Stroke. "CW" = Clock Wise "CCW" = Counter Clock Wise If change it can generate the CAL alarm (see Section 8).	CW, CCW	CCW	R/W	Local, Serial, Bus
Fail Action	It defines the "direction" of the Fail Action. "CL" = Fail To Close "OP" = Fail To Open If change it can generate the CAL alarm (see Section 8).	CL, OP	OP	R/W	Local, Serial, Bus
SOVs Qty (SOVs Quantity)	It is applicable only if "Act. Mode" is "Single" or "Double-S". It deals with the number of SOVs managed by the IMVS2000v2. "Simplex" = single SOV or 2 SOVs in series (it depends on the value of "PST Ser. SOVs"). "Series" = 2 SOVs in series "Parallel" = 2 SOVs in parallel See Section 6.2 for details. If change it can generate the CAL alarm (see Section 8).	Simplex, Series, Parallel	Simplex	R/W	Local, Serial, Bus
Pr. S. 1-2 (Pressure Sensor 1-2)	It is pressure range of the pressure sensors #1 and #2. "None" = Pressure sensors 1 and 2 not present. The pressure measurement unit (bar or psi) is determined by the setting of the "Pres. M.U." parameter.	None, 10, 20, 50, 100, 200, 400 bar (None, 145, 290, 725, 1450, 2900, 5800 psi).	100 bar (1450psi)	R	Local, Serial, Bus
Proc. S. (Process Sensor)	It is pressure range of the process pressure sensor. "None" = Process pressure sensor not present. It is pressure range of the process pressure sensor. The pressure measurement unit (bar or psi) is determined by the setting of the "Pres. M.U." parameter.	None, 10, 20, 50, 100, 200, 400 bar (None, 145, 290, 725, 1450, 2900, 5800 psi).	None	R	Local, Serial, Bus
Set Pr. 1-2 (Set Pressure 1-2)	This command is used to set the pressure range of the pressure sensors #1 and #2. It sets the value of the parameter Pr. S. 1-2).	None, 10, 20, 50, 100, 200, 400 bar	100 bar (1450 psi)	R/W	Local, Serial.
Set Proc. (Set Process Pressure)	This command is used to set the pressure range of the process pressure sensor. It set the value of the parameter Proc. S.	None, 10, 20, 50, 100, 200, 400 bar	None	R/W	Local, Serial.
RL A Cmd. (Relay A Command)	If set as "Active," the DI "SOLENOID A CONTROL" is consider as active despite of its real status. If set as "Not Active", the status of the DI "SOLENOID A CONTROL" is determined by its status only. Changing this parameter could cause the Actuator/ Valve stroking. See Section 5.2.2 for details.	Not Active, Active	Not Active	R/W	Local, Serial, Bus
RL B Cmd. (Relay B Command)	If set as "Active", the DI "SOLENOID B CONTROL" is consider as active despite of its real status. If set as "Not Active.", the status of the DI "SOLENOID B CONTROL" is determined by its status only. If "Act. Mode" ≠ "Double" and "SOV Qty" = "Simplex" and "PST Ser. SOVs" = "Both" this input can be used for launching the SOV TEST of the SOV B. See Section 5.2.2 for details Changing this parameter could cause the Actuator/ Valve stroking. See Section 5.2.2 for details.	Not Active, Active	Not Active	R/W	Local, Serial, Bus

PARAMETERS OF THE "VIEW/SETUP MODE" MENU					
PARAMETER NAME	DESCRIPTION	RANGE	DEFAULT VALUE	R/W (1)	AVAILABLE ON (2) (3)
Sign. En. (Signatures Enabled)	If it is set as "Yes" it is possible to perform commands "Baseline Signature" and "Maintenance Signature" otherwise they do not work.	Yes, No	Yes	R/W	Local, Serial, Bus
Op. Pos. % (Open Position Hysteresis)	It defines the tolerance for considering the actuator/valve as open (it can be "masked" by the Closed Position Hysteresis). Its value affects the "OPEN" Digital Output (see DOs for details) and the activation of the OPOS alarm (see Section 8 for details). It affects the validity of the PST (PSSR Alarm) and FST starting points and if set to a value different to default one it could influence the PST and FST results.	0 – 90.0 %	3%	R/W	Local, Serial, Bus
Cl. Pos. % (Closed Position Hysteresis)	It defines the tolerance for considering the actuator/valve as closed. Its value affects the "CLOSED" Digital Output (see Section 5.2.3 for details) and the activation of the CPOS alarm (see Section 8 for details). It affects the validity of the PST (PSSR Alarm) and FST starting points and if set to a value different to default one it could influence the PST and FST results.	0 – 90.0 %	3%	R/W	Local, Serial, Bus
Op. Time % (Opening Time Hysteresis)	It defines the tolerance for the generation of the following alarms: SOBT, FOBT, SOTT and FOTT. See Section 8 for details. This parameter affects the "duration" of the Opening FST time window. It is suggested to perform a new "Baseline Signature" after changing this parameter to better compare the next Signatures and FSTs.	0 -200%	20 %	R/W	Local, Serial, Bus
Cl. Time % (Closing Time Hysteresis)	It defines the tolerance for the generation of the following alarms: SCBT, FCBT, SCTT and FCTT. See Section 8 for details. This parameter affects the "duration" of the Closing FST time window. It is suggested to perform a new "Baseline Signature" after changing this parameter to better compare the next Signatures and FSTs.	0 -200 %	20 %	R/W	Local, Serial, Bus
FST. Pr. % (FST Pressure Hysteresis)	It defines the tolerance for the generation of the following alarms: OHBP, OLBP, CHBP and CLB. See Section 8 for details.	0 -100 %	20 %	R/W	Local, Serial, Bus
H. Pr. Lim. (High Pressure Limit)	It is applicable only if "Act. Mode" ≠ "Double". It defines the threshold for the generation HSP alarm. See Section 8 for details. The pressure measurement unit (bar or psi) is determined by the setting of the "Pres. M.U." parameter.	0 – 400 bar (0 – 5800 psi)	400 bar (5800 psi)	R/W	Local, Serial, Bus
L. Pr. Lim. (Low Pressure Limit)	It is applicable only if "Act. Mode" ≠ "Double". It defines the threshold for the generation LSP alarm. See Section 8 for details. The pressure measurement unit (bar or psi) is determined by the setting of the "Pres. M.U." parameter.	0 – 400 bar (0 – 5800 psi)	0 bar (0 psi)	R/W	Local, Serial, Bus
H. Proc. L. (High Process Pressure Limit)	It is applicable only if the Process Pressure Sensor is present ("Proc. S" is not set to "None"). It defines the threshold for the generation HPP alarm. See Section 8 for details. The pressure measurement unit (bar or psi) is determined by the setting of the "Pres. M.U." parameter.	0 – 400 bar (0 – 5800 psi)	400 bar (5800 psi)	R/W	Local, Serial, Bus

PARAMETERS OF THE "VIEW/SETUP MODE" MENU					
PARAMETER NAME	DESCRIPTION	RANGE	DEFAULT VALUE	R/W (1)	AVAILABLE ON (2) (3)
L. Proc L. (Low Process Pressure Limit)	It is applicable only if the Process Pressure Sensor is present ("Proc. S" is not set to "None"). It defines the threshold for the generation LPP alarm. See Section 8 for details. The pressure measurement unit (bar or psi) is determined by the setting of the "Pres. M.U." parameter.	0 – 400 bar (0 – 5800 psi)	0 bar (0 psi)	R/W	Local, Serial, Bus
FST. Cyc. L. (FST Cycle Limit)	It defines the threshold for the generation FSCL alarm. See Section 8 for details.	1 -100000	10000	R/W	Local, Serial, Bus
FST Cyc. C. (FST Cycle Count)	It is a counter of the FST. It is increased by 1 each time that an Opening or Closing FST is performed. It can be reset.	0 - 100000	0	R/W	Local, Serial, Bus
FST. Ab. C. (FST Absolute Count)	It is a counter of the FST. It is increased by 1 each time that an Opening or Closing FST is performed. It cannot be reset.	0 - 1000000	0	R	Local, Serial, Bus
PST En. (PST Enabled)	If it is set as "Yes" it is possible to perform the PST otherwise the commands "Baseline PST" and "Manual PST" do not work. If it is set as "No", "PST Pos. %" = 0.0%, "PST Pr. %" = 0% and "PST Time %" = 0%, it's possible to perform the SOV Test. See Section 5.1.6 for details.	Yes, No	Yes	R/W	Local, Serial, Bus
PST Set. (PST Setpoint)	It defines the position to be reached during the PST. It must be considered that 100% corresponds to the fully open and 0% to the fully closed position. This parameter affects the "duration" of the PST time window. It is recommended to perform a new "Baseline PST" after changing this parameter to better compare the next PSTs.	5.0 – 95.0 %	75.0 %	R/W	Local, Serial, Bus
PST Pos. % (PST Position Hysteresis)	It defines the threshold for the PSSP alarm. See Section 8 for details. If it is set equal to 0.0%, "PST En." = "No", "PST Pr. %" = 0% and "PST Time %" = 0%, it's possible to perform the SOV Test. See Section 5.1.6 for details.	0.0 – 100.0 %	20.0 %	R/W	Local, Serial, Bus
PST Pr. % (PST Pressure Hysteresis)	It defines the tolerance for the generation of the following alarms: PSLB and PSHB. See 8 for details. If it is set equal to 0%, "PST En." = "No", "PST Pos. %" = 0.0% and "PST Time %" = 0%, it's possible to perform the SOV Test. See Section 5.1.6 for details.	0 -100 %	20 %	R/W	Local, Serial, Bus
PST Time % (PST Time Hysteresis)	It defines the tolerance for the generation of the following alarms: PSBB, PSFB, PSST and PSFT. See Section 8 for details. This parameter affects the "duration" of the PST time window. It is suggested to perform a new "Baseline PST" after changing this parameter to better compare the next PSTs. If it is set equal to 0%, "PST En." = "No", "PST Pos. %" = 0.0% and "PST Pr. %" = 0%, it's possible to perform the SOV Test. See Section 5.1.6 for details.	0 – 200%	20 %	R/W	Local, Serial, Bus

PARAMETERS OF THE "VIEW/SETUP MODE" MENU					
PARAMETER NAME	DESCRIPTION	RANGE	DEFAULT VALUE	R/W (1)	AVAILABLE ON (2) (3)
PST Ser. SOVs (PST Series SOVs)	It is applicable only if "Act. Mode" ≠ "Double" and "Pr. S. 1-2" ≠ "None" and "SOVs Qty" ≠ "Parallel." It determines the way to perform the PST for 2 SOVs in series or to enable the SOVs TEST. See Sections 5.1.9 and 5.1.6 for details.	One, Both	Both	R/W	Local, Serial, Bus
PST. Cyc. L. (PST Cycle Limit)	It defines the threshold for the generation PSCL alarm. See Section 8 for details.	1 -100000	10000	R/W	Local, Serial, Bus
PST Cyc. C. (PST Cycle Count)	It is a counter of the PST. It is increased by 1 each time that a PST is performed. It can be reset.	0-100000	0	R/W	Local, Serial, Bus
PST Ab. C. (PST Absolute Count)	It is a counter of the PST. It is increased by 1 each time that a PST is performed. It cannot be reset.	0-1000000	0	R	Local, Serial, Bus
A. PST En. (Automatic PST Enable)	It enables the Automatic PST. The Automatic PST is executed according to the settings of the parameters "Auto. PST Period" and "Auto. PST Time." The Automatic PST starts its periodically execution only if a "Baseline PST" is already performed.	Yes, No	No	R/W	Local, Serial, Bus
A.PST Per. (Automatic PST Period)	It defines how often the Automatic PST will automatically run.	1 - 365 days	90 days	R/W	Local, Serial, Bus
A. PST Date (Automatic PST Date)	It defines the date when the Automatic PST will start.	01-01-2014 31-12-2099	01-01-2014	R/W	Local, Serial, Bus
A.PST Time (Automatic PST Time)	It defines the hour of the day when the Automatic PST will be run.	00.00 - 23.59	08.00	R/W	Local, Serial, Bus
Calibration Cmd	It is the command for performing the device Calibration. See Section 5.1.1 for details. The "Calibration" deletes all the stored Baseline and Maintenance FSTs and all the stored Baseline and Manual PSTs.	Start		C	Local, Serial, Bus
Cal. Date (Calibration Date)	It is the date of the last performed Calibration.	01-01-2014 31-12-2099	01-01-2014	R	Local, Serial, Bus
Cal. Time (Calibration Time)	It is the time of the last performed Calibration.	0.00 - 23.59	08.00	R	Local, Serial, Bus
Cal. Status (Calibration Status)	It is the status of the last performed Calibration. "Not Done": no Calibration is performed yet. "Progress": during the execution of the Calibration. "Failed": some errors occur during the last Calibration. "Passed": Calibration successfully performed.	Passed, Failed, Progress, Not Done.	Not Done	R	Local, Serial, Bus
Cal. Enabled (Calibration Enabled)	If it is set as "Yes" it is possible to perform command "Calibration" otherwise it does not work.	Yes, No	Yes	R/W	Local, Serial, Bus
Base. Sig. Cmd (Baseline Signature Command)	It is the command for performing the "Baseline Signature." See Section 5.1.2 for details. This command can be performed only if a Calibration is already successfully performed ("Cal. Status" = "Passed") and if the CAL alarm is not active (see Section 8 for details). The "Baseline Signature" deletes all the stored Maintenance FSTs and Baseline and Manual PSTs and SOVs Test.	Start		C	Local, Serial, Bus
Mnt. Sig. Cmd (Maintenance Signature Command)	It is the command for performing the "Maintenance Signature." See Section 5.1.2 for details. This command can be performed only if a Baseline Signature is already successfully performed ("Base S. Status" = "Passed") and if the CAL alarm is not active (see Section 8 for details).	Start		C	Local, Serial, Bus
Op. Cal. T. (Opening Calculated Time)	It is the calculated time for the Opening FST graphs. See Section 5.2.8 for details.	1.7-2000 sec		R	Local, Serial, Bus

PARAMETERS OF THE "VIEW/SETUP MODE" MENU					
PARAMETER NAME	DESCRIPTION	RANGE	DEFAULT VALUE	R/W (1)	AVAILABLE ON (2) (3)
Op. Max. T. (Opening Maximum Time)	It determines the "duration" of the graph of the opening FST. It is set by default at the same value of "Op. Cal. T." any time that a "Calibration" is performed and that the "Op. Time %" parameter is set. See Section 5.2.8 for details. This parameter must be modified only if strictly necessary by expert users. It can affect the operating mode of the device.	1.7–2000 sec	Op. Cal. Time	R/W	Local, Serial, Bus
Cl. Cal. T. (Closing Calculated Time)	It is the calculated time for the Closing FST graphs. See Section 5.2.8 for details.	1.7–2000 sec		R	Local, Serial, Bus
Cl. Max. T. (Closing Maximum Time)	It determines the "duration" of the graph of the closing FST. It is set by default at the same value of "Cl. Cal. Time" any time that a "Calibration" is performed and that the "Cl. Time %" parameter is set. See Section 5.2.8 for details. This parameter must be modified only if strictly necessary by expert users. It can affect the operating mode of the device.	1.7–2000 sec	Cl. Cal. Time	R/W	Local, Serial, Bus
Base. S. St. (Baseline Signature Status)	It is the status of the last Baseline Signature. "Not Done": no Baseline Signature is performed yet. "Progress": during the execution of a Baseline Signature. "Failed": some errors occur during the last Baseline Signature. "Passed": Baseline Signature successfully performed. "Conf_Err": the command is not performed due to wrong configuration or "Pos. Req" not aligned with "Position" or if the command is not available ("Signatures En." or "Cal. Status") or "Op. Max time" = 0 or "Cl. Max Time" = 0, CAL or POS alarms active, etc. "Failed" is squelched by "Conf. Err." It is set to "Not Done" after every Calibration.	Not Done, Passed, Failed, Progress Conf_Err	Not Done	R	Local, Serial, Bus
B.S. Date (Baseline Signature Time)	It is the date of the last performed Baseline Signature. It is set to "01-01-2014" after every Calibration.	01-01-2014 31-12-2099	01-01-2014	R	Local, Serial, Bus
B.S. Time (Baseline Signature Date)	It is the time of the last performed Baseline Signature. It is set to "08.00" after every Calibration.	00.00 – 23.59	08.00	R	Local, Serial, Bus
Op. Status (Opening Status)	It is the status of the last opening FST. It is "Not Done" if no Opening FST is performed yet. It is "Failed" if at least one of the following alarms is generated during the last Opening FST: SOBT, FOBT, SOTT, FOTT, OHBP, OLBP, OPNM and OPCT. Otherwise it is "Passed." See Section 8 for details. It is set to "Not Done" after every Calibration or Baseline Sign.	Not Done, Passed, Failed.	Not Done	R	Local, Serial, Bus

PARAMETERS OF THE "VIEW/SETUP MODE" MENU					
PARAMETER NAME	DESCRIPTION	RANGE	DEFAULT VALUE	R/W (1)	AVAILABLE ON (2) (3)
Cl. Status (Closing Status)	<p>It is the status of the last closing FST. It is "Not Done" if no Closing FST is performed yet. It is "Failed" if at least one of the following alarms is generated during the execution of the last Closing FST: SCBT, FCBT, SCTT, FCTT, CHBP, CLBP, CLNM and CLCT. Otherwise it is "Passed." See 8 for details.</p> <p>It is set to "Not Done" after every Calibration or Baseline Sign.</p>	Not Done, Passed, Failed.	Not Done	R	Local, Serial, Bus
Mnt S. St. (Maintenance Signature Status)	<p>It is the status of the last Maintenance Signature. "Not Done": no Maintenance Signature is performed yet. "Progress": during the execution of a Maintenance Signature. "Failed": if at least one of the following alarms is generated during its last execution: SOBT, FOBT, SOTT, FOTT, OHBP, OLBP, SCBT, FCBT, SCTT, FCTT, CHBP, CLBP, CLCT, CLNM, OPNM and OPCT. "Conf_Err": the command is not performed due to wrong configuration or "Pos. Req" not aligned with "Position" or if the command is not available ("Signatures En." or "Base. S. Status"), or "Op. Max time" = 0 or "Cl. Max Time" = 0, CAL or POS alarms active, etc. Otherwise it is "Passed."</p> <p>"Failed" is squelched by "Conf. Err." See 8 for details.</p> <p>It is set to "Not Done" after every Calibration or Baseline Sign.</p>	Not Done, Passed, Failed, Progress, Conf_Err	Not Done	R	Local, Serial, Bus
M.S. Date (Maintenance Signature Time)	<p>It is the date of the last performed Maintenance Signature. It is set to "01-01-2014" after every Calibration or Baseline Sign.</p>	01-01-2014 31-12-2099	01-01-2014	R	Local, Serial, Bus
M.S. Date (Maintenance Signature Time)	<p>It is the time of the last performed Maintenance Signature. It is set to "08.00" after every Calibration or Baseline Sign.</p>	00.00 – 23.59	08.00	R	Local, Serial, Bus
FST Stored	<p>It indicates the number of the stored FSTs. It is set to "0" after every Calibration. It is set to "2" after every Baseline Signature successfully done.</p>	0-50	0	R	Local, Serial, Bus
FST ID	<p>It indicates the FST whose data are shown in the "FST Info."</p> <p>The FST ID 1 and 2 are dedicated to the FSTs of the Baseline Signature.</p> <p>The last FST (not one of the Baseline Signature) has the "FST ID" = 3 and the oldest FST has the "FST ID" = "FST Stored."</p>	1-50	0	R/W	Local, Serial, Bus

PARAMETERS OF THE "VIEW/SETUP MODE" MENU					
PARAMETER NAME	DESCRIPTION	RANGE	DEFAULT VALUE	R/W (1)	AVAILABLE ON (2) (3)
FST Info	<p>The FST Type, FST Source, FST Status, FST date and time, FST Break and Travel Times, FST Break Pressure of the selected FST ("FST ID") are shown. If "FST ID" > "FST Stored" than "all zeros" are shown. Using the Serial Interfaces, the "FST Info" is "included" into the graph of Event (see [1]).</p> <p>FST Type: "OP" (Opening FST) or "CL" (Closing FST).</p> <p>FST Source: "Base" (Baseline Sign.), "Maint" (Maintenance Sign.), "D.I." (Digital Input) or "Ext." (External Source).</p> <p>FST Status: "Not Done," "Passed," "Failed," "Conf. Err." See Section 5 for details.</p>	-	-	R	Local, Serial, Bus
B. Op. B. T. (Baseline Opening Break time)	It is the time measured during the Baseline Signature (Opening FST) that occurred for going from the Starting Closed position to the "Cl. Break Pos." See Section 5.1.8 for details.	0-1000.0 sec	0 sec	R	Local, Serial, Bus
M. Op. B. T. (Maintenance Opening Break Time)	<p>It is the time measured during the last required Opening FST that occurred for going from the Starting Closed position to the "Cl. Break. Pos." See Section 5.1.8 for details.</p> <p>It is not updated in case of External Source FST and Digital Input FST with "M. FST Alr En." = "No". See Section 5.2.8 for details.</p>	0-1000.0 sec	0 sec	R	Local, Serial, Bus
B. Op. T. T. (Baseline Opening Travel Time)	It is the time measured during the Baseline Signature (Opening FST) that occurred for going from the "Cl. Break Pos" to the 100% - "Op.Break Pos." See Section 5.1.8 for details.	0-1000.0 sec	0 sec	R	Local, Serial, Bus
M. Op. T. T. (Maintenance Opening Travel Time)	<p>It is the time measured during the last required Opening FST that occurred for going from the "Cl. Break Pos" to the 100% - "Op.Break Pos." See Section 5.1.8 for details.</p> <p>It is not updated in case of External Source FST and Digital Input FST with "M. FST Alr En." = "No". See Section 5.2.8 for details.</p>	0-1000.0 sec	0 sec	R	Local, Serial, Bus
B. Op. B. P. (Baseline Opening Break Pressure)	<p>It is the pressure measured during the Baseline Signature (Opening FST) when the position reaches "Cl.Break Pos." See Section 5.1.8 for details.</p> <p>If "Act. Mode" ≠ "Single", this pressure value is made by the absolute value of the difference between Pressure 1 and Pressure 2</p>	0-400 bar (0-5800 psi)	0 bar	R	Local, Serial, Bus
M. Op. B. P. (Maintenance Opening Break Pressure)	<p>It is the pressure measured during last required Opening FST when the position reaches "Cl. Break Pos." See Section 5.1.8 for details.</p> <p>If "Act. Mode" ≠ "Single", this pressure value is made by the absolute value of the difference between Pressure 1 and Pressure 2.</p> <p>It is not updated in case of External Source FST and Digital Input FST with "M. FST Alr En." = "No." See Section 5.2.8 for details.</p>	0-400 bar (0-5800 psi)	0 bar	R	Local, Serial, Bus

PARAMETERS OF THE "VIEW/SETUP MODE" MENU					
PARAMETER NAME	DESCRIPTION	RANGE	DEFAULT VALUE	R/W (1)	AVAILABLE ON (2) (3)
B. Cl. B. T. (Baseline Closing Break Time)	It is the time measured during the Baseline Signature (Closing FST) that occurred for going from the Starting Open position to the 100% - "Op. Break Pos." See Section 5.1.6 for details.	0-1000.0 sec	0 sec	R	Local, Serial, Bus
M. Cl. B. T. (Maintenance Closing Break Time)	It is the time measured during the last required Closing FST that occurred going from the Starting Open position to the 100% - "Op. Break Pos". See 5.1.6 for details. It is not updated in case of External Source FST and Digital Input FST with "M. FST Alr En." = "No." See Section 5.2.8 for details.	0-1000.0 sec	0 sec	R	Local, Serial, Bus
B. Cl. T. T. (Baseline Closing Travel Time)	It is the time measured during the Baseline Signature (Closing FST) that occurred for going from the 100% - "Op. Break Pos" to the "Cl. Break Pos." See Section 5.1.6 for details.	0-1000.0 sec	0 sec	R	Local, Serial, Bus
M. Cl. T. T. (Maintenance Closing Travel Time)	It is the time measured during the last required Closing FST that occurred for going from the 100% - "Op. Break Pos" to the "Cl. Break Pos.". See Section 5.1.6 for details. It is not updated in case of External Source FST and Digital Input FST with "M. FST Alr En." = "No.". See Section 5.2.8 for details.	0-1000.0 sec	0 sec	R	Local, Serial, Bus
B. Cl. B. P. (Baseline Closing Break Pressure)	It is the pressure measured during the Baseline Signature (Closing FST) when the position reaches 100% - "Op. Break Pos". See Section 5.1.6 for details. If "Act. Mode" ≠ "Single", this pressure value is made by the absolute value of the difference between Pressure 1 and 2.	0 – 400 bar (0 – 5800 psi)	0 bar	R	Local, Serial, Bus
M. Cl. B. P. (Maintenance Closing Break Pressure)	It is the pressure measured during last required (managed by the IMVS2000v2) Closing FST when the position reaches 100% - "Op. Break Pos". See Section 5.1.6 for details. If "Act. Mode" ≠ "Single", this pressure value is made by the absolute value of the difference between Pressure 1 and 2. It is not updated in case of External Source FST and Digital Input FST with "M. FST Alr En." = "No." See Section 5.2.8 for details.	0 – 400 bar (0 – 5800 psi)	0 bar	R	Local, Serial, Bus
Base. PST Cmd (Baseline PST Command)	<p>It is the command for performing the "Baseline PST" or "Baseline SOV Test."</p> <p>The "Baseline PST" can be performed only if a Baseline Signature is already successfully performed ("Base S. Status" = "Passed"), if "PST En." = "Yes" and if the CAL alarm is not active. See Section 5.1.5 for details.</p> <p>The "Baseline SOV Test" can be performed only if a "Baseline Signature is already successfully performed ("Base S. Status" = "Passed"), if "PST En." = "No", if "PST Pos %" = "0.0%", if "PST Pr. %" = 0% and if "PST Time %" = "0%". See Section 5.1.6 for details.</p> <p>The "Baseline PST" / "Baseline SOV Test" deletes all the previous PSTs / SOVs Tests stored.</p>	Start		C	Local, Serial, Bus

PARAMETERS OF THE "VIEW/SETUP MODE" MENU					
PARAMETER NAME	DESCRIPTION	RANGE	DEFAULT VALUE	R/W (1)	AVAILABLE ON (2) (3)
Manual PST Cmd (Manual PST Command)	It is the command for performing the "Manual PST"/"SOV Test." "Manual PST" can be performed only if a Baseline PST is already successfully performed ("Base. PST Status" = "Passed"), if "PST En." = "Yes" and if the CAL alarm is not active. See Section 5.1.5 for details. "SOV Test" can be performed only if "B. PST St" = "Passed" (Baseline SOV test successfully executed), "PST En." = "No", "PST Pos %" = 0.0%, "PST Pr. %" = 0%, "PST Time %" = 0%. See Section 5.1.6 for details.	Start		C	Local, Serial, Bus
PSTSet. (PST Setpoint)	It defines the position to be reached during the PST. It must be considered that 100% corresponds to the fully open and 0% to the fully closed position.	5.0 – 95.0 %	75.0 %	R	Local, Serial, Bus
PST Cal. T. (PST Calculated Time)	It is the calculated time for the PST graphs. See Section 5.2.8 for details.	1.7–2000 sec	0 sec	R	Local, Serial, Bus
PST Max. T. (PST Maximum Time)	It determines the "duration" of the graph of the PST. It is set by default at the same value of "PST Cal. Time" any time that a Baseline Signature is performed and that the "PST Time %" and "PST Set" parameters are set. See 5.2.8 for details. This parameter must be modified only if strictly necessary by expert users. It can affect the operation of the device.	1.7–2000 sec	PST. Cal. Time	R/W	Local, Serial, Bus
B. PST St. (Baseline PST Status)	It is the status of the last Baseline PST or Baseline SOV Test. "Not Done": no Baseline PST or Baseline SOV Test is performed yet. "Progress": during the execution of a Baseline PST or Baseline SOV Test. "Failed": some errors occur during the last Baseline PST or Baseline SOV Test. "Passed": Baseline PST or Baseline SOV Test successfully performed. "Conf_Err": the command is not performed due to wrong configuration or "Pos. Req" not aligned with "Position" or if the command is not available ("PST En." or "Base. S. Status") or "PST Max Time" = 0, CAL or POS alarms active, etc. "Failed" is squelched by "Conf. Err." It is set to "Not Done" after every Calibration or Baseline Sign.	Not Done, Passed, Failed, Progress, Conf_Err.	Not Done	R	Local, Serial, Bus
B. PST Date (Baseline PST Time)	It is the date of the last performed Baseline PST or Baseline SOV Test. It is set to "01-01-2014" after every Calibration or Baseline Sign.	01-01-2014 31-12-2099	01-01-2014	R	Local, Serial, Bus
B. PST Time (Baseline PST Date)	It is the time of the last performed Baseline PST or Baseline SOV Test. It is set to "08:00" after every Calibration or Baseline Sign.	00.00 – 23.59	08.00	R	Local, Serial, Bus

PARAMETERS OF THE "VIEW/SETUP MODE" MENU					
PARAMETER NAME	DESCRIPTION	RANGE	DEFAULT VALUE	R/W (1)	AVAILABLE ON (2) (3)
PST St. (PST Status)	<p>It is the status of the last "Manual PST" or "SOVs Test." Manual PST or SOV B Test: "Not Done": no Manual PST is performed yet. "Progress": during the execution of Manual PST or SOV B Test "Failed": if at least one of the following alarms is generated during the last Manual PST: PSCT, PSSB, PSFB, PSST, PSFT, PSSP, PSSR, PSLB, PSHB, PSNM, PSA and PSB. "Conf_Err": the command is not performed due to wrong configuration or "Pos. Req" not aligned with "Position" or if the command is not available ("PST En." or "B. PST Status") or "PST Max Time" = 0, CAL or POS or HSP or LSP alarms active, etc. Otherwise it is "Passed". "Failed" is squelched by "Conf. Err." See 8 for details.</p> <p>"SOV A Test" or "SOV A – SOV B Test": "Not Done": no SOV Test is performed yet. "Progress": during the execution of SOV Test "Failed": if at least one of the following alarms is generated during the SOV Test: "PSA" or "PSB". "Conf. Err": the command is not performed due to wrong configuration, or "Pos. Req" not aligned with "Position" or CAL or POS or HSP or LSP alarms are active. Otherwise it is "Passed". "Failed" is squelched by "Conf. Err." See 5.1.5 for details.</p> <p>It is set to "Not Done" after every Calibration, Baseline Signature, or Baseline PST.</p>	PST St. (PST Status)	Not Done, Passed, Failed, Progress, Conf_Err.	R	Local, Serial, Bus
M. PST Date (Manual PST Time)	<p>It is the date of the last performed Manual PST or SOV A Test or SOV A – SOV B Test. It is set to "01-01-2014" after every Calibration, Baseline Signature or Baseline PST or Baseline SOV Test.</p>	01-01-2014 31-12-2099	01-01-2014	R	Local, Serial, Bus
M. PST Time (Manual PST Date)	<p>It is the time of the last performed Manual PST or SOV A Test or SOV A – SOV B Test. It is set to "08:00" after every Calibration, Baseline Signature or Baseline PST.or Baseline SOV Test</p>	00.00 – 23.59	08.00	R	Local, Serial, Bus
PST Stored	<p>It indicates the number of the stored PSTs. It is set to "0" after every Calibration or Baseline Signature. It is set to "1" after every Baseline PST successfully done.</p>	0-50	0	R	Local, Serial, Bus
PST ID	<p>It indicates the PST whose data are shown in the "PST Info." The PST ID 1 is dedicated to the Baseline PST. The last PST (not the Baseline PST) has the "PST ID" = 2 and the oldest PST has the "PST ID" = "PST Stored." In case of "SOV A Test" or "SOV A – SOV B Test," PST ID 1 is dedicated to the Baseline SOV Test. The last SOV Test has the "PST ID" = "2" and the oldest SOV Test has the "PST ID" = "PST Stored."</p>	1-50	0	R/W	Local, Serial, Bus

PARAMETERS OF THE "VIEW/SETUP MODE" MENU					
PARAMETER NAME	DESCRIPTION	RANGE	DEFAULT VALUE	R/W (1)	AVAILABLE ON (2) (3)
PST Info	<p>The PST Type, PST Setpoint, PST Source, PST SOV, PST Status, PST date and time, PST Break and Travel Times, PST Break Pressure of the selected PST ("PST ID") are shown. If "PST ID" > "PST Stored" than "all zeros" are shown.</p> <p>Using the Serial Interfaces, the "PST Info" is "included" into the graph of Event (see [1]).</p> <p>PST Type: PST PST Source: "Base" (Baseline PST), "Manual" (Manual PST), "Auto" (Automatic PST), "External Control" (SOV Test). PST Status: "Not Done", "Passed", "Failed", "Conf. Err." PST SOV: "A", "B", "AB." See Section 5 for details.</p>	-	-	R	Local, Serial, Bus
B. PST B. T. (Baseline PST Break Time)	<p>If "Fail Act." = "CL" It is the time measured during the Baseline PST that occurred for going from the Starting Open Position to the 100% - "Op.Break Pos". See 5.1.9 for details.</p> <p>If "Fail Act." = "OP" It is the time measured during the Baseline PST that occurred for going from the Starting Closed Position to the "Cl.Break Pos." See Section 5.1.9 for details.</p>	0-1000.0 sec	0 sec	R	Local, Serial, Bus
M. PST B. T. (Manual PST Break Time)	<p>If "Fail Act." = "CL" It is the time measured during the last Manual PST that occurred for going from the Starting Open Position to the 100% - "Op.Break Pos". See Section 5.1.9 for details.</p> <p>If "Fail Act." = "OP" It is the time measured during the last Manual PST that occurred for going from the Starting Closed Position to the "Cl.Break Pos". See Section 5.1.9 for details.</p>	0-1000.0 sec	0 sec	R	
B. PST T. T. (Baseline PST Travel Time)	<p>If "Fail Act." = "CL" It is the time measured during the Baseline PST that occurred for going from the 100 - "Op. Break Pos".to the 100% - "Op.Break Pos". See Section 5.1.9 for details.</p> <p>If "Fail Act." = "OP" It is the time measured during the Baseline PST that occurred for going from the "Cl.Break Pos". to the "Cl.Break Pos". See Section 5.1.9 for details.</p>	0-1000.0 sec	0 sec	R	Local, Serial, Bus
M. PST T. T. (Manual PST Travel Time)	<p>If "Fail Act." = "CL" It is the time measured during the last Manual PST that occurred for going from the 100 - "Op. Break Pos".to the 100% - "Op.Break Pos". See Section 5.1.9 for details.</p> <p>If "Fail Act." = "OP" It is the time measured during the last Manual PST that occurred for going from the "Cl.Break Pos".to the "Cl.Break Pos". See Section 5.1.9 for details.</p>	0-1000.0 sec	0 sec	R	Local, Serial, Bus

PARAMETERS OF THE "VIEW/SETUP MODE" MENU					
PARAMETER NAME	DESCRIPTION	RANGE	DEFAULT VALUE	R/W (1)	AVAILABLE ON (2) (3)
B. PST B. P. (Baseline PST Break Pressure)	<p>If "Fail Act." = "CL" It is the pressure measured during the Baseline PST when the position reaches the first time 100% - "Op.Break Pos." See Section 5.1.9 for details.</p> <p>If "Fail Act." = "OP" It is the pressure measured during the Baseline PST when the position reaches the first time "Cl.Break Pos." See 5.1.9 for details. If "Act. Mode" ≠ "Single," this pressure value is made by the absolute value of the difference between Pressure 1 and 2.</p>	0 – 400 bar (0 – 5800 psi)	0 bar	R	Local, Serial, Bus
M. PST B. P. (Manual PST Break Pressure)	<p>If "Fail Act." = "CL" It is the pressure measured during the last Manual PST when the position reaches the first time 100% - "Op.Break Pos". See 5.1.9 for details..</p> <p>If "Fail Act." = "OP" It is the pressure measured during the last Manual PST when the position reaches the first time "Cl.Break Pos". See 5.1.9 for details. If "Act. Mode" ≠ "Single", this pressure value is made by the absolute value of the difference between Pressure 1 and 2.</p>	0 – 400 bar (0 – 5800 psi)	0 bar	R	Local, Serial, Bus
Date	It is the date (dd-mm-yyyy) "updated" by the RTC of the IMVS2000v2.	01-01-2014 31-12-2099	actual	R/W	Local, Serial, Bus
Time	It is the time (hh:mm:ss) "updated" by the RTC of the IMVS2000v2.	00.00.00 23.59.59	actual	R/W	Local, Serial, Bus
N.M. Date (Next. Maintenance Date)	It is date used for generating the MNT alarm. See Section 8 for details.	01-01-2014 31-12-2099	01-01-2014	R/W	Local, Serial, Bus
RTC Adjust	<p>RTC Adjust It is the number of seconds to add to the RTC value every 24 hours to increase the RTC precision.</p> <p>It is factory set. Only for expert user.</p>	-127 - 127	Factory set	R/W	Local, Serial, Bus
CFA St. (Common Failure Alarm Status)	It is active when at least an alarm, associated to the Common Failure Alarm, is active (see 8). The CAL alarm is always associated to the Common Failure Alarm. It is cyclically updated every 5 seconds. During the execution of the Calibration, Signatures, FST and PST the updating is stopped.	Not Active, Active	Not Active	R	Local, Serial, Bus
Alarms Status	Each type of alarm (see 8) is listed and it is indicated if it is active ("On") or not active ("Off").	-	-	R	Local, Serial, Bus
Alarms List	Up to 50 alarms' change of status (activation and "clearing") are listed. When an alarm becomes active its acronym (see 8) is listed as "On". When an alarm is cleared its acronym (see 8) is listed as "Off". Using the Local Operator Interface it is possible to see Date and Time of a specific alarm' change of status by selecting it ("UP " and "DOWN" buttons) and then pushing "ENTER". Push "ENTER" another time for returning to the Alarms List.	-	-	R	Local, Serial, Bus

PARAMETERS OF THE "VIEW/SETUP MODE" MENU					
PARAMETER NAME	DESCRIPTION	RANGE	DEFAULT VALUE	R/W (1)	AVAILABLE ON (2) (3)
Clear Alarms List	This command clears the Alarms List. See Section 8 for details.	Start	-	C	Local, Serial, Bus
Reset Alarms	This command "clears" the active alarms. See Section 5.2.7 and Section 8 for details.	Start	-	C	Local, Serial, Bus
AI. PSCL En. (Alarm PSCL Enabled)	Set as "No" it is disabled. Set as "CFA" it is enabled and associated to the "PST St." and to the "CFA St." Set as "ALR" it is enabled and it is associated to the "PST St." but not to the "CFA St." See Sections 5.2.7, 8 and 5.2.3 for details.	CFA, ALR, No	ALR	R/W	Local, Serial, Bus
AI. PSCT En. (Alarm PSCT Enabled)	Set as "No" it is disabled. Set as "CFA" it is enabled and associated to the "PST St." and to the "CFA St." Set as "ALR" it is enabled and it is associated to the "PST St." but not to the "CFA St." See Sections 5.2.7, 8 and 5.2.3 for details.	CFA, ALR, No	CFA	R/W	Local, Serial, Bus
AI. PSSB En. (Alarm PSSB Enabled)	Set as "No" it is disabled. Set as "CFA" it is enabled and associated to the "PST St." and to the "CFA St." Set as "ALR" it is enabled and it is associated to the "PST St." but not to the "CFA St." See Sections 5.2.7, 8 and 5.2.3 for details.	CFA, ALR, No	CFA	R/W	Local, Serial, Bus
AI. PSFB En. (Alarm PSFB Enabled)	Set as "No" it is disabled. Set as "CFA" it is enabled and associated to the "PST St." and to the "CFA St." Set as "ALR" it is enabled and it is associated to the "PST St." but not to the "CFA St." See Sections 5.2.7, 8 and 5.2.3 for details.	CFA, ALR, No	CFA	R/W	Local, Serial, Bus
AI. PSST En. (Alarm PSST Enabled)	Set as "No" it is disabled. Set as "CFA" it is enabled and associated to the "PST St." and to the "CFA St." Set as "ALR" it is enabled and it is associated to the "PST St." but not to the "CFA St." See Sections 5.2.7, 8 and 5.2.3 for details.	CFA, ALR, No	CFA	R/W	Local, Serial, Bus
AI. PSFT En. (Alarm PSFT Enabled)	Set as "No" it is disabled. Set as "CFA" it is enabled and associated to the "PST St." and to the "CFA St." Set as "ALR" it is enabled and it is associated to the "PST St." but not to the "CFA St." See Sections 5.2.7, 8 and 5.2.3 for details.	CFA, ALR, No	CFA	R/W	Local, Serial, Bus
AI. PSSP En. (Alarm PSSP Enabled)	Set as "No" it is disabled. Set as "CFA" it is enabled and associated to the "PST St." and to the "CFA St." Set as "ALR" it is enabled and it is associated to the "PST St." but not to the "CFA St." See Sections 5.2.7, 8 and 5.2.3 for details.	CFA, ALR, No	CFA	R/W	Local, Serial, Bus
AI. PSSR En. (Alarm PSSR Enabled)	Set as "No" it is disabled. Set as "CFA" it is enabled and associated to the "PST St." and to the "CFA St." Set as "ALR" it is enabled and it is associated to the "PST St." but not to the "CFA St." See Sections 5.2.7, 8 and 5.2.3 for details.	CFA, ALR, No	CFA	R/W	Local, Serial, Bus
AI. PSLB En. (Alarm PSLB Enabled)	Set as "No" it is disabled. Set as "CFA" it is enabled and associated to the "PST St." and to the "CFA St." Set as "ALR" it is enabled and it is associated to the "PST St." but not to the "CFA St." See Sections 5.2.7, 8 and 5.2.3 for details.	CFA, ALR, No	CFA	R/W	Local, Serial, Bus
AI. PSHB En. (Alarm PSHB Enabled)	Set as "No" it is disabled. Set as "CFA" it is enabled and associated to the "PST St." and to the "CFA St." Set as "ALR" it is enabled and it is associated to the "PST St." but not to the "CFA St." See Sections 5.2.7, 8 and 5.2.3 for details.	CFA, ALR, No	CFA	R/W	Local, Serial, Bus
AI. PSNM En. (Alarm PSNM Enabled)	Set as "CFA" it is enabled and associated to the "PST St." and to the "CFA St." Set as "ALR" it is enabled and it is associated to the "PST St." but not to the "CFA St." See Sections 5.2.7, 8 and 5.2.3 for details.	CFA, ALR	CFA	R/W	Local, Serial, Bus

PARAMETERS OF THE "VIEW/SETUP MODE" MENU					
PARAMETER NAME	DESCRIPTION	RANGE	DEFAULT VALUE	R/W (1)	AVAILABLE ON (2) (3)
Al. PSA En. (Alarm PSA Enabled)	Set as "No" it is disabled. Set as "CFA" it is enabled and associated to the "PST St." and to the "CFA St." Set as "ALR" it is enabled and it is associated to the "PST St." but not to the "CFA St." See Sections 5.2.7, 8 and 5.2.3 for details.	CFA, ALR, No	CFA	R/W	Local, Serial, Bus
Al. PSB En. (Alarm PSB Enabled)	Set as "No" it is disabled. Set as "CFA" it is enabled and associated to the "PST St." and to the "CFA St." Set as "ALR" it is enabled and it is associated to the "PST St." but not to the "CFA St." See Sections 5.2.7, 8 and 5.2.3 for details.	CFA, ALR, No	CFA	R/W	Local, Serial, Bus
Al. SISA En. (Alarm SISA Enabled)	Set as "No" it is disabled. Set as "CFA" it is enabled and associated to the "CFA St." Set as "ALR" it is enabled but not associated to the "CFA St." See Sections 5.2.7, 8 and 5.2.3 for details.	CFA, ALR, No	ALR	R/W	Local, Serial, Bus
Al. SISB En. (Alarm SISB Enabled)	Set as "No" it is disabled. Set as "CFA" it is enabled and associated to the "CFA St." Set as "ALR" it is enabled but not associated to the "CFA St." See Sections 5.2.7, 8 and 5.2.3 for details.	CFA, ALR, No	ALR	R/W	Local, Serial, Bus
OPOS En. (Alarm OPOS Enabled)	Set as "No" it is disabled. Set as "CFA" it is enabled and associated to the "CFA St." Set as "ALR" it is enabled but not associated to the "CFA St." See Sections 5.2.7, 8 and 5.2.3 for details.	CFA, ALR, No	ALR	R/W	Local, Serial, Bus
Al. CPOS En. (Alarm CPOS Enabled)	Set as "No" it is disabled. Set as "CFA" it is enabled and associated to the "CFA St." Set as "ALR" it is enabled but not associated to the "CFA St." See Sections 5.2.7, 8 and 5.2.3 for details.	CFA, ALR, No	ALR	R/W	Local, Serial, Bus
Al. LSP En. (Alarm LSP Enabled)	Set as "No" it is disabled. Set as "CFA" it is enabled and associated to the "CFA St." Set as "ALR" it is enabled but not associated to the "CFA St." See Sections 5.2.7, 8 and 5.2.3 for details.	CFA, ALR, No	ALR	R/W	Local, Serial, Bus
Al. HSP En. (Alarm HSP Enabled)	Set as "No" it is disabled. Set as "CFA" it is enabled and associated to the "CFA St." Set as "ALR" it is enabled but not associated to the "CFA St." See Sections 5.2.7, 8 and 5.2.3 for details.	CFA, ALR, No	ALR	R/W	Local, Serial, Bus
Al. LPP En. (Alarm LPP Enabled)	Set as "No" it is disabled. Set as "CFA" it is enabled and associated to the "CFA St." Set as "ALR" it is enabled but not associated to the "CFA St." See Sections 5.2.7, 8 and 5.2.3 for details.	CFA, ALR, No	ALR	R/W	Local, Serial, Bus
Al. HPP En. (Alarm HPP Enabled)	Set as "No" it is disabled. Set as "CFA" it is enabled and associated to the "CFA St." Set as "ALR" it is enabled but not associated to the "CFA St." See Sections 5.2.7, 8 and 5.2.3 for details.	CFA, ALR, No	ALR	R/W	Local, Serial, Bus
Al. OPNM En. (Alarm OPNM Enabled)	Set as "CFA" it is enabled and associated to the "CFA St." Set as "ALR" it is enabled but not associated to the "CFA St." See Sections 5.2.7, 8 and 5.2.3 for details.	CFA, ALR	CFA	R/W	Local, Serial, Bus
Al. CLNM En. (Alarm CLNM Enabled)	Set as "CFA" it is enabled and associated to the "CFA St." Set as "ALR" it is enabled but not associated to the "CFA St." See Sections 5.2.7, 8 and 5.2.3 for details.	CFA, ALR	CFA	R/W	Local, Serial, Bus

PARAMETERS OF THE "VIEW/SETUP MODE" MENU					
PARAMETER NAME	DESCRIPTION	RANGE	DEFAULT VALUE	R/W (1)	AVAILABLE ON (2) (3)
AI. OPCT En. (Alarm OPCT Enabled)	Set as "No" it is disabled. Set as "CFA" it is enabled and associated to the "CFA St." Set as "ALR" it is enabled but not associated to the "CFA St." See Sections 5.2.7, 8 and 5.2.3 for details.	CFA, ALR, No	CFA	R/W	Local, Serial, Bus
AI. CLCT En. (Alarm CLCT Enabled)	Set as "No" it is disabled. Set as "CFA" it is enabled and associated to the "CFA St." Set as "ALR" it is enabled but not associated to the "CFA St." See Sections 5.2.7, 8 and 5.2.3 for details.	CFA, ALR, No	CFA	R/W	Local, Serial, Bus
AI. FSCL En. (Alarm FSCL Enabled)	Set as "No" it is disabled. Set as "CFA" it is enabled and associated to the "CFA St." Set as "ALR" it is enabled but not associated to the "CFA St." See Sections 5.2.7, 8 and 5.2.3 for details.	CFA, ALR, No	CFA	R/W	Local, Serial, Bus
AI. SOBT En. (Alarm SOBT Enabled)	Set as "No" it is disabled. Set as "CFA" it is enabled and associated to the "CFA St." Set as "ALR" it is enabled but not associated to the "CFA St." See Sections 5.2.7, 8 and 5.2.3 for details.	CFA, ALR, No	CFA	R/W	Local, Serial, Bus
AI. FOBT En. (Alarm FOBT Enabled)	Set as "No" it is disabled. Set as "CFA" it is enabled and associated to the "CFA St." Set as "ALR" it is enabled but not associated to the "CFA St." See Sections 5.2.7, 8 and 5.2.3 for details.	CFA, ALR, No	CFA	R/W	Local, Serial, Bus
AI. SOTT En. (Alarm SOTT Enabled)	Set as "No" it is disabled. Set as "CFA" it is enabled and associated to the "CFA St." Set as "ALR" it is enabled but not associated to the "CFA St." See Sections 5.2.7, 8 and 5.2.3 for details.	CFA, ALR, No	CFA	R/W	Local, Serial, Bus
AI. FOTT En. (Alarm FOTT Enabled)	Set as "No" it is disabled. Set as "CFA" it is enabled and associated to the "CFA St." Set as "ALR" it is enabled but not associated to the "CFA St." See Sections 5.2.7, 8 and 5.2.3 for details.	CFA, ALR, No	CFA	R/W	Local, Serial, Bus
AI. SCBT En. (Alarm SCBT Enabled)	Set as "No" it is disabled. Set as "CFA" it is enabled and associated to the "CFA St." Set as "ALR" it is enabled but not associated to the "CFA St." See Sections 5.2.7, 8 and 5.2.3 for details.	CFA, ALR, No	CFA	R/W	Local, Serial, Bus
AI. FCBT En. (Alarm FCBT Enabled)	Set as "No" it is disabled. Set as "CFA" it is enabled and associated to the "CFA St." Set as "ALR" it is enabled but not associated to the "CFA St." See Sections 5.2.7, 8 and 5.2.3 for details.	CFA, ALR, No	CFA	R/W	Local, Serial, Bus
AI. SCTT En. (Alarm SCTT Enabled)	Set as "No" it is disabled. Set as "CFA" it is enabled and associated to the "CFA St." Set as "ALR" it is enabled but not associated to the "CFA St." See Sections 5.2.7, 8 and 5.2.3 for details.	CFA, ALR, No	CFA	R/W	Local, Serial, Bus
AI. FCTT En. (Alarm FCTT Enabled)	Set as "No" it is disabled. Set as "CFA" it is enabled and associated to the "CFA St." Set as "ALR" it is enabled but not associated to the "CFA St." See Sections 5.2.7, 8 and 5.2.3 for details.	CFA, ALR, No	CFA	R/W	Local, Serial, Bus

PARAMETERS OF THE "VIEW/SETUP MODE" MENU					
PARAMETER NAME	DESCRIPTION	RANGE	DEFAULT VALUE	R/W (1)	AVAILABLE ON (2) (3)
Al. OHBP En. (Alarm OHBP Enabled)	Set as "No" it is disabled. Set as "CFA" it is enabled and associated to the "CFA St." Set as "ALR" it is enabled but not associated to the "CFA St." See Sections 5.2.7, 8 and 5.2.3 for details.	CFA, ALR, No	CFA	R/W	Local, Serial, Bus
Al. OLBP En. (Alarm OLBP Enabled)	Set as "No" it is disabled. Set as "CFA" it is enabled and associated to the "CFA St." Set as "ALR" it is enabled but not associated to the "CFA St." See Sections 5.2.7, 8 and 5.2.3 for details.	CFA, ALR, No	CFA	R/W	Local, Serial, Bus
Al. CHBP En. (Alarm CHBP Enabled)	Set as "No" it is disabled. Set as "CFA" it is enabled and associated to the "CFA St." Set as "ALR" it is enabled but not associated to the "CFA St." See Sections 5.2.7, 8 and 5.2.3 for details.	CFA, ALR, No	CFA	R/W	Local, Serial, Bus
Al. CLBP En. (Alarm CLBP Enabled)	Set as "No" it is disabled. Set as "CFA" it is enabled and associated to the "CFA St." Set as "ALR" it is enabled but not associated to the "CFA St." See Sections 5.2.7, 8 and 5.2.3 for details.	CFA, ALR, No	CFA	R/W	Local, Serial, Bus
Al. PS1 En. (Alarm PS1 Enabled)	Set as "No" it is disabled. Set as "CFA" it is enabled and associated to the "CFA St." Set as "ALR" it is enabled but not associated to the "CFA St." See Sections 5.2.7, 8 and 5.2.3 for details.	CFA, ALR, No	CFA	R/W	Local, Serial, Bus
Al. PS2 En. (Alarm PS2 Enabled)	Set as "No" it is disabled. Set as "CFA" it is enabled and associated to the "CFA St." Set as "ALR" it is enabled but not associated to the "CFA St." See Sections 5.2.7, 8 and 5.2.3 for details.	CFA, ALR, No	CFA	R/W	Local, Serial, Bus
Al. PPS En. (Alarm PPS Enabled)	Set as "No" it is disabled. Set as "CFA" it is enabled and associated to the "CFA St." Set as "ALR" it is enabled but not associated to the "CFA St." See Sections 5.2.7, 8 and 5.2.3 for details.	CFA, ALR, No	CFA	R/W	Local, Serial, Bus
Al. BUS En. (Alarm BUS Enabled)	Set as "No" it is disabled. Set as "CFA" it is enabled and associated to the "CFA St." Set as "ALR" it is enabled but not associated to the "CFA St." See Sections 5.2.7, 8 and 5.2.3 for details.	CFA, ALR.	CFA	R/W	Local, Serial, Bus
Al. MNT En. (Alarm MNT Enabled)	Set as "No" it is disabled. Set as "CFA" it is enabled and associated to the "CFA St." Set as "ALR" it is enabled but not associated to the "CFA St." See Sections 5.2.7, 8 and 5.2.3 for details.	CFA, ALR, No	ALR	R/W	Local, Serial, Bus
RS232 Baud	For Biffi Use only (Factory Password).	19200, 115200	115200	R/W	Local

PARAMETERS OF THE "VIEW/SETUP MODE" MENU					
PARAMETER NAME	DESCRIPTION	RANGE	DEFAULT VALUE	R/W (1)	AVAILABLE ON (2) (3)
Pres. M.U. (Pressure Measurement Unit)	<p>It defines the measure unit of the pressure.</p> <p>After changing its value the pressures of the "Normal Mode Menu" is immediately aligned to the new setting.</p> <p>The pressure of the graphs (Signatures, FST and PST) is stored according to value of this parameter.</p> <p>The setting of this parameter must be done before starting the commissioning procedure otherwise it is necessary to perform a new commissioning procedure after changing this parameter. See Section 10.7 for details.</p>	bar, psi	bar	R/W	Local, Serial, Bus
CFA Mode (Common Failure Alarm Mode)	<p>It defines the way of work of the "ALARM" digital output.</p> <p>"NC" = normally closed "NO" = normally open See Section 5.2.3 for details.</p>	NO, NC	NO	R/W	Local, Serial, Bus
Op. Cl. Mode (Open Close DO Mode)	<p>It defines the way of work of the "OPEN" and "CLOSED" digital outputs.</p> <p>"NC" = normally closed "NO" = normally open See Section 5.2.3 for details.</p>	NO, NC	NO	R/W	Local, Serial, Bus
Bus Type	If a bus card is present, it specifies the type. "None" = no bus card present.	None, HART, MOD.	NONE	R/W	Local, Serial, Bus
Blue. En. (Bluetooth Enabled)	If set as "Yes" the Bluetooth Interface is enabled.	Yes, No.	Yes	R/W	Local.
Change User PWD (Change User Password)	<p>It is the Password of the Local Operator Interface for logging in as "User".</p> <p>It is possible to set the new value when logged in as "User". The new password is active (the old one is no longer valid) after the log out.</p>	8 characters	00000000	R/W	Local
"M. FST Al. En." (Manual FST Alarm Enabled)	<p>If set as "Yes" the manual FST (through Digital Input or RL A CMD or RL B CMD) causes the updating of the "FST Run Times" parameters and the possible activation of the alarms related to the FST execution (see 5.2.7 and 8 for details).</p> <p>If set as "No" the manual FST (through Hard Wired Commands) does not cause the updating of the "FST Run Times" parameters and the alarms related to the FST execution cannot be activated (see Sections 5.2.7 and 8 for details). In any case the FST graph is stored.</p>	Yes, No.	Yes	R/W	Local, Serial, Bus
DI_SOVA St. (DI_SOVA Status)	<p>It indicates the presence of voltage on the SOLENOID A CONTROL digital input.</p> <p>"High" = Voltage applied. "Low" = Voltage not applied. See Sections 5.2.2 and 9.1 for details.</p>	High, Low		R	Local, Serial, Bus
DI_SOVB St. (DI_SOVB Status)	<p>It indicates the presence of voltage on the SOLENOID B CONTROL digital input.</p> <p>"High" = Voltage applied. "Low" = Voltage not applied. See Sections 5.2.2 and 9.1 for details.</p>	High, Low		R	Local, Serial, Bus

PARAMETERS OF THE "VIEW/SETUP MODE" MENU					
PARAMETER NAME	DESCRIPTION	RANGE	DEFAULT VALUE	R/W (1)	AVAILABLE ON (2) (3)
DI_PST St. (DI_PST Status)	It indicates the presence of voltage on the PST CONTROL digital input. "High" = Voltage applied. "Low" = Voltage not applied. See Sections 5.2.2 and 9.1 for details.	High, Low		R	Local, Serial, Bus
DI_SIS_A St. (DI_SIS_A Status)	It indicates the presence of voltage on the SIS A Terminals. "High" = Voltage applied. "Low" = Voltage not applied. See Section 9.1 for details.	High, Low		R	Local, Serial, Bus
DI_SIS_B St. (DI_SIS_B Status)	It indicates the presence of voltage on the SIS B Terminals. "High" = Voltage applied. "Low" = Voltage not applied. See Section 9.1 for details.	High, Low		R	Local, Serial, Bus
Graph Type	It determines the type of graph to store through the "Store Graph" command.	FST, PST	FST	R/W	Local, Serial, Bus
Graph ID	It determines the FST ID ("Graph Type" = "FST") or PST ID ("Graph Type" = "PST") of graph to store through the "Store Graph" command.	1-50	1	R/W	Local, Serial, Bus
Slot Address	It determines the memory address where the graph will be stored through the "Store Graph" command.	1-20	1	R/W	Local, Serial, Bus
Store Graph	It stores the selected ("Graph Type" and "Graph ID") graph to the set address ("Slot Address").	Start	-	C	Local, Serial, Bus
Clear Slots	It clears all the stored graphs.	Start	-	C	Local, Serial, Bus
Graphs Info	It contains the pieces of information of the stored graph, according to the value of "Slot Address" If the stored graph is a FST, the pieces of information are the ones of the FST Info parameter. If the stored graph is a PST, the pieces of information are the ones of the PST Info parameter.	-	-	R	Local, Serial, Bus

Notes

- (1) Logged in as "Observer", the parameters are readable only.
- (2) Specify the availability of the parameter on each interface: Local (Local Operator Interface), Serial (RS232 and Bluetooth) and Bus Card (see relevant User Manual for details). If a bus card is present a dedicated Menu (called "Bus") is available into the "View Mode Menu" and "Setup Mode Menu" (see relevant User Manual for details).

6.1 Normal Mode Menu

Table 6.

PARAMETERS OF THE "VIEW/SETUP MODE" MENU					
PARAMETER NAME	DESCRIPTION	RANGE	DEFAULT VALUE	R/W (1)	AVAILABLE ON (2) (3)
Position	It is the value of the Position. 0% = Fully Closed, 100% = Fully Open.	0-100 %	actual	R	Local, Serial, Bus
Pos. Req. (Position Request)	It is the value of the Position Request. 0% = Fully Closed, 100% = Fully Open. See Section 5.2.2.2 for details.	0-100 %	actual	R	Local, Serial, Bus
Pres. 1 (Pressure 1)	It is the value of the Pressure of the pressure sensor #1.	0 – 400 bar (0 – 5800 psi)	actual	R	Local, Serial, Bus
Pres. 2 (Pressure 2)	It is the value of the Pressure of the pressure sensor #2. It is applicable only if the pressure sensor #2 is present and enabled ("Act. Mode" = "Double" or "Pr.2 En." = "Yes").	0 – 400 bar (0 – 5800 psi)	actual	R	Local, Serial, Bus
Proc. Pres. (Process Pressure)	It is the value of the Pressure of the process pressure sensor. It is applicable only if the process pressure sensor is present and enabled ("Proc. S." ≠ "None").	0 – 400 bar (0 – 5800 psi)	actual	R	Local, Serial, Bus
Date	It is the time "updated" by the RTC of the IMVS2000v2.	00-00-00 23-59-59	actual	R	Local, Serial, Bus
Time	It is the date "updated" by the RTC of the IMVS2000v2.	01-01-3013 31-12-2099	actual	R	Local, Serial, Bus
Alarms	It indicates the number of the active alarms. See Section 5.2.7 for details.	0-255	actual	R	Local, Serial, Bus

Notes

(a) Specify the availability of the parameter on each interface: Local (Local Operator Interface), Serial (RS232 and Bluetooth) and Bus Card (see relevant User Manual for details).

6.2 “Act.Mode” and “SOVs Qty”

Table 7.

“Act. Mode” “SOVs Qty” “PST Ser. SOVs”	Actuator Type	“Act. Mode” “SOVs Qty” “PST Ser. SOVs”	Actuator Type
“Single” “Simplex” “One”	Single Acting with one SOV. 	“Double-S” “Simplex” “One”	Double Acting with one SOV.
“Single” “Series” “One” or Both Or “Single” “Simplex” “Both”	Single Acting with two SOVs in series. 	“Double-S” “Series” “One” or Both Or “Double-S” “Simplex” “Both”	Double Acting with two SOVs in series.
“Single” “Parallel” NA	Single Acting with two SOVs in parallel. 	“Double-S” “Parallel” NA	Double Acting with two SOVs in parallel.
“Double” Do not care NA	Double Acting with dual SOVs. 		

Section 7: Local Operator Interface

This section describes the Local Operator Interfaces that is available by using the local Push-buttons and the display.

The IMVS2000v2 is fitted with a graphic 128x64 OLED display and 3 push-buttons that allows entering the configuration parameters or to visualize the working data.

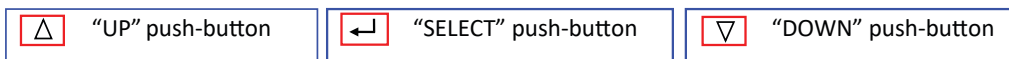

Two push-buttons “DOWN”, “UP” are used to move into the menu and for changing the value of the parameters, while the third “SELECT” is used to enter the selected information and for moving between the sub-menus and for waking-up the IMVS2000v2 (when only the Battery Pack Power Supply is present).

The Local Operator Interface is organized in four different main Menus:

- Normal Mode Menu (see Section 7.1 for details)
- Login Menu (see Section 7.2 for details)
- Setup Mode Menu (see Section 7.3 for details)
- View Mode Menu (see Section 7.3 for details)

Figure 12 The Local Operator Interface is not available when a Biffi Assistant connection is active (see [1])

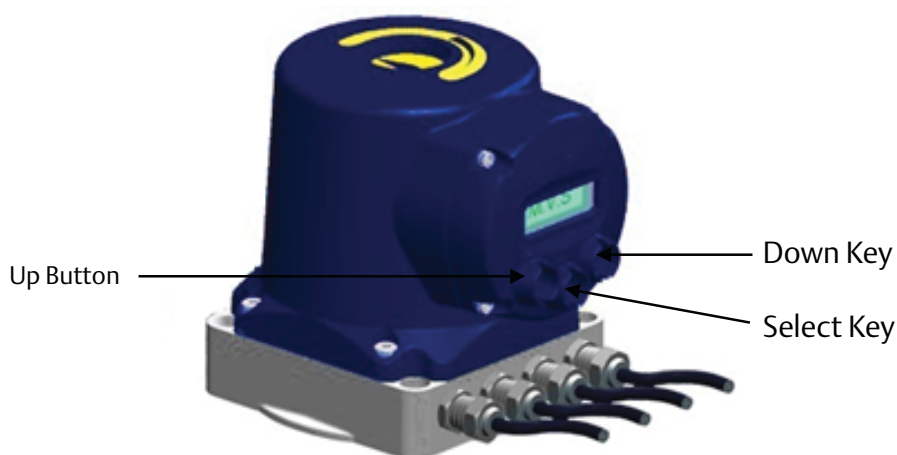

7.1 Normal Mode Menu

The Normal Mode Menu is composed by four display-screens, which are available without any password and can give some general pieces of information.

Figure 13

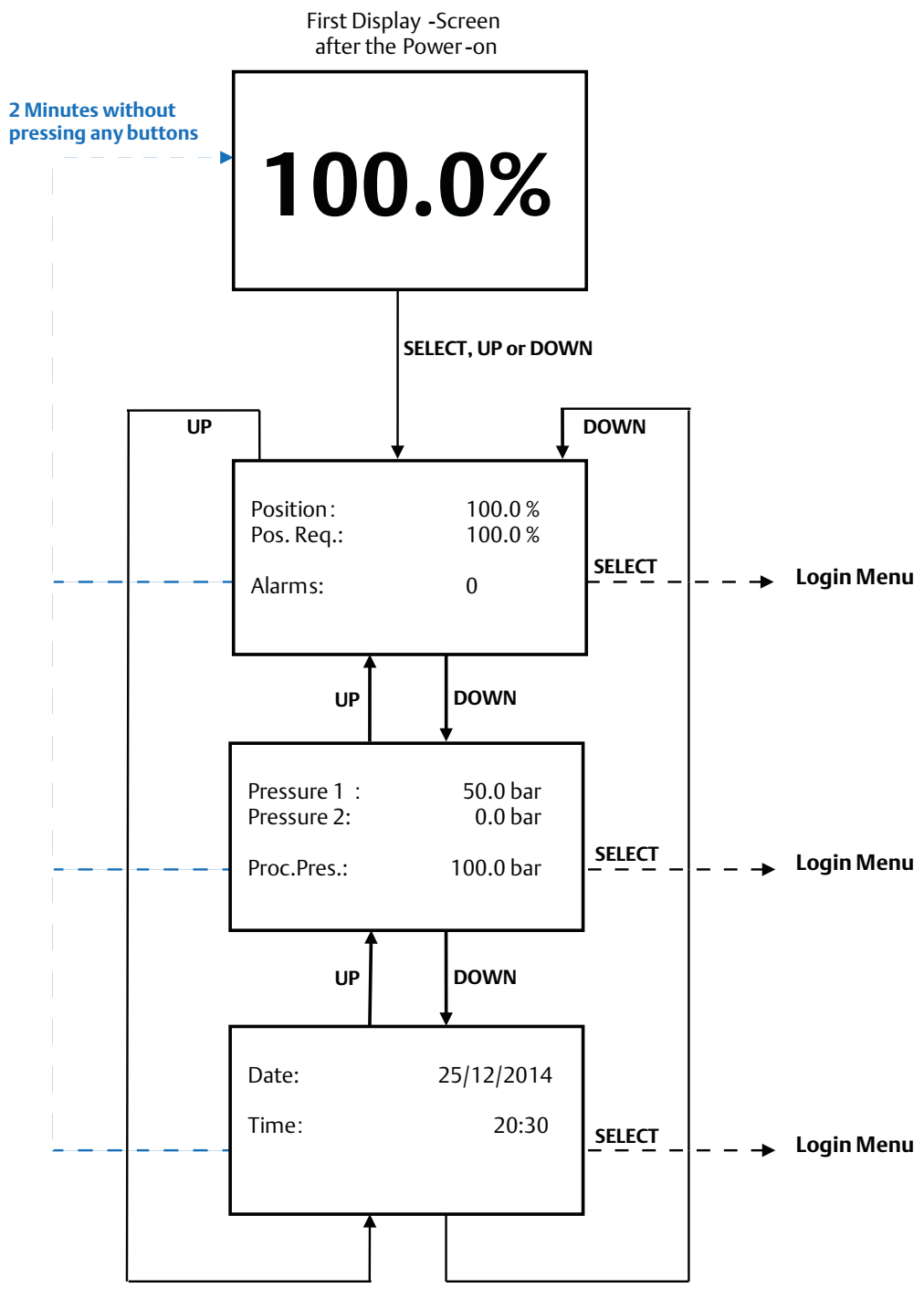

7.2 Log in Menu

The Login Menu allows entering the View/Setup Mode Menu logged in as “Observer,” “User,” “VAC,” or “Factory.”

The “VAC” and “Factory” passwords are reserved for Biffi Service and Production.

Figure 14

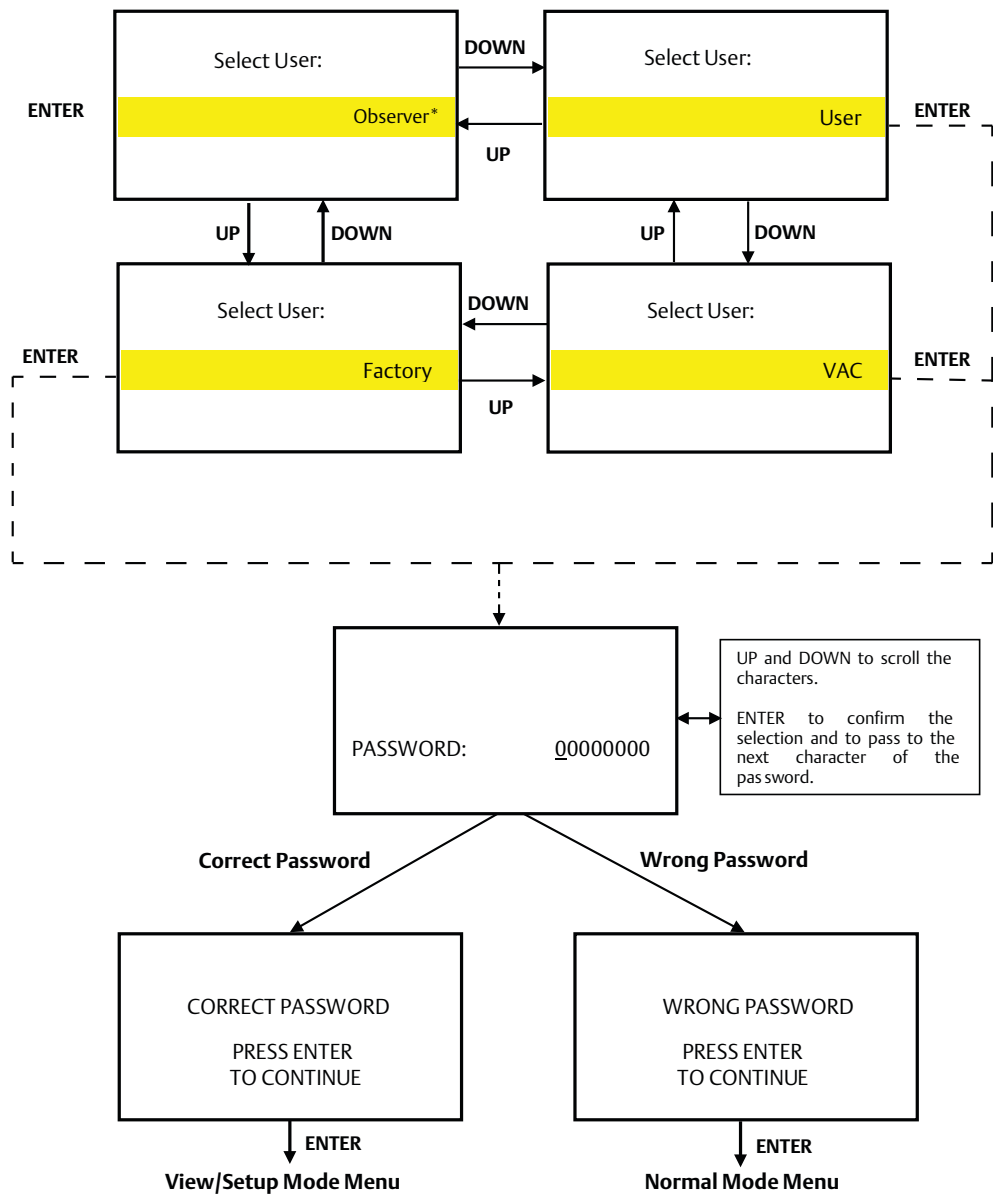

7.3 View/Setup Mode Menu

The View\Setup Mode Menu allows configuring the available parameters (see Section 6 for details).

Logged in as “Observer,” the parameters are readable only.

The current position into the Setup and View Mode menus is yellow-highlighted.

7.3.1 View Graph of the Setup/View Mode Menus

The View Graph of the Setup and View Mode Menus shows the position of each available parameter of these menus.

To help reading the View Graph, a different color is associated to the different menu entries.

Table 8.

	Menu and Sub-Menu
	Exit of Menu and Sub-Menu
	Available Parameter
	Available Command/Calibration
	Available Command/Parameter for VAC only (for Biffi use only)
	Unavailable Command/Parameter (for Biffi use only)

View Mode Menu			
Setup Mode Menu	Exit View-Setup		
	Name Plate	Exit Name Plate	
		Device Data	Exit Device Data
			Dev. Mfr
			Dev. Name
			Dev. Tag
			Dev. S.N.
			Dev. Date
			SW L. Card
			SW D. Card
		Actuator Data	Exit Actuator Data
			Act. Mfr
			Act. Model
			Act. Tag
			Act. S.N.
			Act. Pr. Size
			Act. Date
		Valve Data	Exit Valve Data
			Valve Mfr
			Valve Model
			Valve Tag
			Valve S.N.
			Valve Date

HW Settings	Exit HW Settings
	Act. Mode
	Open. Rot.
	Fail Action
	SOVs Qty
	Pr. S. 1-2
	Proc. S.
	Set Pr. 1-2
	Set Proc.
	RL A Cmd.
	RL B Cmd.
FST Settings	Exit FST Settings
	Sign. En.
	Op. Pos. %
	Cl. Pos. %
	Op. Time %
	Cl. Time %
	FST Pr. %
	H. Pr. Lim.
	L. Pr. Lim.
	H. Proc. L.
	L. Proc. L.
	FST Cyc. L.
	FST Cyc. C.
	FST Ab. C.
PST Settings	Exit PST Settings
	PST En.
	PST Set.
	PST Pos. %
	PST Pr. %
	PST Time %
	PST Ser. SOVs
	PST Cyc. L.
	PST Cyc. C.
	PST Ab. C.
	A. PST En.
	A. PST Per.
	A. PST Date
	A. PST Time
Calibration	Exit Calibration
	Calibration Cmd
	Cal. Date
	Cal. Time
	Cal. Status
	Cal. Enabled

Signatures-FST	Exit Signatures-FST
	Base. Sig. Cmd
	Mnt. Sig. Cmd
	Op. Cal. T.
	Op. Max. T.
	Cl. Cal. T.
	Cl. Max. T.
	Base. S. St.
	B.S. Date
	B.S. Time
	Op. Status
	Cl. Status
	Mnt S. St.
	M.S. Date
	M.S. Time
	FST Stored
	FST ID
	FST Info
	FST Run Times
	Exit FST Run Times
	B. Op. B. T.
	M. Op. B. T.
	B. Op. T. T.
	M. Op. T. T.
	B. Op. B. P.
	M. Op. B. P.
	B. Cl. B. T.
	M. Cl. B. T.
	B. Cl. T. T.
	M. Cl. T. T.
	B. Cl. B. P.
	M. Cl. B. P.
PST Results Settings	Exit PST Results
	Base. PST Cmd
	Manual PST Cmd
	PST Set.
	PST Cal. T.
	PST Max. T.
	B. PST St.
	B. PST Date
	B. PST Time
	PST St.
	M. PST Date
	M. PST Time
	PST Stored
	PST ID
	PST Info
	PST Run Times
	Exit PST Run Times
	B. PST B. T.
	M. PST B. T.
	B. PST T. T.
	M. PST T. T.
	B. PST B. P.
	M. PST B. P.

Date and Time	Exit Date and Time
	Date
	Time
	N.M. Date
	RTC Adjust
Date and Time	Exit Date and Time
	CFA St.
	Alarms Status
	Alarms List
	Clear Alarms List
	Reset Alarms
Alarms Enabled	Exit Alarms Enabled
	Al. PSCL En.
	Al. PSCT En.
	Al. PSSB En.
	Al. PSFB En.
	Al. PSST En.
	Al. PSFT En.
	Al. PSSP En.
	Al. PSSR En.
	Al. PSLB En.
	Al. PSHB En.
	Al. PSNM En.
	Al. PSA En.
	Al. PSB En.
	Al. SISA En.
	Al. SISB En.
	Al. OPOS En.
	Al. CPOS En.
	Al. LSP En.
	Al. HSP En.
	Al. LPP En.
	Al. HPP En.
	Al. OPNM En.
	Al. CLNM En.
	Al. OPCT En.
	Al. CLCT En.
	Al. FSCL En.
	Al. SOBT En.
	Al. FOBT En.
	Al. SOTT En.
	Al. FOTT En.
	Al. SCBT En.
	Al. FCBT En.
	Al. SCTT En.
	Al. FCTT En.
	Al. OHBP En.
	Al. OLBP En.
	Al. CHBP En.
	Al. CLBP En.
	Al. PS1 En.
	Al. PS2 En.
	Al. PPS En.
	Al. POS En.
	Al. BUS En.
	Al. MNT En.

Options	Exit Options
	RS232 Baud
	Pres. M.U.
	CFA Mode
	Op. Cl. Mode
	Bus Type
	Blue. En.
	Change User PWD
	M.FST Al. En.
Sensors Calibration	
Bus (*)	
Factory Settings	Exit Factory Settings
	Pressure Calib.
	Memory Check
	AO Calibration
	Digital Inputs
	Exit Digital Inputs
	DI_SOVA St.
	DI_SOVB St.
	DI_PST St.
	DI_SIS_A St.
	DI_SIS_B St.
	Check DOs
	Restore Defaults
Stored Graphs	Exit Stored Graphs
	Graph Type
	Graph ID
	Slot Address
	Store Graph
	Clear Slots
	Graphs Info

(*): Menu available only if a bus card is present. See the manual dedicated to the specific bus card for details.

7.3.2 Push-buttons Functionality

Two push-buttons “DOWN”, “UP” are used:

- to move into the Menus and the Sub-Menus
- to change the value of a selected parameter

The Menus and Sub-Menus are not “circular”. The “UP” push-button has no effect when pressed on the first entry of a Menu or of a Sub-Menu. The “DOWN” push-button has no effect when pressed on the last entry of a Menu or of a Sub-menu.

The “SELECT” push-button is used:

- to enter and exit the Menus and the Sub-menus
(pressed on **Menus and the Sub-menus** and on **Exits of Menus and Sub-Menus**)
- to select a parameter
(pressed the first time on **Parameter**)
- to set the value of a parameter
(pressed on **Parameter (value)** after setting the new value)
- to launch a command command
(pressed on **Command**)

After pressing the “SELECT” push-button to set a parameter (even if the value is not changed) the current position in the Setup and View Mode Menus go to the “nearer” Exit of Menu and Sub-Menu.

Two minutes after a button is pressed, the first display screen (after the power-on) is shown (see Section 7.1).

This rule is not valid during a command execution. In this case it is necessary to press “ENTER” button in the end of the operation to exit from the menu.

Section 8: Table of Alarms

Table 9.

Alarm	Acronym	Composition	Squelched By (*) (**) (***)
PST Cycle Limit	PSCL	The "PST Cycle Count" exceeds the "PST Cycle Limit" "PST Cyc. Cnt" >= "PST Cyc. Lim." It is cyclically check (period = 30 seconds) The check is interrupted during Calibration, Signatures and PST executions.	<ul style="list-style-type: none"> "Al. PSCL En." = "No" "Reset Alarms" command Power-on Reset
PST Cycle Time Limit	PSCT (***)	The PST Cycle Time is greater than the PST Maximum Time. "B. PST B. T." + "B. PST T. T." > "PST Max. Time" or "M. PST B. T." + "M. PST T. T." > "PST Max. Time" or "Fail Mode"="CL" and Start position <= 100% - "Op. Br. Pos" or "Fail Mode"="CL" and Last Position plotted <100%-"Op. Br. Pos." "Fail Mode"="OP" and Start position >= "Cl. Br. Pos" or "Fail Mode"="OP" and Last Position plotted >0%+"Cl. Br. Pos." A new PST (without the above conditions) resets this alarm.	<ul style="list-style-type: none"> "Al. PSCT En." = "No" "Reset Alarms" command Power-on Reset Calibration Baseline Signature
PST Slow Break Time	PSSB	Last "Manual PST Break Time" is slower than the "Baseline PST Break Time" by more than "PST Time Hysteresis." "M. PST B. T." > "B. PST B. T." * (1 + "PST Time %" / 100) A new PST (without the above condition) resets this alarm.	<ul style="list-style-type: none"> "Al. PSSB En." = "No" "M. PST B. T." = 0 "Reset Alarms" command Power-on Reset Calibration Baseline Signature Baseline PST
PST Fast Break Time	PSFB	Last "Manual PST Break Time" is faster than the "Baseline PST Break Time" by more than "PST Time Hysteresis." "M. PST B. T." < "B. PST B. T." * (1 - "PST Time %" / 100) A new PST (without the above condition) resets this alarm.	<ul style="list-style-type: none"> "Al. PSFB En." = "No" "M. PST B. T." = 0 "Reset Alarms" command Power-on Reset Calibration Baseline Signature Baseline PST
PST Slow Travel Time	PSST	Last "Manual PST Travel Time" is slower than the "Baseline PST Travel Time" by more than "PST Time Hysteresis." "M. PST T. T." > "B. PST T. T." * (1 + "PST Time %" / 100) A new PST (without the above condition) resets this alarm.	<ul style="list-style-type: none"> "Al. PSST En." = "No" "M. PST T. T." = 0 "Reset Alarms" command Power-on Reset Calibration Baseline Signature Baseline PST
PST Fast Travel Time	PSFT	Last "Manual PST Travel Time" is faster than the "Baseline PST Travel Time" by more than "PST Time Hysteresis." "M. PST T. T." < "B. PST T. T." * (1 - "PST Time %" / 100) A new PST (without the above condition) resets this alarm.	<ul style="list-style-type: none"> "Al. PSFT En." = "No" "M. PST B. T." = 0 "Reset Alarms" command Power-on Reset Calibration Baseline Signature Baseline PST
PST Set Point Exceeded	PSSP	Last Manual PST exceeds the "extreme" position reached during the Baseline PST by more than "PST Position Hysteresis." If "Fail Action" = "CL" : B < A - "PST Pos. %" If "Fail Action" = "OP" : B > A + "PST Pos. %" where: A = "extreme" position reached during the "Baseline PST" B = "extreme" position reached during the last "Manual PST" A new PST (without the above condition) resets this alarm.	<ul style="list-style-type: none"> "Al. PSSP En." = "No" "Reset Alarms" command Power-on Reset Calibration Baseline Signature Baseline PST
PST Start Position	PSSR (***)	In case of Fail to Close actuator ("Fail Act." = "CL"): If one of the following conditions is true: - the last PST start position differs from 100% by more than the "Open Position Hysteresis" ("Op. Pos. %"). - osition <= PST Setpoint In case of Fail to Open actuator ("Act. Mode" = "FTO"): If one of the following conditions is true: - the latest PST start position differs from 100% by more than the "Closed Position Hysteresis" ("Cl. Pos. %"). - Position >= PST Setpoint	<ul style="list-style-type: none"> "Al. PSSR En." = "No" "Reset Alarms" command Power-on Reset Calibration Baseline Signature

Alarm	Acronym	Composition	Squelched By (*) (**) (***)
PST Low Break Pressure	PSLB	Last "Manual PST Break Pressure" is lower than the "Baseline PST Break Pressure" by more than "PST Pressure Hysteresis". "M. PST B. P." < "B. PST B. P." * (1 - "PST Pr. %" / 100) A new PST (without the above condition) resets this alarm.	<ul style="list-style-type: none"> "Al. PSLB En." = "No" "M. PST B. P." = 0 "Reset Alarms" command Power-on Reset Calibration Baseline Signature Baseline PST
PST High Break Pressure	PSHB	Latest PST Break Pressure is greater than the "Baseline PST Break Pressure" by more than "PST Pressure Hysteresis". "M. PST B. P." > "B. PST B. P." * (1 + "PST Pr. %" / 100) A new PST (without the above condition) resets this alarm.	<ul style="list-style-type: none"> "Al. PSHB En." = "No" "M. PST B. P." = 0 "Reset Alarms" command Power-on Reset Calibration Baseline Signature Baseline PST
PST Not Moving	PSNM (***)	The actuator/valve does not move during the last PST or "B.PST Status" = "Conf. Err." or "M.PST Status" = "Conf. Err." If "Fail Act." = "CL" It is active if during the PST it is not possible to reach at least the position = 100% - "Op.Break Pos." If "Fail Act." = "OP" It is active if during the PST it is not possible to reach at least the position = "Cl.Break Pos." A new PST (without the above conditions) resets this alarm	<ul style="list-style-type: none"> "Reset Alarms" command Power-on Reset Calibration Baseline Signature
PST SOV A	PSA (***)	The test of the SOVA during the PST does not cause a variation of the pressure or a failure is verified during "SOV A TEST" or "SOV A – SOV B TEST". It is automatically reset when a PST (with the SOV B test) or a "SOV A TEST" or a "SOV A – SOV B TEST" is performed. See Sections 5.1.6 and 5.1.9 for details.	<ul style="list-style-type: none"> "Pr. S. 1-2" = "None" "Act.Mode" = "Double" "SOVs Qty" ≠ "Series" "PST Ser. SOVs" = "One" "Al. PSA En." = "No" "Reset Alarms" command Power-on Reset Calibration Baseline Signature
PST SOV B	PSB (***)	If "SOVs Qty" = "Series" The test of the SOVB during the PST does not cause a variation of the pressure. It is automatically reset when the PST, with the SOVA test, is performed. Else if "SOVs Qty" = "Simplex" The test of the SOVB during SOV TEST does not cause a variation of the pressure or a failure is verified during a "SOV A – SOV B TEST". It is automatically reset when a new SOVs TEST is performed. See Sections 5.1.6 and 5.1.9 for details.	<ul style="list-style-type: none"> "Act.Mode" = "Double" "SOVs Qty" = "Parallel" "PST Ser. SOVs" = "One" "PST En." = "No" "Al. PSB En." = "No" "Reset Alarms" command Power-on Reset Calibration Baseline Signature
SIS A not present	SISA	Loss of power supply dedicated to SOV A. It is cyclically check (period = 30 seconds). The check is interrupted during Calibration, Signatures and PST executions.	<ul style="list-style-type: none"> "Al. SISA En." = "No" "Reset Alarms" command Power-on Reset
SIS B not present	SISB	Loss of power supply dedicated to SOV B. It is cyclically check (period = 30 seconds). The check is interrupted during Calibration, Signatures and PST executions.	<ul style="list-style-type: none"> "Al. SISB En." = "No" "Act. Mode" ≠ "Double" AND "SOVs Qty" = "Simplex" "Reset Alarms" command Power-on Reset
Open Position Out Of Range	OPOS	In case of "Position Request" = 100%: the actual position differs from the Position Request (100%) by more than the "Open Position Hysteresis" ("Op. Pos. %"). $abs(\text{Actual Position} - 100\%) > \text{"Op. Pos. \%"} $ It is cyclically check (period = 30 seconds). The check is interrupted during Calibration, Signatures, FST and PST executions.	<ul style="list-style-type: none"> "Al. OPOS En." = "No" "Reset Alarms" command Power-on Reset

Alarm	Acronym	Composition	Squelched By (*) (**) (***)
Close Position Out Of Range	CPOS	In case of "Position Request" = 0%: the actual position differs from the Position Request (0%) by more than the "Closed Position Hysteresis" ("Cl. Pos. %") (Actual Position - 0%) > "Cl. Pos. %" It is cyclically check (period = 30 seconds). The check is interrupted during Calibration, Signatures, FST and PST executions.	<ul style="list-style-type: none"> "Al. CPOS En." = "No" "Reset Alarms" command Power-on Reset
Low Supply Pressure	LSP	The actual pressure is lower than the "Low Pressure Limit" ("L. Pr. Lim.") Actual Pressure 1 and Pressure 2 < "L. Pr. Lim." It is cyclically check (period = 30 seconds). The check is interrupted during Calibration, Signatures, FST and PST executions.	<ul style="list-style-type: none"> "Pr. S.1 -2." = "None" "Act.Mode" = "Double" Al. LSP En." = "No" "Reset Alarms" command Power-on Reset "Act. Mode" = "Single" AND "Fail Act. " = "CL" AND "Pos. Req" = 0% "Act. Mode" = "Single" AND "Fail Act. " = "OP" AND "Pos. Req" = 100%
High Supply Pressure	HSP	The actual pressure is greater than the "High Pressure Limit" ("H. Pr. Lim.") Actual Pressure 1 and Pressure 2 > "H. Pr. Lim." It is cyclically check (period = 30 seconds). The check is interrupted during Calibration, Signatures, FST and PST executions. Starting from Logic Card FW Revision 1.00.01, if HSP is active, the PST is not executed.	<ul style="list-style-type: none"> Pr. S.1 -2." = "None" "Act.Mode" = "Double" Al. HSP En." = "No" "Reset Alarms" command Power-on Reset "Act. Mode" = "Single" AND "Fail Act. " = "CL" AND "Pos. Req" = 0% "Act. Mode" = "Single" AND "Fail Act. " = "OP" AND "Pos. Req" = 100%
Low Process Pressure	LPP	The actual process pressure is lower than the "Low Process Pressure Limit" ("L. Proc. Lim.") Actual Process Pressure < "L. Proc. Lim." It is cyclically check (period = 30 seconds). The check is interrupted during Calibration, Signatures and PST executions. Starting from Logic Card FW Revision 1.00.01, if HSP is active, the PST is not executed.	<ul style="list-style-type: none"> "Proc. S." = "None" Al. LPP En." = "No" "Reset Alarms" command Power-on Reset
High Process Pressure	HPP	The actual process pressure is greater than the "High Process Pressure Limit" ("H. Proc. Lim.") Actual Process Pressure > "H. Proc. Lim." It is cyclically check (period = 30 seconds). The check is interrupted during Calibration, Signatures and PST executions.	<ul style="list-style-type: none"> "Proc. S." = "None" Al. HPP En." = "No" "Reset Alarms" command Power-on Reset
Opening not move	OPNM (****)	The actuator/valve does not move during the last Opening FST or "Base S.Status" = "Conf. Err" or "Mnt S.Status" = "Conf. Err." It is active if during the last Opening FST it is not possible to reach at least the position = "Cl.Break Pos" A new Opening FST (without the above condition) resets this alarm.	<ul style="list-style-type: none"> "Reset Alarms" command Power-on Reset Calibration
Closing not move	CLNM (****)	The actuator/valve does not move during the last Closing FST or "Base S.Status" = "Conf. Err" or "Mnt S.Status" = "Conf. Err." It is active if during the last Closing FST it is not possible to reach at least the position = 100% - "Op.Break Pos." A new Closing FST (without the above condition) resets this alarm.	<ul style="list-style-type: none"> "Reset Alarms" command Power-on Reset Calibration
Opening Cycle Time Limit	CLNM (****)	Start position >= 0% + "Cl. Br. Pos" OR Last Position plotted < 100% - "Op. Br. Pos." A new Opening FST (without the above conditions) resets this alarm.	<ul style="list-style-type: none"> "Al. OPCT En." = "No" "Reset Alarms" command Power-on Reset Calibration
Closing Cycle Time Limit	CLCT (****)	Start position <= 10.0% - "Op. Br. Pos" OR Last Position plotted > 0% + "Cl. Br. Pos." A new Closing FST (without the above conditions) resets this alarm.	<ul style="list-style-type: none"> "Al. OPCT En." = "No" "Reset Alarms" command Power-on Reset Calibration

Alarm	Acronym	Composition	Squelched By (*) (**) (***)
FST Cycle Limit	FSCL	The "FST Cycle Count" exceeds the "FST Cycle Limit" "FST Cyc. Cnt" >= "FST Cyc. Lim." It is cyclically check (period = 30 seconds). The check is interrupted during Calibration, Signatures and PST executions.	<ul style="list-style-type: none"> "Al. FSCL En." = "No" "Reset Alarms" command Power-on Reset
Slow Open Break Time	SOBT	Last "Maintenance Opening Break Time" is slower than the "Baseline Opening Break Time" by more than "Opening Time Hysteresis." "M. Op. B. T." > "B. Op. B. T." * (1 + "Op. Time %" / 100) A new Opening FST (without the above condition) resets this alarm.	<ul style="list-style-type: none"> "Al. SOBT En." = "No" "M. Op. B. T." = 0 "Reset Alarms" command Power-on Reset Calibration Baseline Signature
Fast Open Break Time	FOBT	Last "Maintenance Opening Break Time" is faster than the "Baseline Opening Break Time" by more than "Opening Time Hysteresis." "M. Op. B. T." < "B. Op. B. T." * (1 - "Op. Time %" / 100) A new Opening FST (without the above condition) resets this alarm.	<ul style="list-style-type: none"> "Al. FOBT En." = "No" "M. Op. B. T." = 0 "Reset Alarms" command Power-on Reset Calibration Baseline Signature
Slow Open Travel Time	SOTT	Last "Maintenance Opening Travel Time" is slower than the "Baseline Opening Travel Time" by more than "Opening Time Hysteresis." "M. Op. T. T." > "B. Op. T. T." * (1 + "Op. Time %" / 100) A new Opening FST (without the above condition) resets this alarm.	<ul style="list-style-type: none"> "Al. SOTT En." = "No" "M. Op. T. T." = 0 "Reset Alarms" command Power-on Reset Calibration Baseline Signature
Fast Open Travel Time	FOTT	Last "Maintenance Opening Travel Time" is faster than the "Baseline Opening Travel Time" by more than "Opening Time Hysteresis." "M. Op. T. T." < "B. Op. T. T." * (1 - "Op. Time %" / 100) A new Opening FST (without the above condition) resets this alarm.	<ul style="list-style-type: none"> "Al. FOTT En." = "No" "M. Op. T. T." = 0 "Reset Alarms" command Power-on Reset Calibration Baseline Signature
Slow Close Break Time	SCBT	Last "Maintenance Closing Break Time" is slower than the "Baseline Closing Break Time" by more than "Closing Time Hysteresis". "M. Cl. B. T." >= "B. Cl. B. T." * (1 + "Cl. Time %" / 100) A new Closing FST (without the above condition) resets this alarm.	<ul style="list-style-type: none"> "Al. SCBT En." = "No" "M. Cl. B. T." = 0 "Reset Alarms" command Power-on Reset Calibration Baseline Signature
Fast Close Break Time	FCBT	Last "Maintenance Closing Break Time" is faster than the "Baseline Closing Break Time" by more than "Closing Time Hysteresis". "M. Cl. B. T." < "B. Cl. B. T." * (1 - "Cl. Time %" / 100) A new Closing FST (without the above condition) resets this alarm.	<ul style="list-style-type: none"> "Al. FCBT En." = "No" "M. Cl. B. T." = 0 "Reset Alarms" command Power-on Reset Calibration Baseline Signature
Slow Close Travel Time	SCTT	Last "Maintenance Closing Travel Time" is slower than the "Baseline Closing Travel Time" by more than "Closing Time Hysteresis". "M. Cl. T. T." > "B. Cl. T. T." * (1 + "Cl. Time %" / 100) A new Closing FST (without the above condition) resets this alarm.	<ul style="list-style-type: none"> "Al. SCTT En." = "No" "M. Cl. T. T." = 0 "Reset Alarms" command Power-on Reset Calibration Baseline Signature
Fast Close Travel Time	FCTT	Last "Maintenance Closing Travel Time" is faster than the "Baseline Closing Travel Time" by more than "Closing Time Hysteresis". "M. Cl. T. T." < "B. Cl. T. T." * (1 - "Cl. Time %" / 100) A new Closing FST (without the above condition) resets this alarm.	<ul style="list-style-type: none"> "Al. FCTT En." = "No" "M. Cl. T. T." = 0 "Reset Alarms" command Power-on Reset Calibration Baseline Signature
Open High Break Pressure	OHBP	Last "Maintenance Opening Break Pressure" is greater than the "Baseline Opening Break Pressure" by more than "FST Pressure Hysteresis". "M. Op. B. P." > "B. Op. B. P." * (1 + "FST Pr. %" / 100) A new Opening FST (without the above condition) resets this alarm.	<ul style="list-style-type: none"> "Al. OHB En." = "No" "M. Op. B. P." = 0 "Reset Alarms" command Power-on Reset Calibration Baseline Signature
Open Low Break Pressure	OLBP	Last "Maintenance Opening Break Pressure" is lower than the "Baseline Opening Break Pressure" by more than "PST Pressure Hysteresis". "M. Op. B. P." < "B. Op. B. P." * (1 - "FST Pr. %" / 100) A new Opening FST (without the above condition) resets this alarm.	<ul style="list-style-type: none"> "Al. OLB En." = "No" "M. Op. B. P." = 0 "Reset Alarms" command Power-on Reset Calibration Baseline Signature

Alarm	Acronym	Composition	Squelched By (*) (**) (***)
Close High Break Pressure	CHBP	Last "Maintenance Closing Break Pressure" is greater than the "Baseline Closing Break Pressure" by more than "FST Pressure Hysteresis". "M. Cl. B. P." > "B. Cl. B. P." * (1 + "FST Pr. %" / 100) A new Closing FST (without the above condition) resets this alarm.	<ul style="list-style-type: none"> "Al. CHBP En." = "No" "M. Cl. B. P." = 0 "Reset Alarms" command Power-on Reset Calibration Baseline Signature
Close Low Break Pressure	CLBP	Last "Maintenance Closing Break Pressure" is lower than the "Baseline Closing Break Pressure" by more than "PST Pressure Hysteresis". "M. Cl. B. P." < "B. Cl. B. P." * (1 - "FST Pr. %" / 100) A new Closing FST (without the above condition) resets this alarm.	<ul style="list-style-type: none"> "Al. CLBP En." = "No" "M. Cl. B. P." = 0 "Reset Alarms" command Power-on Reset Calibration Baseline Signature
Pressure Sensor 1	PS1	Failure of the Pressure Sensor 1. It is cyclically check (period = 5 seconds).	<ul style="list-style-type: none"> "Pr. S. 1-2" = "None" "Al. PS1 En." = "No" "Reset Alarms" command Power-on Reset
Pressure Sensor 2	PS2	Failure of the Pressure Sensor 2. It is cyclically check (period = 5 seconds).	<ul style="list-style-type: none"> "Pr. S. 1-2" = "None" "Act. Mode." = "Single" "Al. PS2 En." = "No" "Reset Alarms" command Power-on Reset
Process Pressure Sensor	PPS	Failure of the Process Pressure Sensor. It is cyclically check (period = 5 seconds).	<ul style="list-style-type: none"> "Proc. S." = "None" "Al. PPS En." = "No" "Reset Alarms" command Power-on Reset
Position Sensor	POS	Failure of the Position Sensor. It is cyclically check (period = 5 seconds).	<ul style="list-style-type: none"> "Reset Alarms" command Power-on Reset
Bus Card	BUS	Internal communication problems with the bus card. It is cyclically check (period = 30 seconds).	<ul style="list-style-type: none"> "Al. BUS En." = "No" "Reset Alarms" command Power-on Reset
Maintenance	MNT	The actual Date is greater than the "Next Maintenance Date". "Next Mnt Date" >= Actual Date It is cyclically check (period = 30 seconds).	<ul style="list-style-type: none"> "Al. MNT En." = "No" "Reset Alarms" command Power-on Reset
Calibration	CAL	"Cal. Status" ≠ "Passed" If "Act. Mode", "Open Rot.", "Fail Action" or "SOVs Qty" have not the same value they had during the last valid Calibration ("Cal. Status" = "Passed"). The status of this alarm is checked after every Power-on Reset and every time the value of "Act. Mode", "Open Rot.", "Fail Action" or "SOVs Qty" changes. If this alarm is active is not possible to perform PST and Signatures.	
Power On Reset	POWER	It is not a real alarm; it is just logged in the "Alarms List" after a reset (power cycle) of the device.	Nothing
Reset Alarm	RESET	It is not a real alarm; it is just logged in the "Alarms List" after using the "Reset Alarms" command.	Nothing

Notes:

- (*): See Section 6 for details about IMVS2000v2 parameters.
- (**): The Cyclically Check alarms are not permanently squelched by the "Reset Alarms" command and by the "Power on Reset", if the alarm conditions keep existing, they will be activated during the next check (see Section 5.2.7).
- (***): These PST alarms can be generated by the Baseline PST.
- (****): These FST alarms can be generated by the Baseline Signature.

Section 9: Wiring Diagrams – Signals Description

9.1 Signals Description

9.1.1 Standard Signals

Figure 15

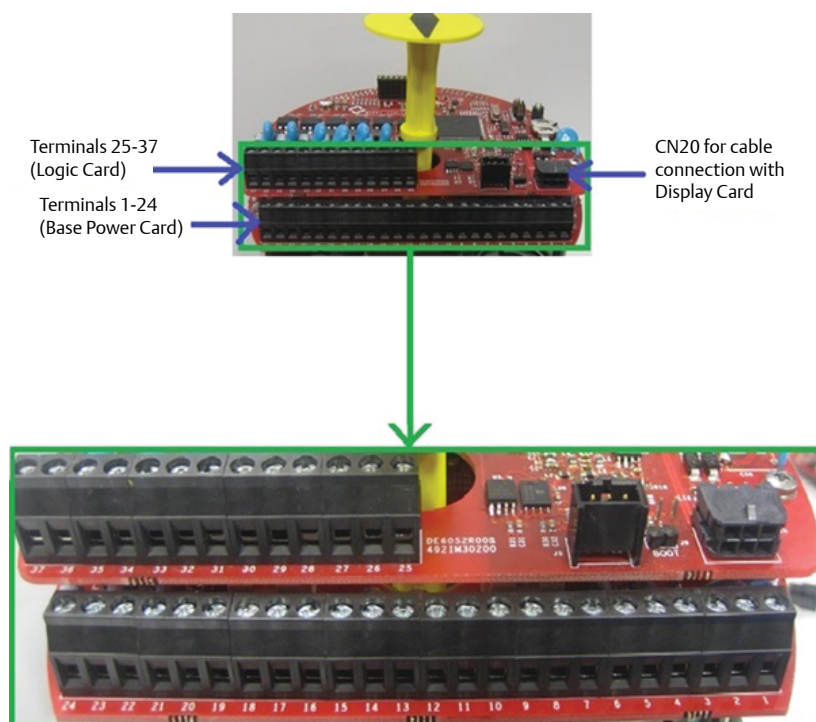

The previous figure shows the standard terminals (without optional cards) of the IMVS2000v2. The table below describes the signals of the standard terminals of the IMVS2000v2.

Table 10.

Type	#	Signal Name	Description
EARTH	1	EARTH	Protection Earth.
	2	EARTH	Protection Earth.
	37	EARTH	Protection Earth.
Main Supply	3	+Vin	Positive Input of the power supply of the electronic cards.
	4	-Vin	Negative Input of the power supply of the electronic cards.
SIS A	5	+SIS A	Positive Input of the power supply dedicated to the SOVA.
	6	- SIS A	Negative Input of the power supply dedicated to the SOVA.
	7	+ SIS A (aux)	+ SIS A Auxiliary contact used for internal wired connection (see Section 9.2 for details).
	8	-SIS A (aux)	- SIS A Auxiliary contact used for internal wired connection (see Section 9.2 for details).
SOVA	9	SOV A+(NC)	If used, it must be connected to the positive terminal of the SOVA (see Section 9.2 for details).
	10	SOV A+(NO)	If used, it must be connected to the positive terminal of the SOVA (see Section 9.2 for details).
	11	SOVA-	It must be connected to negative terminal of the SOVA (see Section 9.2 for details). It is internally connected to – SIS A.
SIS B	12	+SIS B	Positive Input of the power supply dedicated to the SOVB.
	13	- SIS B	Negative Input of the power supply dedicated to the SOVB.
	14	+ SIS B (aux)	+ SIS B Auxiliary contact used for internal wired connection (see Section 9.2 for details).
	15	-SIS B (aux)	- SIS B Auxiliary contact used for internal wired connection (see Section 9.2 for details).
SOVB	16	SOV B+(NC)	If used, it must be connected to the positive terminal of the SOVB (see Section 9.2 for details).
	17	SOV B+(NO)	If used, it must be connected to the positive terminal of the SOVB (see Section 9.2 for details).
	18	SOVB-	It must be connected to negative terminal of the SOVB (see Section 9.2 for details). It is internally connected to – SIS B.
Digital Inputs	19	SOLENOID A CONTROL	It is used for controlling the SOVA. Its functionality depends on the device configuration (see Section 5.2.2 for details).
	20		
	21	SOLENOID B CONTROL	It is used for controlling or testing (SOV TEST) the SOVB. Its functionality depends on the device configuration (see Section 5.2.2 for details).
	22		
	23	PST CONTROL	It is used for performing a "Manual PST" or a "SOV A TEST" or a "SOV A – SOV B TEST" (see Section 5.2.2 for details).
24			
Digital Outputs	25	OPEN SIGNAL	It is a solid state dry contact associated to the Open Position. It can be set as Normally Open or Normally Closed (see Section 5.2.3 for details).
	26		
	27	CLOSE SIGNAL	It is a solid state dry contact associated to the Closed Position. It can be set as Normally Open or Normally Closed (see Section 5.2.3 for details).
	28		
	29	COMMON FAILURE ALARM	It is a solid state dry contact associated to "C.F.A St.". It can be set as Normally Open or Normally Closed (see Section 5.2.3 for details).
	30		
	31	PST IN PROGRESS	It is a solid state dry contact that closes during the PST execution or during SOVs TEST (see Section 5.2.3 for details).
	32		
	33	PST PASSED	It is a solid state dry contact associated to "PST Status" (see Section 5.2.3 for details).
	34		
35	PST FAILED	It is a solid state dry contact associated to "PST Status" (see Section 5.2.3 for details).	
36			

9.1.2 Optional Card Signals

9.1.2.1 Hart Card Signals

Figure 16

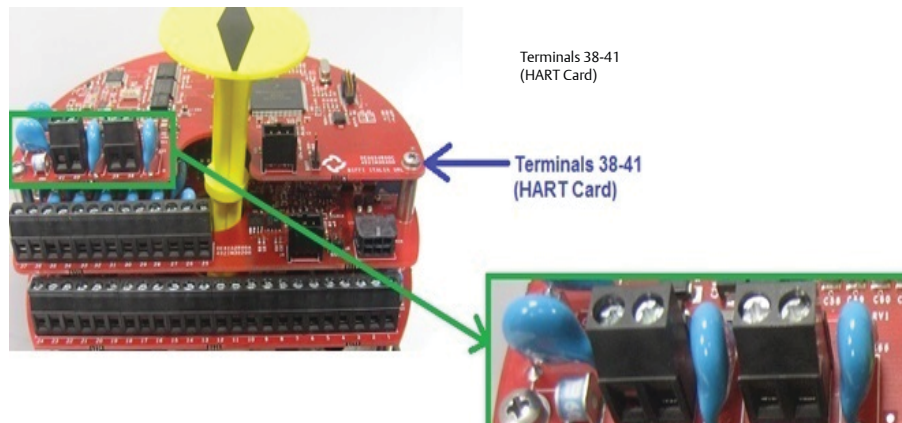

The previous figure shows the terminals of the IMVS2000v2 HART Card.

The table below describes the signals of the of the HART Card terminals (for details see [2]).

Table 11.

Type	#	Signal Name	Description
HART	38	HART_1	Hart + 4-20 mA loop signal.
	39	HART_2	Hart +4-20 mA loop signal.
SHIELD	40	SHIELD	Available connection for the cable Shield. It is connected to the Protection Earth through a 2.2nF 4KV capacitor.
EARTH	41	EARTH	Protection Earth.

9.1.2.2 Modbus Card Signals

Figure 17

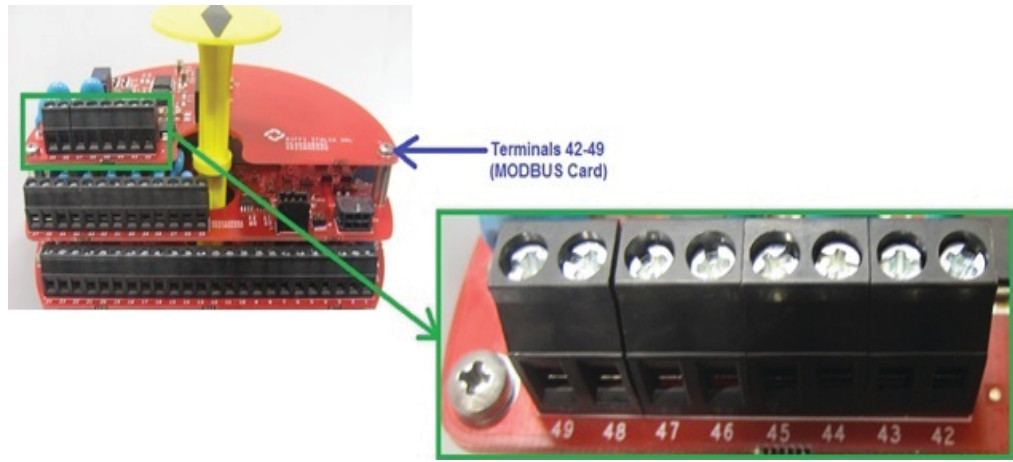

The previous figure shows the terminals of the IMVS2000v2 MODBUS Card.

The table below describes the signals of the of the MODBUS Card terminals (for details see [3]).

Table 12.

Type	#	Signal Name	Description
MODBUS	42, 45	MODBUS-B	Modbus data line B (+).
	43, 46	MODBUS-A	Modbus data line A (-).
	44, 47	MODBUS-R	Modbus Reference line.
SHIELD	48	SHIELD	Available connection for the cable Shield. It is connected to the Protection Earth through a 2.2nF 4KV capacitor.
EARTH	49	EARTH	Protection Earth.

9.2 Wiring Diagrams

9.2.1 Configuration A – Wiring Diagram

Figure 18

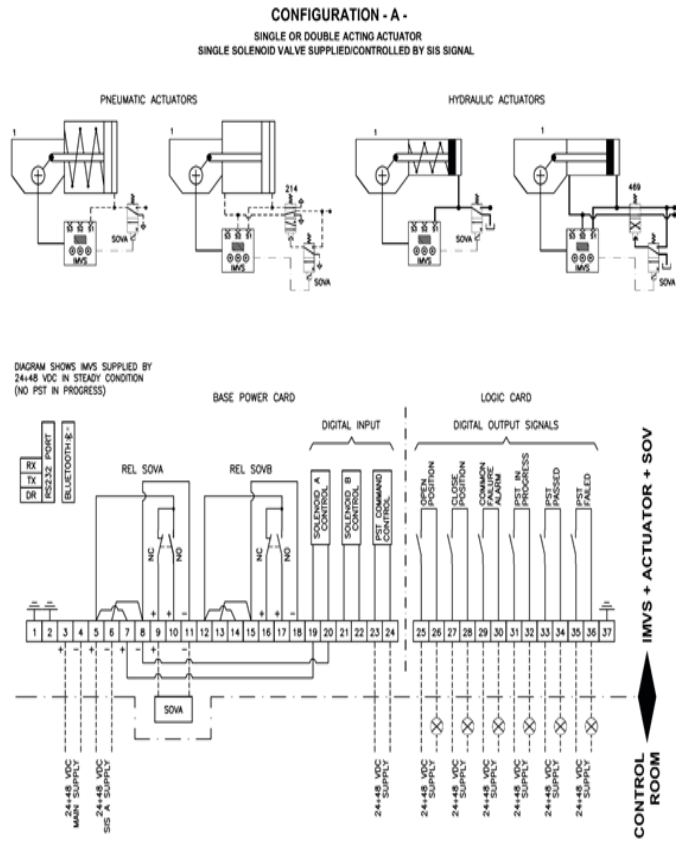

Mandatory Connections:

- MAIN SUPPLY (terminals 3-4)
- SIS A SUPPLY (terminals 5-6)
- SOVA (terminals 9-11)

All the other connections are optional (see Section 9.1.1 for details).

9.2.3 Configuration C – Wiring Diagram

Figure 20

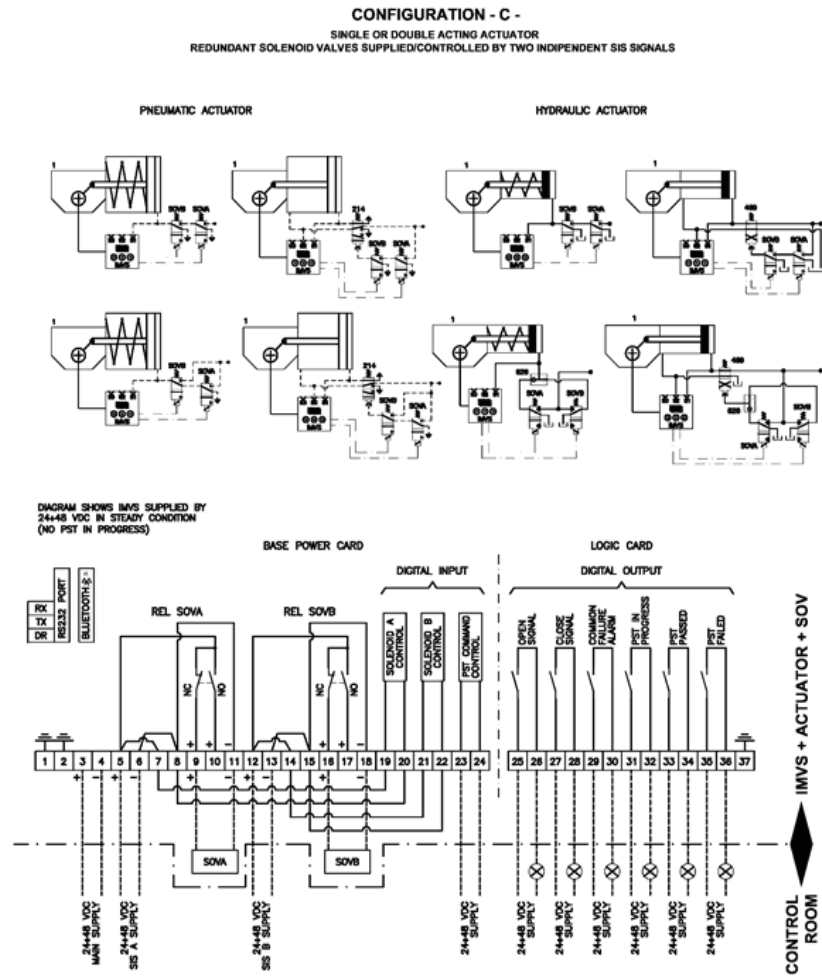

Mandatory Connections:

- MAIN SUPPLY (terminals 3-4)
- SIS A SUPPLY (terminals 5-6)
- SIS B SUPPLY (terminals 12-13)
- SOVA (terminals 9-11)
- SOVB (terminals 16-18)

All the other connections are optional (see Section 9.1.1 for details).

9.2.4 Configuration D – Wiring Diagram

Figure 21

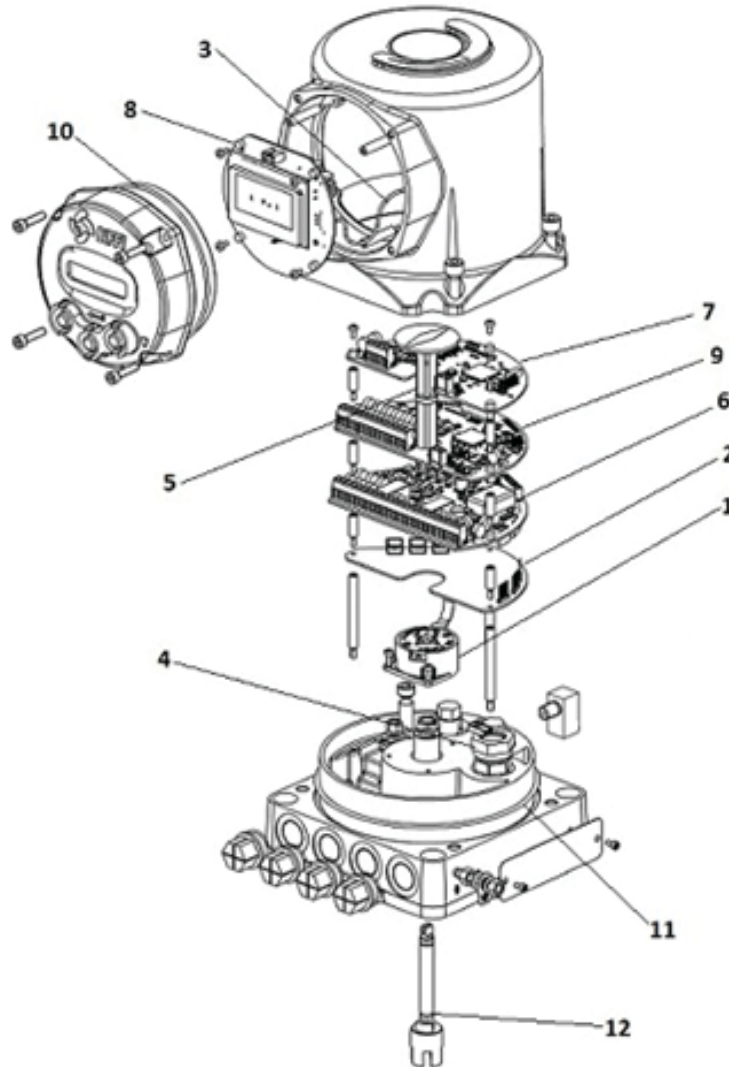

Mandatory Connections:

- MAIN SUPPLY (terminals 5-6)
- SOVA (terminals 9-11)
- SOVB (terminals 16-18)

Recommended Connections:

- SOLENOID A CONTROL (terminals 19-20)
- SOLENOID B CONTROL (terminals 21-22)

All the other connections are optional (see Section 9.1.1 for details).

9.2.5 Configuration E – Wiring Diagram

Figure 22

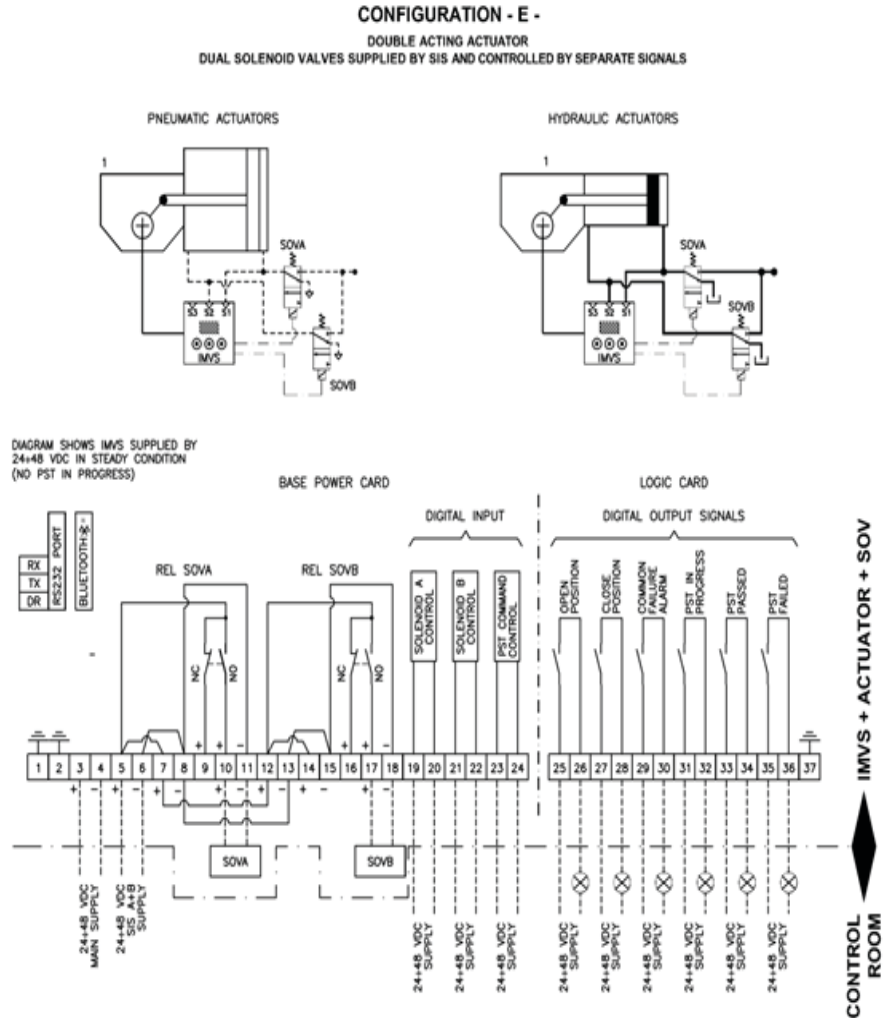

Mandatory Connections:

- MAIN SUPPLY (terminals 3-4)
- SIS A SUPPLY (terminals 5-6)
- SOVA (terminals 9-11)
- SOVB (terminals 16-18)

Recommended Connections:

- SOLENOID A CONTROL (terminals 19-20)
- SOLENOID B CONTROL (terminals 21-22)

All the other connections are optional (see Section 9.1.1 for details).

9.2.6 Configuration F – Wiring Diagram

Figure 23

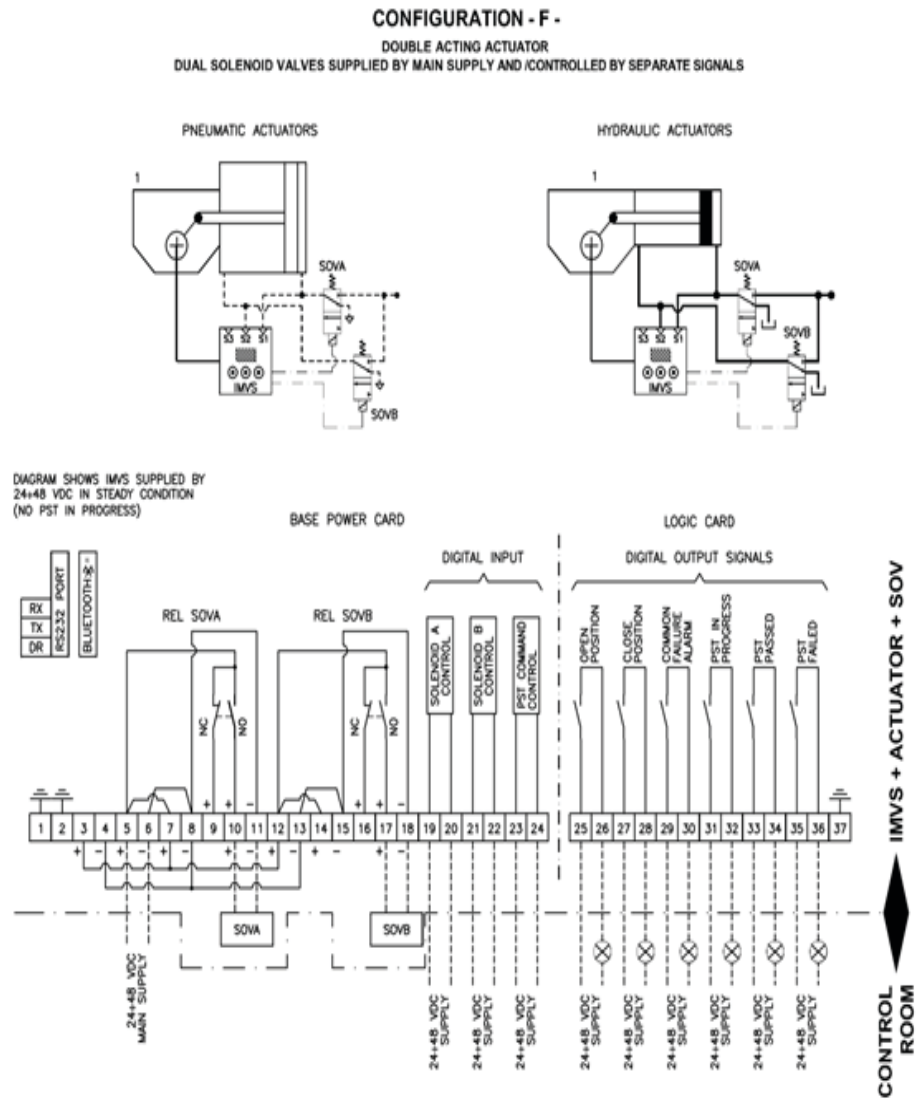

Mandatory Connections:

- MAIN SUPPLY (terminals 5-6)
- SOVA (terminals 9-11)
- SOVB (terminals 16-18)

Recommended Connections:

- SOLENOID A CONTROL (terminals 19-20)
- SOLENOID B CONTROL (terminals 21-22)

All the other connections are optional (see Section 9.1.1 for details).

9.2.7 Configuration G – Wiring Diagram

Figure 24

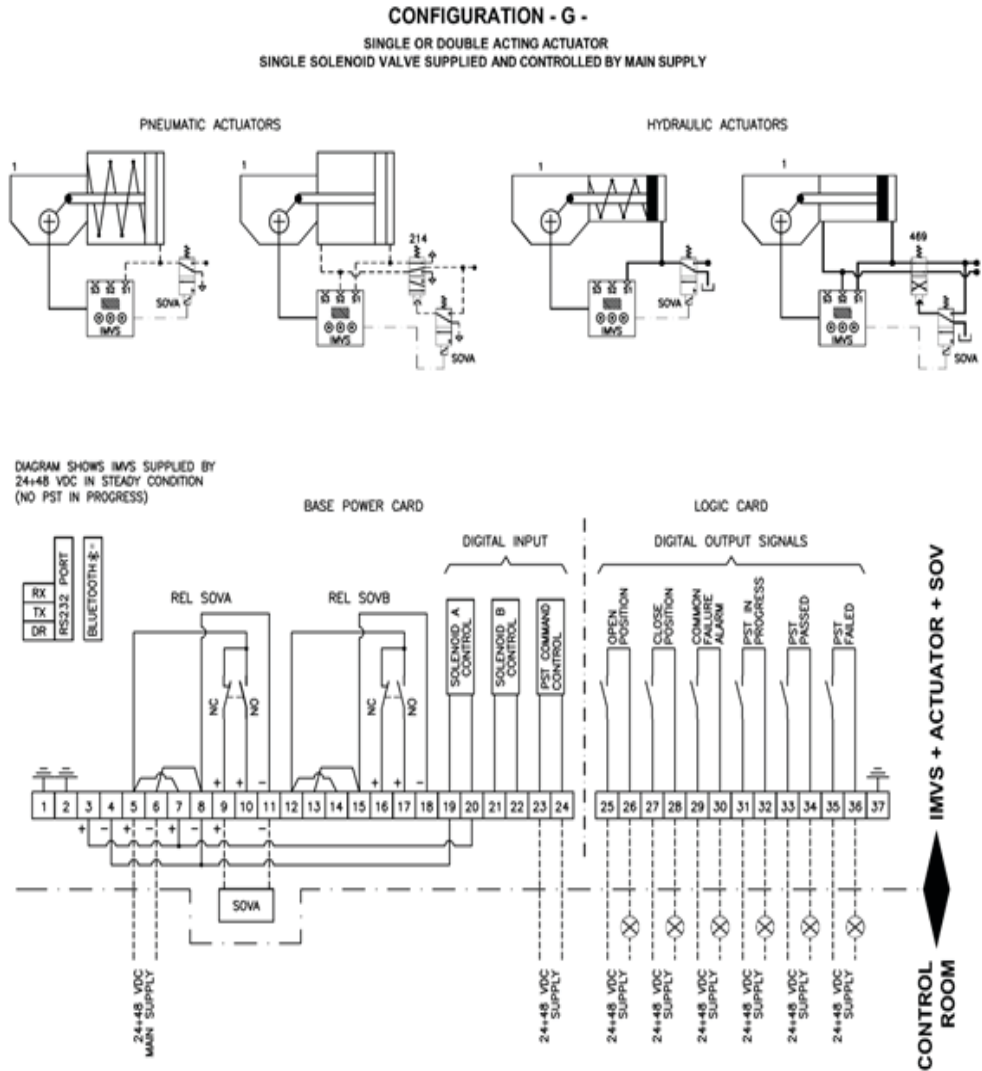

Mandatory Connections:

- MAIN SUPPLY (terminals 5-6)
- SOVA (terminals 9-11)

All the other connections are optional (see Section 9.1.1 for details).

9.2.8 Configuration H – Wiring Diagram

Figure 25

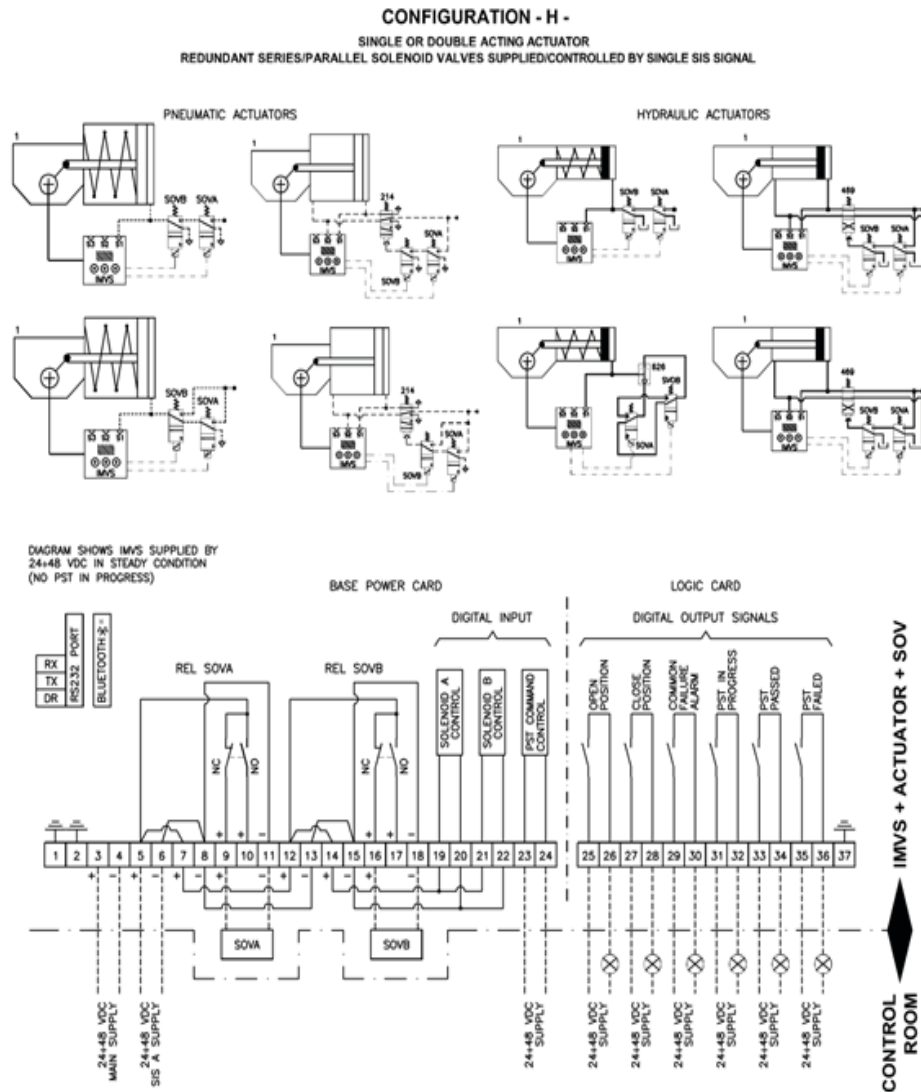

Mandatory Connections:

- MAIN SUPPLY (terminals 3-4)
- SIS A SUPPLY (terminals 5-6)
- SOVA (terminals 9-11)
- SOVB (terminals 16-18)

All the other connections are optional (see Section 9.1.1 for details).

9.2.9 Hart Card – Wiring Diagram

Figure 26

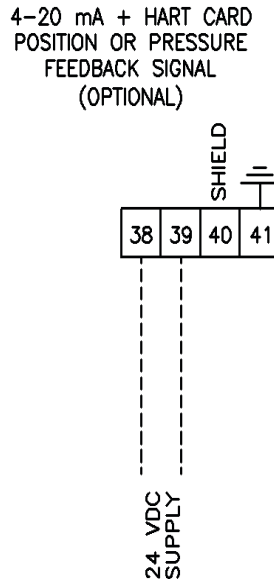

The HART Card is optional.

9.2.9.1 Modbus Card – Wiring Diagram

Figure 27

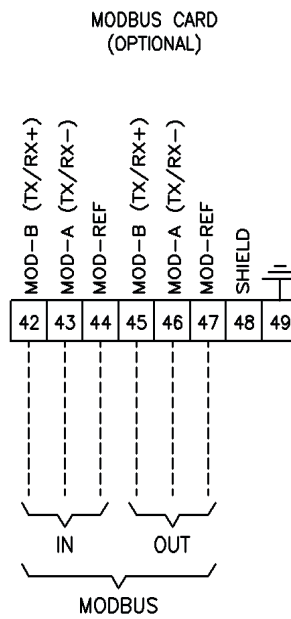

Section 10: INSTALLATION – START-UP

If ordered as part of an actuator, the factory mounts the IMVS2000v2 device on the actuator, makes pneumatic connections to the actuator, sets up and calibrates the instrument.

If IMVS2000v2 device is purchased separately, you will need a mounting kit to mount the device on the actuator. See the following instructions (also attached to the mounting kit) for detailed information on mounting the IMVS2000v2 device to a specific actuator model.

⚠ WARNING

The IMVS2000v2 is not provided with specific means for lifting and transporting. Manually move the IMVS2000v2 according to the effective rules of health and safety of the installation country.

⚠ WARNING

It is assumed that the installation, the setting, the commissioning, the maintenance and repair works are carried out by qualified personnel and checked by responsible Specialists.

⚠ WARNING

The end user shall provide circuit-breakers and fuses in the marshalling cabinet of the control room, to switch off the Mains and any other voltage applied to the IMVS2000v2 cabinet. Before opening the door of the IMVS2000v2 cabinet it is mandatory to check that any voltage (Mains or Control Voltages) is off. Breakers, fuses, differential breakers, in general any disconnecting device:

- Shall be in accordance with the local national standards and plant rules.
- Shall be sized to be in accordance to the maximum power accepted by the IMVS2000v2 interface.
- Shall be suitable located and easily reached.
- Shall be marked as the disconnecting device for the equipment.
- Shall not interrupt the protective earth conductor.

⚠ WARNING

Avoid personal injury or property damage from sudden release of process pressure or bursting of parts. Before proceeding with any Installation procedures:

- Always wear protective clothing, gloves, and eyewear to prevent personal injury.
- Personal injury or property damage may result from fire or explosion if natural gas is used as the supply medium and preventive measures are not taken. Preventive measures may include: enough ventilation around the unit, re-evaluating the hazardous area classification, ensuring adequate ventilation, and the removal of any ignition sources.
- Check with your process or safety engineer for any additional measures that must be taken to protect against process media.

Important

The installation must be carried out in accordance to the applicable standards IEC/EN 60079-14 and IEC/EN 60079-17 regarding the electrical installations in Hazardous Areas (other than mines) classified as Zones 1, 2 (gas) and Zones 21, 22 (dust) following IEC/EN 60079-10-1 and IEC/EN 60079-10-2 and any other applicable national standards and rules.

10.1 Installation in ambient with explosive dusts

Important

The installation and maintenance must be carried out in accordance with EN 61241-14 and IEC 61214-14.

Special attention to these following points:

- before the assembly the joint surfaces must be greased with Aeroshell grease.
- the cable glands must have a protection degree at minimum IP66/68 (EN/IEC 60529).
- periodically verify the quantity of dust deposited on the enclosure and clean it in the case the quantity becoming more than 5 mm.

10.2 Checks to be performed before installation

WARNING

Before the installation it is mandatory to check if the nameplate associated to the extension for additional entry specifies the appropriate degree of protection and ambient temperature limits as requested by the Rules applicable to the plant/location where units are installed.

If the IMVS2000v2 device is purchased separately, please proceed as follows before its installation:

1. The electrical supply cables must be suitable for the power rating (see the certificates delivered with the IMVS2000v2, if available, or the IMVS2000v2 nameplate);
2. Gather the necessary tools for the assembly and setting of the IMVS2000v2 controls;
3. Check that the coupling dimensions of the actuator flange and stem meet the IMVS2000v2 coupling dimensions;
4. Clean the actuator flange and remove anything that might prevent a perfect adherence to the IMVS2000v2 flange and especially all traces of grease.

If a long storage period has occurred, before installing the IMVS2000v2, please:

1. Check the status of the O-ring seals;
2. Check the installation of the plugs or cable glands on the cable entries;
3. Check whether the enclosure covers of the IMVS2000v2 body are cracked or broken.

10.3 Preliminary operations

1. Setting the actuator position
 - in case of single acting actuator (spring return), set the actuator at the end of the stroke (closed or open position) by removing the supply pressure;
 - in case of double acting actuator, set the actuator at the end of the stroke (closed or open position).
2. Move the IMVS2000v2 device to the actuator's corresponding position, set in step 1), by rotating the position shaft (please refer to the picture below).

Figure 28

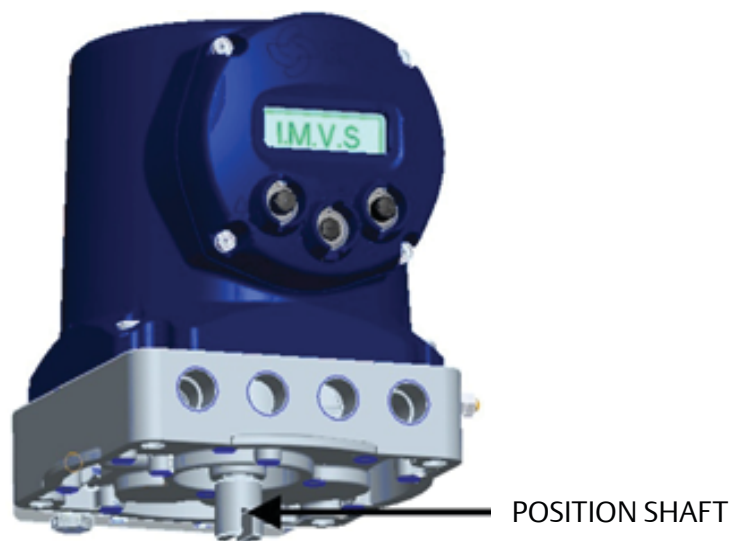

The IMVS2000v2 position is shown by the orientation of the indicator arrow in the upper window (in the pictures below are shown the CLOSED and OPEN position).

Figure 29

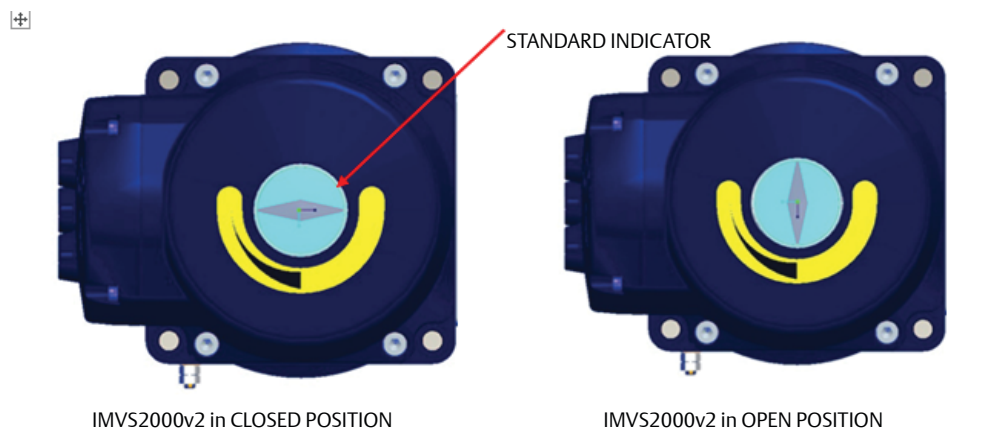

10.4 Mechanical Connections

10.4.1 Mounting IMVS2000v2 onto RP/RPS type actuators

Figure 30

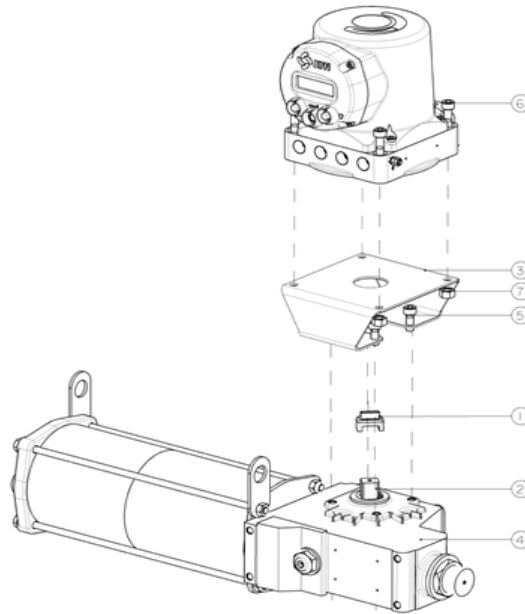

Referring to the picture above, perform the following steps:

- Assemble the joint (1) onto the actuator shaft (2);
- Assemble the bracket (3) onto the actuator carter (4) by tightening the 4 screws (5): (the bracket orientation is shown in the picture);
- Assemble the IMVS2000v2 device onto the bracket, checking carefully that the female part of the IMVS2000v2 position shaft is mounted correctly onto the male part of actuator joint (2);
- Tighten the 4 screws (6) and nuts (7) in order to fix the IMVS2000v2 device onto the bracket; and
- The picture below shows the IMVS2000v2 device assembled onto the actuator.

Figure 31

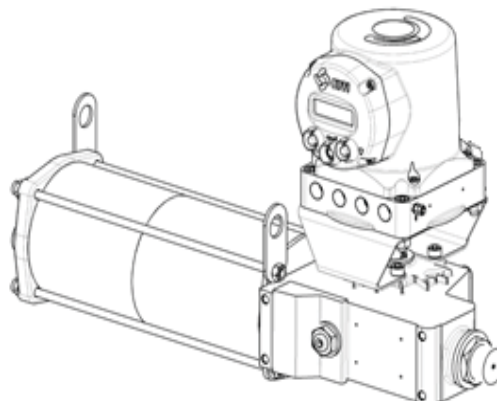

10.4.2 Mounting IMVS2000v2 onto ALGA/ALGAS type actuators

Figure 32

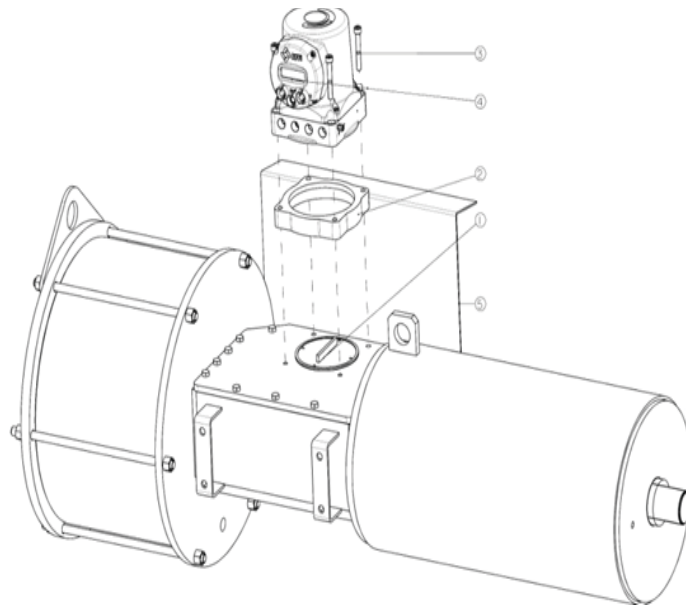

Referring to the picture above, perform the following steps:

- Put the spacer (2) onto the actuator carter;
- Assemble the IMVS2000v2 device onto the spacer, checking carefully that the female part of the IMVS2000v2 position shaft is mounted correctly onto the male part of actuator joint (1). The IMVS2000v2 device must be oriented as shown in the picture: the IMVS2000v2 display (4) is opposite to the actuator control panel (5); and
- Tighten the 4 screws (3) in order to fix the IMVS IMVS2000v2 device and the spacer on to the actuator.

The picture below shows the IMVS2000v2 device assembled onto the actuator.

Figure 33

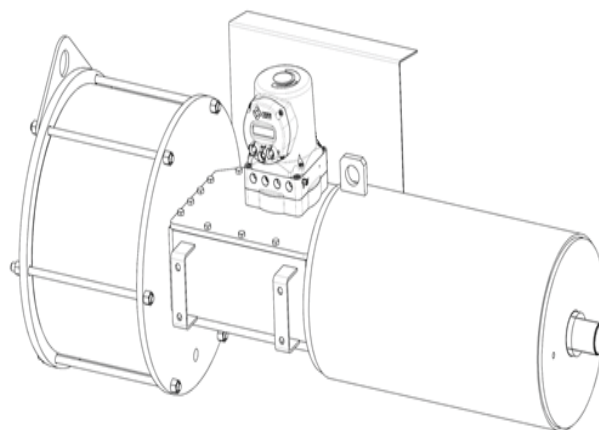

10.5 Pressure Connections

Figure 34

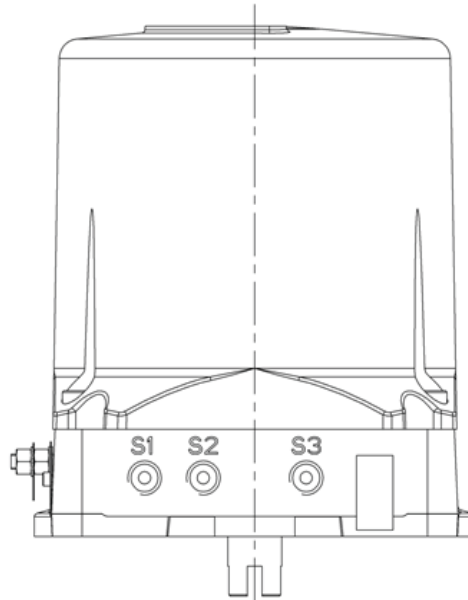

IMVS2000v2 Pressure Connections

- S1, S2: connections to the actuator cylinder active chamber/chambers (S1 for single acting actuators, S2 for double acting actuators).
- S3: connection to the process.

10.6 Cables and Electrical Connections

10.6.1 Cables Connection

The sealing of cables and/or conduit entries must be carried out in accordance with National Standards or the Regulatory Authorities that have certified the IMVS2000v2. Method of sealing and cable glands must be approved and separately certified for use in hazardous areas.

The ELBS-20 enclosure must be connected to the EARTH through the External EARTH stud.

Figure 35

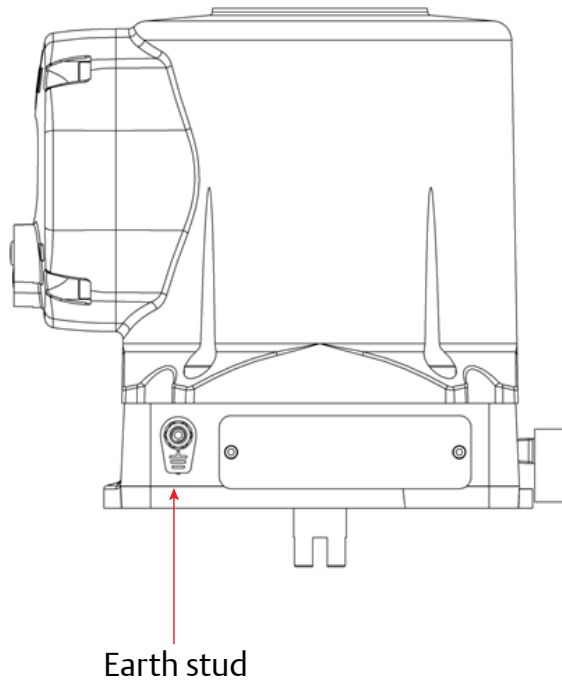

Earth Stud Position

Important:

- to prevent any water infiltration through the line cable conduits, be sure the cable glands used have the minimum degree of protection required by the plant.
- if rigid conduits make the connection, we suggest placing a flexible pipe connection between the conduit and the terminal board.

To guarantee weatherproof and explosionproof fit, screw the cable glands tightly (at least 5 turns) and block them with a thread sealant. The use of a thread sealant is necessary in case of explosionproof capability.

If some parts of the cable glands have been removed during work on the cable entries put them back into place now to avoid losing the dismantled parts.

Important:

The cables **MUST** be selected considering the maximum Temperature of the cable indicated on the label fixed to the IMVS2000v2 Enclosure.

Connect the external wires in accordance with the wiring diagram attached to the documentation of IMVS2000v2. For details about the signals connection see 9.

10.6.2 Removing the electrical enclosure's covers

⚠ WARNING

If the device is located in a hazardous area, a Specific permit defined by Countries must be obtained before opening the explosion proof enclosures. Moreover, the area must be cleaned from explosive mixture since batteries and power supply could generate electrical spark and cause explosion.

⚠ WARNING

The flameproof joints are not intended to be repaired but where necessary the original manufacturer shall be contacted for guidance and information on the dimensions of the flameproof joints.

⚠ WARNING

The user shall be aware that all external fasteners on which the flameproof enclosure depends are stainless steel socket head cap screws class A4 -grade 70.

⚠ WARNING

During the opening and closing the IMVS2000v2 units, pay attention not to damage the joint surface of the covers and of the base manifold.

⚠ WARNING

Follow the procedure below for removing the covers. Using a different disassembly sequence can damage the internal parts of the device (e.g. electronic cards and cables).

Important:

In case the screws of the cover need to be replaced a Stainless Steel Class A4 grade 70 with minimum yield strength of 450 N/mm² must be used.

Figure 36



1. Using a 4 mm Allen key, loosen the four screws fixing the local interface cover and remove it. At the end of wiring connections replace the cover and fix the 4 screws with a tightening torque from 4 to 5 Nm.

Figure 37

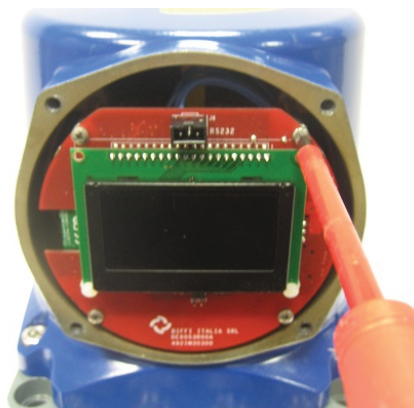

2. Using a screw driver, loosen the four screws fixing the LCD card and remove it.

Figure 38

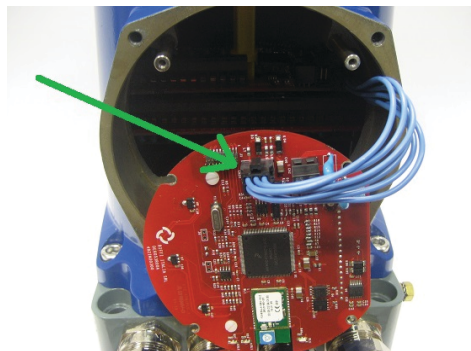

3. Disconnect the cable on the Display Card.

Figure 39



4. Using a 6 mm Allen key, loosen the four screws fixing the cover and remove it. At the end of wiring connections replace the cover and fix the 4 screws with a tightening torque from 15 to 20 Nm.

10.6.3 Unused entries

⚠ WARNING

Replace the plastic plugs, install present at the unused entries certified explosion-proof plugs and block with a thread sealant to guarantee the tightening. Not performing the above recommendation will invalidate the safety protection in case of presence of hazardous atmospheres.

10.6.4 Cables requirements – EMC protection

The table below summarizes the specifications of the cables, for connecting with the IMVS2000v2. Particularly, it indicates if a cable needs to be armoured or shielded.

“Shielded” must be considered as a stricter condition than “Armoured.”

”It is possible to use a shielded cable instead of a required armoured cable, but it is not possible to use an armoured cable instead of a required shielded cable.

Table 13.

CONNECTION TYPE	CABLES REQUIREMENT (Armoured or Shielded)
Main Supply	None
SISA – SISB	Max Length 3 mt.
SOV A – SOV B	None
Digital Input	None
Digital Output	None
MODBUS	Shielded (see [3] for details).
HART – 4-20mA Analogue Output	Shielded. Maximum Load (cable + termination resistance) = 300 ohm. See [2] for details

10.6.5 Wires dimensions

Before making any connection with the IMVS2000v2, check the electrical parameters present (voltage and current limits) on the nameplate and in this manual.

Max dimension of the wires: 2.5 mm².

The dimension of the wires must respect the current regulations of the installation country.

10.7 Commissioning Procedure

⚠ WARNING

If the device is located in a hazardous area, a “hot permit” must be obtained before opening the explosion proof enclosures. Moreover, the area must be cleaned from explosive mixture since batteries and power supply could generate an electrical spark and cause an explosion.

The first thing to be done during the commissioning is to correctly configure the IMVS2000v2.

For performing the commission procedure, the IMVS2000v2 must be able to open and close the valve/actuator.

Before starting any of the below mentioned command, wait for stabilization of the pressures and position.

It is suggested to perform Calibration and Signatures by starting from the “normal” working position of the actuator/valve; it guarantees a better diagnostic.

The Commissioning Procedure consists in five operations:

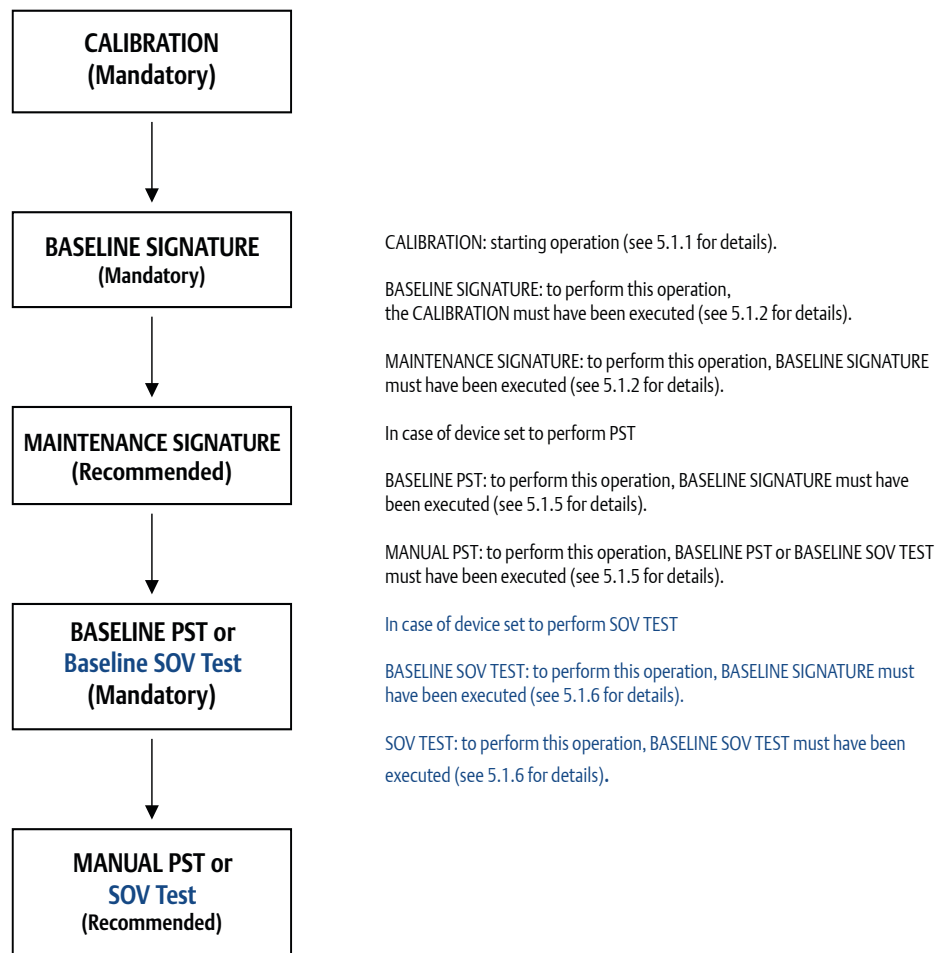

Section 11: Parts List

This section includes the drawings and the parts' list of the General Assembly and of the Spare Parts of the ELBS-20.

Important:

This section includes the drawings and the parts' list of the General Assembly and of the Spare Parts of the ELBS-20.

Important:

When ordering spare parts, please refer to the marked parts' list items on the attached drawings.

11.1 General Assembly

Figure 40

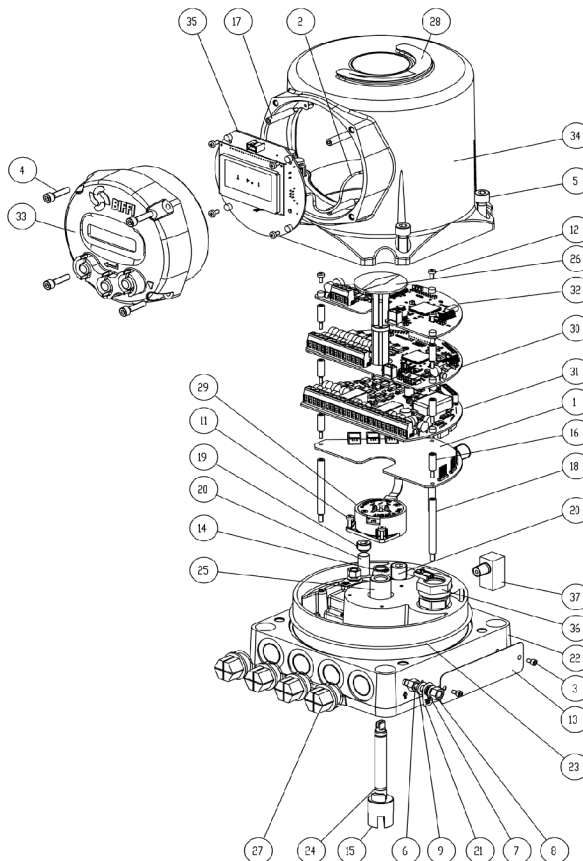

NOTES:

- (*): 9 if bus card is present otherwise 6.
- (**): it depends on the ordering code
- (***): it is an optional card

Table 14.

Pos.	Description	Qty.
1	BARRIER CARD	1
2	LOGIC-DISPLAY CABLE	1
3	SCREW UNI 5931 M3x6 A4-70	2
4	SCREW UNI 5931 M5x22 A4-70	4
5	SCREW UNI 5931 M8x25 A4-70	4
6	LOGIC CARD	1
7	BEAD UNI 5923 M6x25 AISI 304	2
8	ANTI-LOOSENING WASHER UNI 8842-J6	2
9	NUT M6 UNI 5587 SS316 h6 Ch10	4
10	WASHER 6.4x2x1.6 UNI6592 AISI 316	2
11	SCREW PZ TYPE M3x10 7687 AISI 316	3
12	SCREW PZ TYPE M3x6 7687 AISI 316	7
13	LABEL – NAMEPLATE	1
14	RETAINING RING FOR SHAFT D.10 UNI7435	1
15	POSITION SHAFT AISI 316	1
16	SPACER M/F M3 H16 AISI 316	9(*)
17	SPACER M/F M3 H30.5 AISI 316	4
18	SPACER M/F M4/M3 H56 AISI 316	3
19	RING NUT M12 AISI 316	1
20	SINTERED METAL DISK AISI 316	1
21	PLUG 1/4"NPT	0-3 (**)
22	EARTH NAMEPLATE	1
23	BASE MANIFOLD	1
24	O-RING D=6.86 W=1.78 FLR	1
25	O-RING D=145.72 W=2.62 FLR	1
26	BUSHING FOR POSITION SHAFT	1
27	POSITION INDICATOR	1
28	PLUG M20 EP435 /M20x1.5 - OTM	4
29	POSITION LABEL	1
30	POSITION SENSOR ASSEMBLY	1
31	RELIEF BLOCK	1
32	BASE POWER CARD	1
33	BUS CARD (OPTIONAL)	1 (***)
34	COVER ASM FOR LOCAL DISPLAY	1
35	BASE COVER WITH WINDOW ASM	1
36	DISPLAY CARD	1
37	IMVS2000v2 PRESSURE SENSOR	0-3 (**)

11.2 Spare Parts

Figure 41

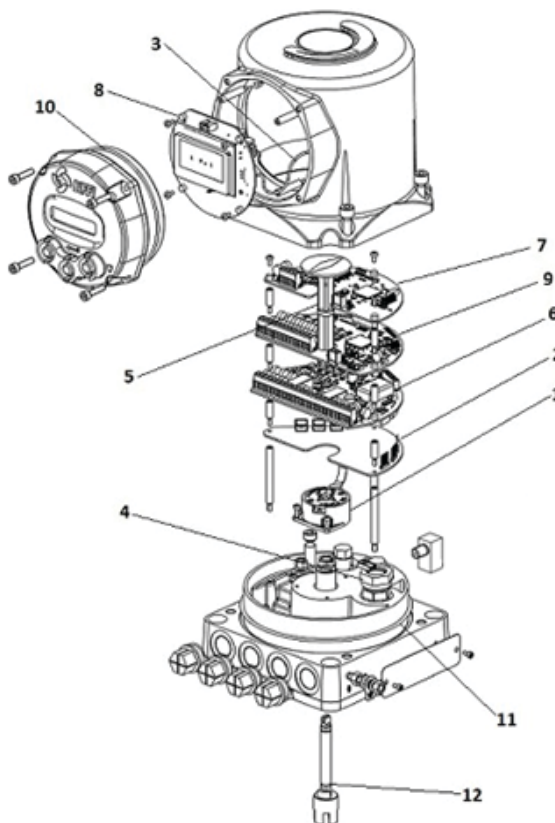

Table 15.

Pos.	Description	Code	Qty.
1	POSITION SENSOR ASSEMBLY	4400000011	1
2	BARRIER CARD	492BAR1000	1
3	LOGIC-DISPLAY CABLE	492IMVSCB1	1
4	IMVS2000v2 PRESSURE SENSOR	434IMV1000 (10 bar) 434IMV2000 (100 bar) 434IMV3000 (200 bar) 434IMV5000 (400 bar)	0-3
5	POSITION INDICATOR	3340030110	1
6	BASE POWER CARD	492IM30100	1
7	BUS CARD (OPTIONAL)	492IM30400 (HART) 492IM30500 (MODBUS)	1
8	DISPLAY CARD	492IM30300	1
9	LOGIC CARD	492IM30200	1
10	O-RING D=101.32 W=1.78 FLR	8102045000	1
11	O-RING D=145.72 W=2.62 FLR	8102162000	1
12	O-RING D=6.86 W=1.78 FLR	8105052000	1

Section 12: Decommissioning

Figure 42 Disposal and recycling



At the end of the life of IMVS2000v2, the device must be disassembled.

⚠ WARNING

Do not dump non-biodegradable products, lubricants and non-ferrous (rubber, PVC, resins, etc.) into the environment. Dispose of all such materials as indicated in the following table:

Table 16.

Subject	Hazardous	Recyclable	Disposal
Electrical and electronic equipment	Yes	Yes	Use specialist recyclers.
Glass	No	Yes	Use specialist recyclers.
Metals	No	Yes	Use licensed recyclers.
Plastics	No	Yes	Use specialist recyclers.
Rubber (seals and o-rings)	Yes	No	May require special treatment before disposal, use specialist waste disposal companies.
Battery Cells	Yes	No	May require special treatment before disposal, use specialist waste disposal companies.

⚠ WARNING

Do not re-use parts or components which appear to be in good condition after they have been checked or replaced by qualified personnel and declared unsuitable for use.

Important:

In all cases check local authority regulation before disposal.

Section 13: Trouble Shooting

⚠ WARNING

If the device is located in hazardous area a "hot permit" must be obtained before opening the explosion proof enclosures. Moreover, the area must be cleaned from explosive mixture since batteries and power supply could generate electrical spark and cause explosion.

⚠ WARNING

During the opening and closing the IMVS2000v2 units, pay attention do not damage the joint surface of the covers.

Table 17.

#	Detected problem	Actions to be performed
1	THE IMVS DOES NOT SWITCH ON WHEN POWERED	<ul style="list-style-type: none"> verify the Main Supply on terminals 3 & 4. verify that the wiring is correct. verify the Display Card cable is connected.
2	THE IMVS DOES NOT WORK FROM LOCAL CONTROLS	<ul style="list-style-type: none"> verify the integrity of the Display Card cable. Device already connected to Biffi Assistant.
3	THE IMVS CAN NOT MOVE THE ACTUATOR	<ul style="list-style-type: none"> verify the wiring is correct. verify the pneumatic or hydraulic connections. verify the supply on terminals 5-6 and 12-13 (if connected). verify the supply pressure of the actuator.
4	NO OUTPUT VOLTAGE TO THE SOLENOID VALVE(S)	<ul style="list-style-type: none"> verify that the wiring is correct. verify the supply on terminals 5-6 and 12-13 (if connected). verify that the voltage on terminals 8-9-10 and 16-17-18 respects the polarity (\pm). verify that available power (Watts) of power supply source is correctly sized.
5	THE LOCAL POSITION INDICATOR IS NOT CONSISTENT WITH ADHESIVE LABEL	<ul style="list-style-type: none"> remove the base cover (see 10). remove the position indicator (just pull the item to disassembly from the position sensor). rotate the position indicator 90 degrees. install again the cover and tighten the screws.
6	THE IMVS DOES NOT IDENTIFY CORRECT TRAVEL LIMITS OR ACTUATOR POSITION	<ul style="list-style-type: none"> perform a Calibration. verify the mechanical coupling of the IMVS to the actuator: no clearance must exist.
7	THE IMVS GETS NO PRESSURE INDICATION	<ul style="list-style-type: none"> verify the tubing between IMVS and actuator. verify the supply pressure of the actuator.
8	THE IMVS CAN NOT PERFORM THE BASELINE PST	<ul style="list-style-type: none"> verify the Main Supply on terminals 3 & 4. verify that the wiring is correct. verify the supply on terminals 5-6 and 12-13. (if connected) verify that the voltage on terminals 8-9-10 and 16-17-18 respects the polarity. (\pm) verify that "Base. S. St." = "Passed." verify that "PST En." = "Yes."
8	THE IMVS CAN NOT PERFORM THE BASELINE SIGNATURE	<ul style="list-style-type: none"> verify the Main Supply on terminals 3 & 4. verify that the wiring is correct. verify the supply on terminals 5-6 and 12-13. (if connected) verify that the voltage on terminals 8-9-10 and 16-17-18 respects the polarity. (\pm) verify the pneumatic or hydraulic connections. verify the supply pressure of the actuator. verify that "Cal. Status" = "Passed." verify that "Sign. En." = "Yes."

Table 18.

#	Detected problem	Actions to be performed
9	THE IMVS CAN NOT PERFORM THE MAINTENANCE SIGNATURE	<ul style="list-style-type: none"> • verify the Main Supply on terminals 3 & 4. • verify that the wiring is correct. • verify the supply on terminals 5-6 and 12-13. (if connected) • verify that the voltage on terminals 8-9-10 and 16-17-18 respects the polarity. (\pm) • verify the pneumatic or hydraulic connections. • verify the supply pressure of the actuator. • verify that "Base. S. St." = "Passed." • verify that "Sign. En." = "Yes."
10	THE IMVS CAN NOT PERFORM THE CALIBRATION	<ul style="list-style-type: none"> • verify the Main Supply on terminals 3 & 4. • verify that the wiring is correct. • verify the supply on terminals 5-6 and 12-13. (if connected) • verify that the voltage on terminals 8-9-10 and 16-17-18 respects the polarity. (\pm) • verify the pneumatic or hydraulic connections. • verify the supply pressure of the actuator. • verify that "Cal. Enabled" = "Yes."
11	THE "COMMON FAILURE ALARM" DO IS NOT CONSISTENT WITH THE "CFA St."	<ul style="list-style-type: none"> • verify that the wiring is correct. (terminals 29-30) • verify the setting of "CFA Mode."
12	THE "PST IN PROGRESS" DOES NOT WORK CORRECTLY	<ul style="list-style-type: none"> • verify that the wiring is correct. (terminals 31-32)
13	THE "PST PASSED" DO NOT WORK CORRECTLY	<ul style="list-style-type: none"> • verify that the wiring is correct. (terminals 33-34)
14	THE "PST FAILED" DO NOT WORK CORRECTLY	<ul style="list-style-type: none"> • verify that the wiring is correct. (terminals 35-36)
15	PROBLEM WITH BLUETOOTH COMMUNICATION	<ul style="list-style-type: none"> • verify that "Blue. En" = "Yes."
16	PROBLEM WITH RS232 COMMUNICATION	<ul style="list-style-type: none"> • verify the integrity of the RS232 cable.
17	THE DEVICE GETS A WRONG PRESSURE INDICATION	<ul style="list-style-type: none"> • Verify the consistency of the parameters dealing with the Pressure Sensors.
18	PROBLEM WITH BUS COMMUNICATION	See [2] and [3].

Section 14: Ordering Table

234IMV	X1	X2	X3	X4	X5	X6	X7	X8
<p>0) Product Identification (6 Digits)</p> <p>1) Pressure Sensors configuration (1 Digit) 0 = Sensors [S1] and [S2] not installed A = Single sensor [S1] 10 barg (145 psig) (*) B = Double sensors [S1]+[S2] 10 barg (145 psig) (*) C = Single sensor [S1] 100 barg (1450 psig) D = Double sensors [S1]+[S2] 100 barg (1450 psig) E = Single sensor [S1] 200 barg (2900 psig) F = Double sensors [S1]+[S2] 200 barg (2900 psig) G = Single sensor [S1] 400 barg (5800 psig) (**) H = Double sensors [S1]+[S2] 400 barg (5800 psig) (**)</p> <p>2) Configuration / Wiring Diagram (1 Digit) A = Configuration A B = Configuration B C = Configuration C D = Configuration D E = Configuration E F = Configuration F G = Configuration G H = Configuration H</p> <p>3) Bus/Interface Cards (1 Digit) 0 = Without bus/interface cards 1 = HART + 4-20mA Output Interface 2 = MODBUS Interface 3 = HART + 4-20mA Output Interface – IMVS2000 replacement (***)</p> <p>4) Material (1 Digit) 0 = Full enclosure in SS 316L 1 = Full enclosure in SS 316L + anticorrosive paint (*)</p> <p>5) Beacon® indicator (1 Digit) 0 = Standard indicator (see 10.3) 1 = Black/Yellow Beacon® indicator 2 = Red/Green Beacon® indicator</p> <p>6) Additional pressure sensor scale (1 Digit) 0 = Sensor [S3] not installed 1 = Sensor [S3] 10 barg (145 psig) (*) 2 = Sensor [S3] 100 barg (1450 psig) 3 = Sensor [S3] 200 barg (2900 psig) 4 = Sensor [S3] 400 barg (5800 psig) (**)</p> <p>7) Certification (1 Digit) 0 = ATEX/IECEX (with Standard Indicator: II 2GD Exd IIC T4, with Beacon® Indicator: II 2GD Exd IIB T4) IP66/68 and NEMA 4, 4X & 6 1 = CCOE - IP66/68 and NEMA 4, 4X & 6 2 = EAC - IP66/68 and NEMA 4, 4X & 6 3 = INMETRO - IP66/68 and NEMA 4, 4X & 6 4 = CSA: see paragraph 2.5.1 5 = CSAus: see paragraph 2.5.1</p> <p>8) Shaft (1 Digit) B = Shaft Standard Biffi N = Shaft Namur Type</p>								

Note: mounting KIT, when required, must be ordered separately by specifying the type of actuator (rotary or linear) and dimension of the interface.

- (*) Consult Factory for availability.
- (**) Consult Factory for applications over 345 barg.
- (***) Option to be used only to replace an IMVS2000 device.

Section 15: Document Revision

Table 19.

Rev.	Date	Description	Prepared	Approved
0	03/10/2014	First Issue	Battaglia	Comelli
1	08/11/2016	Second Issue	Battaglia	Comelli
2	11/11/2016	Third Issue	Battaglia	Comelli
3	04/10/2018	Fourth Issue	Battaglia	Vigliano
4	11/02/2019	Fifth Issue	Piacenti	Battaglia
5	13/03/2019	Sixth Issue	Piacenti	Battaglia
6	07/10/2019	Seventh Issue	Piacenti	Franco

Biffi Italia s.r.l.
Strada Biffi 165
29017 Fiorenzuola d'Arda (PC)
Italy
T +39 0523 944 411

For complete list of sales and manufacturing sites, please visit
www.biffi.it or contact us at biffi_italia@biffi.it

©2019 Biffi. All rights reserved.

The contents of this publication are presented for information purposes only, and while every effort has been made to ensure their accuracy, they are not to be construed as warranties or guarantees, express or implied, regarding the products or services described herein or their use or applicability. All sales are governed by our terms and conditions, which are available on request. We reserve the right to modify or improve the designs or specifications of our products at any time without notice.

