

Biffi ICON3000

Profibus DPV1 Module



Revision Details

Rev.	Date	Description	Prepared	Approved
8	April 2022	Update to the ICON3000v2	F.P.	C.D.
7	November 2021	General update (Migration to new template)		
6	August 2017	Added Note for Base card FW 7.00	F.P.	C.D.
5	October 2015	Added EDD, DTM and Redundancy application note references	F.P.	C.D.
4	October 2009	Updated Profibus certification valid for life	C.D.	A.A.
3	May 2009	Added explanations to diagnostics data structure and other minor changes	C.D.	A.A.
2	May 2005	Added CERTIFICATION document	C.D.	A.A.
1	November 2004	Reviewed Usr_Prm string and Slot/Index assignment	C.D.	A.A.
0	October 2004	Instruction for rev. 4.0 Profibus DPV1 Interface	C.D.	A.A.

Table of Contents

Section 1: Introduction

Introduction	1
--------------------	---

Section 2: Operation and Storage

Operation and Storage.....	2
----------------------------	---

Section 3: Communication Features

Communication Features.....	3
-----------------------------	---

Section 4: ICON2000v4_DPV1 Module

4.1 On Board Indication	4
4.2 On Board Indication for ICON3000v2 Actuator	5

Section 5: Profibus DP Description

Profibus DP Description	6
-------------------------------	---

Section 6: RS485 Transmission Mode

RS485 Transmission Mode	7
-------------------------------	---

Section 7: Slave Redundancy

Slave Redundancy	9
------------------------	---

Section 8: Wiring and Bus Terminations

8.1 Redundant Channel.....	11
8.2 Single Channel	14
8.3 Single Channel Zero Stub	15

Section 9: ICON2000v4_DPV1 Power-Up

ICON2000v4_DPV1 Power-Up	17
--------------------------------	----

Section 10: Data Exchanged During Parameterization

Data Exchanged During Parameterization	18
--	----

Section 11: Data Exchange Mode

11.1	Cyclic Communications DPV0	21
11.1.1	Output Data	21
11.1.2	Input Data	22
11.1.3	Diagnosis Message	24
11.2	Acyclic Communication DPV1	29
11.2.1	Nameplate	29
11.2.2	General Data	30
11.2.3	Maintenance Information	30
11.2.4	Alarm and Warning Log	32
11.2.5	Maintenance Commands.....	33

Section 12: Data at Local Operator Interface

12.1	Bus Control	34
12.2	Node Report	36
12.3	Bus Signal Failure Indication	38

Section 1: Introduction

The ICON2000v4_DPV1 is an electronic card that allows connecting the Biffi electrical actuator ICON3000 actuators to a Profibus DP network. The card has its microprocessor and a program stored internally. It works as a pure bus interface and does not affect the actuator control integrity. It is installed inside the actuator housing and takes the electrical power from the actuator power supply card. The RS485 interface is located on the card board. The Profibus network is fully isolated from the actuator electronics.

The ICON2000v4_DPV1 is designed to support Profibus redundant communication.

The ICON2000v4_DPV1 module can also be installed in the ICON3000v2 actuator.

The ICON3000v2 actuator can be recognized because when it is switched on, the name "ICON3000v2" appears on the local screen, as shown in Figure 1.

Figure 1



Section 2: Operation and Storage

The module is designed to work and to be stored in the same environment of the actuator.

Section 3: Communication Features

Communication protocol	: Profibus DP according to EN 50170
Network topology	: Line (bus) structure. With repeaters tree structures can also be realized
Transmission medium	: Twisted, screened copper cable according to EN 50170
Data rate	: 9.6 19.2 45.45 93.75 187.5 500 1500 Kbit/s
Cable length without repeater	: 1200 1200 1200 1200 1000 400 200 m
Station type	: DPV0 and DPV1 slave
Device number	: 32 devices per segment without repeater (max 126, with repeaters)
Bus access	: Token-passing between masters and polling for slaves
Electrical power	: Actuator powered (as option: auxiliary external voltage supply)
Bus termination	: Configurable on board via local operator interface of actuator
Temperature	: -40 °C, +85 °C
Fieldbus redundancy	: Two independent communication interfaces
Types of operation	: Cyclic data exchange, Sync mode, Freeze mode, Fail-safe mode
Baud rate	: Automatic recognition
Addressing	: Configurable via local operator interface

Section 4: ICON2000v4_DPV1 Module

The module consists in a single PCB that is installed inside the actuator housing. It is connected to the ICON3000 base card via strip connector. The internal wiring connects the Profibus data lines to the actuator terminal board.

Figure 2 ICON2000v4_DPV1 module for ICON3000 actuator

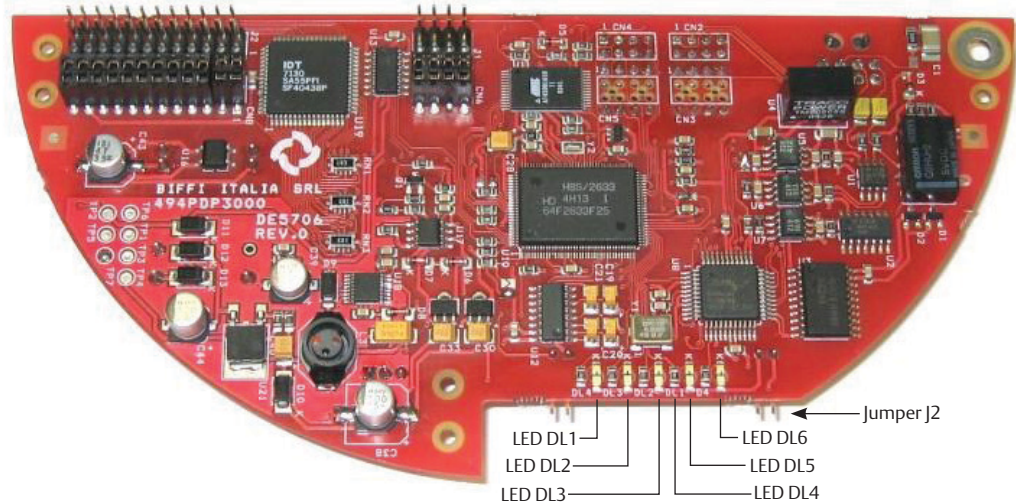

4.1 On Board Indication

Five LEDs are mounted on the ICON2000v4_DPV1 to give the following indications for Field service. LEDs indications are active only when jumper JP2 is closed.

- | | |
|----------------------------|--|
| DL1 (Red) Data Area Empty: | ON when Data Area on interface card is not loaded.
BLINK when Data Area is being read from base card.
OFF when Data Area is completely loaded. |
| DL2 (Red) Base comm: | ON when the communication between the base card and the interface is not working properly.
OFF when the communication between the base card and the interface is correct. |
| DL3 (Orange) Slave State: | ON when the interface acts as an Primary Slave (i.e. it is the interface with a valid communication with the Master).
BLINK when the interface acts as a Backup Slave and it is ready (only for redundant configuration).
OFF when the interface is not communicating with any Master. |
| DL4 (Green) Termination: | ON when the on board Profibus termination has been inserted.
OFF when the on board Profibus termination has not been inserted. |
| DL5 (Green) Profibus: | ON when Profibus communication has been established and the interface has entered in DATA_EX state. |
| DL6 (Green) Power: | ON when the interface is correctly powered. |

More indications are given on local operator interface as described in Section 12.2, Node Report.

4.2 On Board Indication for ICON3000v2 Actuator

Figure 3 ICON2000v4_DPV1 module for ICON3000v2 actuator

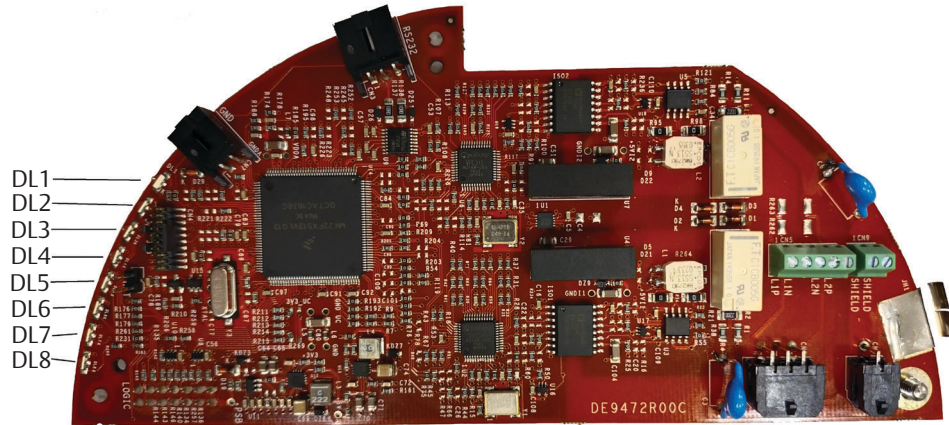

Eight LEDs are mounted on the PRO2000v4_RED to give the following indications for Field service.

- DL1 (Red) Alarm active: ON when the interface detects one or more hardware issue.
OFF when the interface can work correctly.
 - DL2 (Orange) Slave state primary: ON when the IM1 interface module acts as Primary Slave (i.e., it is the interface with a valid communication with the Master).
BLINK when the IM1 interface module acts as a Backup Slave and it is ready.
OFF when the IM1 interface module is not communicating with any Master.
 - DL3 (Green) Slave State: BLINK when the interface communicates with base card.
Fixed ON or OFF when the communication between base card and interface is locked.
 - DL4 (Green) Profibus: ON when Profibus communication of IM1 has been established and the interface has entered in DATA_EX state.
 - DL5 (Orange) Slave state primary: ON when the IM2 interface module acts as Primary Slave (i.e., it is the interface with a valid communication with the Master).
BLINK when the IM2 interface module acts as a Backup Slave and it is ready.
OFF when the IM2 interface module is not communicating with any Master.
 - DL6 (Green) Application running: BLINK when the interface application is running correctly.
Fixed ON or OFF when the application is not running correctly.
 - DL7 (Green) Profibus: ON when Profibus communication of IM2 has been established and the interface has entered in DATA_EX state.
 - DL8 (Green) Power On: ON when interface module is correctly powered from base card.
- More indications are given on local operator interface as described in Section 12.2, Node Report.

Section 5: Profibus DP Description

Profibus is a vendor-independent, open field bus standard used in a wide range of application in process automation. Vendor independence and openness are ensured by the international standards EN 50170 and EN 50254. The DP communication profile is designed for data exchange at the field level. The central controllers (as PLC) communicate via serial connection with field devices (as sensors and actuators). Data exchange is mainly cyclic. The central controller (called Master) cyclically reads the input information from the field devices (called Slaves) and cyclically writes the output information to the slaves. In addition, Profibus DP provides communication services for parameterization, alarm handling and monitoring of intelligent field devices. The maximum number of Master and Slave devices in a bus segment is 32 without repeaters. With repeaters, the number can be extended to 126. The maximum cable length depends on the speed of transmission. Higher is the speed, shorter is the length. For instance, with baud rate 93.75 kb/s, the max cable length is 1,200 m without repeaters.

Mono-master or multi-master system configuration can be provided. Bus access is controlled by token passing procedure between masters and master-slave procedure (polling) between master and slaves.

Types of devices:

DP Master Class 1 (DPM 1):	This is the central controller that cyclically exchange information with the field devices. Typical devices are PLC or PC.
DP Master Class 2 (DPM 2):	These devices are necessary for commissioning, maintenance and diagnostics.
Slave:	Field device such transmitters, actuators, drives, etc.

Figure 4 shows a Profibus DP configuration with two Master devices and different Slave devices.

Figure 4

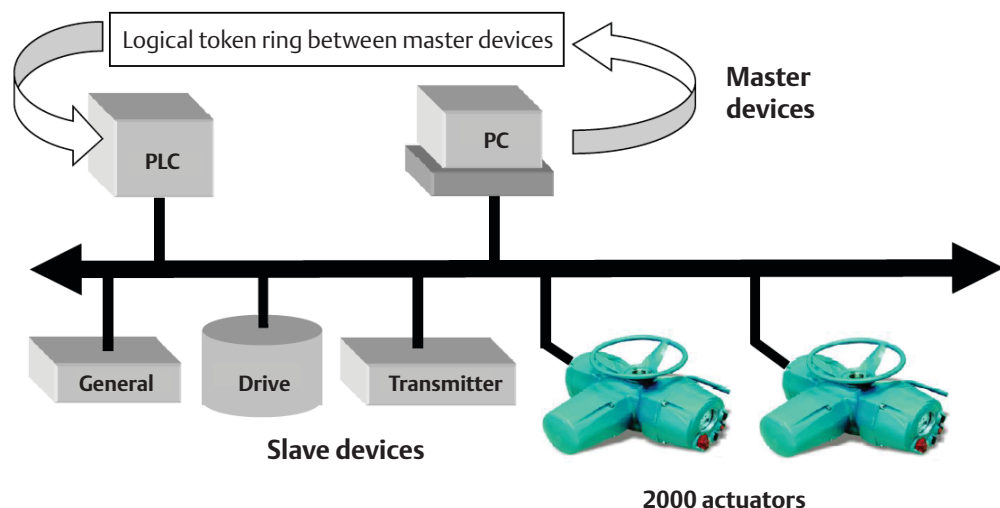

Section 6: RS485 Transmission Mode

The ICON2000v4_DPV1 module uses a half duplex, multidrop, serial communication line RS485. The module communicates with the Masters via its RS485 interface and the transmission media consists in a shielded twisted pair cable. Transmission speed from 9.6 kbit/s to 1.5 Mbit/s are available. One unique transmission speed is allowed for all devices on the bus when the system works.

All devices are connected in a bus structure. Up to 32 station (Master and Slaves) can be connected in one segment without repeaters. Repeaters can be used to extend the number of device up to 126 and to enlarge the network area. Table 1 shows the relationship between baud rate and segment length.

Table 1.

Baud Rate	Maximum segment length (no repeater)
9.6 K	1200 m
19.2 K	1200 m
45.45 K	1200 m
93.75 K	1000 m
187.5 K	1000 m
500 K	400 m
1500 K	200 m

The bus must be terminated by an active bus terminator at the beginning and at the end of each segment. Only two terminations in one bus segment must be provided. To ensure error-free operation, both bus terminators must be powered. The maximum cable length depends on the transmission speed. Cable lengths indicated in Table 1 are based on type A cable, as specified by the EN 50170, having the following characteristics.

- Impedance from 135 to 165 ohm
- Capacity < 30 pF/m
- Loop resistance 110 ohm/km
- Wire gauge 0.64 mm
- Conductor area > 0.34 mm²

The use of cable of previously used type B is not recommended.

The data lines must not be reversed. Use of shielded cable is mandatory for having high system immunity against electromagnetic disturbs. The shield should be connected to ground on both sides. The data lines should be kept separate from all other cables. It should be laid in separate, conductive and earthed cable trunking. It must be ensured that there are no voltage difference between individual nodes of Profibus DP.

Figure 5

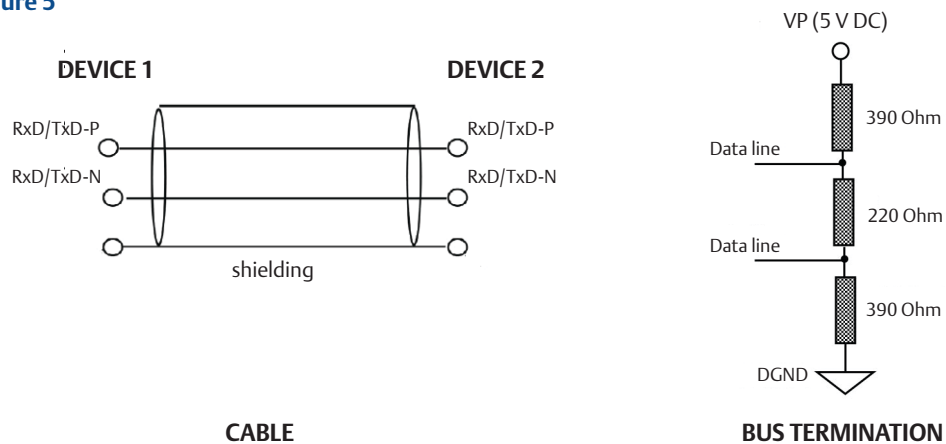
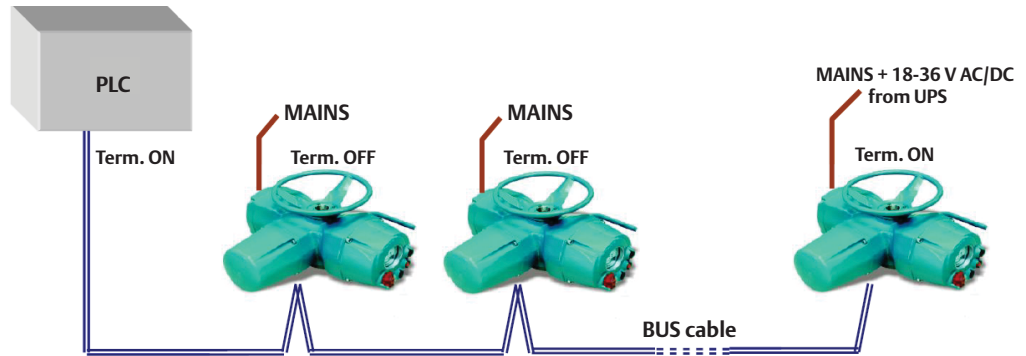

Figure 6 below shows the bus with an actuator at the end of the bus segment. Ensure that the terminations are supplied. Also, if the mains fails, an auxiliary voltage supply generated by an UPS is connected to the actuator to supply the electronics and the termination.

Figure 6



Section 7: Slave Redundancy

The ICON2000v4_DPV1 is designed to allow the actuator to act as a redundant slave as described in this section, additional information about Slave Redundancy of ICON2000v4_DPV1 are described on “DTDE443 Redundancy Operation Description”, and “MDE236 Integration of ICON3000 in Redundant S7-400H System”.

Redundancy functionality may be requested when ordering the actuator; in this way, the actuator is equipped with a full redundant communication. The schematic of the redundant slave is as follows:

Figure 7

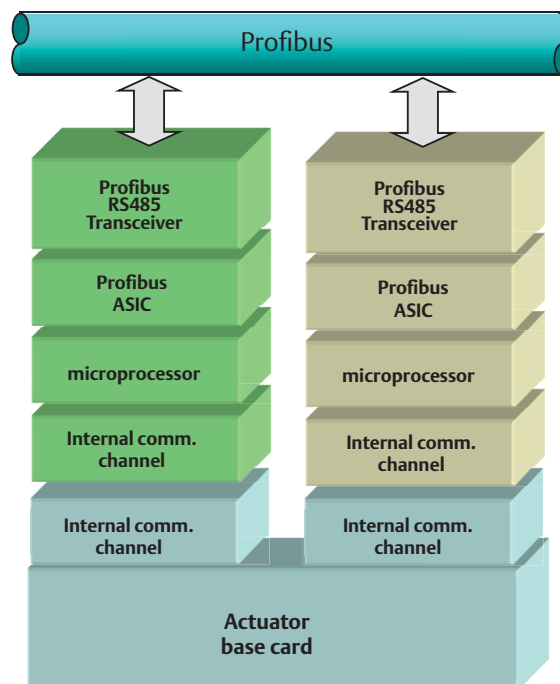

The two interfaces are indicated as Primary Slave and Backup Slave. The following simple rules define the redundancy strategy:

- An internal arbitration defines the role of the interfaces during the start-up.
- The base card tries first to establish a valid communication with the Primary Slave.
- There is always just one Slave (Primary or Backup) with a valid communication with the Profibus line. It is indicated Active Slave.
- Both Slaves can answer to Profibus interrogation: only the Active Slave has valid data and this condition is indicated by a specific bit in the cyclic communication.
- Both Slaves receive the commands from Master but the base card can execute only the commands from the Active Slave.
- When the Primary Slave stops to work or its interface does not sense any Profibus communication, the base card enables the Backup Slave that becomes Active.
- After the Primary Slave fails, the Profibus communication continues via the current Active Slave. A maintenance service is necessary to restore the Primary Slave.
- The Profibus slave addresses are assigned for each interface from the Local Operator Interface of the actuator and the addressing is depending on the redundant system structures that has been selected.

Figure 8

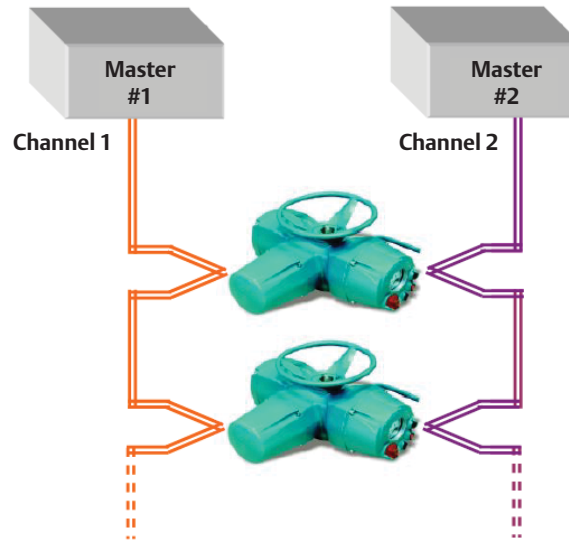

In this layout, the two interfaces may have the same address because the two interfaces are on different channels. A synchronization method must be active between the Master stations to take the information from the Active Slave.

Figure 9

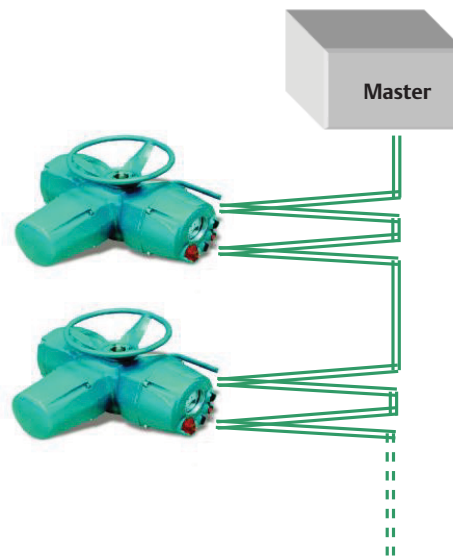

In this layout, the two interfaces shall have different addresses because the two interfaces are on the same channel.

The very flexible redundancy strategy implemented in the ICON2000v4_DPV1 module allows also different layout that the Master station can drive. The bus terminations can be switched on each data lines by means of two links, configurable via local operator interface.

Section 8: Wiring and Bus Terminations

The very flexible strategy implemented in the ICON2000v4_DPV1 card allows also different layout that the Master station can drive. The bus terminations can be switched on each data lines by means of two links configurable via local operator interface.

The ICON2000v4_DPV1 card takes its electrical supply from the actuator power supply card. The RS485 bus transceiver is isolated from the actuator electronics. Also, the voltage supply of the bus termination is isolated. The ICON2000v4_DPV1 card is equipped with on-board bus termination that should be used when the actuator is at the beginning or at the end of the bus segment and if there is no external termination. The bus termination can be switched on the data lines by means of a link, configurable via local operator interface.

Since the bus termination is a crucial component to ensure error-free operation, it is important that termination remains powered also when the actuator supply has left. If the internal termination is used, it is suggested to connect to the actuator also an auxiliary 18 V AC/36 V DC generated by safe source that will supply just the actuator electronics and the Profibus termination. Hence, in order to avoid Profibus connection loss if the actuator is switched off, it must be present an internal DC/DC converter option not included in the normal supply for the actuator, to be specified upon purchase order.

8.1 Redundant Channel

Figures 10 and 11 show the wiring necessary in case single channel zero stub slave. The termination must be linked to the data lines only if the actuator is at the beginning or at the end of the bus segment. The redundant channel feature must be requested when ordering the actuator.

Figure 10 Wiring connection for ICON3000/ICON2000v4 and F01 actuator

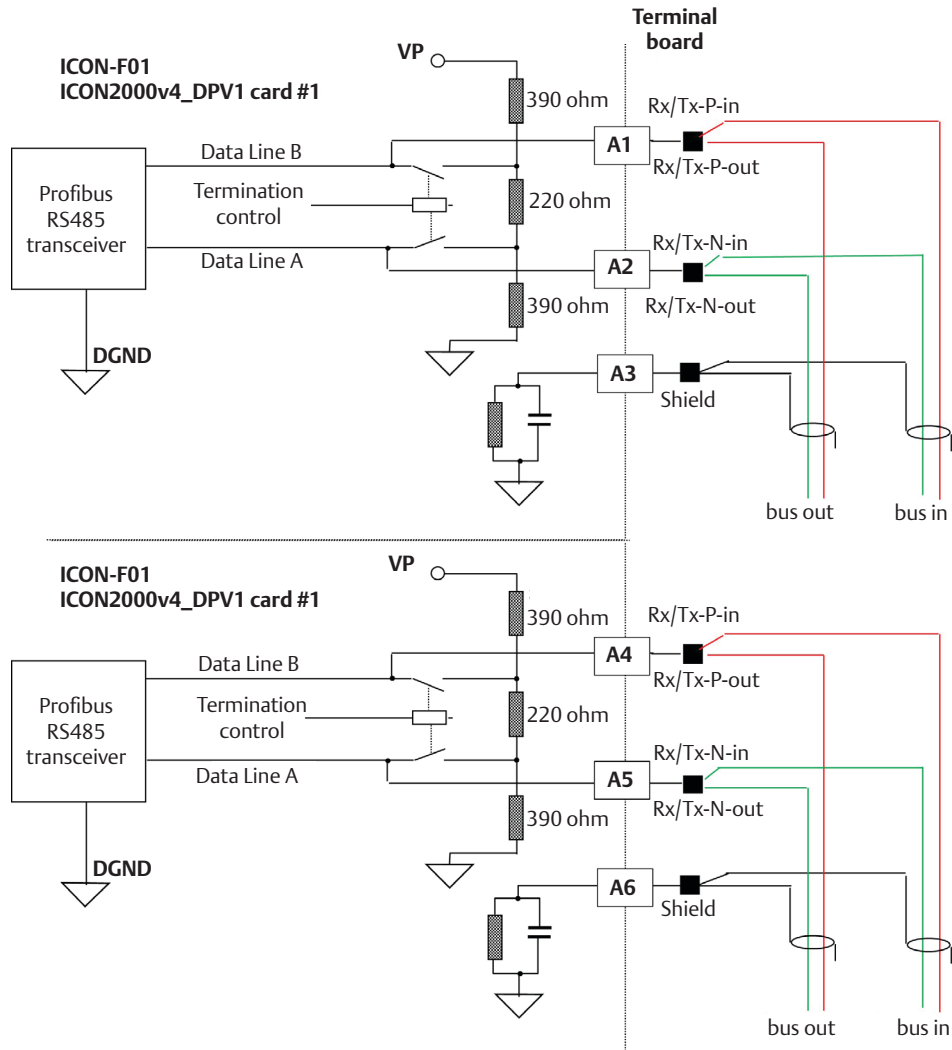
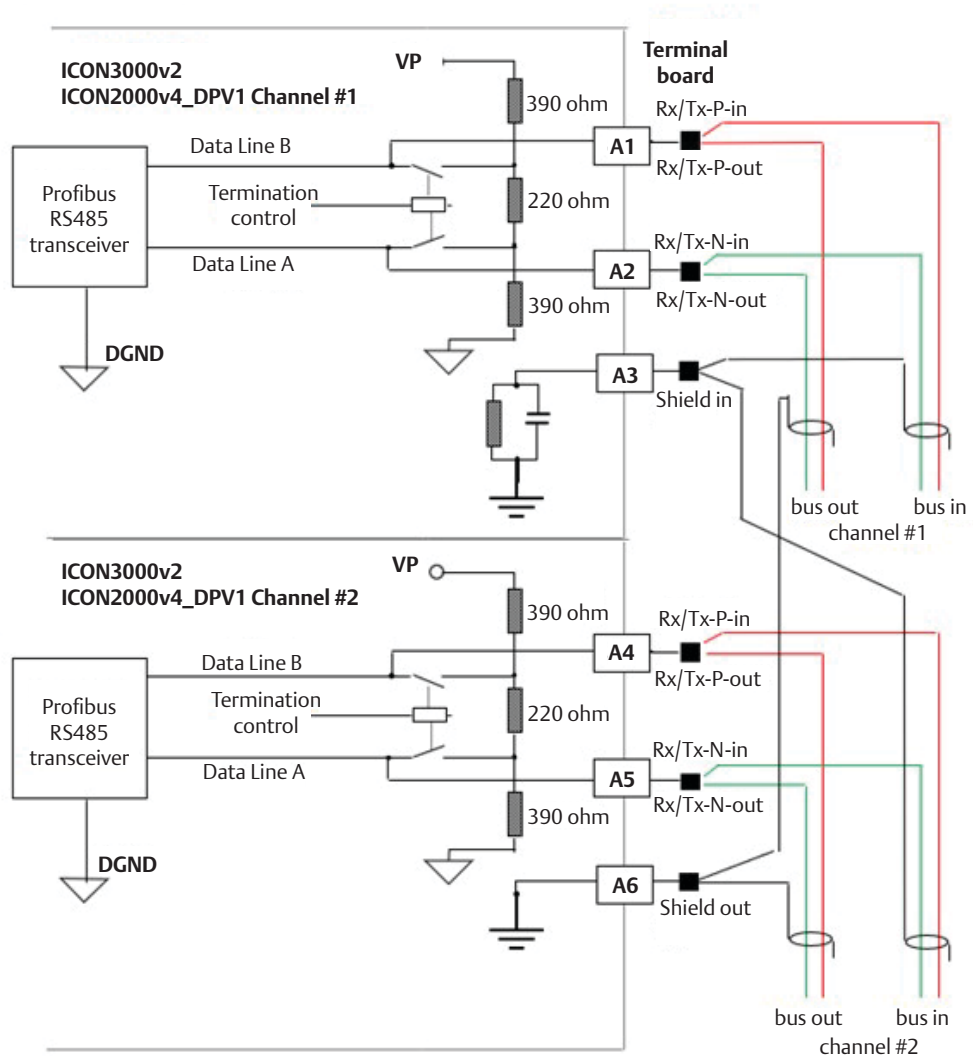

Figure 11 Wiring connection for ICON3000v2 actuator



8.2 Single Channel

Figures 12 and 13 show the wiring necessary in case single channel slave. The termination must be linked to the data lines only if the actuator is at the beginning or at the end of the bus segment.

Figure 12 Wiring connection for ICON3000/ICON2000v4 and F01 actuator

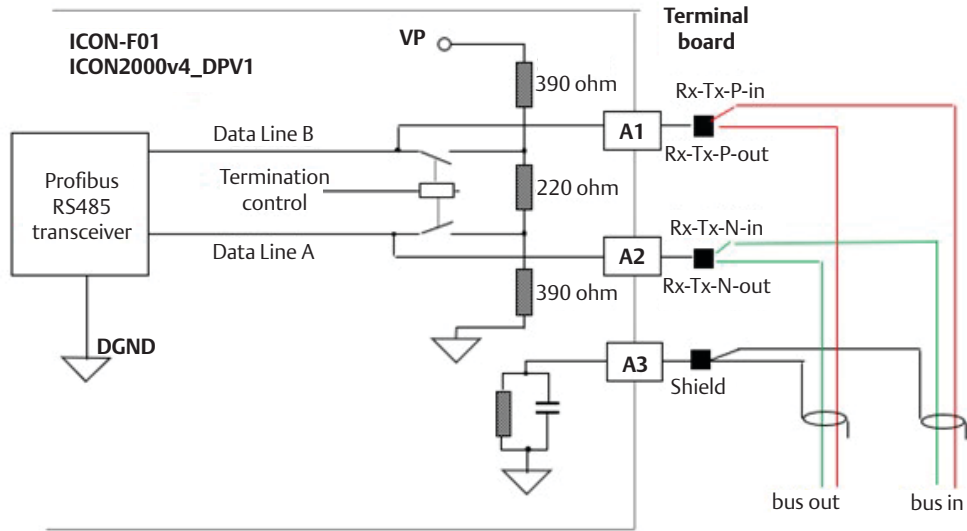
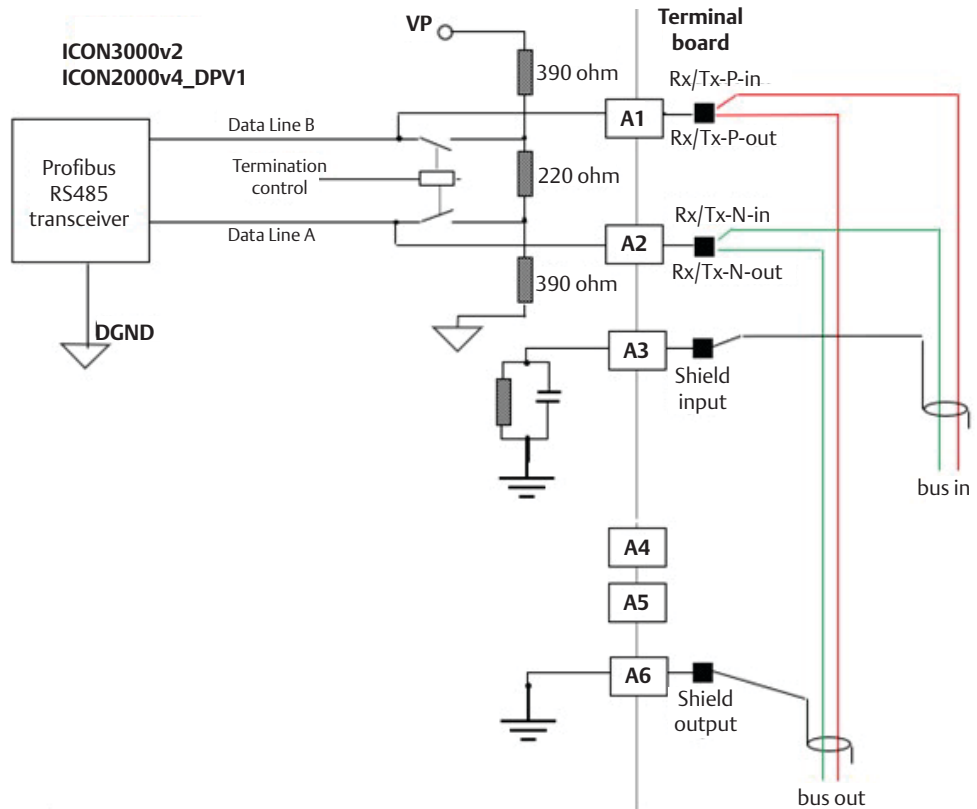

Figure 13 Wiring connection for ICON3000v2 actuator



8.3 Single Channel Zero Stub

Figures 14 and 15 show the wiring necessary in case single channel zero stub slave. The termination must be linked to the data lines only if the actuator is at the beginning or at the end of the bus segment. The single slave “zero stub” feature must be requested when ordering the actuator.

Figure 14 Wiring connection for ICON3000/ICON2000v4 and F01 actuator

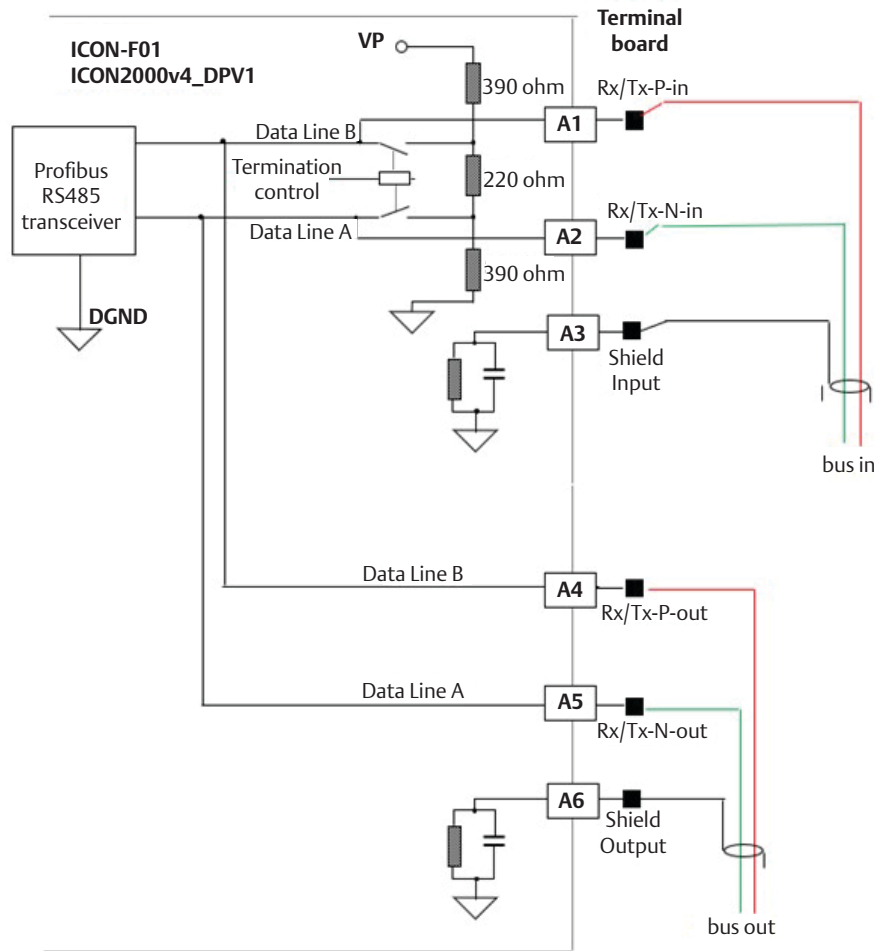
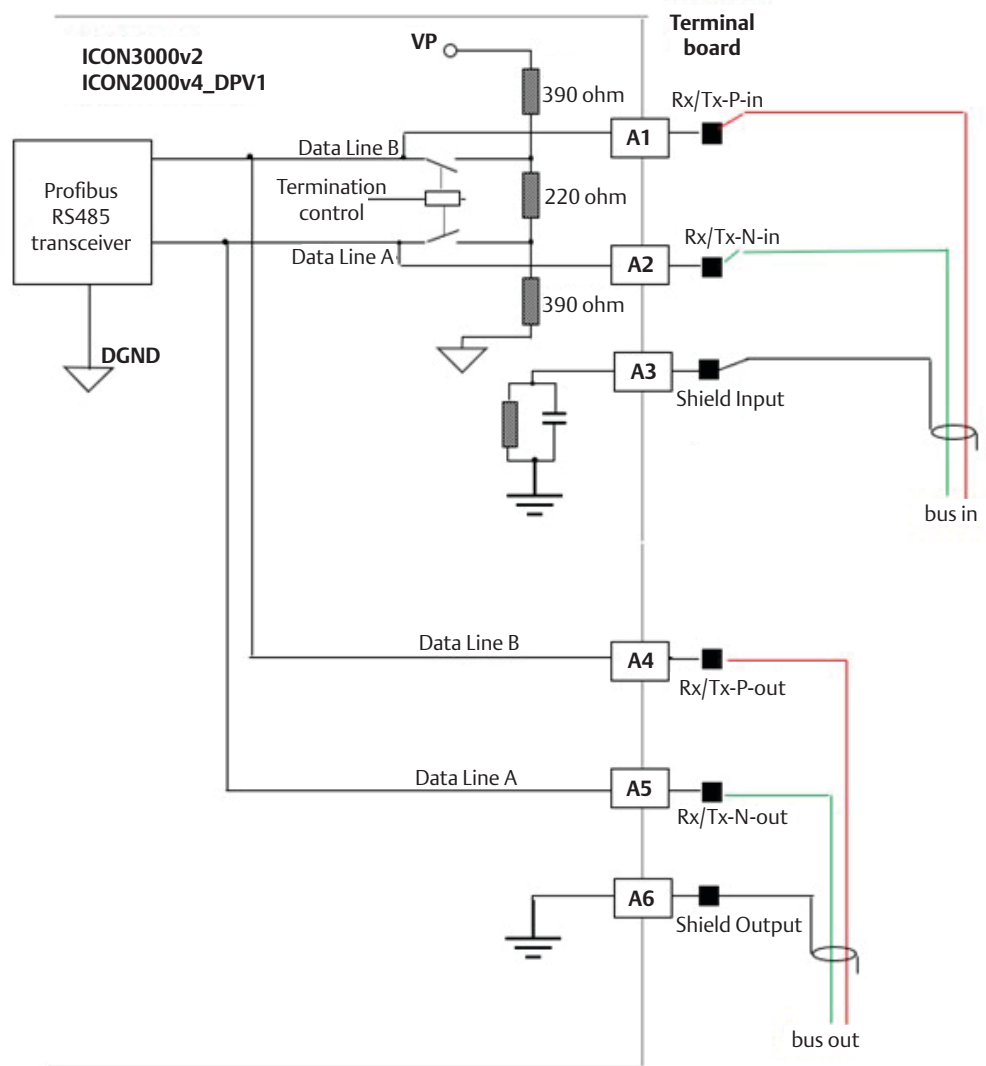

Figure 15 Wiring connection for ICON3000v2 actuator



Section 9: ICON2000v4_DPV1 Power-Up

On power-up, the module checks the baud rate and then it waits for the “parameterization” telegram from the Master. The parameterization message contains user information needed for actuator operation and listed in the Section 10: “Data Exchanged During Parameterization”.

After that, the module waits for the “configuration” telegram from Master. The configuration message contains the number of input and output bytes reserved in the memory of the Master device for each slave. Only the number of bytes determined in the configuration is transmitted between Master and Slave. This information is called “module”. The ICON2000v4_DPV1 board implements the following modules:

- Module 1: 1 byte output; 2 bytes input
- Module 2: 4 byte output; 8 bytes input
- Module 3: 1 byte output; 2 bytes input - **Consistent**
- Module 4: 4 byte output; 8 bytes input - **Consistent**

Consistent is an attribute that specify the capability of the module to maintains data consistency over the entire data length. In this way, the data will not change during the reading by the Profibus DP-Master. For example, if module 2 is selected, the output telegram consists in 4 bytes and the input telegram in 8 bytes.

When parameters and configuration are correct, the module enters in “data exchange mode” and starts with normal operation. The Master cyclically sends commands to the Slave and read its status. Figure 10 shows the state machine of a DP slave:

Figure 16

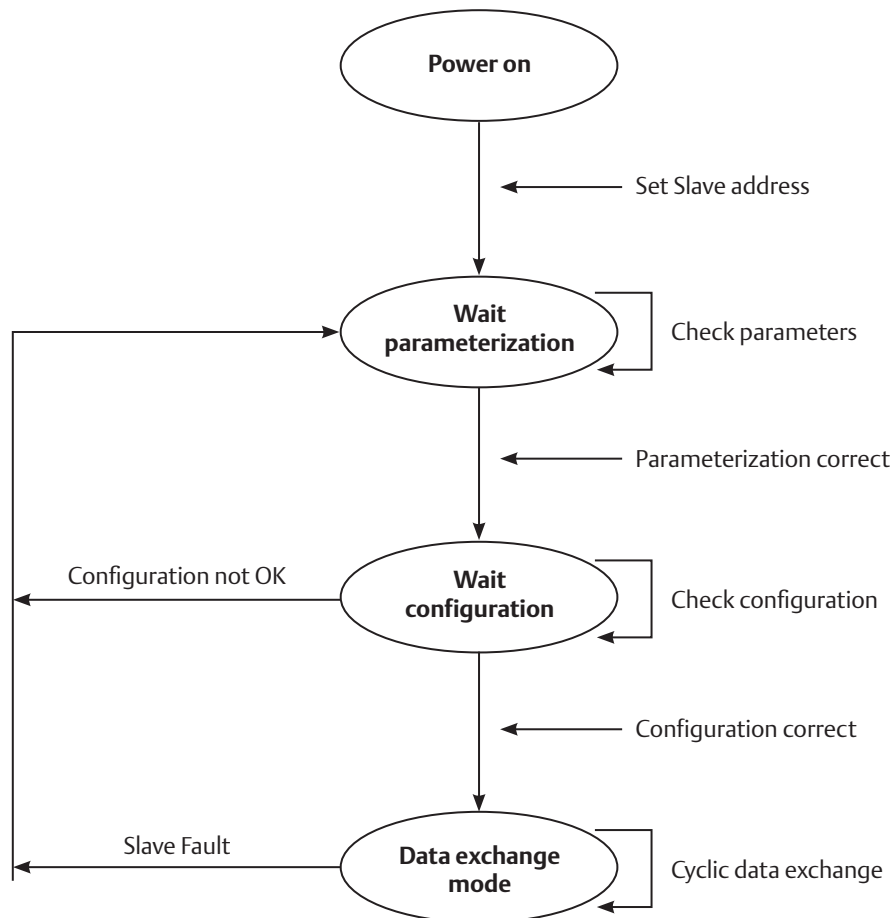

Section 10: Data Exchanged During Parameterization

The following data are sent to the ICON2000v4_DPV1 interface:

Table 2.

Byte	Name	Type	Range	Default	EU
0	Reserved DP V1	1 byte	-	-	-
1	Reserved DP V1	1 byte	-	-	-
2	Reserved DP V1	1 byte	-	-	-
3	Storage Format	1 byte	0	LSB first	LSB first
			1		MSB first
4	Fail-safe Action	1 byte	0	Off	Off
			1		Close
			2		Open
			3		Stayput
			4		Go to position
5	Delay before initiating safe operation	1 byte	0-255	4	seconds
6	Safe Position	1 byte	0-100	50	%
7	Timer Open direction – status	1 byte	0	Off	Off
			1		On
8	Timer Open direction – on time	1 byte	2-200	2	seconds
9	Timer Open direction – off time	1 byte	1-200	2	seconds
10	Timer Open direction – start position	1 byte	0-100	0	%
11	Timer Open direction – stop position	1 byte	0-100	100	%
12	Timer Close direction – status	1 byte	0	Off	Off
			1		On
13	Timer Close direction – on time	1 byte	2-200	2	sec
14	Timer Close direction – off time	1 byte	1-200	2	sec
15	Timer Close direction – start position	1 byte	0-100	100	%
16	Timer Close direction – stop position	1 byte	0-100	0	%
17	Reserved	1 byte	-	-	-
18	Dead band	1 byte	1-255	10	tenth of %
19	Motion inhibit	1 byte	1-255	6	seconds

It should be noted that every time the Profibus communication is established, the parameterization string will be sent to the device, writing the parameters to the set up values. The values in parameterization string shall be modified at the Master station.

Byte 0-2 Reserved for DPV1

Byte 3 Storage format

It defines the format of the variables that are transmitted on 2 or 4 bytes. The setting of this parameter affects the format of the following data:

- Output Data (if Module 2 is selected)
Position Request
- Input Data (if Module 2 is selected)
Actuator Position, Output Torque
- General Maintenance Info
Slot 2 Index 0
Actuator Position, Output Torque, Opening Time, Closing Time, Contactor Cycles, Motor Run Time, Time Without Power, Utilization Rate
- Recent Maintenance Info
Slot 2 Index 1
Recent Contactor Cycles, Recent Motor Run Time, Recent Time Without Power, Recent Utilization Rate
- Value
0: LSB byte is transmitted first (default setting)
1: MSB byte is transmitted first

Byte 4	<p>Fail-safe action It defines the action of the actuator in case of loss of the bus signal. The action takes place only if the local selector is on REMOTE position and if the bus is operating. When the bus signal restores, the actuator also restores at its normal functioning.</p> <ul style="list-style-type: none"> — Value 0: Off - disable (default setting) 1: Close 2: Open 3: Stayput 4: Go to position indicated in the parameter 'Safe position'
Byte 5	<p>Delay before initiating fail-safe operation It defines the delay before execute the programmed Safe Action.</p> <ul style="list-style-type: none"> — Value minimum: 0 second maximum: 255 seconds default value: 4 seconds
Byte 6	<p>Safe position It defines the Safe position when 'Safe Action: go to position' is selected.</p> <ul style="list-style-type: none"> — Value minimum: 0 % maximum: 100% default value: 50%
Byte 7	<p>Timer Open Direction – Status It enables the Timer function in Open direction.</p> <ul style="list-style-type: none"> — Value 0: Off - disable (default setting) 1: On
Byte 8	<p>Timer Open Direction – On time It defines the On time of the Timer function in opening.</p> <ul style="list-style-type: none"> — Value minimum: 2 seconds maximum: 200 seconds default value: 2 seconds
Byte 9	<p>Timer Open Direction – Off time It defines the Off time of the Timer function in opening.</p> <ul style="list-style-type: none"> — Value minimum: 1 second maximum: 200 seconds default value: 2 seconds
Byte 10	<p>Timer Open Direction – Start position It defines the start position of the Timer function in opening.</p> <ul style="list-style-type: none"> — Value minimum: 0 % maximum: 100% default value: 0%
Byte 11	<p>Timer Open Direction – Stop position It defines the stop position of the Timer function in opening.</p> <ul style="list-style-type: none"> — Value minimum: 100 % maximum: 0% default value: 100%

Byte 12	<p>Timer Close Direction – Status It enables the Timer function in close direction.</p> <ul style="list-style-type: none"> — Value 0: Off - disable (default setting) 1: On
Byte 13	<p>Timer Close Direction – On time It defines the On time of the Timer function in closing.</p> <ul style="list-style-type: none"> — Value minimum: 2 seconds maximum: 200 seconds default value: 2 seconds
Byte 14	<p>Timer Close Direction – Off time It defines the Off time of the Timer function in closing.</p> <ul style="list-style-type: none"> — Value minimum: 1 second maximum: 200 seconds default value: 2 seconds
Byte 15	<p>Timer Close Direction – Start position It defines the start position of the Timer function in closing.</p> <ul style="list-style-type: none"> — Value minimum: 100 % maximum: 0% default value: 100%
Byte 16	<p>Timer Close Direction – Stop position It defines the stop position of the Timer function in closing.</p> <ul style="list-style-type: none"> — Value minimum: 0 % maximum: 100% default value: 0%
Byte 17	<p>Reserved</p>
Byte 18	<p>Dead band It defines in tenth of % the Dead band of the positioning function available on the modulating actuator. The movement is inhibited until the difference between current position and requested position (position error) is lower than Dead band.</p> <ul style="list-style-type: none"> — Value minimum: 1 0.1% maximum: 255 22.5% default value: 10 1.0%
Byte 19	<p>Motion inhibit time It defines the minimum delay between two cycles of the motor when the actuator is in modulating service. It allows to adjust the number of start per hour of the electric motor.</p> <ul style="list-style-type: none"> — Value minimum: 1 second maximum: 255 seconds default value: 6 seconds

Section 11: Data Exchange Mode

The following paragraph describes the input and output messages of ICON2000v4_DPVI interface when working in “data exchange mode” for “cyclic data” and “acyclic data”. In all cases, it is called “input signal” a data flowing from actuator to bus, vice-versa it is called “output signal” a data flowing from bus to slave.

11.1 Cyclic Communications DPV0

11.1.1 Output Data

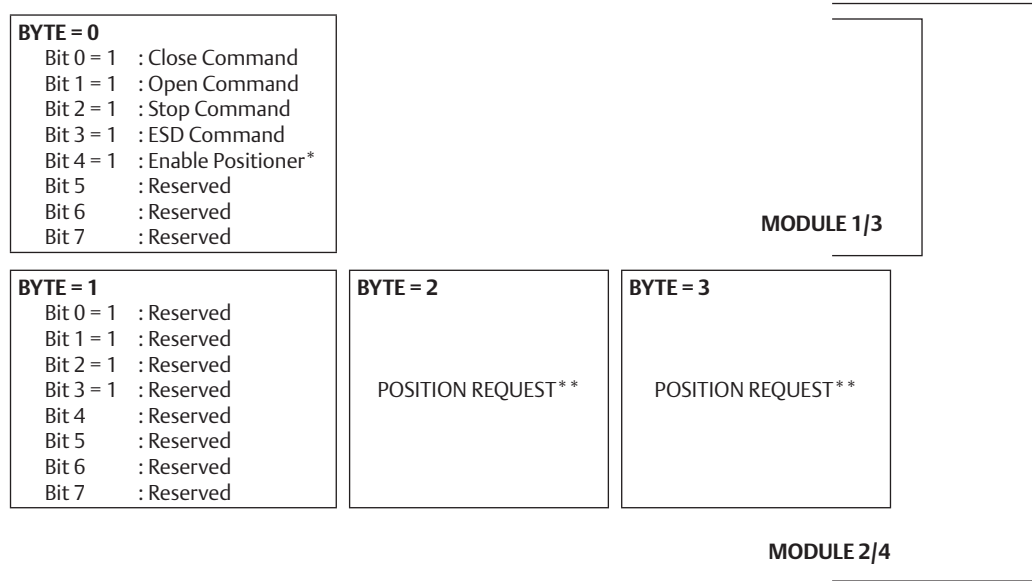

* In case of module 1: Reserved
 ** Position request: Integer 16 bits (value 0 = 0%; value 1000 = 100.0%)

11.1.2 Input Data

<p>BYTE = 0</p> <ul style="list-style-type: none"> Bit 0 = 1 : Close limit Bit 1 = 1 : Open limit Bit 2 = 1 : Closing Bit 3 = 1 : Opening Bit 4 = 1 : ESD active Bit 5 = 1 : Loc. Sel. on Remote Bit 6 = 1 : Loc. Sel. on Local Bit 7 = 1 : Loc. Sel. on Off 	<p>BYTE = 1</p> <ul style="list-style-type: none"> Bit 0 = 1 : Interlock open active Bit 1 = 1 : Interlock close active Bit 2 = 1 : Fail-safe action Bit 3 = 1 : Int. data updated* Bit 4 = 1 : Warning Bit 5 = 1 : Channel 1 active Bit 6 = 1 : Valid data** Bit 7 = 1 : Alarm 	MODULE 1 / 3
<p>BYTE = 2</p> <p style="text-align: center;">ACTUATOR POSITION §</p>	<p>BYTE = 3</p> <p style="text-align: center;">ACTUATOR POSITION §</p>	
<p>BYTE = 4</p> <ul style="list-style-type: none"> Bit 0 = 1 : Monitor relay Bit 1 = 1 : Motion inhibited Bit 2 = 1 : DIN 1 Bit 3 = 1 : DIN 2 Bit 4 = 1 : DIN 3 Bit 5 = 1 : DIN 4 Bit 6 = 1 : DIN 5 Bit 7 = 1 : DIN 6 	<p>BYTE = 5</p> <ul style="list-style-type: none"> Bit 0 = 1 : Aux_in_open Bit 1 = 1 : Aux_in_close Bit 2 = 1 : Aux_in_stop Bit 3 = 1 : Aux_in_bus-on Bit 4 = 1 : HW remote mode Bit 5 = 1 : Positioner mode Bit 6 : Reserved Bit 7 : Reserved 	
<p>BYTE = 6</p> <p style="text-align: center;">OUTPUT TORQUE §§</p>	<p>BYTE = 7</p> <p style="text-align: center;">OUTPUT TORQUE §§</p>	MODULE 2 / 4
<p>* "Internal data updated" is set to 1 when the Active Slave has updated its internal data area and the acyclic communications can read updated values.</p> <p>** "Valid data" is set to 1 when the Profibus interface is the Active Slave and the cyclic communications contains valid data.</p> <p>§ Position: Integer 16 bits (value 0 = 0%; value 1000 = 100.0%)</p> <p>§§ Torque: Integer 16 bits (OP: value 0 = 0%; value -100 = 100% - CL: value 0 = 0%; value +100 = 100%)</p>		

DIN setting

Via local operator interface of actuator, the DIN bits can be individually set to 1 if one of the conditions occurs:

- open limit	- remote selected	- valve jammed in OP
- closed limit	- local stop active	- valve jammed in CL
- position \geq xx%	- ESD signal on	- low battery (if present)
- position \leq xx%	- manual operation	- mid-travel alarm in OP or CL
- opening	- motor over-temperature	- EFS in manual
- motor running	- high-high torque	- PTS failed
- blinker	- high-high torque in OP	- MAINS (only as8)
- mid-travel position	- high-high torque in CL	- EFS coil OFF
- local selected	- valve jammed	- heater

The following settings are supplied by factory:

- DIN 1: mid-travel position
- DIN 2: local stop active
- DIN 3: motor over-temperature (motor thermostat alarm)
- DIN 4: over-torque (hi-hi torque alarm)
- DIN 5: valve jammed alarm
- DIN 6: mid-travel alarm in OP/CL

11.1.3 Diagnosis Message

The ICON2000v4_DP V1 interface manages the diagnosis indication coming from the actuator as stated by the Profibus DP V1 standard.

When the ICON2000v4_DP V1 interface needs to notify a fault to the master while in data exchange mode, it changes the function code in its response message to “high priority”. During the next regular bus cycle, the master in turn send a “Slave_Diag” request that is answered with a “Slave_Diag” response. The availability of ICON specific diagnosis information is notified by Dia.Ext_Diag flag set to 1. Once the master was able to catch the diagnosis information, it returns to the standard cyclic data exchange mode. To notify the termination of the diagnosis incident, the ICON2000v4_DP V1 interface send a “high priority” response. The master answers with a “Slave_Diag” request that is followed by a “Slave_Diag” response with Dia.Ext_Diag flag set to 0.

Figure 17

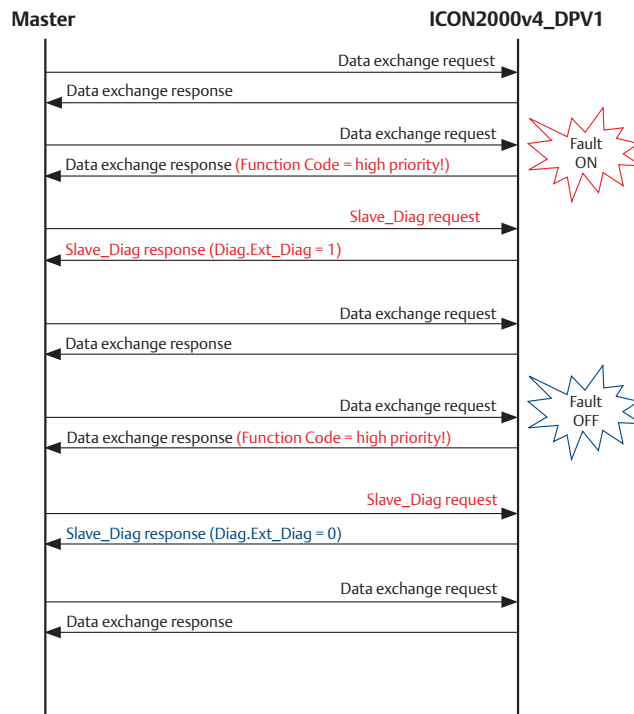

The diagnose message implemented by ICON2000v4_DPV1 has the following structure:

Figure 18

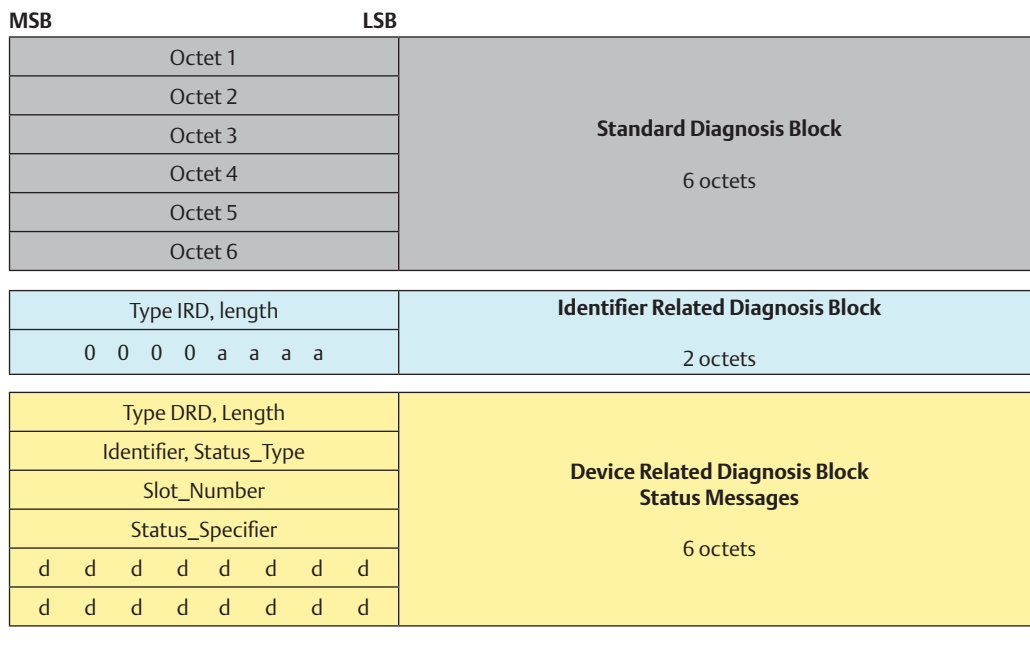

11.1.3.1 Standard Diagnosis Block

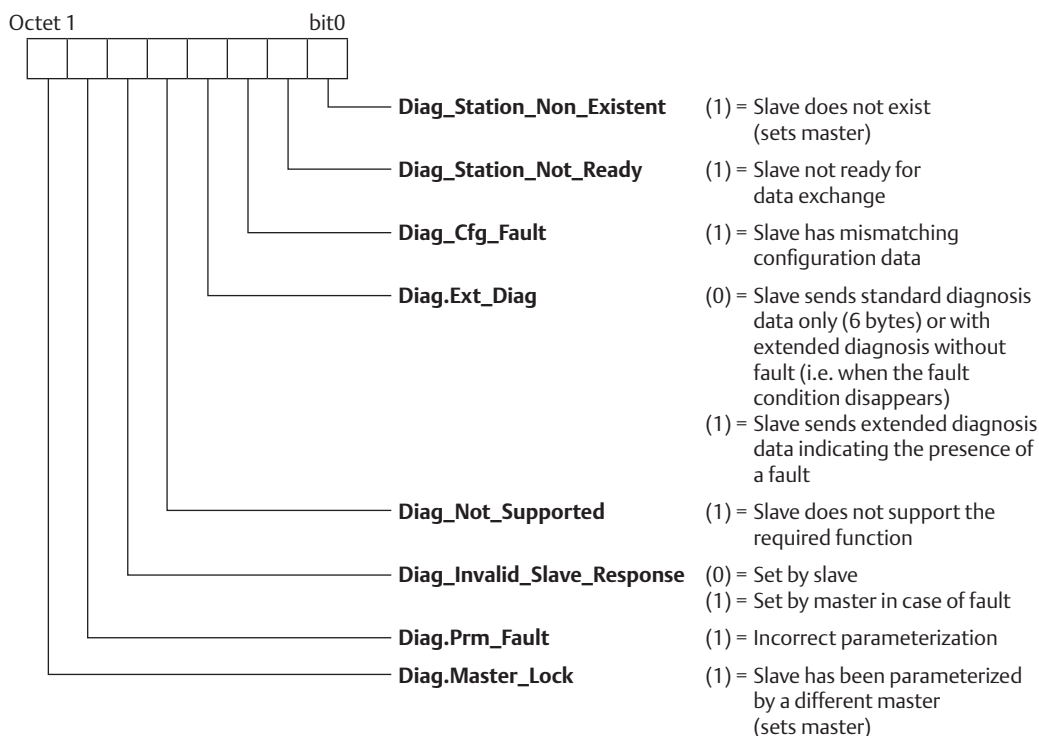

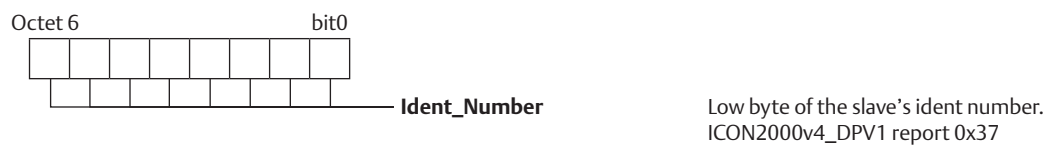
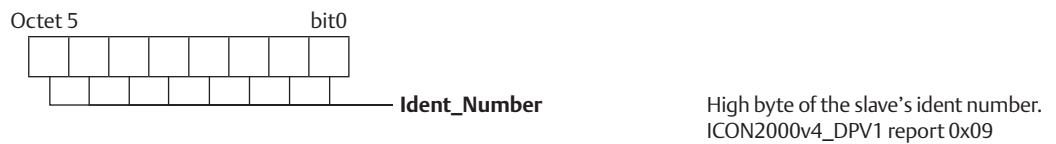
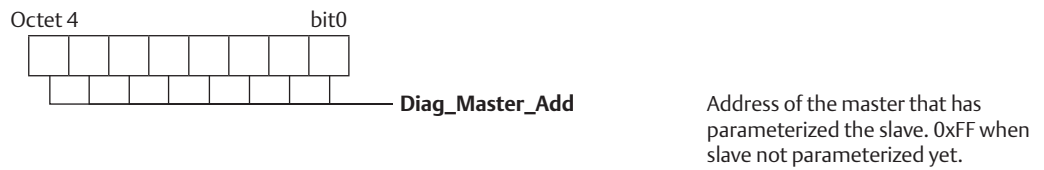
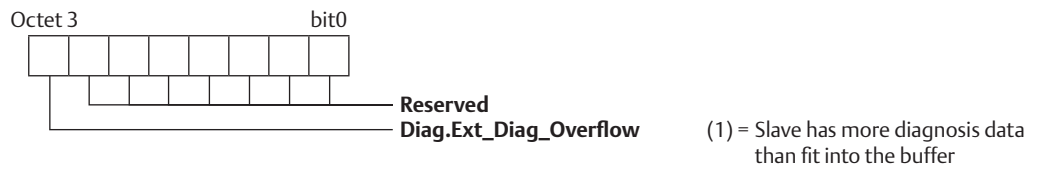
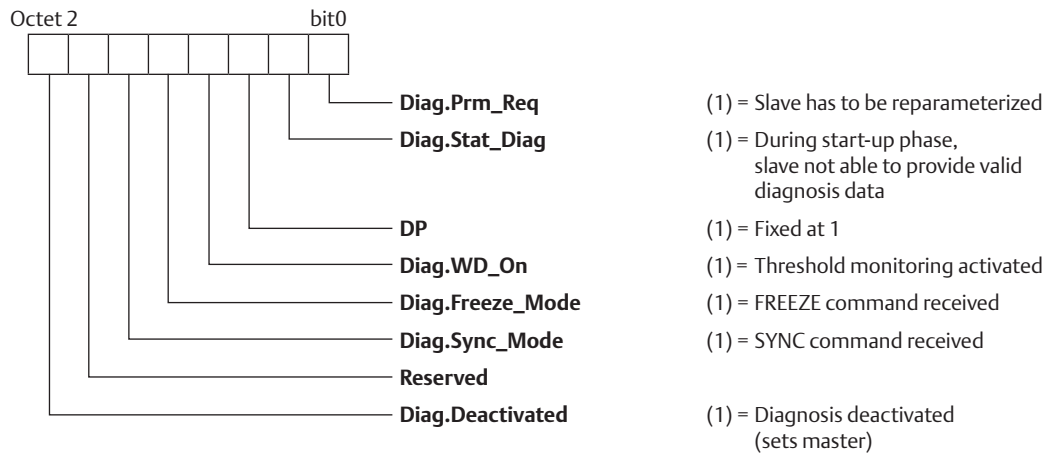

11.1.3.2 Identifier Related Diagnosis Block

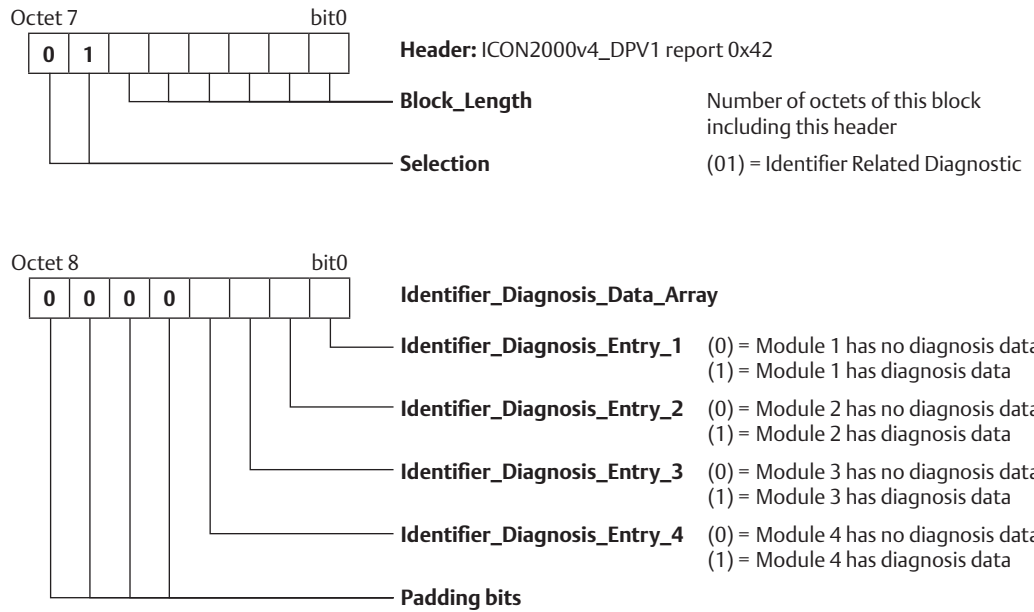

11.1.3.3 Device Related Diagnosis Block

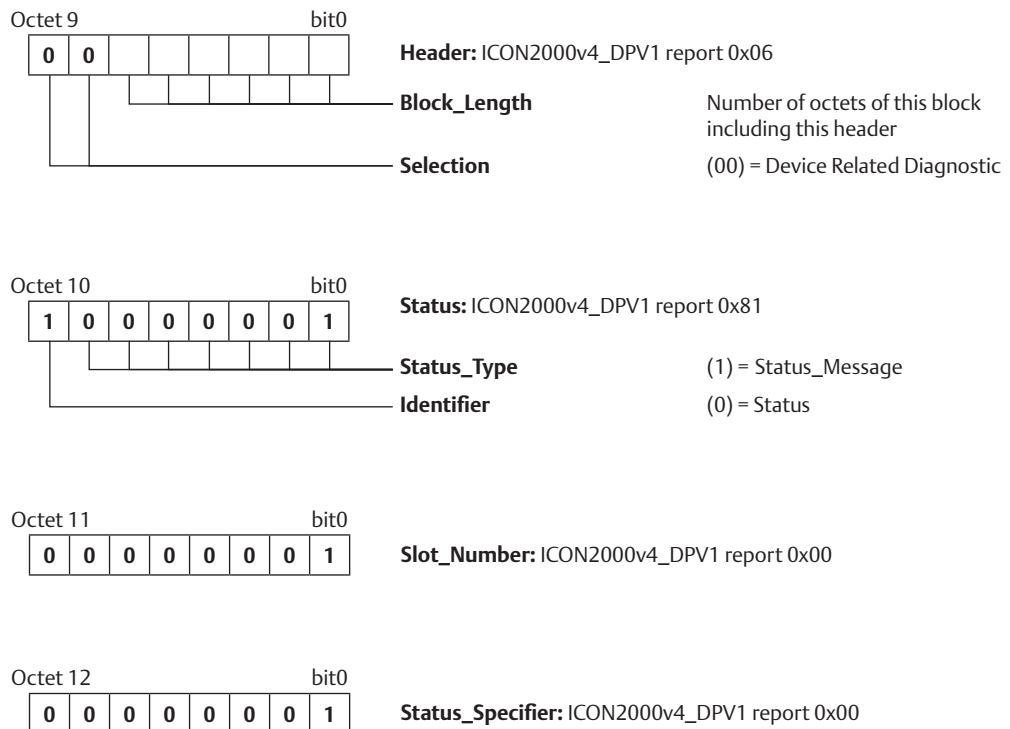

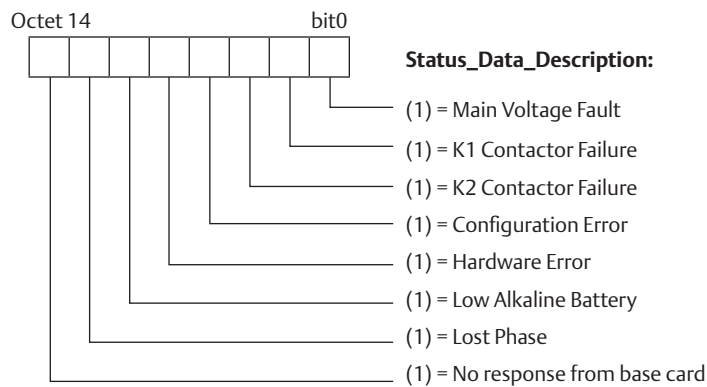
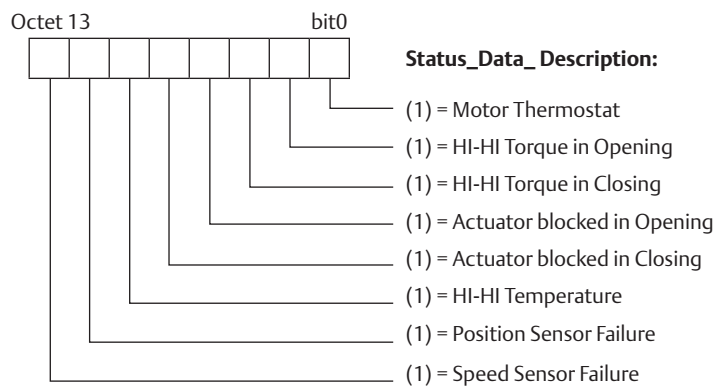

The meaning of every diagnosis event listed in the extended diagnosis block is documented in GSD file, where each bit corresponds a specific text to describe the device related diagnosis.

A full Profibus DP Master compliant should be able to show directly the correspondent text in the event of a diagnostic incident.

11.2 Acyclic Communication DPV1

This section explains the composition of the acyclic communication defined as per Profibus DPV1. These information can be reached by Profibus class 2 Master with MS2 services. For this purpose and graphical interface, device specific DTM and EDD interface are available for most of host systems. Additional information about DTM and EDD are available on “MDE196 ICON3000 Profibus DTM Manual”, “MDE234 ICON3000 Profibus EDD for ASM Manual” and “MDE235 ICON3000 Profibus EDD for PDM Manual”.

11.2.1 Nameplate

Slot 0, Index 0, length 26 byte: Actuator type

Byte	Name	Dim	Range	EU
0 - 15	Actuator Type	16 byte	-	String
16 - 25	Software revision	10 byte	-	String ##

Note:

The Software revision string is made up of the base software revision and Profibus interface revision with this format:

SW rev. base (4 byte) – obj. #5	blank	blank	SW rev. interface (4 byte)
---------------------------------	-------	-------	----------------------------

Slot 0, Index 1, length 28 byte: Actuator Serial number

Byte	Name	Dim	Range	EU
0 - 27	Serial number	28 byte	-	String

Slot 0, Index 2, length 28 byte: Valve Tag name

Byte	Name	Dim	Range	EU
0 - 27	Valve Tag name	28 byte	-	String

11.2.2 General Data

Slot 1, Index 0, length 4 byte: General data about current working condition

Byte	Name	bit	Description
0	Byte 0	0	Close limit
		1	Open limit
		2	Moving
		3	Monitor relay
		4	Selector in local
		5	Selector in remote
		6	Alarm
		7	Warning
1	Byte 1	0	DIN 1
		1	DIN 2
		2	DIN 3
		3	DIN 4
		4	DIN 5
		5	DIN 6
		6	Interlock open
		7	Interlock close
2	Byte 2	0	Fail-safe action
		1	Opening
		2	Closing
		3	Selector in off
		4	ESD active
		5	HW remote mode
		6	Positioner mode
		7	Motion inhibited
3	Byte 3	0	Channel 1 active
		1	Aux. in open
		2	Aux. in close
		3	Aux. in stop
		4	Aux. in bus on
		5	Reserved
		6	Reserved
		7	Reserved

11.2.3 Maintenance Information

Slot 2, Index 0, length 22 byte: General maintenance information

Byte	Name	Dim	Range	EU
0 - 1	Actuator position	2 byte	0 - 1000	-
2 - 3	Output torque	2 byte	-100,+100	-
4 - 5	Opening time	2 byte	0 - 65, 535	Seconds
6 - 7	Closing time	2 byte	0 - 65, 535	Seconds
8 - 11	Contact cycles	4 byte	0 - 4, 294, 967, 295	Unit
12 - 15	Motor Run Time	4 byte	0 - 4, 294, 967, 295	Hours
16 - 19	Time Without Power	4 byte	0 - 4, 294, 967, 295	Hours
20 - 21	Utilization Rate	2 byte	0 - 65, 535	%

Slot 2, Index 1, length 22 byte: Recent maintenance information

Byte	Name	Dim	Range	EU
0 - 3	Test Date	4 bytes	dd-mm-20yy	BCD format
4 - 7	Recent log date	4 bytes	dd-mm-20yy	BCD format
8 - 11	Recent Contactor Cycles	4 bytes	0 - 4, 294, 967, 295	Unit
12 - 13	Recent motor Run Time	4 bytes	0 - 4, 294, 967, 295	Hours
14 - 17	Recent Time Without Power	4 bytes	0 - 4, 294, 967, 295	Hours
18 - 21	Recent Utilization Rate	2 bytes	0 - 65, 535	%

Slot 2, Index 2, length 20 byte: Torque profile

Byte	Name	Dim	Range	EU
0	Reserved	1 byte	-	-
1	Opening Break out	1 byte	0 - 255	%
2	Reserved	1 byte	-	-
3	Opening Peak	1 byte	0 - 255	%
4	Reserved	1 byte	-	-
5	Opening Ending	1 byte	0 - 255	%
6 - 9	Date Opening	4 byte	dd-mm-20yy	BCD format
10	Reserved	1 byte	-	-
11	Closing Break out	1 byte	0 - 255	%
12	Reserved	1 byte	-	-
13	Closing Peak	1 byte	0 - 255	%
14	Reserved	1 byte	-	-
15	Closing Ending	1 byte	0 - 255	%
16 - 19	Date Closing	4 byte	dd-mm-20yy	BCD format

Slot 2, Index 3, length 20 byte: Reference torque profile

Byte	Name	Dim	Range	EU
0	Reserved	1 byte	-	-
1	Ref. Opening Break out	1 byte	0 - 255	%
2	Reserved	1 byte	-	-
3	Ref. Opening Peak	1 byte	0 - 255	%
4	Reserved	1 byte	-	-
5	Ref. Opening Ending	1 byte	0 - 255	%
6 - 9	Date Ref. Opening	4 byte	dd-mm-20yy	BCD format
10	Reserved	1 byte	-	-
11	Ref. Closing Break out	1 byte	0 - 255	%
12	Reserved	1 byte	-	-
13	Ref. Closing Peak	1 byte	0 - 255	%
14	Reserved	1 byte	-	-
15	Ref. Closing Ending	1 byte	0 - 255	%
16 - 19	Date Ref. Closing	4 byte	dd-mm-20yy	BCD format

Slot 2, Index 4, length 20 byte: Nominal torque and maintenance date

Byte	Name	Dim	Range	EU
0	Nominal Torque EU	1 byte	0	Torque lbf
			1	Torque Nm
			2	Thrust lb
			3	Thrust kN
1 - 7	Nominal Torque value	7 byte	-	string
8 - 11	Next Maintenance Date	4 byte	dd-mm-20yy	BCD format
12 - 15	Last Maintenance Date	4 byte	dd-mm-20yy	BCD format
16 - 19	Startup Date	4 byte	dd-mm-20yy	BCD format

11.2.4 Alarm and Warning Log

Slot 3, Index 0, length 30 byte: Alarm log: the first three records

Byte	Name	Dim	Range	EU
0	Alarm #1: Code	1 byte	0 - 255	-
1	Reserved	1 byte	-	-
2 - 5	Alarm #1: Date	4 byte	dd-mm-20yy	BCD format
6 - 9	Alarm #1: Time	4 byte	00-hh-mm-ss	BCD format
10	Alarm #2: Code	1 byte	0 - 255	-
11	Reserved	1 byte	-	-
12 - 15	Alarm #2: Date	4 byte	dd-mm-20yy	BCD format
16 - 19	Alarm #2: Time	4 byte	00-hh-mm-ss	BCD format
20	Alarm #3: Code	1 byte	0 - 255	-
21	Reserved	1 byte	-	-
22 - 25	Alarm #3: Date	4 byte	dd-mm-20yy	BCD format
26 - 29	Alarm #3: Time	4 byte	00-hh-mm-ss	BCD format

Slot 3, Index 1, length 20 byte: Alarm log: the last two records

Byte	Name	Dim	Range	EU
0	Alarm #4: Code	1 byte	0 - 255	-
1	Reserved	1 byte	-	-
2 - 5	Alarm #4: Date	4 byte	dd-mm-20yy	BCD format
6 - 9	Alarm #4: Time	4 byte	00-hh-mm-ss	BCD format
10	Alarm #5: Code	1 byte	0 - 255	-
11	Reserved	1 byte	-	-
11 - 15	Alarm #5: Date	4 byte	dd-mm-20yy	BCD format
16 - 19	Alarm #5: Time	4 byte	00-hh-mm-ss	BCD format

Slot 3, Index 2, length 30 byte: Warning log: the first three records

Byte	Name	Dim	Range	EU
0	Warning #1: Code	1 byte	0 - 255	-
1	Reserved	1 byte	-	-
2 - 5	Warning #1: Date	4 byte	dd-mm-20yy	BCD format
6 - 9	Warning #1: Time	4 byte	00-hh-mm-ss	BCD format
10	Warning #2: Code	1 byte	0 - 255	-
11	Reserved	1 byte	-	-
11 - 15	Warning #2: Date	4 byte	dd-mm-20yy	BCD format
16 - 19	Warning #2: Time	4 byte	00-hh-mm-ss	BCD format
20	Warning #3: Code	1 byte	0 - 255	-
21	Reserved	1 byte	-	-
22 - 15	Warning #3: Date	4 byte	dd-mm-20yy	BCD format
26 - 29	Warning #3: Time	4 byte	00-hh-mm-ss	BCD format

Slot 3, Index 3, length 20 byte: Warning log: the last two records

Byte	Name	Dim	Range	EU
0	Warning #4: Code	1 byte	0 - 255	-
1	Reserved	1 byte	-	-
2 - 5	Warning #4: Date	4 byte	dd-mm-20yy	BCD format
6 - 9	Warning #4: Time	4 byte	00-hh-mm-ss	BCD format
10	Warning #5: Code	1 byte	0 - 255	-
11	Reserved	1 byte	-	-
12 - 15	Warning #5: Date	4 byte	dd-mm-20yy	BCD format
16 - 19	Warning #5: Time	4 byte	00-hh-mm-ss	BCD format

11.2.5 Maintenance Commands

Slot 4, Index 0, length 1 byte: Maintenance information (Write Only)

Byte	Name	Dim	Range	EU
0	Maintenance command	1 byte	bit0 = 1 bit1 = 1	Clear Recent Data Log Set Torque Reference

Slot 4, Index 1, length 4 byte: Maintenance information (Read and Write)

Byte	Name	Dim	Range	EU
0 - 3	Next Maintenance Date	4 byte	dd-mm-20yy	BCD format

Slot 4, Index 2, length 4 byte: Maintenance information (Read and Write)

Byte	Name	Dim	Range	EU
0 - 3	Last Maintenance Date	4 byte	dd-mm-20yy	BCD format

Slot 4, Index 3, length 4 byte: Maintenance information (Read and Write)

Byte	Name	Dim	Range	EU
0 - 3	Startup Date	4 byte	dd-mm-20yy	BCD format

Slot 4, Index 4, length 8 byte: Date and Time (Write Only)

Byte	Name	Dim	Range	EU
0 - 3	Current Date	4 bytes	dd-mm-20yy	BCD format
4 - 7	Current Time	4 bytes	00-hh-mm-ss	BCD format

Section 12: Data at Local Operator Interface

Below is the description of the facilities available by the view and setup menu of ICON3000.

12.1 Bus Control

DIN 1 - DIN 6

- By this routine, it is possible to choose the condition that sets the status of bits DIN1 - 6 of byte 4 when module 2 has been selected. See Table 3 for the list of the available conditions:

Table 3.

STATUS		ALARM	
<ul style="list-style-type: none"> • open limit • closed limit • position >= xx % • position <= xx % • closing • opening • motor running • blinker 	<ul style="list-style-type: none"> • mid-travel position • local selected • remote selected • local stop active • ESD signal on • manual operation • heater 	<ul style="list-style-type: none"> • motor HI-HI temperature • HI-HI torque • HI-HI torque in OP • HI-HI torque in CL • valve jammed • warnings • EFS mid-travel alarm • Interlock/PTS-icon 	<ul style="list-style-type: none"> • valve jammed in OP • valve jammed in CL • low battery (if present) • mid-travel alarm in CL/OP • EFS in manual • PTS failed • MAINS (only as8) • EFS coil OFF

The following setting is supplied as standard:

- DIN 1: mid-travel position
- DIN 2: local stop active
- DIN 3: motor over-temperature (motor thermostat alarm)
- DIN 4: over-torque (HI-HI torque alarm)
- DIN 5: valve jammed alarm
- DIN 6: mid-travel alarm in OP/CL

INTERFACE MODE

It is possible to indicate the requested working algorithm to the interface firmware. The following selections are available:

- **SINGLE CH1:** The interface enables only the channel 1.
- **REDUNDANT BIFFI:** The interface acts redundancy as Biffi specific algorithm. (This functionality must be requested when ordering the actuator.)
- **REDUNDANT 2.212:** The interface acts redundancy as Profibus PNO Order No: 2.212 specification algorithm. (This functionality must be requested when ordering the actuator.)
- **SINGLE CH2:** The interface enables only the channel 2. (This functionality works only if the slave interface is redundant.)

PRIMARY

- **NODE:** By this function, it is possible to enter the Profibus slave node address of the Primary Slave. The available address range is from 1 - 126. The address must be selected according to the Profibus network layout where the actuator is inserted.
- **TERMINATION:** Status: By this routine, the internal termination of the Primary Slave can be connected to the bus line (ON/OFF). Set "TERMINATION = ON" only if the actuator is at the beginning or at the end of the Profibus line.

BACKUP

- **NODE:** By this function, it is possible to enter the Profibus slave node address of the Backup Slave. The available address range is from 1 - 126. The address must be selected according to the Profibus network layout where the actuator is inserted.
 - SYSTEM REDUNDANCY: BACKUP NODE = PRIMARY NODE
 - FLYING REDUNDANCY: BACKUP NODE = PRIMARY NODE +64
- **TERMINATION:** Status: By this routine, the internal termination of the Backup Slave can be connected to the bus line (ON/OFF). Set "TERMINATION = ON" only if the actuator is at the beginning or at the end of the Profibus line.

Configuration procedure:

- Move the local selector to OFF and then press simultaneously OPEN and STOP. Select the language and then enter the password according to the instructions "entering the set-up mode". When the message of display is "SET-UP MODE OK?" press YES. Press YES to select "ACTUATOR SET-UP" menu, press NO to scroll the list of available routines and then press YES to select BUS control.
- Press NO if the condition linked to DIN 1 is correct, or press YES to change, press NO to select new option, then press YES to confirm.
- Repeat the previous step for DIN 2, DIN 3 - DIN 6.
- Press YES if the INTERFACE MODE is correct, or press NO to change.
- Press YES to enter in configuration of PRIMARY channel or press NO to skip configuration of Primary channel.
- Press YES if the configured value of the node address (NODE) is correct (from 1 - 126), or press NO to change, then press YES.
- Press YES if the configured status of termination (TERMINATION) is correct (ON/OFF), or press NO to change, then press YES.
- Press YES to enter in configuration of BACKUP channel or press NO to skip configuration of Backup channel. Like PRIMARY menu, the BACKUP menu contains the NODE and TERMINATION settings.

View procedure:

- Move the local selector to OFF and then press simultaneously OPEN and STOP. Select the language and then enter the password according to the instructions "entering the view mode". When the message of display is "VIEW MODE OK?" press YES. Press YES to select "ACTUATOR SET-UP" menu, press NO to scroll the list of available routines and then press YES to select BUS CONTROL.
- Press YES to scroll the list of BUS CONTROL parameters.

12.2 Node Report

The following procedure allows seeing the most significant info relevant to the bus data transmission of the PRO2000v4_RED interface card.

The following indications are reported:

INTERFACE STATUS

This information reports the status of Profibus slave interface card interface. It is a hexadecimal word. The Higher Byte of the word represents the status of Primary (IM1) and the Lower Byte represents the status of Backup (IM2).

Bit Field representation:

b14-15 = IM1 WD_State

- 00 = 'Baud_Search' state
- 01 = 'Baud_Control' state
- 10 = 'DP_Control' state
- 11 = not possible

b12-13 = IM1 DP_State

- 00 = 'Wait_Prm' state
- 01 = 'Wait_Cfg' state
- 10 = 'DATA_EX' state
- 11 = not possible

b11 = IM1 RAM Access Violation

- 0 = no address violation
- 1 = address violation

b10 = IM1 Diag_Flag

- 0 = the DP master fetch the diagnostic buffer
- 1 = the DP master has not yet fetched the diagnostic buffer

b9 = IM1 FDL_IND_ST

- 0 = no FDL indication is temporarily buffered
- 1 = FDL indication is temporarily buffered

b8 = IM1 Offline/ Passive Idle

- 0 = VPC3 is in offline
- 1 = VPC3 is passive idle

b6-7 = IM2 WD_State

- 00 = 'Baud_Search' state
- 01 = 'Baud_Control' state
- 10 = 'DP_Control' state
- 11 = not possible

b4-5 = IM2 DP_State

- 00 = 'Wait_Prm' state
- 01 = 'Wait_Cfg' state
- 10 = 'DATA_EX' state
- 11 = not possible

b3 = IM2 RAM Access Violation

- 0 = no address violation
- 1 = address violation

b2 = IM2 Diag_Flag

- 0 = the DP master fetch the diagnostic buffer
- 1 = the DP master has not yet fetched the diagnostic buffer

b1 = IM2 FDL_IND_ST

- 0 = no FDL indication is temporarily buffered
- 1 = FDL indication is temporarily buffered

b0 = IM2 Offline/ Passive Idle

- 0 = VPC3 is in offline
- 1 = VPC3 is passive idle

RED MACHINE STAT

This information reports the status of redundancy algorithm of Profibus redundant slave interface of the firmware at the PNO Order No: 2.212 specification. It is a hexadecimal word. The Higher Byte of the word represents the status of Primary (IM1) and the Lower Byte represents the status of Backup (IM2). Refer to PNO Order No: 2.212 Slave redundancy specification for details on redundancy state machine status values.

BUS CARD REPORT

By this routine, it is possible to show the 64 characters identification string relevant to the PRO2000v4_RED interface.

PRIMARY CARD

- **BAUD RATE:** Represents the baud rate detected and hooked by primary channel.
 - 0 = 12,00 Mbit/s
 - 1 = 6,00 Mbit/s
 - 2 = 3,00 Mbit/s
 - 3 = 1,50 Mbit/s
 - 4 = 500,00 Kbit/s
 - 5 = 187,50 Kbit/s
 - 6 = 93,75 Kbit/s
 - 7 = 45,45 Kbit/s
 - 8 = 19,20 Kbit/s
 - 9 = 9,60 Kbit/s
 - 15 = after reset and during baud rate search
- **ACTIVE MODULE:** Displays the selected active module of primary channel.

BACKUP CARD

- **BAUD RATE:** Represents the baud rate detected and hooked by backup channel.
 - 0 = 12,00 Mbit/s
 - 1 = 6,00 Mbit/s
 - 2 = 3,00 Mbit/s
 - 3 = 1,50 Mbit/s
 - 4 = 500,00 Kbit/s
 - 5 = 187,50 Kbit/s
 - 6 = 93,75 Kbit/s
 - 7 = 45,45 Kbit/s
 - 8 = 19,20 Kbit/s
 - 9 = 9,60 Kbit/s
 - 15 = after reset and during baud rate search
- **ACTIVE MODULE:** Displays the selected active module of backup channel.

MB REC-COUNTER: Counter for consecutive communication error between Base card and PRO2000v4_RED interface card. The counter resets every good communication message which is present.

MB GEN-COUNTER: Counter for communication error between Base card and PRO2000v4_RED interface. The counter resets when power off.

View procedure:

- Move the local selector to OFF or REMOTE and then press YES until the display shows NODE REPORT. Press NO to exit or press YES to scroll the list of transmission information.

12.3 Bus Signal Failure Indication

In case of loss of bus signal, a warning is generated. It is signalled by the flashing of the relevant ALARM/WARNING LED and by indication on the local 2 lines/16 character display.

This page is intentionally left blank

Biffi Italia s.r.l.
Strada Biffi 165
29017 Fiorenzuola d'Arda (PC)
Italy
T +39 0523 944 411

For complete list of sales and manufacturing sites, please visit
www.biffi.it or contact us at biffi_italia@biffi.it

VCIOM-16870-EN ©2022 Biffi. All rights reserved.

The contents of this publication are presented for information purposes only, and while every effort has been made to ensure their accuracy, they are not to be construed as warranties or guarantees, express or implied, regarding the products or services described herein or their use or applicability. All sales are governed by our terms and conditions, which are available on request. We reserve the right to modify or improve the designs or specifications of our products at any time without notice.

