

Biffi OLGA

Double-Acting Hydraulic Actuator

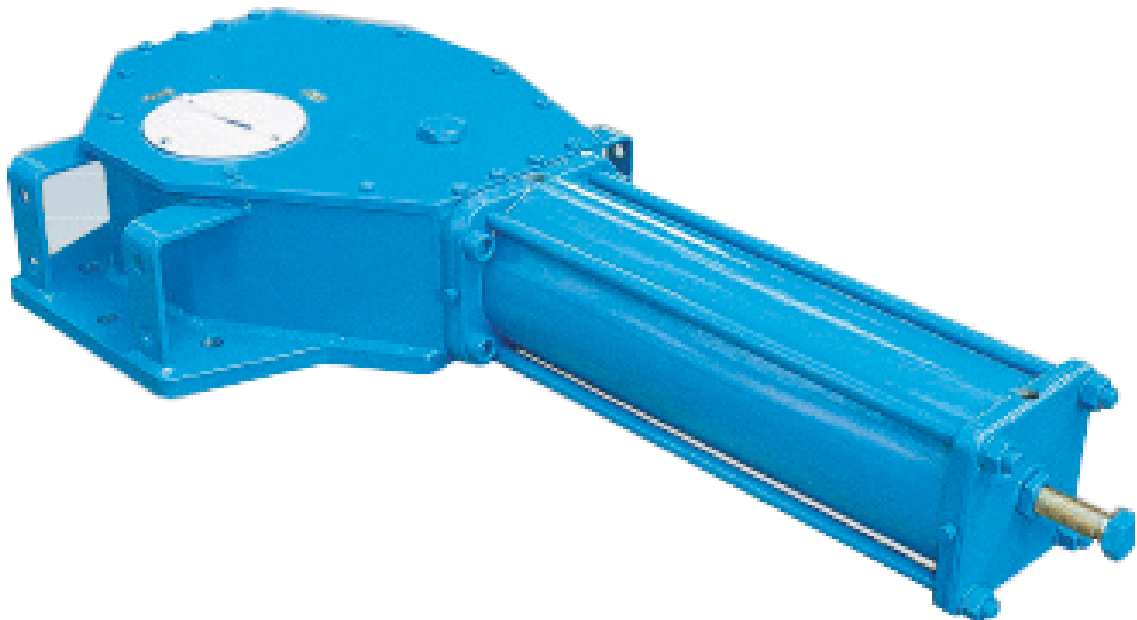

Revision Details

Rev.	Date	Description	Prepared	Checked	Approved
5	December 2020	Migration to new template			
4	20/04/18	Revised data-plate	Ermanni	Orefici	Vigliano
3	18/04/16	Updated applicable regulation (Chapter 1.1.1)	Ermanni	Orefici	Vigliano
2	31/07/12	General update	Ermanni	Stoto	Vigliano
1	17/11/10	General update	Ermanni	Stoto	Vigliano
0	05/05/99	Document Release	Lazzarini	Aliani	Ziveri

Table of Contents

Section 1: General Warnings

1.1	Generalities.....	1
1.1.1	Applicable Regulation	1
1.1.2	Terms and Conditions.....	1
1.2	Identification Plate	2
1.3	Introducing the Actuator.....	3
1.4	Data Sheet	3

Section 2: Installation

2.1	Checks Upon Actuator Receipt	4
2.2	Actuator Handling.....	4
2.3	Storage	8
2.4	Actuator Assembly on the Valve	9
2.4.1	Types of Assembly	9
2.4.2	Assembly Procedure.....	10
2.5	Hydraulic Connections.....	11
2.6	Electrical Connections (If Any).....	12
2.7	Commisioning	13

Section 3: Operation and Use

3.1	Operation Description.....	14
3.2	Residual Risks.....	16
3.3	Operations	16
3.3.1	Local Manual Operation.....	16
3.3.2	Emergency Manual Operation by MHP	18
3.3.3	Emergency Manual Operation by MSJ - MHW.....	19
3.4	Calibration of the Angular Stroke	19
3.5	Calibration of Micro-switches (If Foreseen).....	24
3.6	Calibration of the Operation Time (Optional – If Foreseen).....	25

Section 4: Operational Tests and Inspections

	Operational Tests and Inspections.....	27
--	--	----

Section 5: Maintenance

5.1	Periodic Maintenance.....	28
5.1.1	Check and Restore Oil Level in the Hydraulic Control Unit.....	29
5.2	Extraordinary Maintenance	31
5.2.1	Replacement of Cylinder Seals	31
5.3	Lubrication of Mechanism	35
5.4	Dismantling and Demolition	36

Section 6: Troubleshooting

6.1 Failure or Breakdown Research 37

Section 7: Layouts

7.1 Spare Parts Order 38
7.2 Parts List for Maintenance and Replacing Procedure 39

Section 8: Date Report for Maintenance Operations

Date Report for Maintenance Operations.....47

NOTICE

Biffi Italia s.r.l. pays the highest attention to collecting and verifying the documentation contained in this user manual. However Biffi Italia s.r.l. is not liable for any mistakes contained in this manual, for damage or accidents due to the use of the latter. The information contained is of exclusive reserved ownership of Biffi Italia s.r.l. and may be modified without prior notice. All rights reserved.

Section 1: General Warnings

NOTICE

The manual is an integral part of the machine, it should be carefully read before carrying out any operation and it should be kept for future references.

1.1 Generalities

Biffi Italia s.r.l. actuators are conceived, manufactured and controlled according to the Quality Control System in compliance with EN-ISO 9001 international regulation.

1.1.1 Applicable Regulation

EN ISO 12100:2010:	Safety of machinery – General principles for design – Risk assessment and risk reduction
2006/42/EC:	Machine directive
2014/68/EU:	Directive for pressure PED equipment
2014/35/EU:	Directive for low voltage equipment
2014/30/EU:	Directive for the electromagnetic compatibility
2014/34/EU:	Directive and safety instructions for use in hazardous area

1.1.2 Terms and Conditions

Biffi Italia s.r.l. guarantees that all the items produced are free of defects in workmanship and manufacturing materials and meet relevant current specifications, provided they are installed, used and serviced according to the instructions contained in the present manual. The warranty can last either one year from the date of installation by the initial user of the product, or eighteen months from the date of shipment to the initial user, depending on which event occurs first. All detailed warranty conditions are specified in the documentation forwarded together with the product. This warranty does not cover special products or components not warranted by subcontractors, or materials that were used or installed improperly or were modified or repaired by unauthorized staff. In the event that a fault condition be caused by improper installation, maintenance or use, or by irregular working conditions, the repairs will be charged according to applicable fees.

The warranty and Biffi Italia s.r.l liability shall lapse in the event that any modification or tampering whatsoever be performed on the actuator.



1.2 Identification Plate

⚠ WARNING

It is forbidden to modify the information and the marks without previous written authorization by Biffi Italia s.r.l.

The plate fastened on the actuator contains the following information (Figure 1).

Figure 1 Data Plate

		BIFFI ITALIA Fiorenzuola d' Arda 29017(PC) - ITALY			
ORDER _____					
MODEL _____					
S/N _____		AMB. TEMP. _____			
TAG N° _____		ND _____			
SUPPLY PRES. RANGE _____		MOP _____			
FL. GROUP _____		PED CAT. _____		FL. TYPE _____	
CYL. PS _____		CYL. TS _____		MM/YYYY _____	
CYL.PT _____		TEST DATE _____		CYL WEIGHT _____	
		Ref.:		LY:	
				ISO	

1.3 Introducing the Actuator

The hydraulic actuator series OLGAs was engineered and is manufactured to provide maximum torque output with minimum supply pressure. The OLGAs actuators is suitable for any quarter turn application such as ball, plug, butterfly valves or dampers, in both ON-OFF and Modulating heavy duty service.

The actuator (see Figure 2) is made up of a weatherproof scotch yoke mechanism transforming the linear movement of the pneumatic cylinder (on closing or opening) into the rotary movement, which is necessary for operation. The angular stroke of the yoke is adjustable between 82° and 98° by means of the external mechanical stops screwed into the left wall of the mechanism housing and into the end flange of the pneumatic cylinder. The cover of the scotch yoke mechanism is arranged for the assembly of the required accessories (positioner, signalling limit switches, position transducer, etc.) by means of proper matching units. The above mentioned accessories are operated by the actuator drive sleeve. The housing of the scotch yoke mechanism has a flange with threaded holes to fix the actuator to the valve either directly or, if required, with the interposition of an adaptor flange or a mounting bracket. The actuator yoke has a hole with keyways suitable for the assembly of an insert bush the internal hole of which is machined (by Biffi or at Customer's care), according to the shape and dimensions of the valve stem. Biffi can supply different types of control system following Customer's requirements.

The expected lifetime of actuator is approximately 25 years.

Figure 2 Identification of Actuator Parts

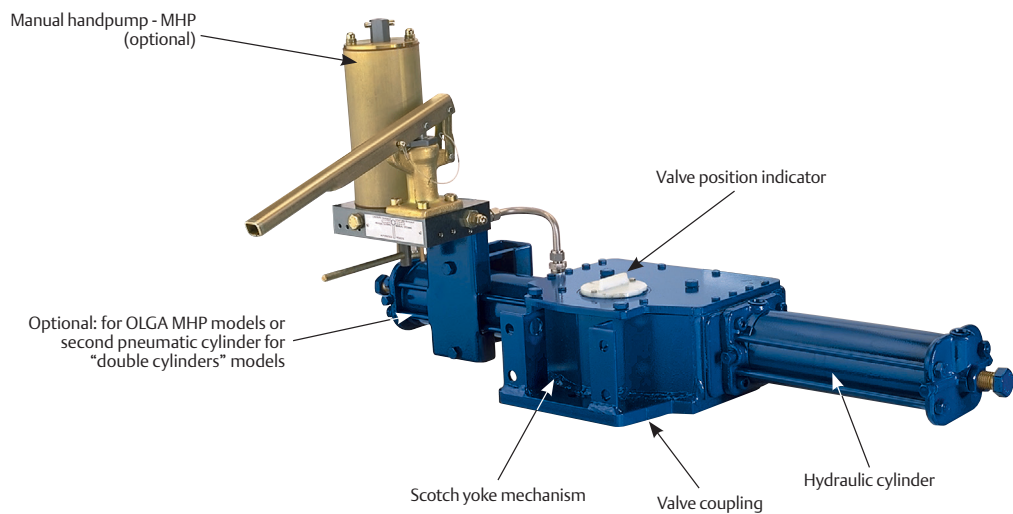

1.4 Data Sheet

Supply fluid	Hydraulic oil, special version for fire-resistant fluids
Operating temperature	Standard: from -30 °C to +100 °C Optional: from -60 °C to +140 °C
Supply pressure	Please refer to technical document: "actuator data-sheet"

Section 2: Installation

2.1 Checks Upon Actuator Receipt

- Check that the model, the serial number of the actuator and the technical data reported on the identification plate correspond with those of order confirmation (Section 1.2).
- Check that the actuator is equipped with the fittings as provided for by order confirmation.
- Check that the actuator was not damaged during transportation: if necessary renovate the painting according to the specification reported on the order confirmation.
- If the actuator is received already assembled with the valve, its settings have already been made at the factory.
- If the actuator is delivered separately from the valve, it is necessary to check, and if required, to adjust, the settings of the mechanical stops (Section 3.4) and of micro-switches (if any) (Section 3.5).

2.2 Actuator Handling

NOTICE

The lifting and handling of the actuator must be done by qualified personnel and in accordance with the laws and regulations in force. Avoid the lifted actuator to be hung above the personnel.

⚠ WARNING

The actuator must be lifted by means of a suitable lifting apparatus. The weight of the actuators is indicated in the technical documentation attached to the equipment itself. For lifting and moving the actuator, use only hooks fitted with safety latch, like the one, for example, shown in Figure 3.

Figure 3 Example of Hook with Safety Latch



Figure 4 Lifting points for OLGA / OLGA-MHP / OLGA-MSJ

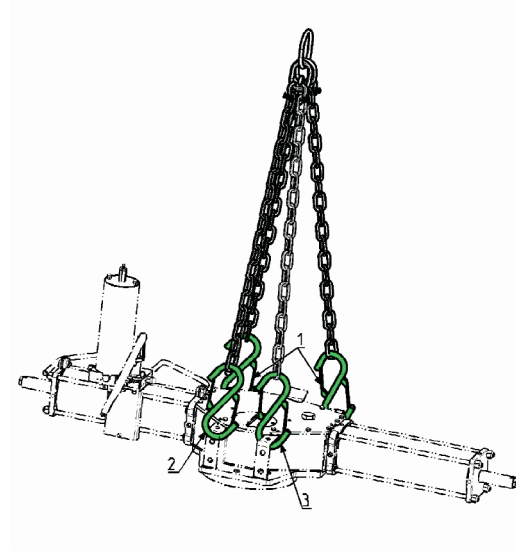
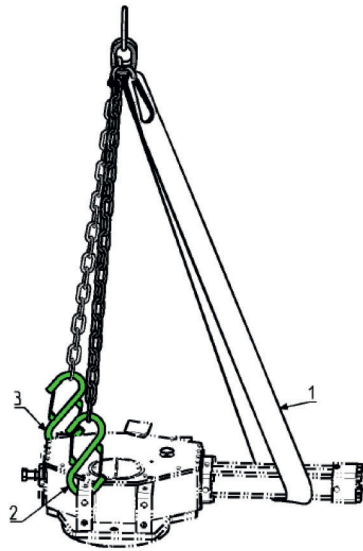

1, 2 = Lifting points (obligatory)
3 = Balancing point

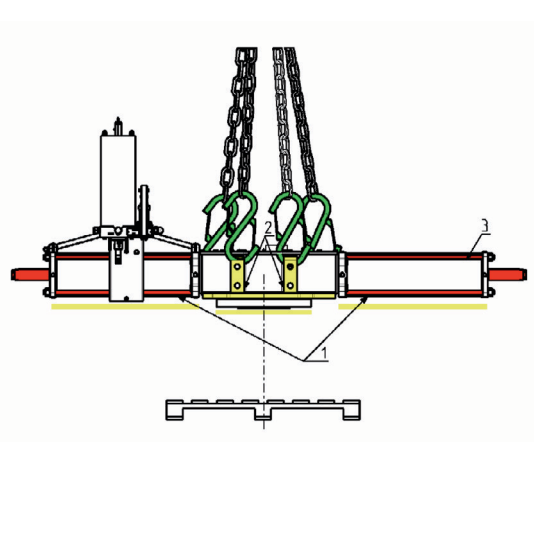
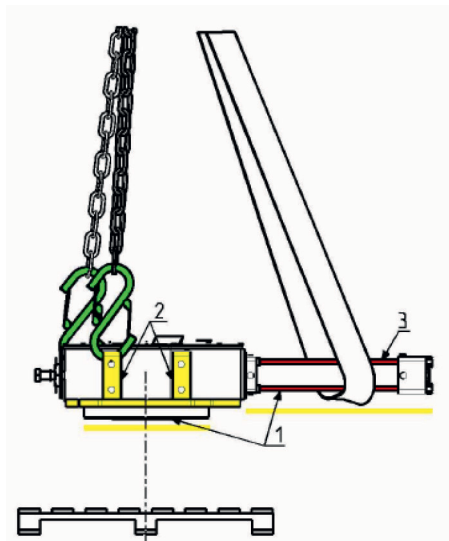

1 = Point of support
2 = Supports for lateral positioning

⚠ WARNING

3 = Do not lay the actuator on tie rods of cylinder/s and do not lay the actuator on accessories (manual handpump, manual jackscrew, pneumatic control group etc.).

- **For lifting unbalanced loads, use ropes of different lengths or chains with adjustable length.**
- **Check each time the conditions of all lifting equipment used and discard it if not in perfect working order.**
- **Do not knot or twist the ropes so as not to reduce the lifting capacity or produce torsional effects on the load being lifted.**
- **Use the utmost caution and remain at a safe distance from lifted actuator unless absolutely necessary; do not stand or pass under suspended loads.**
- **Pay attention in putting under tension the ropes to prevent the load shifting sideways in an uncontrolled manner.**
- **Use slings of such length that the angles of the leg from vertical are as narrow as possible ($\alpha_{MAX} < 20^\circ$).**
- **During handling, do not transport the suspended actuator above staff members in charge of the operation.**

For the transport of OLGA actuators with hydraulic manual hand-pump, when it was necessary put in horizontal position the tank of MHP, to avoid leakage on oil level stick, substitute these with a blind-plug during the transport (a specific warning label for transport in horizontal position is attached on the MHP body); remove the blind plug and restore the dipstick before operate the actuator with MHP. Biffi hydraulic manual hand-pump must be maintained with tank in upper position to operate the actuator with MHP correctly.

Figure 5

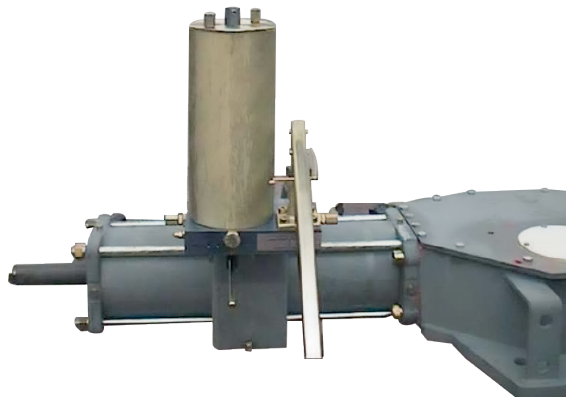

Figure 6

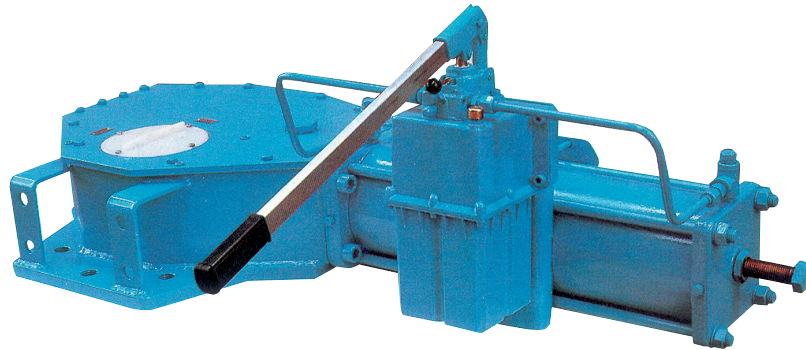
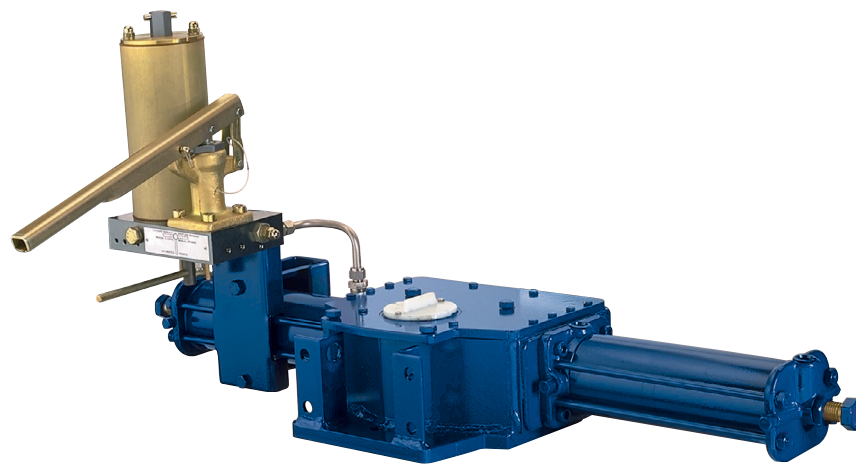
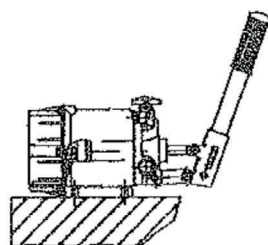

Figure 7



OMFB manual hand-pump should be transported and used with MHP tank in horizontal position, but in position 3 of follow picture (extracted from OMFB technical documentation) it is necessary change the position of suction pipe and breather cap.

Figure 8 Fixing Positions



POSITION 1
Standard application

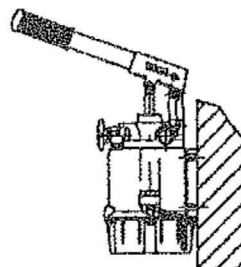

POSITION 2
Standard application

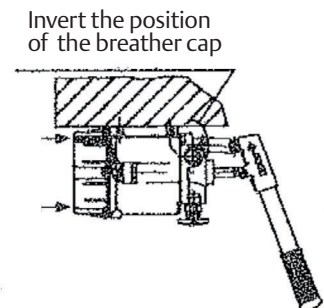

POSITION 3
Change the position of suction pipe from A to B and the breather cap to top side

2.3 Storage

If the actuator needs storage, before installation follow these steps:

- Place it on a wood surface in order not to deteriorate the area of valve coupling.
- Make sure that plastic plugs are present on the hydraulic and electrical connections (if present).
- Check that the cover of the control group and of the limit switch box (if any) are properly closed.

If the storage is long-term or outdoor:

- Keep the actuator protected from direct weather conditions.
- Replace plastic plugs of hydraulic and electrical connections (if any) with metal plugs that guarantee perfect tightness.
- Coat with oil, grease or protection disc, the valve coupling area.
- Periodically operate the actuator (Section 3).

2.4 Actuator Assembly on the Valve

2.4.1 Types of Assembly

For coupling to the valve, the housing is provided with a flange with threaded holes according to Biffi standard tables (SCN6200; SCN6200-1; SCN6201; SCN6201-1). The number, dimensions and diameter of the holes are made in accordance with ISO 5211, but for actuator models 0.3 to 6 the holes are drilled on the centreline in order to allow an easier assembly of an intermediate flange, when required. This intermediate flange (or spool-piece) can be supplied when the valve flange can't directly match the actuator flange in its "standard" configuration. For the biggest actuator models, the actuator flange can be machined in accordance with the valve flange dimensions. The yoke has bored with keyways for coupling to the valve stem, the dimensions of which are according to Biffi standard tables SCN6200* and SCN6201*. If required, for the standard models size 0.3 to 6, Biffi can supply an insert bush with un-machined bore in accordance with Biffi standard table SCN6202. On request the insert bush bore can be machined by Biffi to couple the valve stem. The particular execution of the flange and bushing allow the actuator to be rotated by 90° in 4 different positions according to the following figure:

Figure 9 Insert Bush + Intermediate Coupling Flange

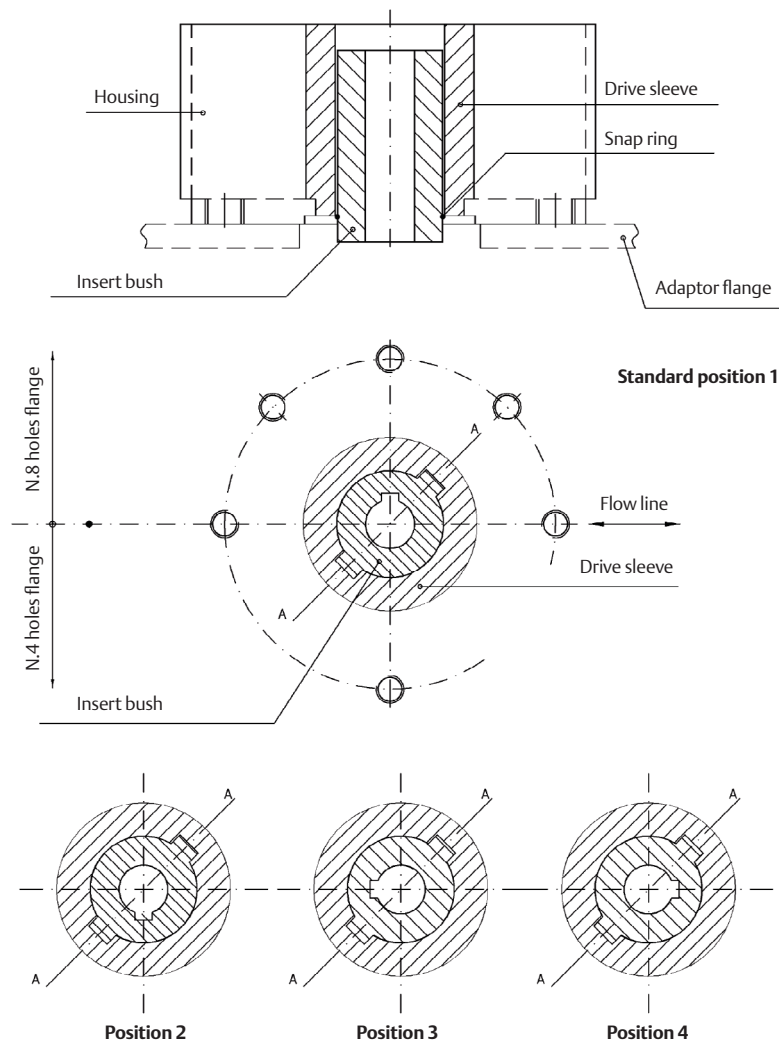

Table 1.

Position 2	Position 3	Position 4
Rotate insert-bush 180° around vertical-standard position (1)	Rotate insert-bush 180° around axis A-A, from position 2	Rotate insert-bush 180° around axis A-A from position 1
Insert bush turned upside down		

The Biffi insert bush with 2 external keys at 45° allows to position the keyway for the valve every 90°. Consequently actuator can be mounted in 4 positions at 90° on top of the valve. For biggest actuator models, the bore of the yoke can be machined according to the dimensions of valve stem.

2.4.2 Assembly Procedure

NOTICE

Failure to comply with the following procedures may impair product warranty.

⚠ WARNING

Installation, commissioning and maintenance and repair works should be carried out by qualified staff. A non-conforming assembly could be the source of serious accidents.

For actuator assembly on the valve:

NOTICE

Check that the assembly position, as shown on the documentation, complies with system's geometry. Check the consistency of the parts of actuator-valve coupling.

- Operate the actuator so that it reaches the position matching valve position (Section 3.3).
- Lubricate valve stem with oil or grease.
- Properly clean and remove grease from coupling flange surfaces.
- Connect, if supplied separately, the adjustment insert to valve stem and fasten it with the special fastening pins.
- Lift the actuator using the special lifting points (Section 2.2).
- Install the actuator so that valve stem inserts in the coupling area. This coupling should be made without forcing.
- Fasten the two parts with the threaded connections (screws, tie rods, nuts). If holes of coupling flanges are not aligned, adequately operate the actuator if necessary move the mechanical stops backwards (Section 3.4).
- Fasten threaded connections. Please refer to Table 2.

Table 2. Nuts Tightening Torque

Threading	Tightening Torque (Nm)
M8	20
M10	40
M12	70
M14	110
M16	160
M20	320
M22	420
M24	550
M27	800
M30	1100
M33	1400
M36	1700

The screwing values in Table 2 were calculated considering the materials ASTM A320 L7 for screws or tie rods and ASTM A194 gr.2H for the nuts.

2.5 Hydraulic Connections

NOTICE

Check that the values of hydraulic supply available are compatible with those reported on the identification plate of the actuator.

⚠ WARNING

The connections should be made by qualified staff. Use pipes, fittings and connections appropriate as for type, material and dimensions.

Connect the actuator to the hydraulic feed line with fittings and pipes in accordance to the plant specifications. They must be sized correctly in order to guarantee the necessary oil flow for the operation of the actuator, with pressure drops not exceeding the maximum allowable value. The shape of the connecting piping must not cause excessive stress to the inlets of the actuator. The piping must be suitably fastened so as not to cause excessive stress or loosening of threaded connections, if the system undergoes strong vibrations. Every precaution must be taken to ensure that any solid or liquid contaminants, which may be present in the hydraulic pipe-work to the actuator, are removed to avoid possible damages to the unit or loss of performance. The inside of the pipes used for the connections must be well-cleaned before use: wash them with suitable substances and blow through them with oil or nitrogen. The ends of the tubes must be well debarred and cleaned. Once the connections are completed, operate the actuator and check that it functions correctly, that the operation times meet the plant requirements and that there are no leakages in the hydraulic connections.

NOTICE

If necessary to mount components not in Biffi scope of supply, please check the accessories mounting hole details in the documents TN 1028 (for metric dimension) or TN 1028U (for imperial dimension).

2.6 Electrical Connections (If Any)

⚠ WARNING

Use components appropriate as for type, material and dimensions. The connections should be made by qualified staff. Before carrying out any operation, cut line power off

Safety provisions:

2006/95/EC:	Directive for low voltage equipment (until 19 April 2016) 2014/35/EU from 20 April 2016
2004/108/EC:	Directive for the electromagnetic compatibility (until 19 April 2016) 2014/30/EU from 20 April 2016
94/9/CE:	Directive and safety instructions for use in hazardous Area (until 19 April 2016) 2014/34/EU from 20 April 2016

Remove plastic plugs from cables entries

- Screw firmly the cable glands.
- Introduce connection cables.
- Make the connections in compliance with applicable wiring diagrams on the documentation supplied.
- Screw the cable gland.
- Replace the plastic plugs of unused entries with metal plugs.

Figure 10 Junction box on Control group (if foreseen)



2.7 Commissioning

WARNING

Check that values of electrical supply to the control group (if foreseen) are compatible with those on the plate on the junction box (Figure 10). Installation, commissioning and maintenance and repair works should be made by qualified staff.

Upon actuator commissioning please carry out the following checks:

- Check that paint is not be damaged during transport, if necessary repair the damages to paint coat.
- Check that the values of hydraulic supply available in the system are compatible with those reported on the identification plate of the actuator (Figure 1) and on the documentation supplied.
- Check that the feed voltage values of the electric components (solenoid valve coils, micro-switches, pressure switches, etc.) are compatible with those reported on the identification plate of the actuator (Figure 1).
- Check that the setting of the components of the actuator control unit (pressure regulator, pressure switches, flow control valves, etc.) meet the plant requirements.
- Carry out all kinds of operations and check their proper execution (Section 3.3).
- Check the absence of leakages in the cylinder and in hydraulic connections. If necessary tighten the nuts of the pipe-fittings.
- Check proper operation of all the due signalling (valve position, supply pressure etc.).
- Make a complete functional test in order to verify all the operations are executed according to operating schematic diagram supplied.

Section 3: Operation and Use

3.1 Operation Description

In the normal operating situation, the double-acting actuator is fed by pressurised oil which flows into the relevant cylinder chamber (for example opening). The cylinder piston stroke causes the actuator operation and the consequent valve movement to the operational position requested (in this case to the “open” position).

Upon a demand, the closing chamber the cylinder is fed by pressurised oil and at the same time the oil is discharged from the open chamber into the return line: the actuator performs the closing operation driven by the piston movement, and the valve moves from the open position to the close (safety-related) position.

For local or remote operations, please refer to Sections 3.3.1, 3.3.2, and 3.3.3 and prior to technical documentation furnished with actuators.

Typical schematics for various applications are follow attached for information only.

The power and control systems are supplied on specific customer demand.

WARNING

For all the relevant information please refer to the specific technical documentation supplied with actuators.

Figure 11

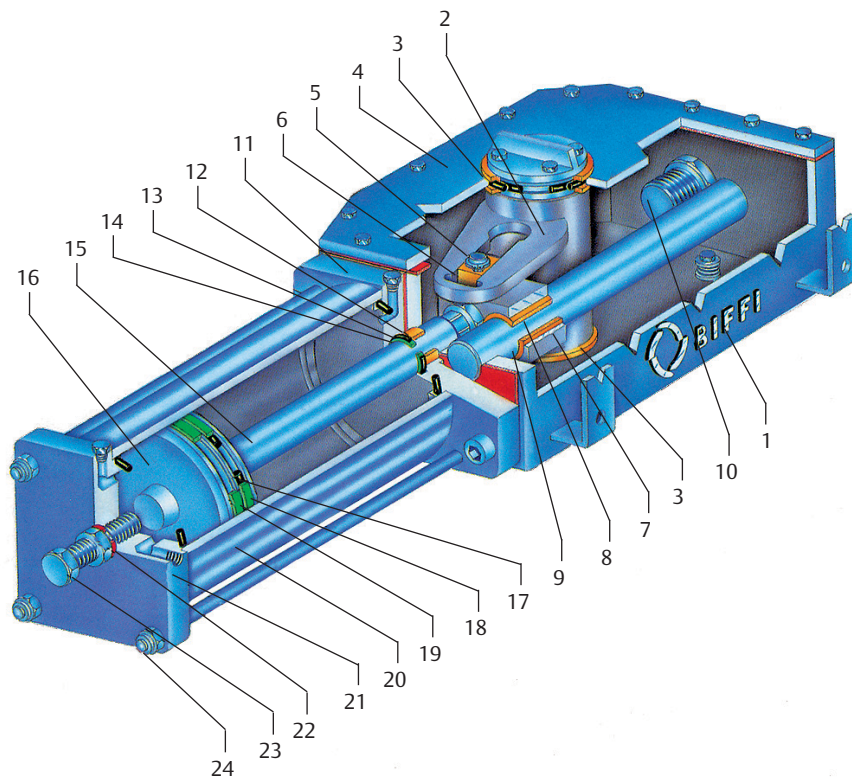

Table 3.

Item	Name
1	Housing
2	Yoke
3	Yoke bushing
4	Cover
5	Guide block pin
6	Sliding block
7	Guide block
8	Guide bar
9	Guide block bushing
10	Travel stop screw
11	Cylinder head flange
12	Piston rod bushing
13	Piston rod O-ring
14	Piston rod seal ring
15	Piston rod
16	Piston
17	Piston O-ring
18	Piston guide sliding ring
19	Piston seal ring
20	Cylinder tube
21	End flange
22	Sealing washer
23	Travel stop screw
24	Tie rod

3.2 Residual Risks

⚠ WARNING

The actuator has parts under pressure.
Use the due caution.
Use individual protections provided for by the laws and provisions in force.

3.3 Operations

Refer to specific document: Operating Diagram Furnished.

3.3.1 Local Manual Operation

The OLGA actuators can only have the hydraulic manual override for local operation.
The compact hydraulic control unit mounted on the actuator consist of:

- handpump
- directional control valve to select “to open” or “to close” actuator operation
- relief valve to prevent the oil pressure delivered by the handpump from exceeding the maximum allowable value
- oil tank

Accessory are available on request, for instance:

- dual pilot operated check valve
- bladder-type or piston-type accumulator delivered

Figure 12

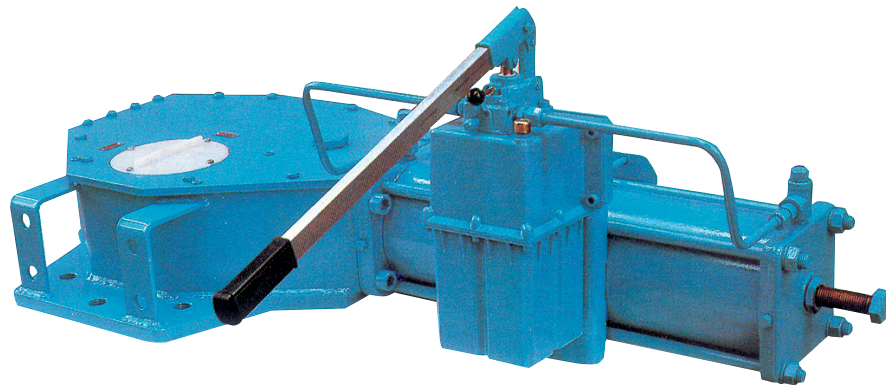

Figure 13

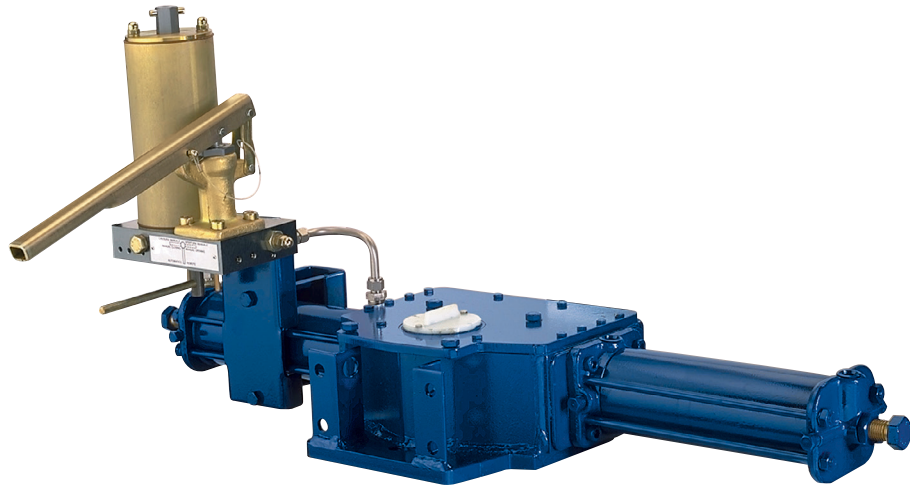

Figure 14 OLGA with hydraulic manual hand-pump

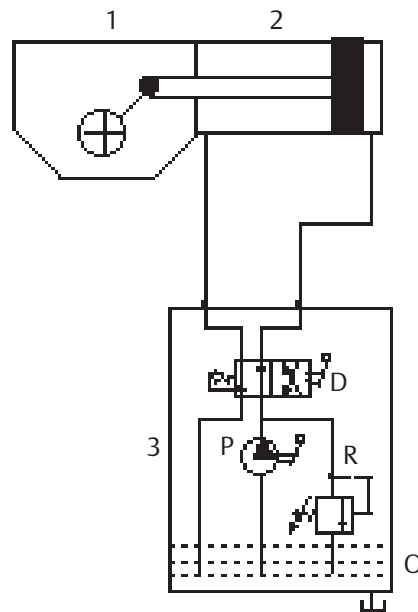

Table 4.

Item	Name
1	Scotch yoke mechanism
2	Hydraulic cylinder
3	Hydraulic manual override
D	Directional control valve
P	Handpump
R	Relief valve
O	Oil tank

3.3.2 Emergency Manual Operation by MHP

The OPGA actuators can have an emergency manual override in addition to the local and/or remote control panel which controls the oil supplied by a power pack for the “normal” actuator operation. The emergency manual override, mounted on the actuator, consists of a hydraulic manual override and a hydraulic manual selector to choose actuator “Normal operation” with oil supply from a power pack, or the “Emergency manual operation”.

The compact hydraulic override consist of:

- handpump
- directional control valve to select the “to open” or “to close” operation by handpump
- relief valve to prevent the oil pressure delivered by the handpump from exceeding the maximum allowable value

On request the emergency manual override can be included in the power pack.

Figure 15

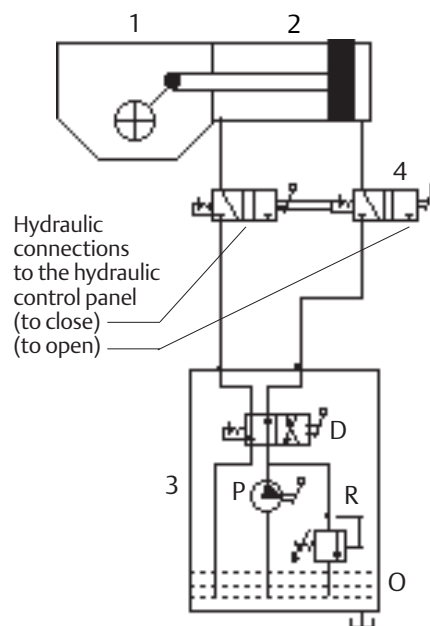

Table 5.

Item	Name
1	Scotch yoke mechanism
2	Hydraulic cylinder
3	Hydraulic manual override
4	Hydraulic manual selector
D	Directional control valve
P	Handpump
R	Relief valve
O	Oil tank

3.3.3 Emergency Manual Operation by MSJ - MHW

The MSJ jackscrew manual override can be supplied for OLGA actuators **from model 0.3 to model 3**. The override is mounted on the left side of the actuator, the jackscrew end is screwed into the guide block. A bronze split screw nut is mounted inside the body. By rotating the engagement lever, the screw nut is engaged with the jackscrew. When the screw nut is engaged with the jackscrew manual operation follows by rotating the body of the screw container by a lever. The manual jackscrew, on request, could be furnished with fixed handwheel welded on it.

Figure 16

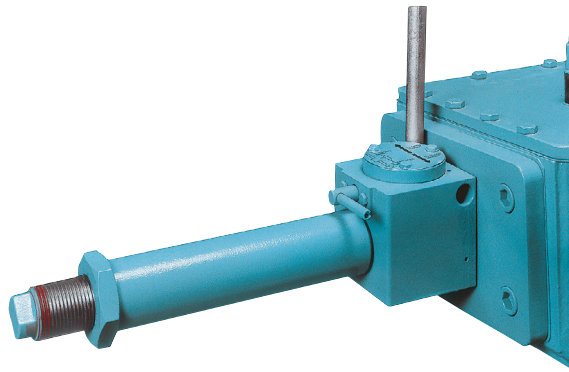

3.4 Calibration of the Angular Stroke

The angular stroke of the yoke can be adjusted between $82^{\circ} \div 98^{\circ}$ ($\pm 4^{\circ}$ with respect to the nominal positions of complete opening and closing) by means the mechanical stops screwed into the left side of the housing (open valve) and into the end flange of the hydraulic cylinder (closing) (Figure 17).

Figure 17 Mechanical Stops



In case of an actuator with two cylinders (Figure 18), both mechanical stops are screwed on the end flanges of the cylinders.

Figure 18 Actuator with two cylinders



For the adjustment of the mechanical stop on the end flange of cylinder, follow these steps (Figure 18):

- Remove with the specific wrench (c1) the plug (t).
- Insert a wrench for Allen keys (c2) in the through hole until reaching the adjustment pin (g).
- Keep the protection cover blocked with the special wrench (c3).
- Turn counterclockwise to increase the angular stroke, turn clockwise to decrease it.
- When the adjustment is over tighten the plug (t).

Figure 19

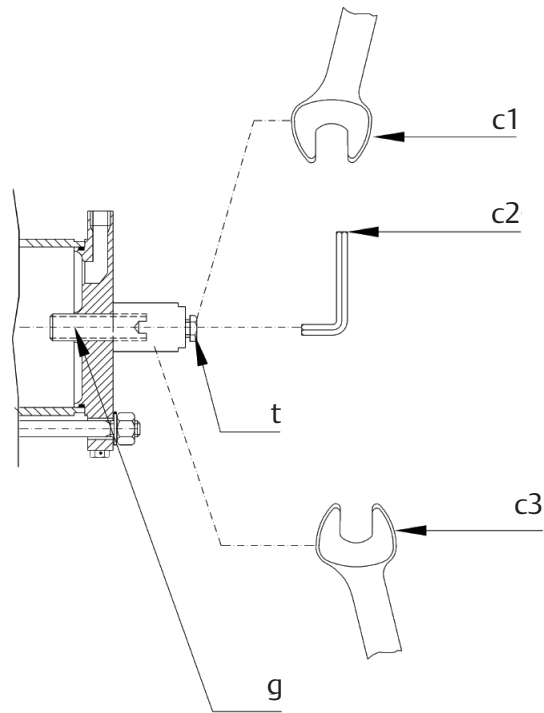

Table 6.

Hydraulic cylinder size	Wrench c1 (mm)	Wrench c2 (mm)	Wrench c3 (mm)
075	22	10	36
100	22	10	36
135	22	10	36
175	22	14	46
200	27	14	46
235	27	17	65
280	27	17	65
300	36	17	110

For the adjustment of the mechanical stop screwed into the left side of housing, follow these steps (Figure 20 and Figure 21):

- Loosen the locknut (d) with the specific wrench (c2).
- Adjust the pin (g)/screw (v) with the adequate wrench (c1).
- Turn counterclockwise to increase the angular stroke, turn clockwise to decrease it.
- When the adjustment is over tighten the locknut (d).

Figure 20 Mechanical stop on the housing

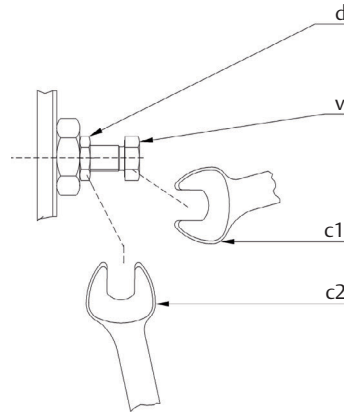

Table 7.

Hydraulic cylinder size	Wrench c1 (mm)	Wrench c2 (mm)
0,3	30	30
0,9	30	30
1,5	41	41
3	41	41
6	46	46

Figure 21 Mechanical stop on the housing

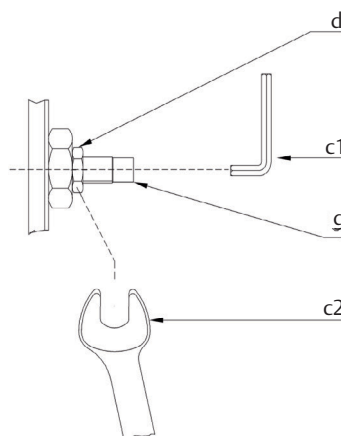

Table 8. Mechanical stop on the housing

Hydraulic cylinder size	Wrench c1 (mm)	Wrench c2 (mm)
14	17	60
18	17	60
32	17	60
50	17	60

For the adjustment of the mechanical stop screwed on the end flange of manual override (see Section 7.2, Figure 36).

Figure 22

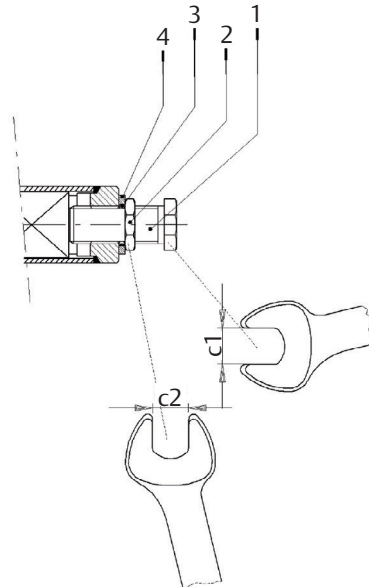

Table 9. Mechanical stop on the end flange of manual override

Hydraulic cylinder size	Wrench c1 (mm)	Wrench c2 (mm)
0,3	34	34
0,9	34	34

Figure 23

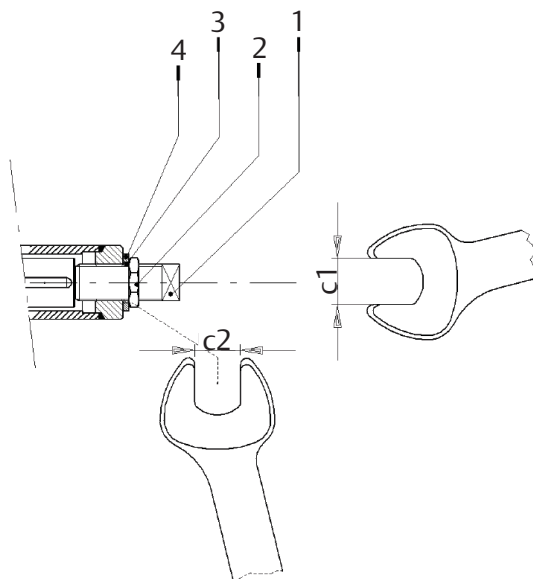

Table 10. Mechanical stop on the end flange of manual override

Hydraulic cylinder size	Wrench c1 (mm)	Wrench c2 (mm)
1,5	24	65
3	24	65

3.5 Calibration of Micro-switches (If Foreseen)

(Refer to Safety Instructions Manual for limit switch box).

WARNING

Refer only to technical documentation related to installed switch-box model.

NOTICE

For mounting interface dimension of the Limit Switch box on the cover of the actuator, please refer to TN1163V (for metric dimension) or TN1163VU (for imperial dimension).

NOTICE

Operate only the micro-switch corresponding to the direction of operation being carried out, as clearly reported on the micro-switch. End of stroke microswitches should be operated before the stop of the stroke of the actuator due to mechanical stops. Adjust the relative cams properly.

3.6 Calibration of the Operation Time (Optional – If Foreseen)

The calibration of the operation time is made by Biffi Italia s.r.l according to customer requirements and to technical data-sheet included in technical documentation. If necessary it's possible to modify or reset the operating time through two flow regulation valves (optional) placed on inlets of hydraulic cylinder (see Figure 24 and the applicable operating diagram).

Figure 24 Example of operating time adjustment (if foreseen)

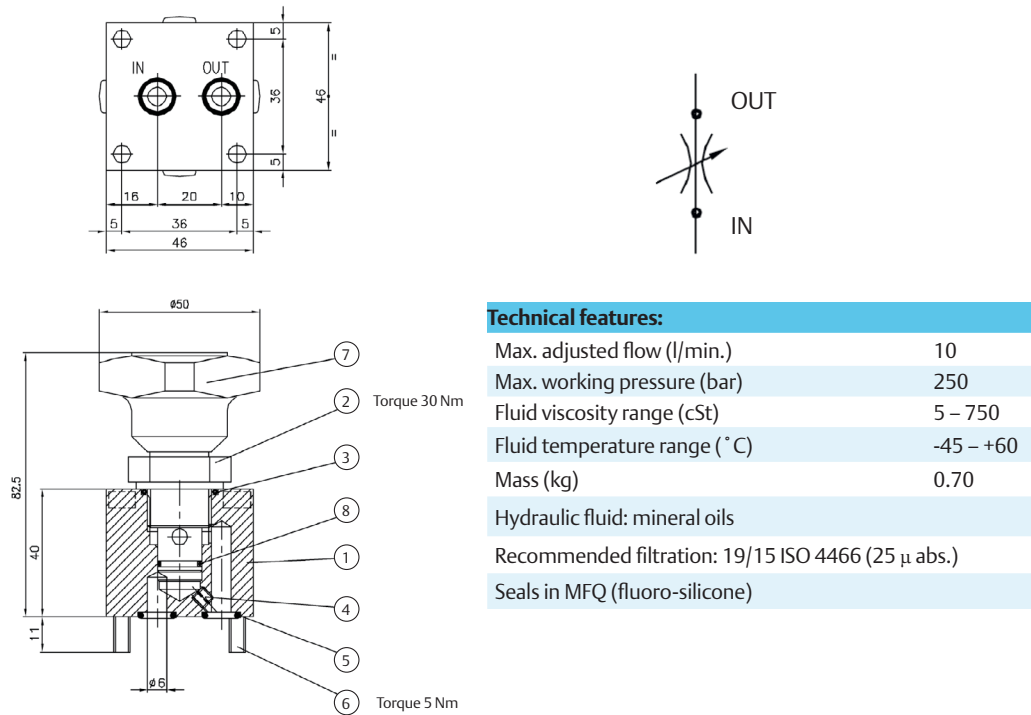

Table 11. Parts Lists

Item	Qty	Name	Material	Type or drawing
1	1	Body	AISI 316	49.144.031
2	1	Cartridge	AISI 316	FT 2267/2-14-hFQSV
3 *	1	O-ring	MFQ-70Sh	OR 2-116
4	1	Screw	A4-70	M5x5 UNI 5923
5	2	O-ring	MFQ-70Sh	OR 5-612
6	4	Screw	A4-70	VCTEI M5x45 UNI 5931
7	1	Handwheel	11S (2011)	29.102.378
8 *	1	OR+2BK	MFQ-6Sh+PTFE	OR2-013 + 2BK

* included in cartridge item 2

To carry out the adjustment, operate the handwheel (turn clockwise the handwheel to increase the operating time or turn the handwheel counterclockwise to decrease the operation time).

For OLGA actuator with Manual Handpump, the operating time is adjustable through two regulation valves placed on manual handpump body (see Section 7.2, Figure 35).

To carry out the adjustment, use an adequate Allen wrench and follow these steps (Figure 25):

- Remove the cap nut.
- Loosen the locknut.
- Screw with a screwdriver the setting screw to increase the operation time.
- Unscrew with a screwdriver the setting screw to decrease the operation time.
- After the adjustment is over screw the locknut and put back in place the cap nut.

Figure 25 Flow regulators placed on Manual Handpump

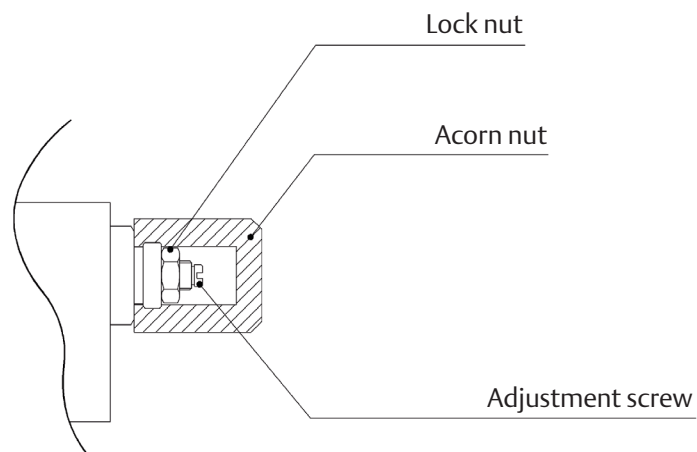

Section 4: Operational Tests and Inspections

NOTICE

To ensure the guaranteed SIL grade, according to IEC 61508, the functionality of actuator must be checked with regular intervals of time, as described in the Safety Manual.

Section 5: Maintenance

NOTICE

Before carrying out any maintenance operation, it is necessary to close the hydraulic feed line and exhaust the pressure from the actuator cylinder and from the control unit, to ensure safety of maintenance staff.

⚠ WARNING

Installation, commissioning and maintenance and repair works should be carried out by qualified staff.

5.1 Periodic Maintenance

OLGA actuators are designed to operate long-term in heavy-duty operating conditions, without maintenance needs.

NOTICE

Periodicity and regularity of inspections is particularly influenced by specific environmental and working conditions.

⚠ WARNING

They can be initially determined experimentally and then be improved according to actual maintenance conditions and needs.

Anyway every **2 years** of operation the following is recommended:

- Check that the actuator operates the valve correctly and with the required operating times. If the actuator operation is very infrequent, carry out a few opening and closing operations with all the existing controls (remote control, local control, emergency controls, etc.), if this is allowed by the conditions of the plant.
- Check there are no hydraulic leakages. If necessary tighten the nuts of the pipe-fittings.
- Check oil level (Figure 26) into the hydraulic control unit (see Section 5.1.1).
- Check the actuators did not undergo accidental damage with oil leakages found on site (Section 5.1.1).
- Check that improper closing of control-group cover (if present) did not produce the presence of condensation on it.
- Check the integrity of worn out parts (gaskets, pads etc.).
- If there is an oil filter on the actuator, bleed the condense water accumulated in the cup by opening the drain cock. Disassemble the cup periodically and wash it with soap and water; disassemble the filter: if this is made up of a sintered cartridge, wash it with nitrate solvent and blow through with oil. If the filter is made of cellulose, it must be replaced when clogged.

Figure 26 Level measuring stick



5.1.1 Check and Restore Oil Level in the Hydraulic Control Unit

Operate the distributor lever to “closing manual operation”.

Figure 27

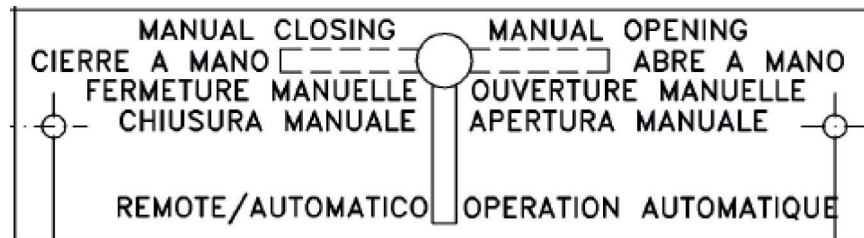

Move the actuator into his “fail to close” position.

Unscrew the dipstick (1).

Check that the oil level into the tank (4) is in correspondence of the “MAX LEVEL” notch of the dipstick.

Screw and tighten the dipstick.

If necessary substitute or added the oil, proceeding as follow:

- Remove the dipstick (1) from the tank cover (22).
- Unscrew the plug (27) and the washer (9) to drain all the oil.
- If some dirt or/and sludge is found in the oil drained from the tank, before filling with new oil in the tank, disassemble the oil tank tube, by unscrewing the two cap nuts (2), and clean the internal surfaces of the tank. If necessary substitute the gaskets (21) of the tank.
- Replace the plug (27) and the washer (9) into the plate (11) and tighten.
- Pour the new oil into the tank through the dipstick hole (1) on the cover (22).
- Replace the dipstick (1).
- Add oil (refer to Table 12) if in the tank the oil level is BELOW THE MINIMUM (Figure 26) until to reach the optimal (MAXIMUM) oil level.
- Operate the distributor lever to “Remote” position.

NOTICE

For refill use oil of the same brand as previous, refer to related technical documentation.

Table 12. Features of hydraulic oil suggested for refilling in different working conditions

Standard temperature conditions (-30 °C/+85°):	
Producer	AGIP
Name	ARNICA 22
Viscosity at 40 °C	20.9 mm ² /s
Viscosity at 100 °C	4.73 mm ² /s
Viscosity index ASTM	153
Flash point	192 °C
Pour point	-42 °C
Specific weight (at 15 °C)	0,857 kg/l
Equivalent oils	SHELL TELLUS PLUS 22 CHEVRON HYDRAULIC OIL AW ISO 22 MOBIL DTE22 EXXON UNIVIS N22 EQUIVIS ZS22 BP ENERGOL HLP-HM22 CASTROL DYSPIIN AWS22
Low temperature conditions (until -46 °C):	
Manufacturer	SHELL
Name	AEROSHELL FLUID 41
Viscosity at -54 °C	2300 cST
Viscosity at -40 °C	491 cST
Viscosity at 40 °C	14.1 cST
Viscosity at 100 °C	5.3 cST
Viscosity index (ISO 2909)	>200
Flash point	105 °C
Pour point	<-60 °C
Specific weight (Or equivalent)	0.87 kg/dm ³
Low temperature conditions (until -60 °C):	
Manufacturer	SYNTHESIS
Name	SYNTRASS-CS 500
Viscosity at -60 °C	580 cST
Viscosity at -30 °C	39 cST
Viscosity at 20 °C	5.8 cST
Viscosity at 50 °C	2.1 cST
Flash point	152 °C
Pour point	-68 °C
Specific weight (Or equivalent)	0.897 kg/dm ³

5.2 Extraordinary Maintenance

If there are leaks in the hydraulic cylinder, or a malfunction in the mechanical components, or in case of scheduled preventive maintenance, the actuator must be disassembled and seals must be replaced with reference to the follow general sectional drawing and adopting the following procedures.

5.2.1 Replacement of Cylinder Seals

Figure 28 Replacement of cylinder seals

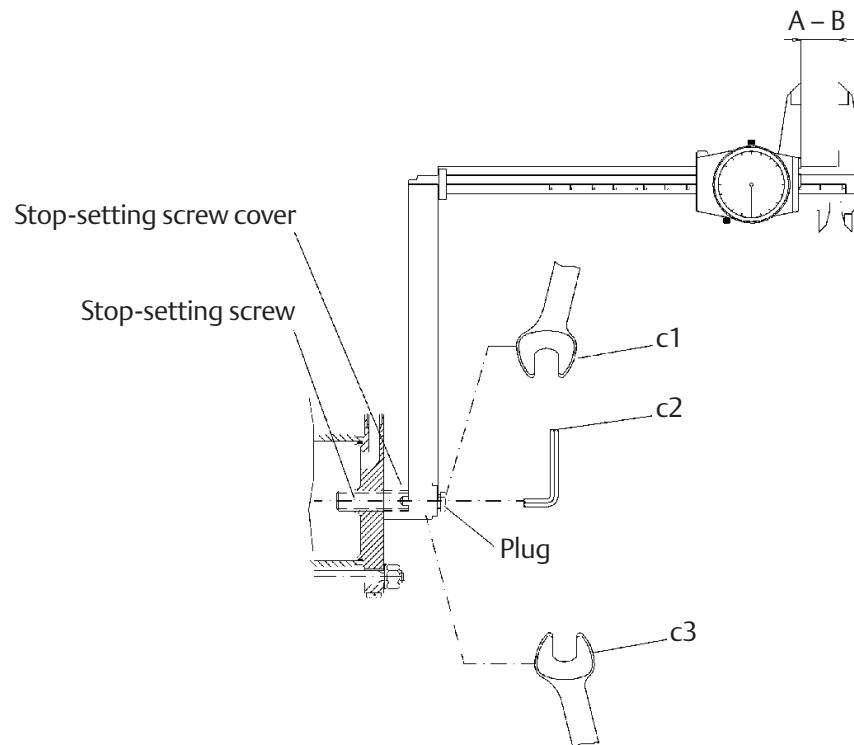

⚠ WARNING

Before executing any maintenance operation, it is necessary to intercept the supply line and discharge pressure from the cylinder of the actuator.

1. Unscrew the stop-setting screw cover (23) from the cylinder end flange.
2. Measure the distance of the stop screw (20) with reference to the end flange (22) surface, so as to be able to easily restore the setting of the actuator mechanical stop, once the maintenance procedures have been completed.
3. Unscrew the stop screw (20) by turning it anticlockwise with an Allen wrench until the screw is completely with drawn inside the end flange threaded hole.
4. Unscrew the nuts (25) from the tie rods (18): they must be gradually unscrewed all at the same time.
5. Slide off the end flange (22) and the tube (21).

6. If the actuator control unit requires the cylinder chamber head flange side to be also filled with oil, and the piston rod seal ring (40) to be replaced, remove the screw (2) and the cover (1). Unscrew the piston rod (17) threaded end from the adaptor bush (30) of the guide block (14). Slide off the piston rod (17) from the head flange (42).
7. Disassemble the head flange (42) from the mechanism housing (8) by removing the screws (31) only if the gaskets (37) and (39) have to be replaced because damaged.

Seals replacement

Prior to reassemble check that the actuator components are in good conditions and clean. Lubricate all the surfaces of the parts, which move in contact with other components, by recommended grease (AGIP-ENI LCX 2/32 if seals are in NBR/Viton or Neoprene rubber, or with Aeroshell Grease 7 if the seals are in Fluorosilicon rubber). If the O-ring must be replaced, remove the existing one from its groove, clean the groove carefully and lubricate it with protective grease film. Assemble the new O-ring into its groove and lubricate it with a protective grease film.

1. Replace the O-ring (43) of the head flange (42).
2. Replace the O-ring (43) of the end flange (22).

To replace the piston rod seal rings (40) proceed as follows:

1. Remove the existing Teflon seal ring (40) with its O-ring from their groove.
2. Clean the groove carefully and lubricate it with a protective oil film.
3. Assemble the new O-ring into its groove and lubricate it with a protective oil film.
4. Assemble the new Teflon seal ring (40) into the flange groove, inside its rubber O-ring, by bending it: take care that the bending radius is as large as possible to avoid damaged the seal. Then enlarge the seal ring with your fingers so as to restore its round shape: pay attention not to utilise any tools, which can damage the seal ring.

To replace the piston seal ring (46) proceed as follows:

1. Remove the existing Teflon seal ring (46) with its O-ring from their groove.
2. Clean the groove carefully and lubricate it with a protective oil film.
3. Assemble the new O-ring into its groove and lubricate it with a protective oil film.
4. Assemble the new Teflon seal ring (46) on its rubber O-ring by introducing one side of it into the groove, then enlarge it with your fingers so as to fit it into the groove: take care to enlarge it uniformly without any tools which could possibly damage it. The elastic memory of the kind of Teflon the seal ring is made of allows the ring to shrink back to its previous dimension after a short time.

Reassemble:

1. Assemble the new gasket (37-39) after cleaning the surfaces of housing (8), the flange (38) and head flange (42), which are in contact.
2. Assemble the head flange (42), replace the washers if damaged, tighten the screws (31) to the recommended torque.
3. Lubricate the piston rod (17) surface, with a protective oil film and introduce it into the head flange hole, taking care not to damage the O-ring (39). Carefully clean the threaded end of the piston rod (17) and the threaded hole of the adaptor bush (30) of guide block (14). Spread some sealant LOCTITE 452, or equivalent, on the rod threaded end and tighten.
4. Carefully clean the inside of the tube (21) and check that the entire surface, particularly that of the bevels, is not damaged. Lubricate with a protective oil film the tube internal surface and the bevels at the ends. Slide the tube onto the piston taking care not to damage the Teflon seal ring (46): the tube bevel has to smoothly compress the seal ring; take care also not to damage the head flange O-ring (43).
5. Assemble the end flange by centring it on the inside diameter of the tube, taking care not to damage the O-ring (43).
6. Assemble the nuts (25) onto the tie rods (18). Tighten the nuts to the recommended torque, alternating between opposite corners.
7. Restore a generous coating of grease on the contact surfaces of the yoke (11) and the bushings (33), on the yoke grooves, on the sliding blocks (5), on guide bar (9).
8. Assemble the new gasket (10) after cleaning the surfaces of the housing (8) and cover (1).
9. Lubricate with protective oil or grease the O-ring (32).
10. Assemble the cover (1) and the screws (2). Tighten the screws to the recommended torque.
11. Screw the stop screw (20) by turning it clockwise with an Allen wrench until it reaches its original position (the same distance with reference to the end flange surface).
12. Screw the stop-setting screw cover (23) into the cylinder end flange.

NOTICE

After maintenance operations carry out a few actuator operations to check that its movement is regular and that there is no oil leakage through the seals.

Figure 29 OLGA Double-Acting Hydraulic Actuator

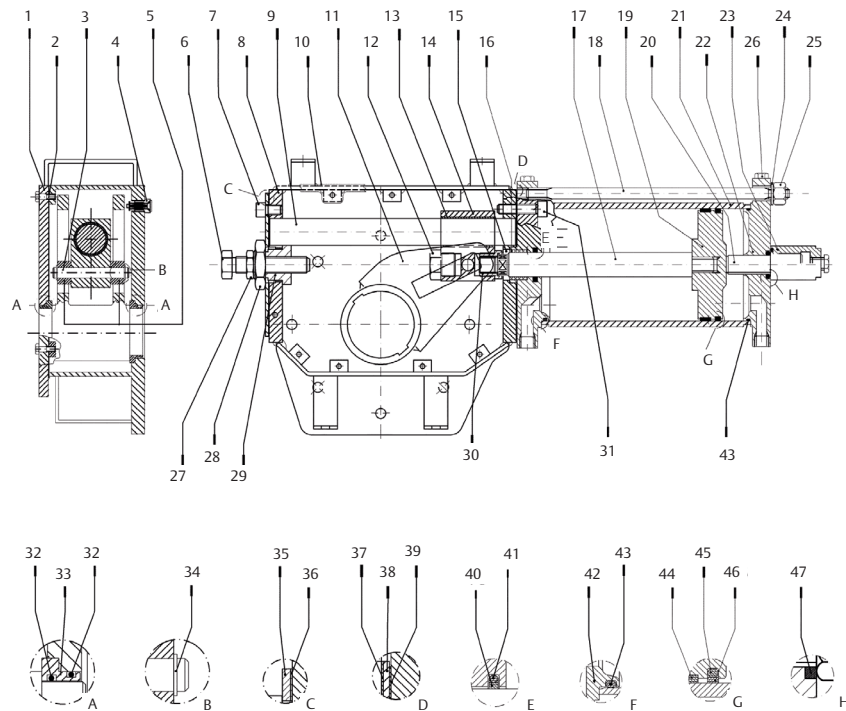

Table 13. Parts list

Item	Description	Item	Description
1	Cover	26	Plug
2	Screw	27	Nut
3	Guide block pin	28	Nut
4	Vent valve	29	Stopper bush
5	Sliding block	30	Adaptor bush
6	Screw	31	Screw
7	Screw	32	O-ring
8	Housing	33	Yoke bushing
9	Guide bar	34	Retainer ring
10	Cover gasket	35	Flange
11	Yoke	36	Gasket
12	Plug	37	Gasket
13	Bushing	38	Flange
14	Guide block	39	Gasket
15	Washer	40	Piston rod seal ring
16	Piston rod bushing	41	O-ring
17	Piston rod	42	Head flange
18	Tie rod	43	O-ring
19	Piston	44	Guide sliding ring for piston
20	Stop-setting screw	45	O-ring
21	Cylinder tube	46	Piston seal ring
22	End flange	47	Sealing washer
23	Stop-setting screw cover		
24	Spring washer		
25	Nut		

5.3 Lubrication of Mechanism

For normal duty the scotch yoke mechanism of the actuator is lubricated "for life". In case of high load and high frequency of operation it may be necessary to periodically restore lubrication: it is advisable to apply a generous coating of grease on the contact surfaces of the yoke and bushings, on the yoke link grooves, on the sliding blocks, on the guide bar.

For this operation it is necessary to disassemble the mechanism cover. In larger actuators the lubrication can be performed through the inspection holes of the cover after removing the plugs.

The following grease is used by BIFFI for standard working temperature and suggested for relubrication:

Table 14.

AGIP MU/EP2	AEROSHELL GREASE 7 or equivalent
To be used in standard temperature conditions (-30 °C/+85 °C)	To be used in standard temperature conditions (-30 °C/+85 °C)
NLGI consistency: 2	Color: Buff
Worked penetration: 280 dmm	Physical state: Semi-solid at ambient temperature
ASTM Dropping Point: 185 °C	Odor: Slight
Base oil viscosity at 40 °C: 160 mm ² /s	Density: 966 Kg/m ³ at 15 °C
ISO Classification: L-X-BCHB 2	Flash Point: 215 °C (COC) (Based on synthetic oil)
DIN 51 825: KP2K – 20	Dropping point: 260 °C (ASTM D-566)
Equivalent to:	Product code: 001A0065
ESSO BEACON EP2 BP GREASE LTX2 SHELL ALVANIA GREASE R2 ARAL ARALUB HL2 CHEVRON DURALITH GREASE EP2 CHEVRON SPHEEROL AP2 TEXACO MULTIFAK EP2 MOBILPLEX 47 PETROMIN GREASE EP2	Infosafe No.: ACISO GB/eng/C

5.4 Dismantling and Demolition

Before starting the disassembly a large area should be created around the actuator so to allow any kind of movement without problems of further risks created by worksite.

WARNING

Before disassembling the actuator it is necessary to close the hydraulic feed line and discharge oil pressure from the cylinder of the actuator, from the control unit and from the accumulator tank, if present.

If actuator is still mounted onto the valve, loosen the threaded connections between valve and actuator (screws, tie rods, nuts).

Lift the actuator using the proper lifting points, see Section 2.2.

If the actuator needs storage, before demolition, see Section 2.3.

WARNING

The demolition of the actuator both concerning any electrical and mechanical parts should be made by specialized staff.

Separate the parts composing the actuator according to their nature (ex. metallic, and plastic materials, fluids etc.) and send them to differentiate waste collection sites, as provided for by the laws and provisions in force.

Section 6: Troubleshooting

6.1 Failure or Breakdown Research

Table 15.

Event	Possible Cause	Remedy
Actuator does not work	Lack of power supply	Restore it
	Lack of hydraulic supply	Open line interception valve
	Blocked valve	Repair or replace
	Wrong position of the distributor of the manual hydraulic group	Restore correct position
	Failure of the control group	Call Biffi Italia s.r.l. Customer Service
	Unexpected intervention of torque limit-device	Call Biffi Italia s.r.l. Customer Service
	Low supply pressure	Restore (Section 1.4)
Actuator too slow	Low supply pressure	Restore (Section 1.4)
	Wrong calibration of flow regulator valves	Restore (Section 3.6)
	Wear of the valve	Replace
Actuator too fast	High supply pressure	Restore (Section 1.4)
	Wrong calibration of flow regulator valves	Restore (Section 3.6)
Leakages on hydraulic or pneumatic circuits	Deterioration and/or damage to gaskets	Call Biffi Italia s.r.l. Customer Service
Incorrect position of the valve	Wrong adjustment of mechanical stops	Restore (Section 3.4)
	Wrong warning of micro-switches	Restore (Section 3.5)
Hydraulic manual pump does not work	Handle positioned on remote control Leakages on the check valve of the hydraulic control group	Reposition the operation indication handle to manual Call Biffi Italia s.r.l. Customer Service

Section 7: Layouts

7.1 Spare Parts Order

For spare parts order to the relevant Biffi office please make reference to Biffi order confirmation concerning all the supply, and serial number of the actuator (Section 1.2) for any specific spare part for a specific actuator model.

Please send every spare parts request to:

Biffi Italia s.r.l. – Spares Office

Tel.: +39 0523-944523

Fax: +39 0523-941885

E-mail: Biffispares@Emerson.com

Please specify:

1. Actuator model
2. Biffi acknowledgement
3. Spare parts code
4. Quantity
5. Transport condition
6. Involved people

7.2 Parts List for Maintenance and Replacing Procedure

Figure 30 Scotch Yoke Mechanism

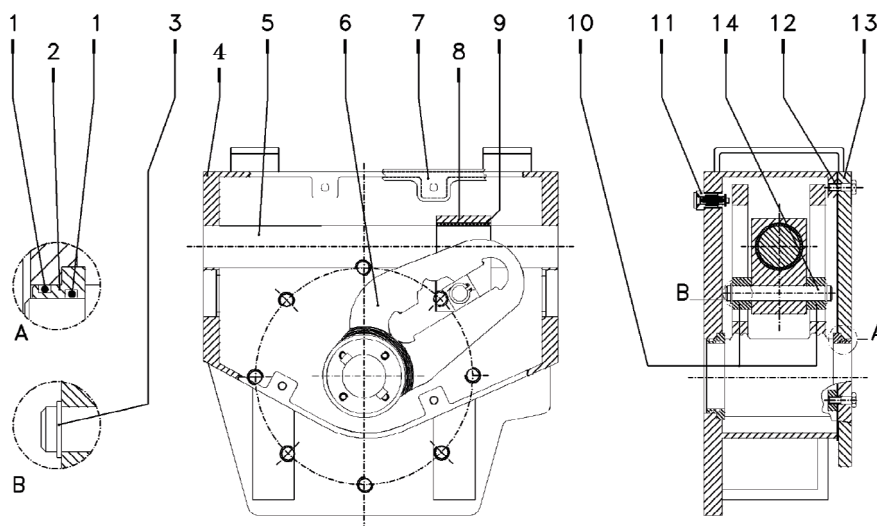

Table 16. Parts List

Item	Qty	Description	Material
1	4	O-ring	* NBR
2	2	Yoke bushing	Bronze
3	2	Retainer ring	Stainless steel
4	1	Housing	Carbon steel
5	1	Guide bar	Alloy steel
6	1	Yoke	Carbon steel
7	1	Cover gasket	* Fiber
8	1	Guide block	Carbon steel
9	1	Bushing	Steel + BZ + Teflon
10	2	Sliding block	Bronze
11	1	Vent valve	* Stainless steel
12	12	Screw	Carbon steel
13	1	Cover	Carbon steel
14	1	Guide block pin	Alloy steel

NOTE:

* Recommended spare parts

Figure 31 Hydraulic Cylinder

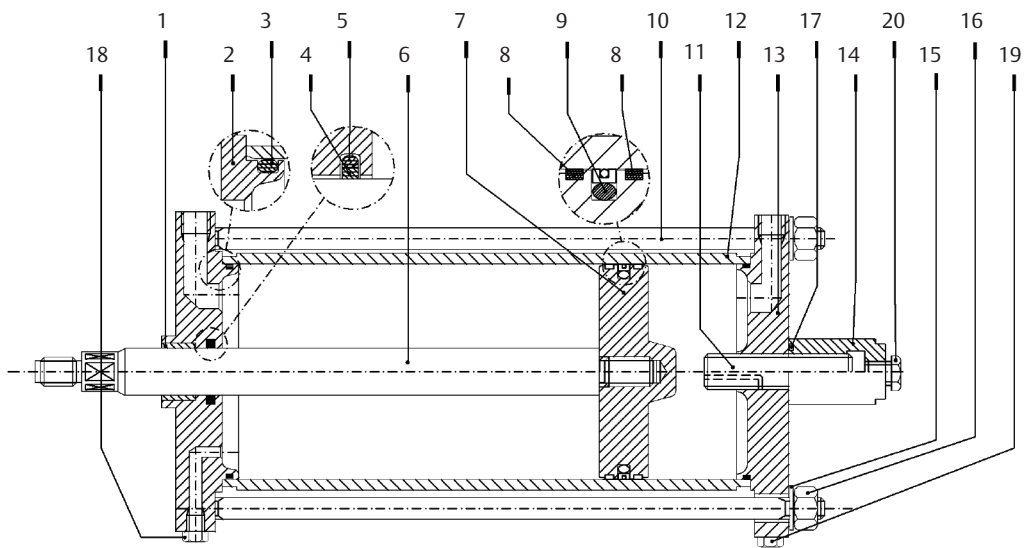

Table 17. Parts List

Item	Qty	Description	Material
1	1	Piston rod bushing	Steel + BZ + Teflon
2	1	Head flange	Carbon steel
3	2	O-ring	* NBR rubber
4	1	Piston rod seal ring	* Teflon + graphite
5	1	O-ring	* NBR rubber
6	1	Piston rod	Alloy steel
7	1	Piston	Nickel plated carbon steel
8	2	Guide sliding ring for piston	* Teflon + graphite
9	1	Piston seal ring	* Teflon + NBR
10	4	Tie rod	Alloy steel - ASTM A320 gr. L7
11	1	Stop-setting screw	Alloy steel
12	1	Cylinder tube	Nickel plated carbon steel
13	1	End flange	Carbon steel
14	1	Stop-setting screw cover	Carbon steel
15	4	Spring washer	Carbon steel
16	4	Nut	Carbon steel - ASTM A194 gr. 7
17	1	O-ring	* NBR rubber
18	6	Plug	Carbon steel
19	1	Plug	Carbon steel
20	1	Plug	Carbon steel

NOTE:

* Recommended spare parts

Figure 32 Hydraulic Cylinder for MHP (Optional)

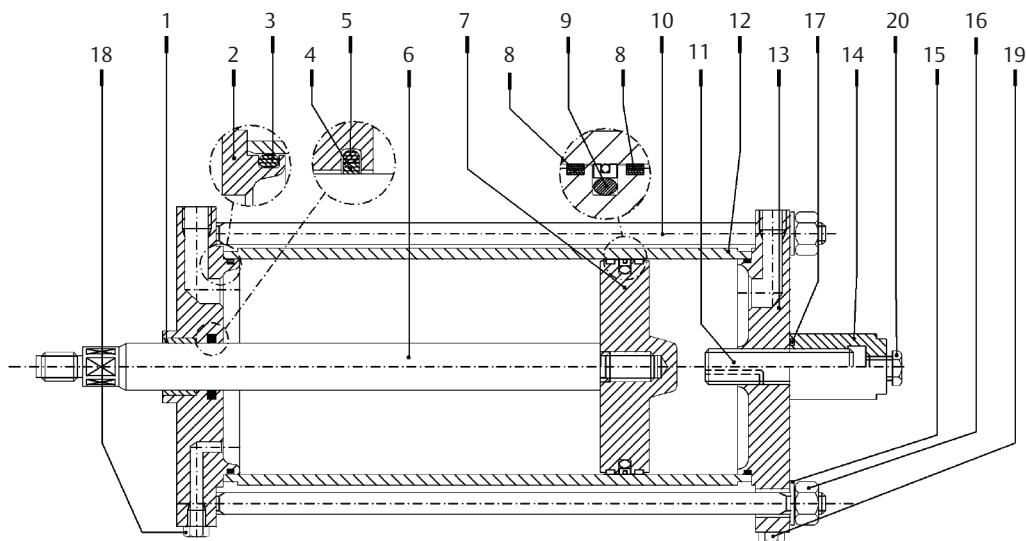

Table 18. Parts List

Item	Qty	Description	Material
1	1	Piston rod bushing	Steel + BZ + Teflon
2	1	Head flange	Carbon steel
3	2	O-ring	* NBR rubber
4	1	Piston rod seal ring	* Teflon + graphite
5	1	O-ring	* NBR rubber
6	1	Piston rod	Alloy steel
7	1	Piston	Nickel plated carbon steel
8	2	Guide sliding ring for piston	* Teflon + graphite
9	1	Piston seal ring	* Teflon + NBR
10	4	Tie rod	Alloy steel - ASTM A320 gr. L7
11	1	Stop-setting screw	Alloy steel
12	1	Cylinder tube	Nickel plated carbon steel
13	1	End flange	Carbon steel
14	1	Stop-setting screw cover	Carbon steel
15	4	Spring washer	Carbon steel
16	4	Nut	Carbon steel - ASTM A194 gr. 7
17	1	O-ring	* NBR rubber
18	6	Plug	Carbon steel
19	1	Plug	Carbon steel
20	1	Plug	Carbon steel

NOTE:

* Recommended spare parts

Figure 33 Assembly Kit

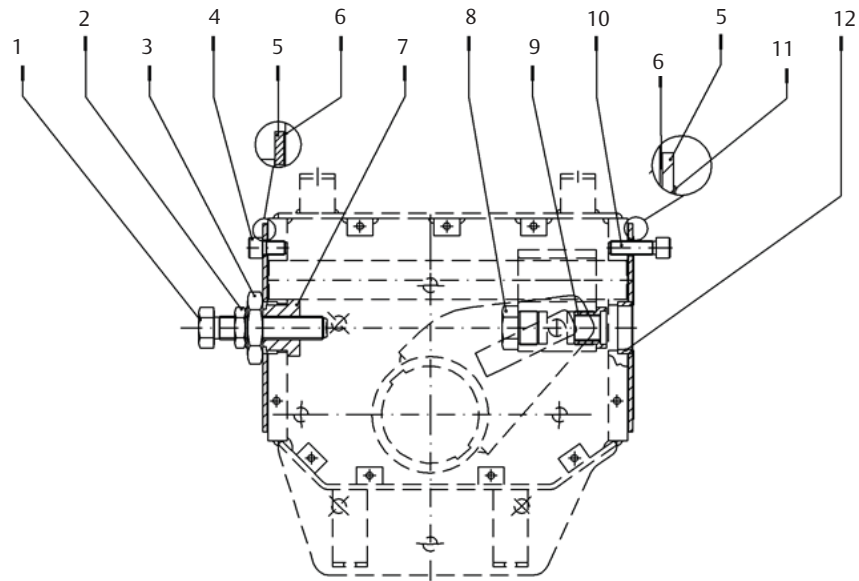

Table 19. Parts List

Item	Qty	Description	Material
1	1	Screw	Alloy Steel
2	1	Nut	Carbon steel
3	1	Nut	Carbon steel
4	4	Screw	Alloy Steel
5	2	Flange	Carbon steel
6	2	Gasket	* Fiber
7	1	Stopper bush	Alloy Steel
8	1	Plug	Alloy Steel
9	1	Adaptor bush	Alloy Steel
10	4	Screw	Alloy Steel
11	1	Gasket	* Fiber
12	1	Washer	Alloy Steel

NOTE:

* Recommended spare parts

Figure 34 Hydraulic Control Unit MHP

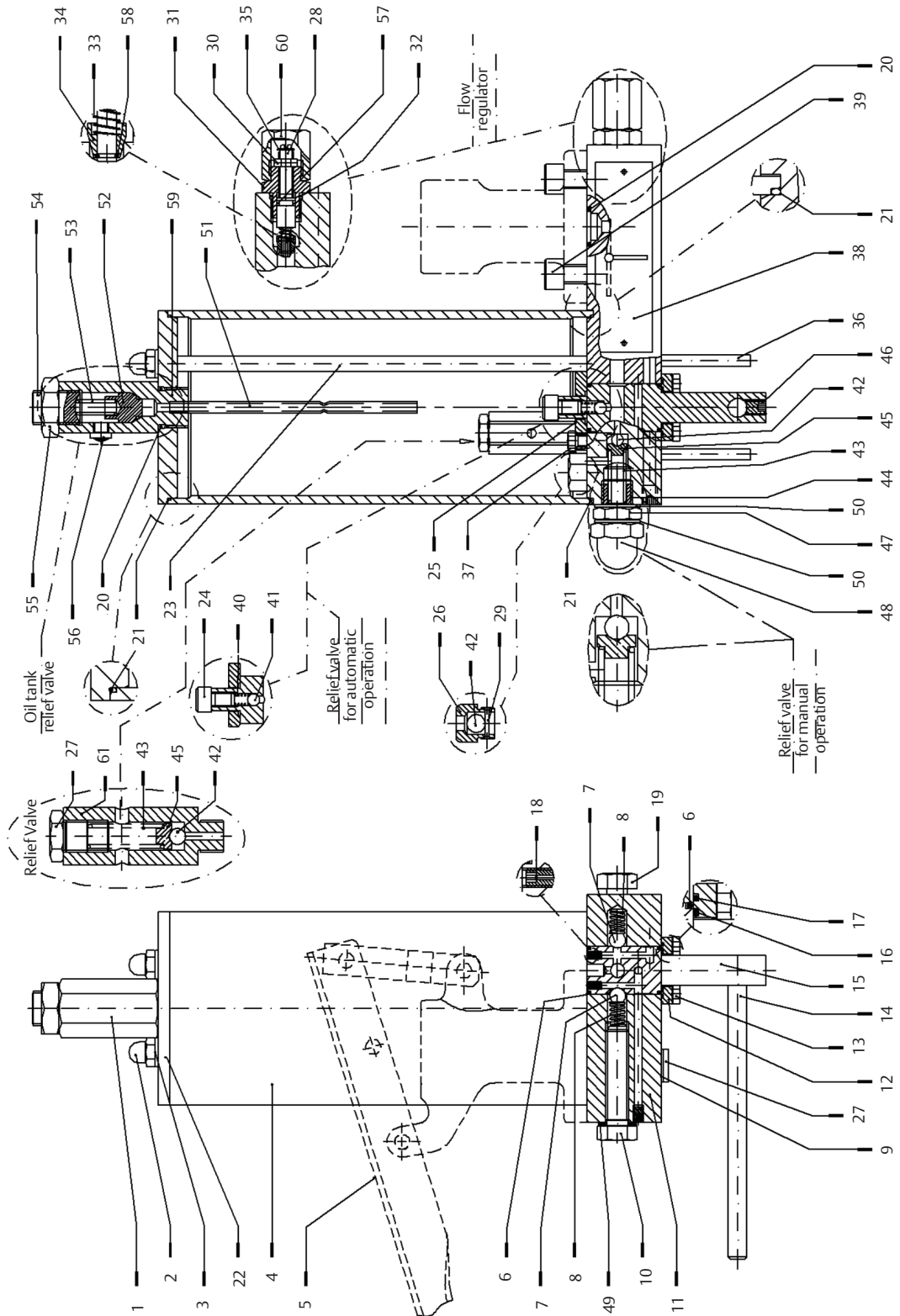

Table 20. Parts List

Item	Qty	Description	Material
1	1	Dipstick	-
2	2	Cap nut	Carbon steel
3	2	Washer	Carbon steel + rubber
4	1	Hydraulic tank	Carbon steel
5	1	Handpump	See attached table
6	2	O-ring	* Fluorosilicon rubber
7	2	Ball	Stainless steel
8	2	Spring	Spring steel
9	1	Washer	Carbon steel + rubber
10	1	Screw	Carbon steel
11	1	Plate	Carbon steel
12	1	Flange	Aluminium
13	4	Screw	Carbon steel
14	1	Lever	Carbon steel
15	1	Distributor	Stainless steel
16	1	O-ring	* Fluorosilicon rubber
17	1	O-ring	* Fluorosilicon rubber
18	1	Nozzle	Carbon steel
19	2	Screw	Carbon steel
20	3	O-ring	* Fluorosilicon rubber
21	2	O-ring	* Fluorosilicon rubber
22	1	Tank cover	Carbon steel
23	2	Tie rod	Carbon steel
24	1	Screw	Carbon steel
25	1	Flange	Aluminium
26	2	Check valve body	Aluminium
27	2	Plug	Carbon steel
28	2	Flow control valve setting screw	Stainless steel
29	2	Spring pin	Stainless steel
30	2	Nut	Carbon steel
31	2	Flange	Carbon steel
32*	2	O-ring	* Fluorosilicon rubber
33	2	Spring	Spring steel
34	2	Plug	Stainless steel
35	2	Retainer ring	Spring steel
36	2	Spring pin	Carbon steel
37	4	Screw	Carbon steel
38	1	Operation instruction plate	Stainless steel
39	4	Screw	Carbon steel
40	1	Spring	Stainless steel
41	1	Ball	Stainless steel
42	4	Ball	Stainless steel
43	2	Spring	Spring steel
44	1	Relief valve setting screw	Stainless steel
45	2	Spring pin	Carbon steel
46	1	Screw	Alloy steel
47	1	Spring	Stainless steel
48	1	Nut	Carbon steel
49	1	Washer	Carbon steel + rubber
50	2	Washer	Carbon steel + rubber
51	1	Dipstick	Stainless steel
52	1	Plug + O-ring	*
53	1	Spring	Stainless steel
54	1	Screw	Alloy steel
55	1	Nut	Carbon steel
56	1	Silencer	Brass
57	2	O-ring	* Fluorosilicon rubber
58	2	Retainer ring	Spring steel
59	1	Dipstick body	Aluminium
60	2	Nut	Carbon steel
61	1	Relief valve body	Aluminium

NOTE:

* Recommended spare parts

Figure 35 Handpump

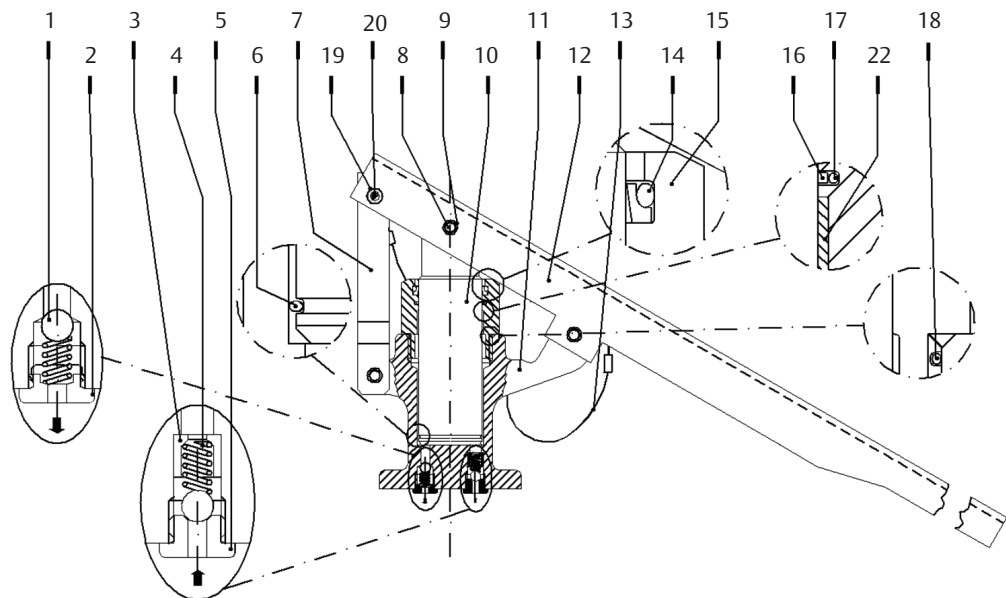

Table 21. Parts List

Item	Qty	Description	Material
1	2	Ball	Stainless steel
2	1	Delivery valve bush	Carbon steel
3	1	Suction valve bush	Carbon steel
4	2	Spring	Stainless steel
5	1	Suction valve ring	Carbon steel
6	1	Spring retainer ring	Carbon steel
7	1	Fork	Carbon steel
8	2	Pin	Stainless steel
9	4	Retainer ring	Carbon steel
10	1	Rod	Alloy steel
11	1	Body	Carbon steel
12	1	Lever	Carbon steel
13	1	Split pin with rope	Nylon + carbon steel
14	1	Scraper ring	* Teflon + fluorosilicon rubber
15	1	Threaded bush	Aluminium
16	2	Rod seal ring	* Teflon + graphite
17	2	O-ring	* Fluorosilicon rubber
18	1	O-ring	* Fluorosilicon rubber
19	1	Nut	Carbon steel
20	1	Screw	Carbon steel
21	1	Fork	Carbon steel
22	1	Piston rod bushing	Steel + BZ + PTFE

NOTE:

* Recommended spare parts

Figure 36 Jackscrew manual override MSJ

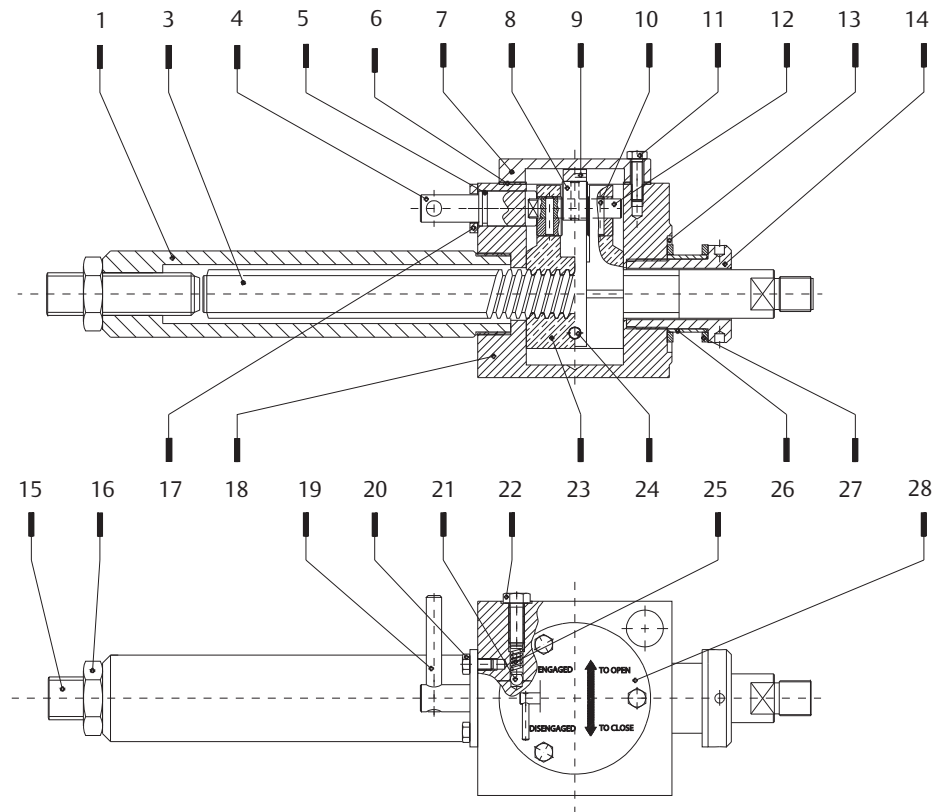

Table 22. Parts List

Item	Qty	Description	Material
1	1	Protection pipe	Carbon steel
3	1	Jackscrew	Carbon steel
4	1	Engagement lever pin	Stainless steel
5	1	O-ring	* Fluorosilicon rubber
6	1	Cover gasket	* Fiber
7	1	Cover	Carbon steel
8	3	Cam	Alloy steel
9	1	Fork	Carbon steel
10	3	Spring pin	Stainless steel
11	3	Screw	Carbon steel
12	1	Screw nut operating cam	Alloy steel
13	1	O-ring	* Fluorosilicon rubber
14	1	Thrust nut operating cam	Alloy steel
15	1	Screw	Carbon steel
16	1	Nut	Carbon steel
17	1	Flange	Carbon steel
18	1	Body	Carbon steel
19	1	Spring pin	Spring steel
20	2	Screw	Carbon steel
21	1	Ball 1/4"	Stainless steel
22	1	Screw	Carbon steel
23	1	Screw nut	Bronze
24	1	Pin	Carbon steel
25	1	Spring	Spring steel
26	1	Bush	Bronze
27	2	Thrust shoulder washer	Bronze
28	1	Operating instruction plate	Aluminium

NOTE:

* Recommended spare parts

Section 8: Date Report for Maintenance Operations

Last maintenance operation date:

(in factory, on delivery):

..... exec. by:

..... exec. by:

..... exec. by:

Next maintenance operation date:

..... exec. by:

..... exec. by:

..... exec. by:

Start-up date:

..... (in factory, on delivery)

..... (on plant)

Biffi Italia s.r.l.
Strada Biffi 165
29017 Fiorenzuola d'Arda (PC)
Italy
T +39 0523 944 411

For complete list of sales and manufacturing sites, please visit
www.biffi.it or contact us at biffi_italia@biffi.it

VCIOM-03399-EN ©2020 Biffi. All rights reserved.

The contents of this publication are presented for information purposes only, and while every effort has been made to ensure their accuracy, they are not to be construed as warranties or guarantees, express or implied, regarding the products or services described herein or their use or applicability. All sales are governed by our terms and conditions, which are available on request. We reserve the right to modify or improve the designs or specifications of our products at any time without notice.

