

# Biffi GIG

## Double-Acting Direct Gas Actuator

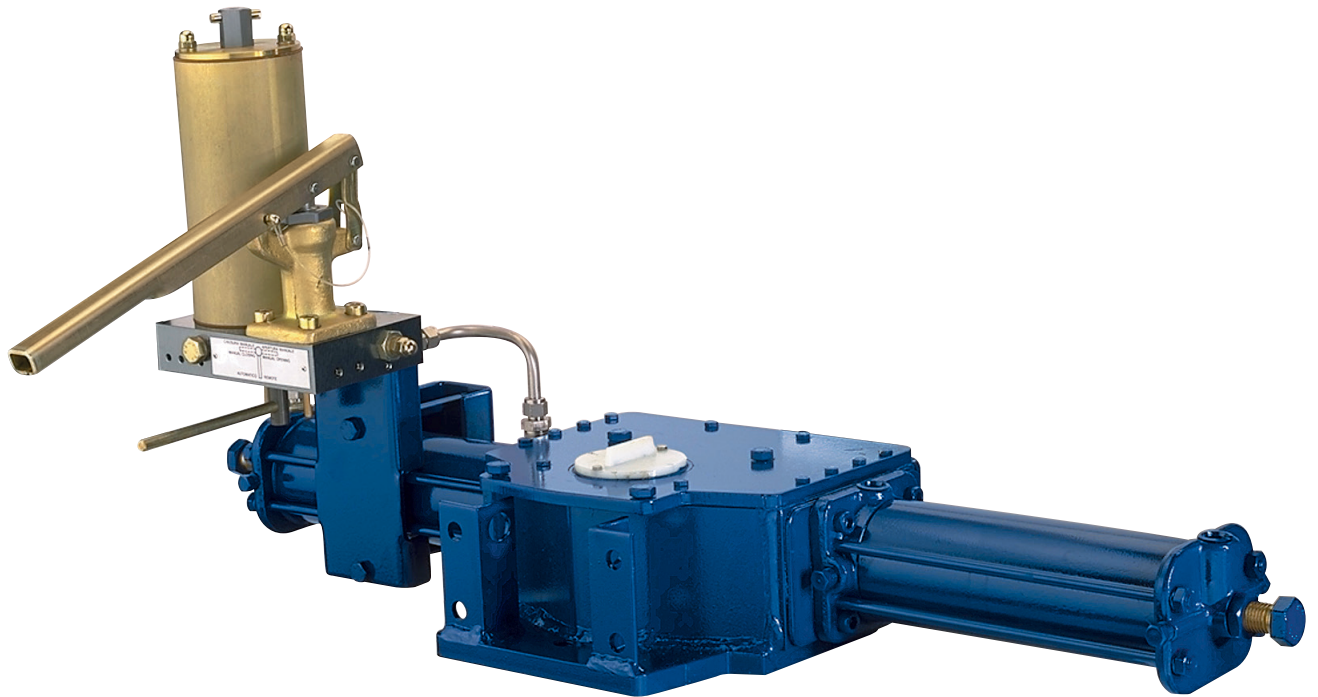

**Revision Details**

<b>Revision</b>	<b>Date</b>	<b>Description</b>	<b>Prepared</b>	<b>Checked</b>	<b>Approved</b>
1	August 2021	General update (Migration to new template)			
0	June 2016	Document release	Ermanni	Orefici	Vigliano

# Table of Contents

## Section 1: General Warnings

1.1	Generalities.....	1
1.1.1	Applicable Regulation .....	1
1.1.2	Terms and Conditions.....	2
1.1.3	Electrostatic Charge .....	2
1.2	Identification Plate .....	2
1.3	Introducing the Actuator.....	3
1.4	Data Sheet .....	3

## Section 2: Installation

2.1	Checks upon Actuator Receipt .....	4
2.2	Actuator Handling.....	4
2.3	Storage .....	6
2.4	Actuator Assembly on the Valve .....	6
2.4.1	Types of Assembly .....	6
2.4.2	Assembly Procedure.....	11
2.5	Pneumatic Connections .....	12
2.6	Electrical Connections (If Any).....	13
2.7	Commissioning.....	14

## Section 3: Operation and Use

3.1	Operation Description.....	15
3.2	Residual Risks.....	19
3.3	Operations.....	19
3.3.1	Local Pneumatic Operation .....	19
3.3.2	Electric Remote Control to Open and to Close .....	20
3.3.3	Emergency Manual Operation by MSJ / MHW .....	20
3.3.4	Emergency Manual Operation by MHP .....	22
3.4	Calibration of the Angular Stroke .....	25
3.5	Calibration of Microswitches (Biffi Limit Switch Box Only).....	30
3.6	Calibration of the Operation Time .....	33

## Section 4: Operational Tests and Inspections

Operational Tests and Inspections.....	35
--	----

## Section 5: Maintenance

5.1 Periodic Maintenance.....	36
5.1.1 Check and Restore Oil Level in the Hydraulic Manual Override .....	37
5.2 Extraordinary Maintenance .....	40
5.2.1 Replacement of Cylinder Seals .....	40
5.3 Dismantling and Demolition .....	44
5.4 Lubrication of Mechanism .....	45

## Section 6: Troubleshooting

6.1 Failure or Breakdown Research .....	46
---	----

## Section 7: Layouts

7.1 Spare Parts Order .....	47
7.2 Parts List for Maintenance and Replacing Procedure .....	48

## Section 8: Date Report for Maintenance Operations

Date Report for Maintenance Operations.....	55
---	----

## NOTICE

Biffi Italia s.r.l. pays the highest attention to collecting and verifying the documentation contained in this user manual. However, Biffi Italia s.r.l. is not liable for any mistakes contained in this manual, for damage or accidents due to the use of the latter. The information contained is of exclusive reserved ownership of Biffi Italia s.r.l. and may be modified without prior notice. All rights reserved.

# Section 1: General Warnings

## NOTICE

The manual is an integral part of the machine, it should be carefully read before carrying out any operation and it should be kept for future references.

## 1.1 Generalities

Biffi Italia s.r.l. actuators are conceived, manufactured and controlled according to the Quality Control System in compliance with EN ISO 9001 international regulation.

### 1.1.1 Applicable Regulation

<b>UNI EN ISO 12100-1: 2005:</b>	Safety of machinery – Basic notions, general design principles. Part 1-Basic terminology, method.
<b>UNI EN ISO 12100-2: 2005:</b>	Safety of machinery – Basic notions, general design principles. Part 2-Technical principles and specification.
<b>2006/42/EC:</b>	Machine directive
<b>97/23/EC:</b>	Directive for pressure PED equipment (until 18 July 2016) 2014/68/EU from 19 July 2016
<b>2006/95/EC:</b>	Directive for low voltage equipment (until 19 April 2016) 2014/35/EU from 20 April 2016
<b>2004/108/EC:</b>	Directive for the electromagnetic compatibility (until 19 April 2016) 2014/30/EU from 20 April 2016
<b>94/9/CE:</b>	Directive and safety instructions for use in hazardous area (until 19 April 2016) 2014/34/EU from 20 April 2016
<b>TR TS 010/2011</b>	Customs Union Technical Regulation (For safety of equipment and machines)

## 1.1.2 Terms and Conditions

Biffi Italia s.r.l. guarantees that all the items produced are free of defects in workmanship and manufacturing materials and meet relevant current specifications, provided they are installed, used and serviced according to the instructions contained in the present manual. The warranty can last either one year from the date of installation by the initial user of the product, or eighteen months from the date of shipment to the initial user, depending on which event occurs first. All detailed warranty conditions are specified in the documentation forwarded together with the product. This warranty does not cover special products or components not warranted by subcontractors, or materials that were used or installed improperly or were modified or repaired by unauthorized staff. In the event that a fault condition be caused by improper installation, maintenance or use, or by irregular working conditions, the repairs will be charged according to applicable fees.

**The warranty and Biffi Italia s.r.l. liability shall lapse in the event that any modification or tampering whatsoever be performed on the actuator.**

## 1.1.3 Electrostatic Charge

An electrostatic charge risk is present on the actuator surface; in case of cleaning, use only antistatic cloth; in case of maintenance, avoid all rubbing/frictions that could electrostatically charge the equipment.



## 1.2 Identification Plate

### **⚠ WARNING**

It is forbidden to modify the information and the marks without previous written authorization by Biffi Italia s.r.l.

The plate fastened on the actuator contains the following information (Figure 1).

**Figure 1 Data plate**

	BIFFI ITALIA Fiorenzuola D'Arda 29017 (PC) - ITALY	
ORDER _____	ACKNOW. _____ S/N _____	
MODEL _____	CONSTR. YEAR _____ FLUID _____	
ALLOWABLE TEMP. RANGE _____	MAX ALLOWABLE PRESSURE _____	
SUPPLY PRESSURE RANGE _____	VALVE TAG _____ ND _____	
	Reference IP66 NERS 16615,03 NERS 16616,03	NEMA 4,4X,6

## 1.3 Introducing the Actuator

The direct gas actuator GIG was engineered and is manufactured to provide fail-safe operation for any quarter-turn application such as ball, plug, butterfly valves or dampers, in both ON-OFF and Modulating heavy duty service.

The actuator (see Figure 2) is made up of a weatherproof scotch yoke mechanism transforming the linear movement of the pneumatic cylinder (on closing or opening) into the rotary movement, which is necessary for operation. The angular stroke of the yoke is adjustable between 82° and 98° by means of the external mechanical stops screwed into the left wall of the mechanism housing and into the end flange of the pneumatic cylinder. The cover of the scotch yoke mechanism is arranged for the assembly of the required accessories (positioner, signalling limit switches, position transducer, etc.) by means of proper matching units. The above mentioned accessories are operated by the actuator drive sleeve. The housing of the scotch yoke mechanism has a flange with threaded holes to fix the actuator to the valve either directly or, if required, with the interposition of an adaptor flange or a mounting bracket. The actuator yoke has a hole with keyways suitable for the assembly of an insert bush the internal hole of which is machined (by Biffi or at Customer's care), according to the shape and dimensions of the valve stem. Biffi can supply different types of control system following Customer's requirements.

The expected lifetime of actuator is approximately 25 years.

**Figure 2 Identification of actuator parts**

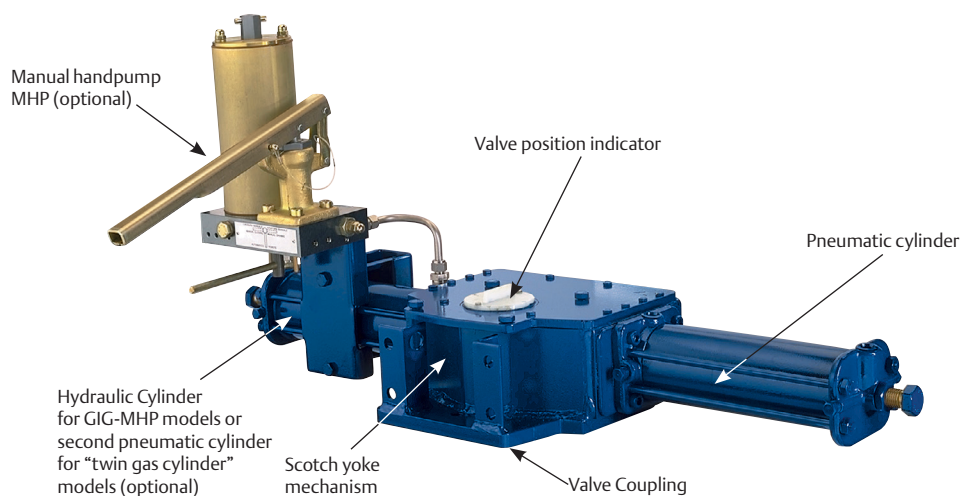

## 1.4 Data Sheet

Supply fluid	Sweet, dry natural gas; sour high pressure gas; nitrogen or instrument air
Operating temperature	Standard: from -30 °C to +100 °C Optional: from -60 °C to +140 °C
Supply pressure	Please refer to technical document: "actuator data sheet"

## Section 2: Installation

### 2.1 Checks upon Actuator Receipt

- Check that the model, the serial number of the actuator and the technical data reported on the identification plate correspond with those of order confirmation, see Section 1.2.
- Check that the actuator is equipped with the fittings as provided for by order confirmation.
- Check that the actuator was not damaged during transportation: if necessary, renovate the painting according to the specification reported on the order confirmation.
- If the actuator is received already assembled with the valve, its settings have already been made at the factory.
- If the actuator is delivered separately from the valve, it is necessary to check, and if required, to adjust the settings of the mechanical stops (Section 3.4) and of microswitches (if any) (Section 3.5).

### 2.2 Actuator Handling

#### NOTICE

The lifting and handling of the actuator must be done by qualified personnel and in accordance with the laws and regulations in force.

#### WARNING

The fastening points are appropriate for the lifting of the actuator alone and not for the valve+actuator assembly. Avoid that during the handling, the actuator passes above the staff. The actuator should be handled with appropriate lifting means. The weight of the actuator is reported on the delivery bill.

**Figure 3** Lifting points for GIG / GIG-MHP / GIG-MSJ / GIG-MHW actuators

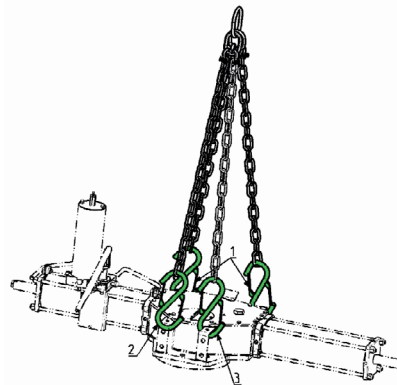

1-2 = Lifting points (obligatory)  
 3 = Balancing point

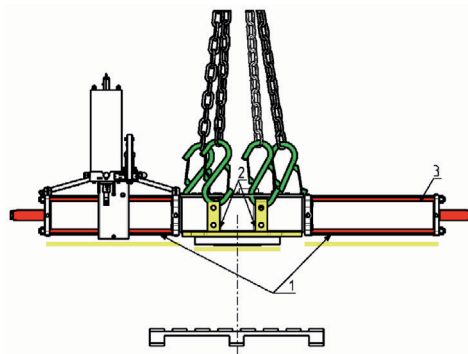

1 = point of support  
 2 = supports for lateral positioning

**⚠ WARNING**

3 = don't lay the actuator on tie rods of cylinder/s and don't lay the actuator on accessories (manual handpump, manual jackscrew, pneumatic control group etc.).

## 2.3 Storage

If the actuator needs storage, before installation follow these steps:

- Place it on a wood surface in order not to deteriorate the area of valve coupling.
- Make sure that plastic plugs are present on the pneumatic and electrical connections (if present).
- Check that the cover of the control group and of the limit switch box (if any) are properly closed.

If the storage is long-term or outdoor:

- Keep the actuator protected from direct weather conditions.
- Replace plastic plugs of pneumatic and electrical connections (if any) with metal plugs that guarantee perfect tightness.
- Coat with oil, grease or protection disc, the valve coupling area.
- Periodically operate the actuator (Section 3.3).

## 2.4 Actuator Assembly on the Valve

### 2.4.1 Types of Assembly

For coupling to the valve, the housing is provided with a flange with threaded holes according to Biffi standard tables (SCN6200; SCN6201;SCN6201-1). The number, dimensions and diameter of the holes are made in accordance with ISO 5211, but for actuator models 0.3 to 6 the holes are drilled on the centerline in order to allow an easier assembly of an intermediate flange, when required. This intermediate flange (or spool-piece ) can be supplied when the valve flange can not directly match the actuator flange in its “standard” configuration.

For the biggest actuator models, the actuator flange can be machined in accordance with the valve flange dimensions.

The yoke has bored with keyways for coupling to the valve stem, the dimensions of which are according to Biffi standard tables SCN6200 and SCN6201.

**Figure 4 Coupling dimensions - Models 0.3 to 6**

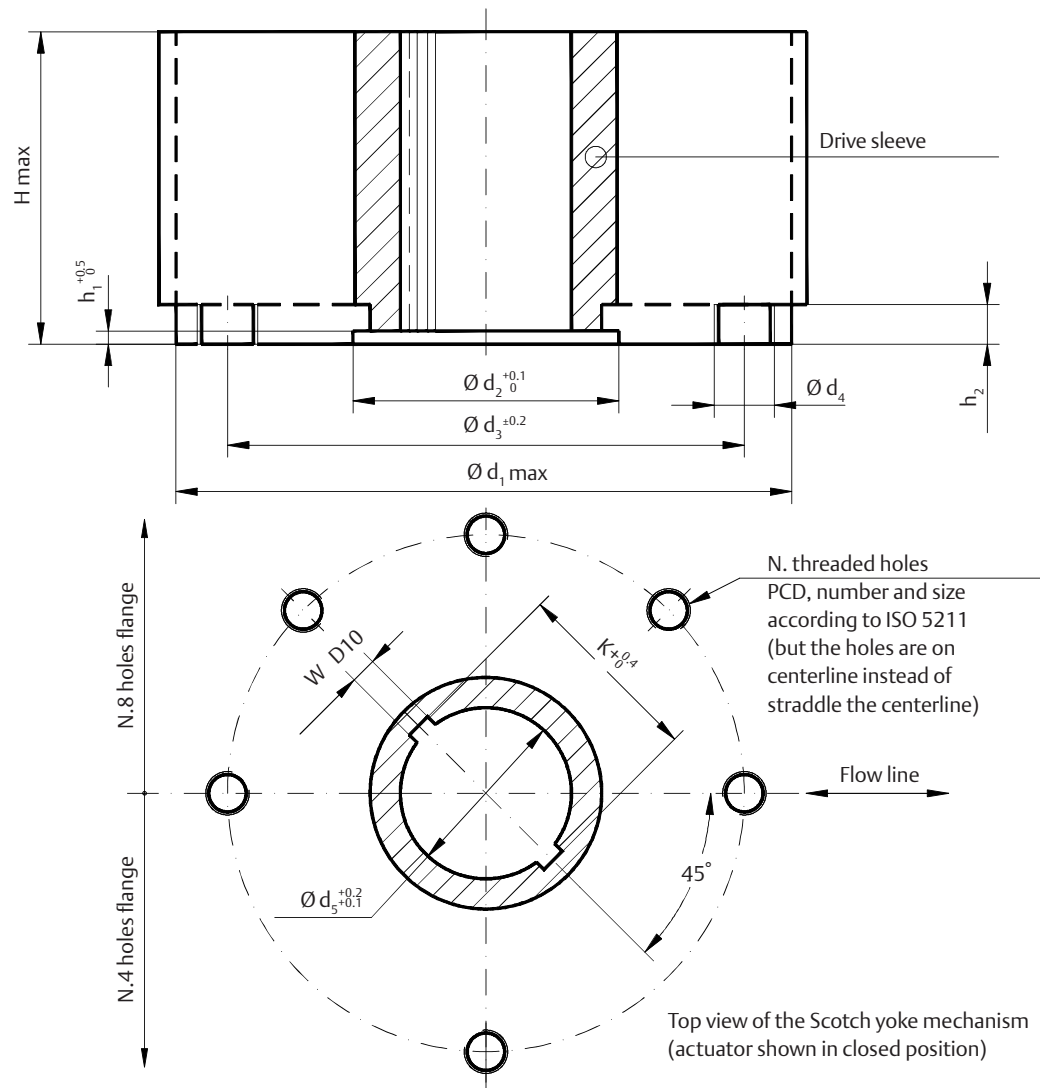

**Table 1. SCN6200**

Dimensions in millimeters

Actuator model	Ø d <sub>1</sub>	Ø d <sub>2</sub>	Ø d <sub>3</sub>	Ø d <sub>4</sub>	N	h <sub>1</sub>	h <sub>2</sub>	H max	Ø d <sub>5</sub>	W	K
0.3	240	93	165	M20	4	5	17	127	70	12	75.6
0.9	310	112	254	M16	8	5	19	150	86	14	93.6
1.5	360	144	298	M20	8	6	19	190	112	18	119.0
3	430	195	356	M30	8	9	23	200	157	25	167.8
6	520	250	406	M36	8	14	29	260	200	28	212.8

Figure 5 Coupling dimensions - Models 14 to 42

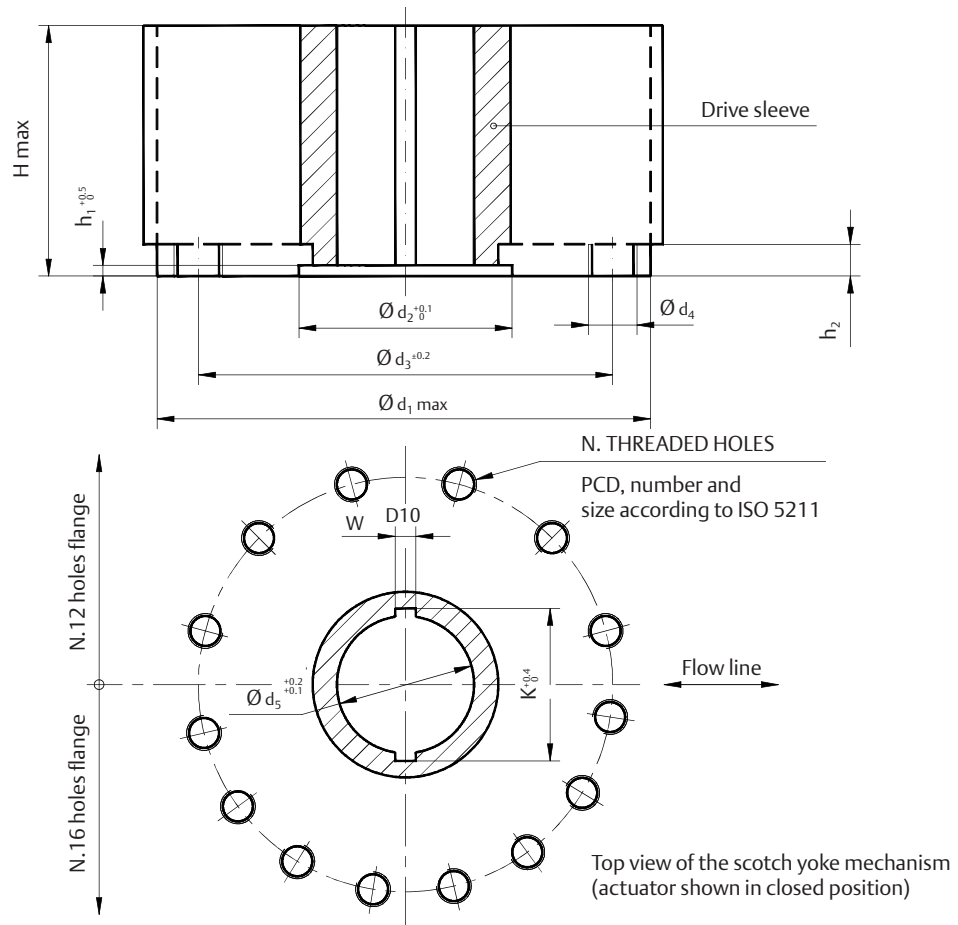
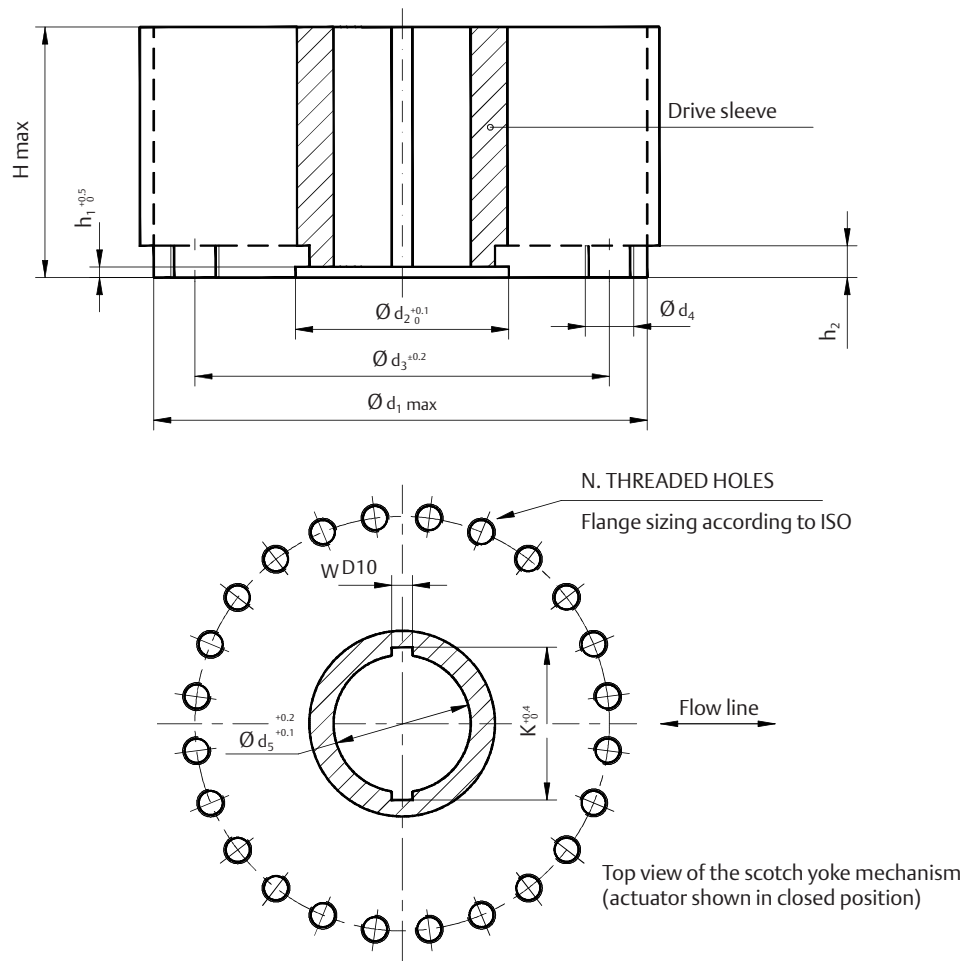

Table 2. SCN6201

Dimensions in millimeters

Actuator model	$\varnothing d_1$	$\varnothing d_2$	$\varnothing d_3$	$\varnothing d_4$	N	$h_1$	$h_2$	H max	$\varnothing d_5$	W	K
14	580	250	483	M36	12	10	29	340	175	45	195.8
18	680	290	603	M36	16	12	32	350	200	45	220.8
32	780	290	603	M36	16	12	32	400	220	50	242.8
35	780	315	603	M36	16	11	32	400	240	50	242.8
42	840	310	603	M36	16	12	32	400	220	50	242.8

**Figure 6 Coupling dimensions - Models 50 and 60**



**Table 3. SCN6201-1**

Dimensions in millimeters

Actuator model	$\varnothing d_1$	$\varnothing d_2$	$\varnothing d_3$	$\varnothing d_4$	N	$h_1$	$h_2$	H max	$\varnothing d_5$	W	K
50	800	315	698	M36	24	10	32	430	240	56	264.8
60	840	315	698	M36	24	10	32	430	240	56	264.8

If required, for the standard models size 0.3 to 6, Biffi can supply an insert bush with unmachined bore in accordance with Biffi standard table SCN6202 enclosed. On request, the insert bush bore can be machined by Biffi to couple the valve stem, provided its dimensions match the maximum stem acceptance of the bush according to Biffi table TN1005, enclosed. The particular execution of the flange and bushing allow the actuator to be rotated by 90° in 4 different positions according to Figure 7.

**Figure 7** Insert bush + intermediate coupling flange

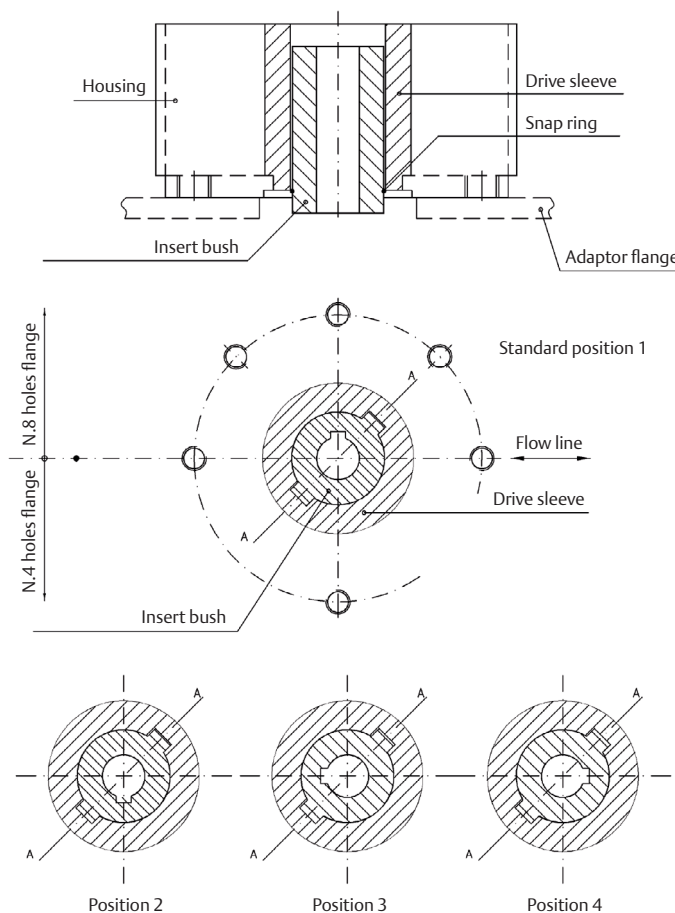

**Table 4.**

Position 2	Position 3	Position 4
Rotate insert-bush 180° around vertical-standard position (1)	Rotate insert-bush 180° around axis A-A, from position (2)	Rotate insert-bush 180° around axis A-A, from position (1)
<b>Insert bush turned upside down</b>		

The Biffi insert bush with 2 external keys at 45° allows to position the keyway for the valve every 90°. Consequently, actuator can be mounted in 4 positions at 90° on top of the valve. For biggest actuator models, the bore of the yoke can be machined according to the dimensions of valve stem.

## 2.4.2 Assembly Procedure

### NOTICE

Failure to comply with the following procedures may impair product warranty.

### WARNING

Installation, commissioning and maintenance, and repair works should be carried out by qualified staff. A non-conforming assembly could be the source of serious accidents.

For actuator assembly on the valve:

### NOTICE

Check that the assembly position, as shown on the documentation, complies with system's geometry. Check the consistency of the parts of actuator-valve coupling.

- Operate the actuator so that it reaches the matching valve position (Section 3.3).
- Lubricate valve stem with oil or grease.
- Properly clean and remove grease from valve coupling flange surfaces.
- Connect, if supplied separately, the adjustment insert to valve stem and fasten it with the special fastening pins.
- Lift the actuator using the special lifting points (Section 2.2).
- Install the actuator so that valve stem inserts in the coupling area. This coupling should be made without forcing.
- Fasten the two parts with the threaded connections (screws, tie rods, nuts). If holes of coupling flanges are not aligned, adequately operate the actuator if necessary move the mechanical stops backwards (Section 3.4).
- Fasten threaded connections. Please refer to Table 5.

**Table 5. Nuts tightening torque**

Threading	Tightening torque (Nm)
M8	20
M10	40
M12	70
M14	110
M16	160
M20	320
M22	420
M24	550
M27	800
M30	1100
M33	1400
M36	1700

The screwing values in Table 5 were calculated considering the materials ASTM A320 L7 for screws or tie rods and ASTM A194 gr.2H for the nuts.

## 2.5 Pneumatic Connections

### WARNING

Check that the values of pneumatic supply available are compatible with those reported on the identification plate of the actuator.

### NOTICE

The connections should be made by qualified staff. Use pipes, fittings and connections appropriate as for type, material and dimensions.

- Properly deburr the ends of rigid pipes.
- Properly clean the interior of pipes sending through them plenty of the supply fluid used in the system.
- Mould and fasten the connection pipes so that no irregular strains at entries or loosening of threaded connections occur.
- Make the connections according to the operating diagram.
- Check the absence of leakages from pneumatic connections.

## 2.6 Electrical Connections (If Any)

### **⚠ WARNING**

Use components appropriate as for type, material and dimensions. The connections should be made by qualified staff. Before carrying out any operation, cut line power off.

#### **Safety provisions:**

<b>2006/95/EC:</b>	Directive for low voltage equipment (until 19 April 2016) 2014/35/EU from 20 April 2016
<b>2004/108/EC:</b>	Directive for the electromagnetic compatibility (until 19 April 2016) 2014/30/EU from 20 April 2016
<b>94/9/CE:</b>	Directive and safety instructions for use in hazardous Area (until 19 April 2016) 2014/34/EU from 20 April 2016

Remove plastic plugs from cables entries:

- Screw firmly the cable glands.
- Introduce connection cables.
- Make the connections in compliance with applicable wiring diagrams on the documentation supplied.
- Screw the cable gland.
- Replace the plastic plugs of unused entries with metal plugs.

**Figure 8** Junction box on control group (if foreseen)



## 2.7 Commissioning

### WARNING

Check that values of electrical supply to the control group (if foreseen) are compatible with those on the plate on the junction box (Figure 8). Installation, commissioning and maintenance, and repair works should be made by qualified staff.

Upon actuator commissioning, please carry out the following checks:

- Check that paint is not be damaged during transport, if necessary, repair the damages to paint coat.
- Check that the pressure and quality of the gas supply (filtering degree, dehydration) are as prescribed. Check that the feed voltage values of the electric components (solenoid valve coils, microswitches, pressure switches, etc.) are compatible with those reported on the identification plate of the actuator (Figure 1).
- Check that the setting of the components of the actuator control unit (pressure regulator, pressure switches, flow control valves, etc.) meet the plant requirements.
- Carry out all kinds of operations and check their proper execution (Section 3.3).
- Check the absence of leakages in the pneumatic connections. If necessary, tighten the nuts of the pipe-fittings.
- Check proper operation of all the due signalling (valve position, gas supply pressure etc.).
- Make a complete functional test in order to verify all the operations are executed according to operating schematic diagram supplied.

## Section 3: Operation and Use

### 3.1 Operation Description

In the normal operating situation, the direct gas actuator is fed by pressurised gas which flows into the relevant cylinder chamber (for example opening). The cylinder piston stroke causes the actuator operation and the consequent valve movement to the operational position requested (in this case to the “open” position).

Upon a demand, the closing chamber the cylinder is fed by pressurised gas and at the same time the gas is discharged from the open chamber into the return line: the actuator performs the closing operation driven by the piston movement, and the valve moves from the open position to the close (safety-related) position.

Figure 9

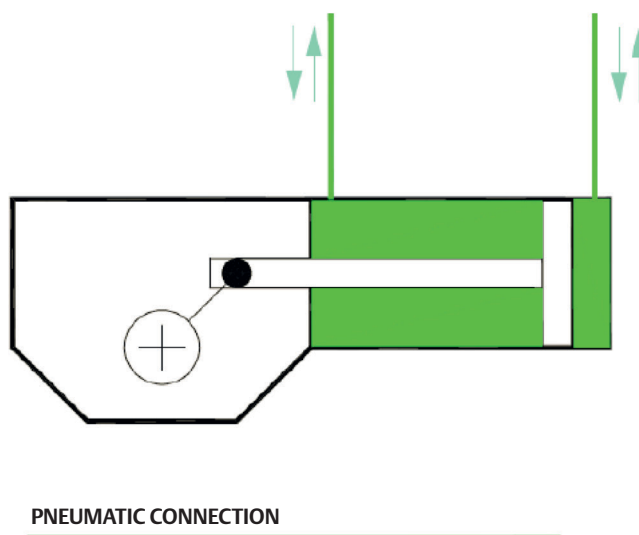

For local or remote operations, please refer to Sections 3.3.1, 3.3.2, 3.3.3 and 3.3.4 and prior to technical documentation furnished with actuators. Typical schematics for various applications are follow attached for information only: in these schematics, actuator operation speed (see Section 3.5) is adjustable by bidirectional flow regulators (item 276) for GIG and GIG with manual jackscrew or handwheel (refer to Figure 10 typical control schematic); for models with manual handpump, speed is adjusted by unidirectional flow regulators (item Fa – Fc) placed on manual override body (refer to Figure 11 and Figure 12).

The power and control systems are supplied on specific customer demand.

#### **⚠ WARNING**

For all the relevant information, please refer to the specific documentation supplied.

Typical Control Schematics

Figure 10 Direct gas actuator local and remote control with "MSJ" (GIG-1)

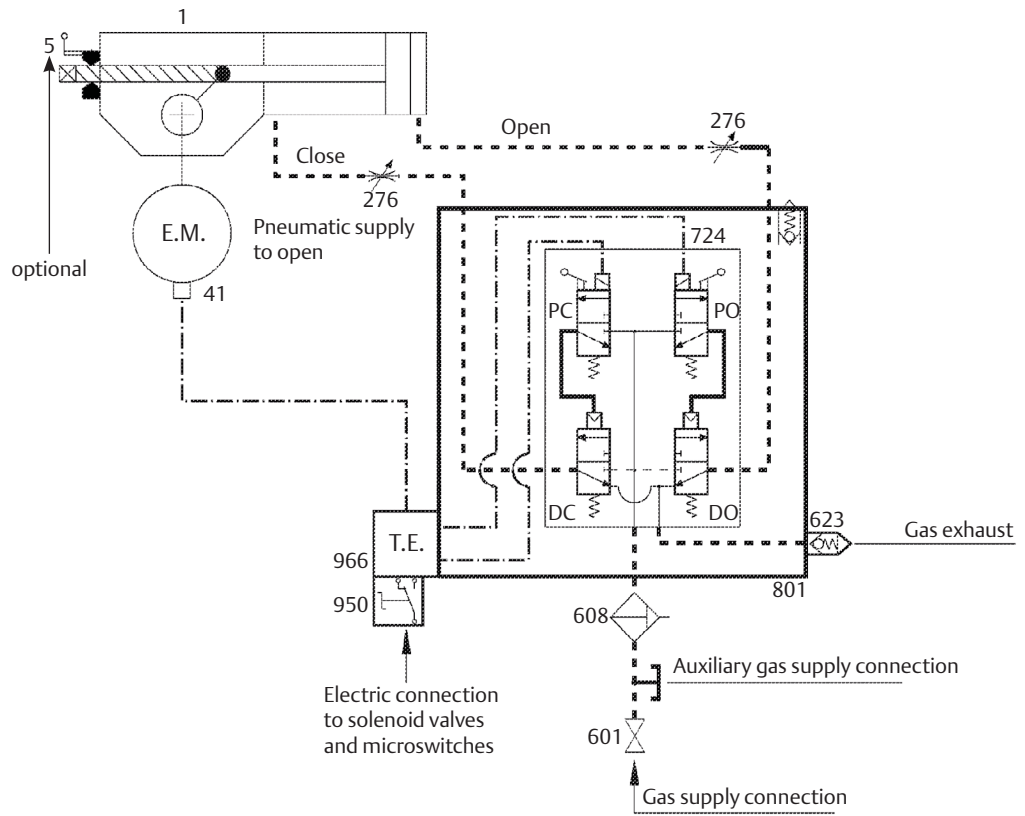

Table 6. Parts list

Item	Description
1	Double-acting pneumatic actuator
5	Manual override
41	Electric microswitches
276	Bidirectional flow regulator (adjustable setting)
601	Stop valve
608	Gas filter/condensate separator
623	Dust excluder with check valve
724	Double 3/2 N.C. solenoid valve with manual override PC = 3/2 N.C. Pil. solenoid valve with manual override (to close) PO = 3/2 N.C. Pil. solenoid valve with manual override (to open) DC = 3/2 N.C. Pneumatic pilot/spring-return valve (to close) DO = 3/2 N.C. Pneumatic pilot/spring-return valve (to open)
801	Control valves enclosure with vent valve
950	Hand operated electric switch
966	Terminal enclosure

Figure 11 Direct gas actuator local and remote control with "MHP" (GIG-2)

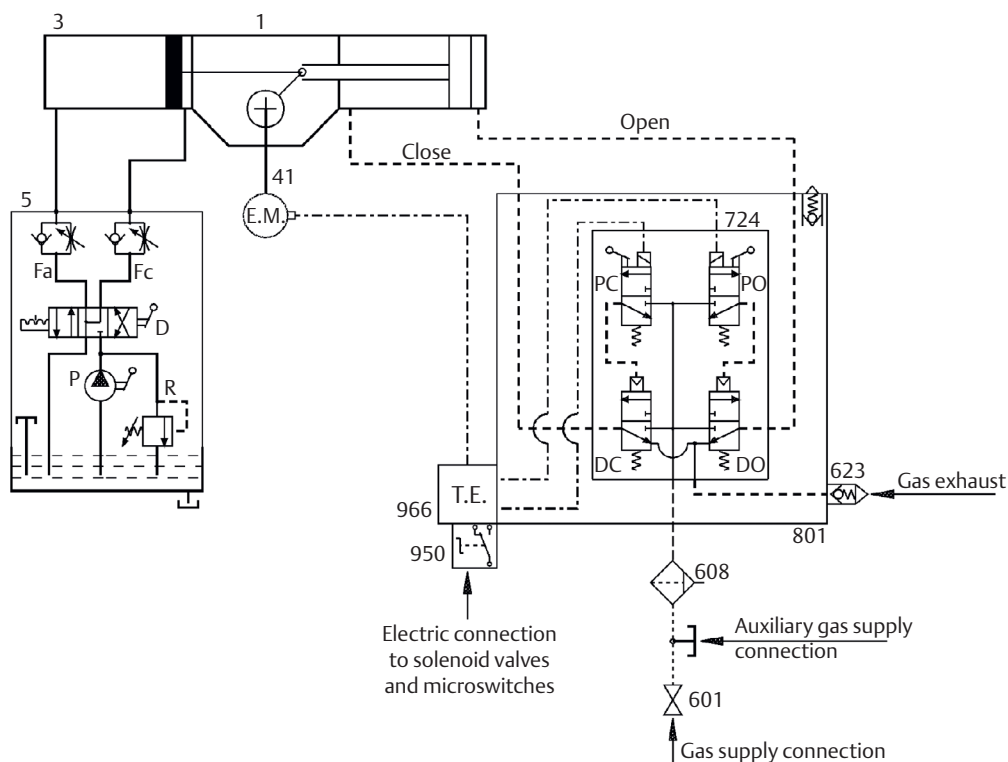

Table 7. Parts list

Item	Description
1	Double-acting pneumatic actuator
3	Hydraulic cylinder
5	Manual override
R	Relief valve
P	Handpump
D	Hand operated directional control valve
Fa	Unidirectional flow regulator (opening operation)
Fc	Unidirectional flow regulator (closing operation)
41	Electric microswitches
601	Stop valve
608	Gas dehydrating filter/condensate separator
623	Dust excluder with check valve
724	Double 3/2 N.C. solenoid valve with manual override PC = 3/2 N.C. Pil. solenoid valve with manual override (to close) PO = 3/2 N.C. Pil. solenoid valve with manual override (to open) DC = 3/2 N.C. Pneumatic pilot/spring-return valve (to close) DO = 3/2 N.C. Pneumatic pilot/spring-return valve (to open)
801	Control valves enclosure with vent valve
950	Hand operated electric switch
966	Terminal enclosure

Figure 12 Direct gas actuator local and remote control - twin gas cylinder (GIG-3)

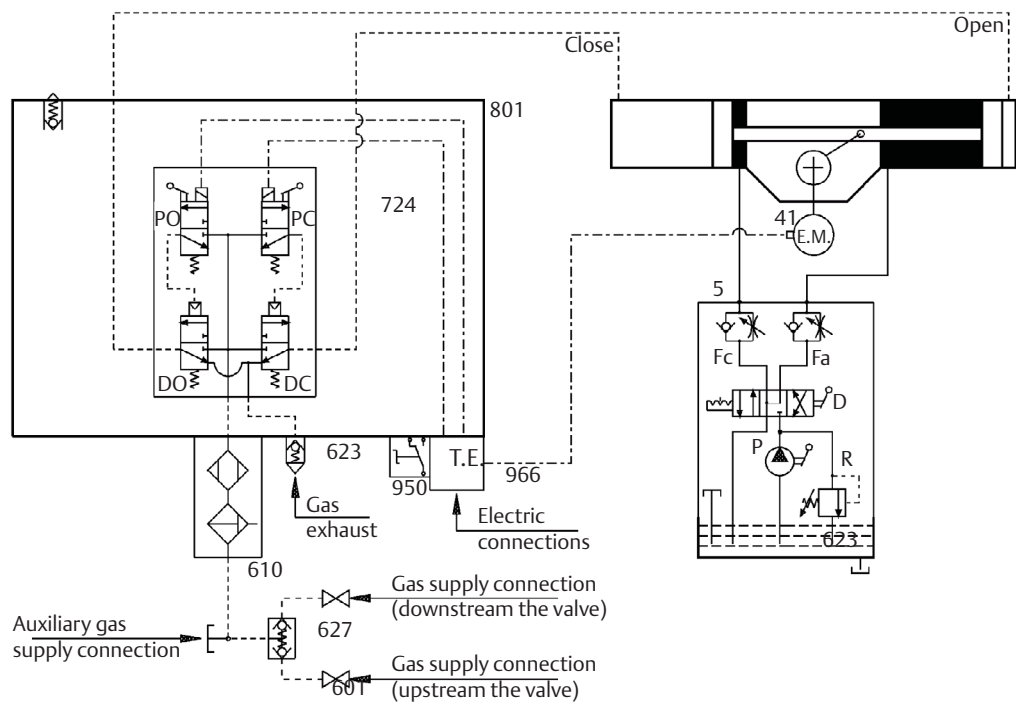

Table 8.

Item	Description
1	Double-acting pneumatic actuator
5	Manual override
R	Relief valve
P	Handpump
D	Hand operated directional control valve
Fa	Unidirectional flow regulator (opening operation)
Fc	Unidirectional flow regulator (closing operation)
41	Electric microswitches
601	Stop valve
610	Gas dehydrating filter/condensate separator
623	Dust excluder with check valve
724	Double 3/2 N.C. solenoid valve with manual override PC = 3/2 N.C. Pil. solenoid valve with manual override (to close) PO = 3/2 N.C. Pil. solenoid valve with manual override (to open) DC = 3/2 N.C. Pneumatic pilot/spring-return valve (to close) DO = 3/2 N.C. Pneumatic pilot/spring-return valve (to open)
801	Control valves enclosure with vent valve
950	Hand operated electric switch
966	Terminal enclosure

## 3.2 Residual Risks

### **⚠ WARNING**

It is recommended to pipe exhaust gas.  
The actuator has parts under pressure.  
Use the due caution.  
Use individual protections provided for by the laws and provisions in force.

## 3.3 Operations

### 3.3.1 Local Pneumatic Operation

### **⚠ WARNING**

Use the proper safety measures to protect from any pressurised gas not piped and from excessive and harmful noise.

**Figure 13** Double solenoid valve with manual control



- Operate the manual control lever of the double solenoid valve in the control group, relevant to the operation to carry out (opening or closing), see Figure 13.
- Check the correct operation of the actuator through the visual position indicator.
- Release the lever to terminate the operation.

### 3.3.2 Electric Remote Control to Open and to Close

- From the control room send the electric signal corresponding to the operation to carry out: energize solenoid valve 724-PO to open or 724-PC to close the actuator, during all the valve stroke.
- Solenoid valves must be de-energized at the end of actuator operation.

### 3.3.3 Emergency Manual Operation by MSJ / MHW

(See Figure 10 – when sufficient line pressure is not available).

**Figure 14**

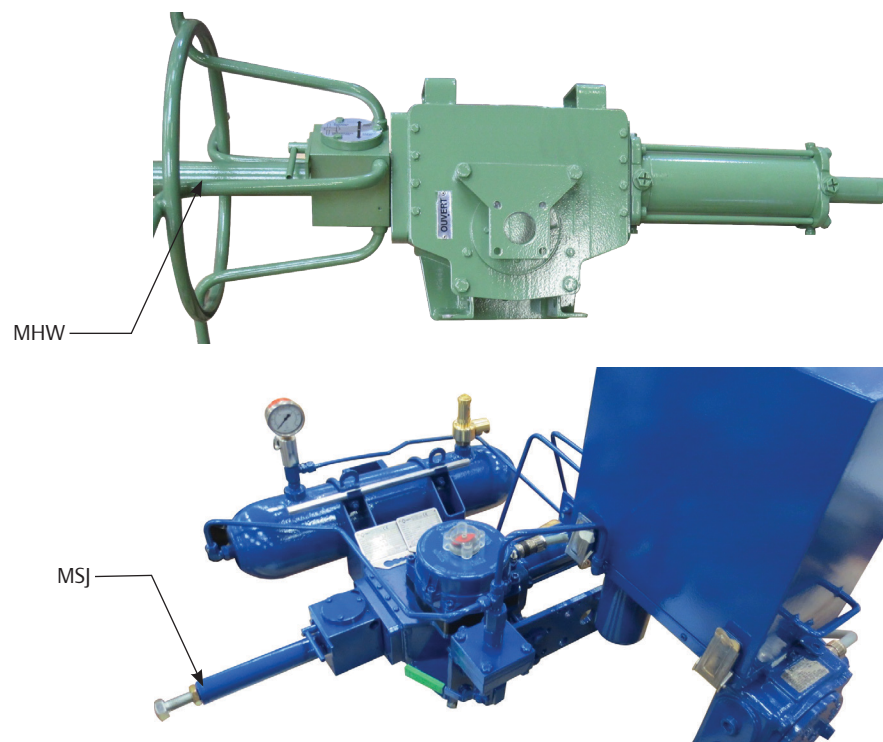

The **MSJ** (jackscrew manual override with removable lever) or the **MHW** (jackscrew manual override with handwheel), can be supplied for GIG actuators up to model 3.

- Engage the manual override by rotating its handle.
- Turn the lever (or the handwheel) the manual override clockwise to close, or counterclockwise to open.
- Check the correct operation of the actuator through the visual position indicator.

Figure 15

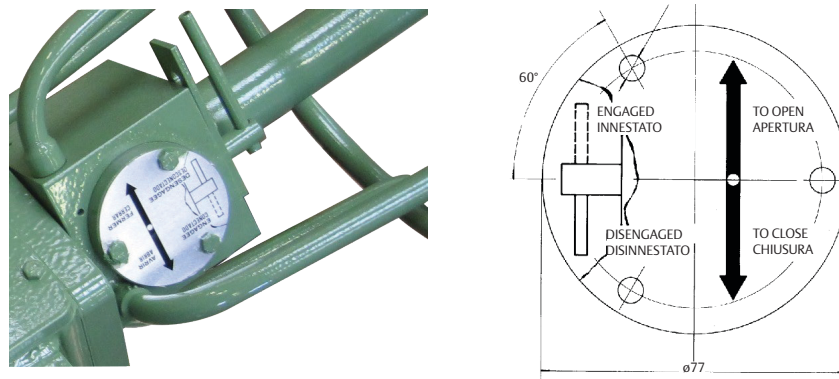

**NOTICE**

To avoid any intentional actuation of manual override, a lockable device can be supplied as option. For safety related applications, a remote signal for MHW/MSJ engaged (by switch) can be supplied as option.

Table 9.

Actuator model	Jackscrew turns per stroke
0.3S - 75MSJ	30
0.3S - 100MSJ	30
0.9S - 100MSJ	35
0.9S - 135MSJ	35
1.5S - 135MSJ	35
1.5S - 175MSJ	35
3S - 135MSJ	56
3S - 175MSJ	56

**⚠ WARNING**

If no other manual operation is carried out, disengaged the manual override to allow the operation with pneumatic supply.

To ensure that the manual override has been correctly disengaged after a manual override operation, the following actions must be done:

- Rotate the handle of MHW or MSJ in “disengaged position”.
- To check the remote functionality, execute operations from remote control, for example partial stroke test (please refer to “Operating Diagram” and to Safety Manual for partial stroke test description) for safety related applications (please see Section 7.2, Figure 46: sectional drawing for Manual Jackscrew MSJ).

### 3.3.4 Emergency Manual Operation by MHP

(See Figure 11 and Figure 12 – when sufficient line pressure is not available).

**Figure 16**

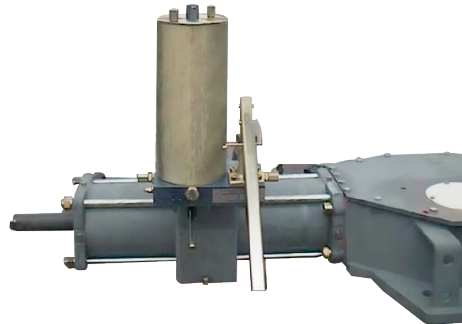

**Figure 17**

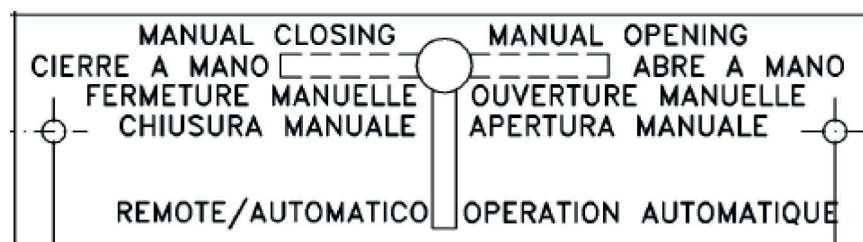

- Select by the lever 5-D the manual opening or manual closing operation.
- Actuated the pump 5-P until to reach the complete operation.
- Check the correct operation of the actuator through the visual position indicator.

**Table 10.**

Actuator model	Handpump operations per stroke	Actuator model	Handpump operations per stroke
0.3*- 75MHP 75	40	14*- 280MHP 200	580
0.3*- 100MHP 75	40	14* - 280MHP 235	800
0.3* - 100MHP 100	70	14*- 280MHP 280	1140
0.9* - 100MHP 100	80	18*- 235MHP 235	900
0.9* - 135MHP 100	80	18* - 280MHP 235	900
0.9* - 135MHP 135	150	18* - 280MHP 280	1300
1.5* - 135MHP 135	180	32* - 235MHP 235	1080
1.5* - 175MHP 135	180	32* - 280MHP 235	1080
1.5* - 175MHP 175	300	32* - 280MHP 280	1500
3* - 135MHP 135	290	50* - 235MHP 235	1200
3* - 175MHP 135	290	50* - 280MHP 235	1200
3* - 175MHP 175	490	50* - 280MHP 280	1700
6* - 175MHP 175	400	50* - 300MHP 235	1200
6* - 200MHP 175	400	50* - 300MHP 280	1700
6* - 200MHP 200	520	50* - 300MHP 300	1930
14* - 200MHP 200	580	80* - 280MHP 280	1983
14* - 235MHP 200	580	80* - 300MHP 300	2251
14* - 235MHP 235	800	80* - 350MHP 350	3063

**⚠ WARNING**

If no other manual operation is carried out, the lever 5-D must be in “remote operation” position to allow the operations with gas supply.

To ensure that the manual override has been correctly disengaged after a manual override operation, the following actions must be done:

- Rotate the lever 5-D of MHP in “remote operation” position.
- To check the remote functionality, execute operations from remote control, for example partial stroke test (please refer to “Operating Diagram” and to Safety Manual for partial stroke test description).

**NOTICE**

To avoid any intentional actuation of manual handpump, a lockable device can be supplied as option. For safety related applications, a remote signal for MHP engaged (by switch) can be supplied as option.

**Figure 18** MHP with lockable engagement lever

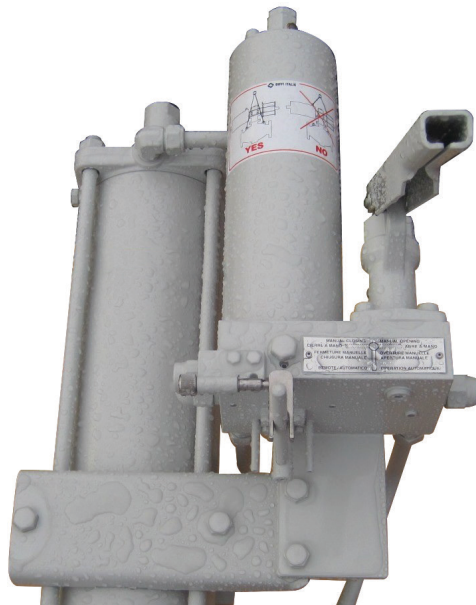

---

**Figure 19** MHP with lockable handpump and signalling switch

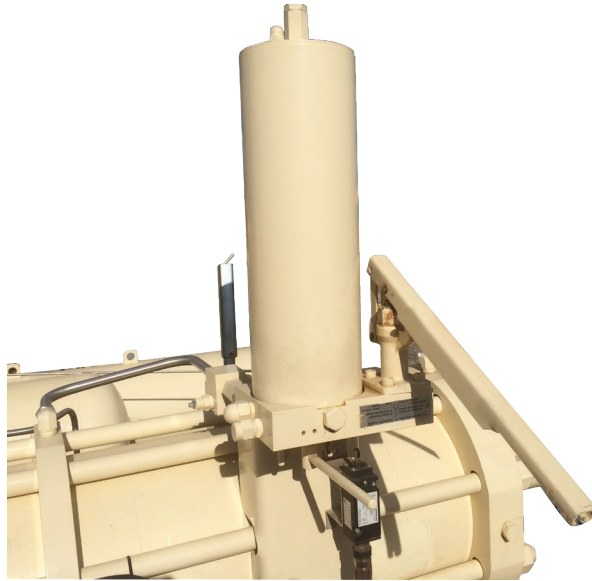

---

(Please see also Section 7.2, Figure 42: sectional drawing for hydraulic control unit MHP).

### NOTICE

Assemble the MHP in vertical position (as shown in Figure 20) to work properly the actuator, any other mounting position is strictly forbidden.

---

**Figure 20**

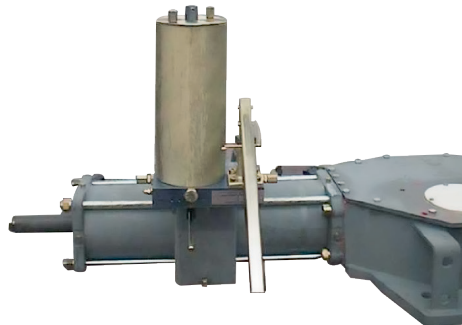

## 3.4 Calibration of the Angular Stroke

The angular stroke of the yoke can be adjusted between  $82^{\circ}$ – $98^{\circ}$  ( $\pm 4^{\circ}$  with respect to the nominal positions of complete opening and closing) by means the mechanical stops screwed into the left side of the housing (open valve) and into the end flange of the hydraulic cylinder (closing) (Figure 21).

**Figure 21** Mechanical stops



In case of an actuator with two cylinders (Figure 22), both mechanical stops are screwed on the end flanges of the cylinders.

**Figure 22** Actuator with two cylinders



For the adjustment of the mechanical stop on the end flange of cylinder, follow these steps (Figure 23):

- Remove with the specific wrench (c1) the plug (t).
- Insert a wrench for Allen keys (c2) in the through hole until reaching the adjustment pin (g).
- Keep the protection cover blocked with the special wrench (c3).
- Turn counterclockwise to increase the angular stroke, turn clockwise to decrease it.
- When the adjustment is over, tighten the plug (t).

**Figure 23** Mechanical stop of the cylinder

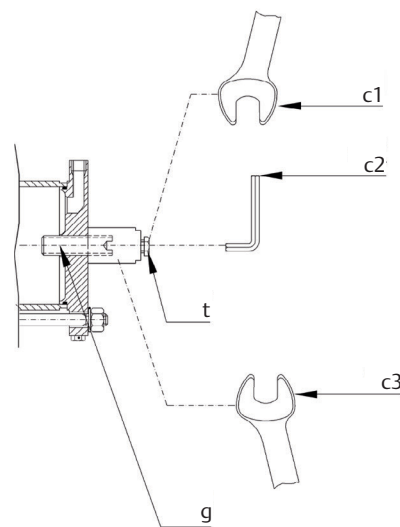

**Table 11.**

Hydraulic Cylinder Size	Wrench C1 (mm)	Wrench C2 (mm)	Wrench C3 (mm)
075	22	10	36
100	22	10	36
135	22	10	36
175	22	14	46
200	27	14	46
235	27	17	65
280	27	17	65
300	36	17	110

For the adjustment of the mechanical stop screwed into the left side of housing, follow these steps (Figure 24 and 25):

- Loosen the locknut (d) with the specific wrench (c2).
- Adjust the pin (g)/screw (v) with the adequate wrench (c1).
- Turn counterclockwise to increase the angular stroke, turn clockwise to decrease it.
- When the adjustment is over, tighten the locknut (d).

**Figure 24 Mechanical stop on the housing**

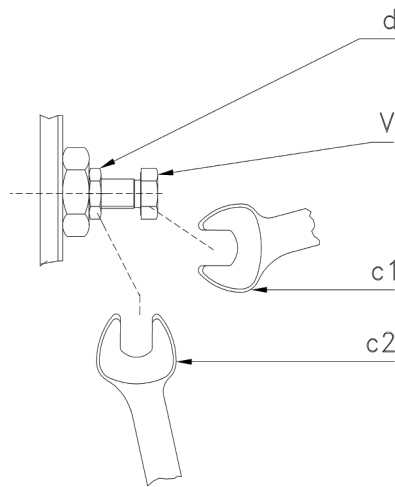

**Table 12.**

GIG actuator model	Wrench C1 (mm)	Wrench C2 (mm)
0.3	30	30
0.9	30	30
1.5	41	41
3	41	41
6	46	46

**Figure 25** Mechanical stop on the housing

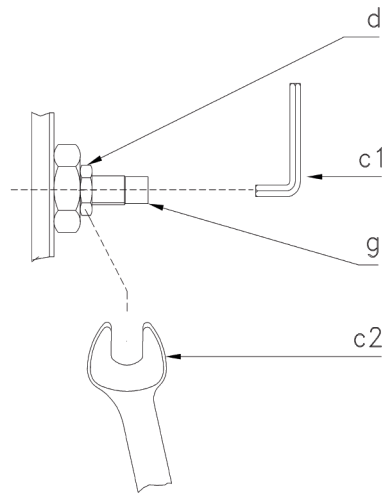

**Table 13.**

GIG actuator model	Wrench c1 (mm)	Wrench c2 (mm)
14	17	60
18	17	60
32	17	60
50	17	60

**Figure 26** (Optional - if foreseen)

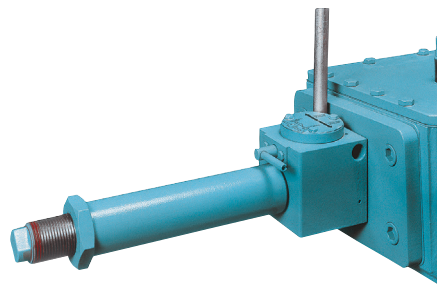

For the adjustment of the mechanical stop screwed on the end flange of manual override (see Section 7.2, Figure 44: sectional drawing for manual jackscrew MSJ or MHW).

**Figure 27 Mechanical stop on the end flange of manual override**

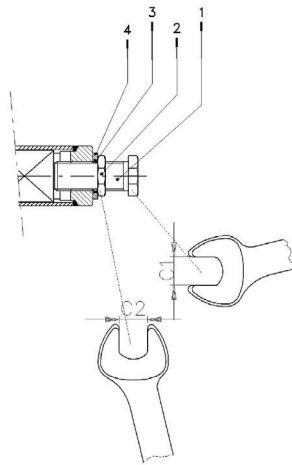

**Table 14.**

GIG actuator size	Wrench C1 (mm)	Wrench C2 (mm)
0.3	34	34
0.9	34	34

**Figure 28 Mechanical stop on the end flange of manual override**

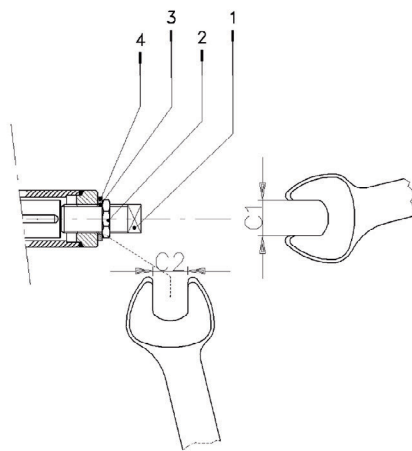

**Table 15.**

GIG actuator size	Wrench C1 (mm)	Wrench C2 (mm)
1.5	24	65
3	24	65

## 3.5 Calibration of Microswitches (Biffi Limit Switch Box Only)

### NOTICE

Operate only the microswitch corresponding to the direction of operation being carried out, as clearly reported on the microswitch.

### ⚠ WARNING

If different microswitches assembly or limit switch box is supplied, please refer to the specific documentation.

Microswitches are placed inside a special box (Figure 29).

For microswitches calibration, please refer to the relative wiring diagram and follow these steps:

- Unscrew the fastening screws of the cover (Figure 29).
- Remove the cover paying attention not to deteriorate the gasket and the cylindrical and flat coupling surfaces.
- Operate the actuator (in opening or closing) with local pneumatic or hydraulic operation (Section 3.3).
- Unscrew the screw of the operating cam relative to the microswitch to calibrate and adjust it according to the settings (Figure 30).
- Tighten the screw.
- Operate the actuator and adjust any other microswitch with the procedure already described.
- Position the cover making sure the cam-carrier shaft grips with the index dragging shaft.
- Check that the cover and the index show the proper position of the valve (Figure 31).
- Tighten the screws.

Figure 29 Microswitches box



Figure 30 Cam adjustment

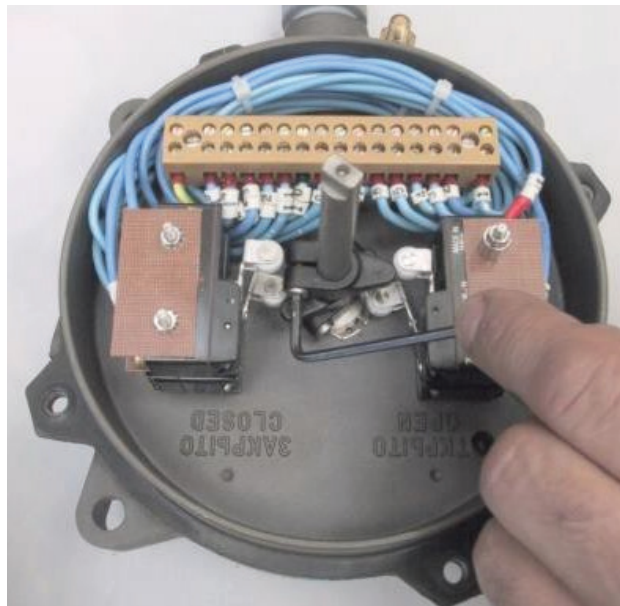

If the index (Figure 31), does not signal the proper position of the valve but is turned by 90°:

- Remove the roll pin placed on the position indicator (index).
- Turn the indicator until reaching its proper positioning.
- Put the roll pin back in its position.

## NOTICE

End of stroke microswitches should be operated before the stop of the stroke of the actuator due to mechanical stops. Adjust the relative cams properly.

**Figure 31** Position indicator and pin for microswitches box

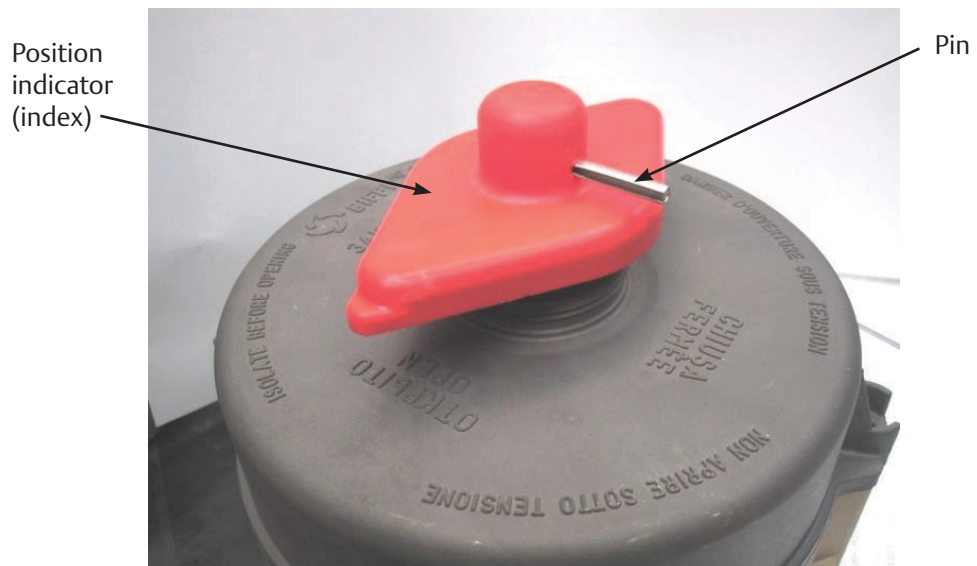

## 3.6 Calibration of the Operation Time

The calibration of the operation time is made by Biffi Italia s.r.l, according to customer requirements and to technical data sheet included in technical documentation. If necessary, it's possible to modify or reset the operating time through two flow regulation valves placed between the control valves enclosure and the pneumatic cylinder (Figure 32).

**Figure 32** Adjustment of operation time

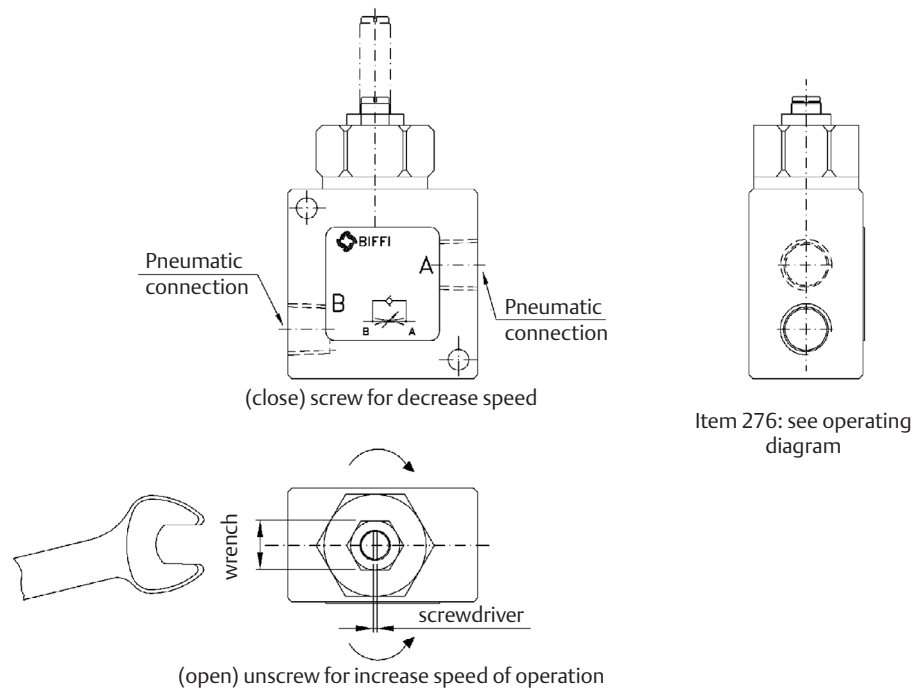

To carry out the adjustment, use an adequate Allen wrench and follow these steps (Figure 32):

- Loosen the locknut.
- Screw with a screwdriver the setting screw to increase the operation time.
- Unscrew with a screwdriver the setting screw to decrease the operation time.
- After the adjustment is over, screw the locknut.

For GIG actuator models with Manual Handpump, the operating time is adjustable through two regulation valves placed on manual handpump body (see Section 7.2, Figure 42: sectional drawing for hydraulic control unit MHP).

To carry out the adjustment, use an adequate Allen wrench and follow these steps (Figure 33):

- Remove the cap nut.
- Loosen the locknut.
- Screw with a screwdriver the setting screw to increase the operation time.
- Unscrew with a screwdriver the setting screw to decrease the operation time.
- After the adjustment is over, screw the locknut and put back in place the cap nut.

**Figure 33** Flow regulators placed on manual handpump

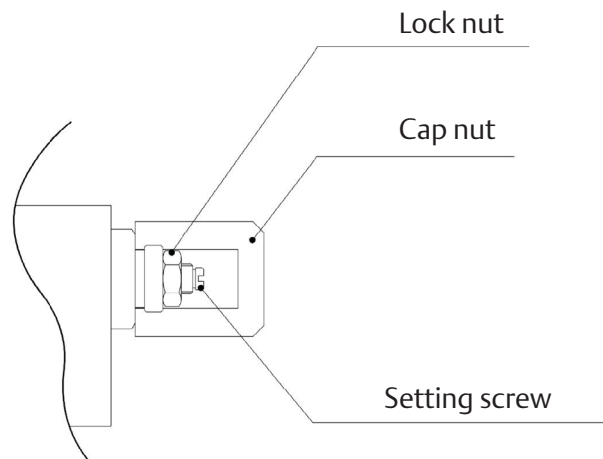

## Section 4: Operational Tests and Inspections

### **NOTICE**

To ensure the guaranteed SIL grade, according to IEC 61508, the functionality of actuator must be checked with regular intervals of time, as described in the Safety Manual.

---

# Section 5: Maintenance

## NOTICE

Before executing any maintenance operation, it is necessary to close the pneumatic supply line and discharge pressure from the cylinder of the actuator and from the control unit (if foreseen).

## ⚠ WARNING

Installation, commissioning and maintenance, and repair works should be carried out by qualified staff. Please refer to warning on Section 1.

## 5.1 Periodic Maintenance

GIG actuators are designed to operate long-term in heavy-duty operating conditions, without maintenance needs.

## NOTICE

Periodicity and regularity of inspections is particularly influenced by specific environmental and working conditions.

## NOTICE

They can be initially determined experimentally and then be improved according to actual maintenance conditions and needs.

Anyway every 2 years of operation, the following is recommended:

- Check that the actuator operates the valve correctly and with the required operating times. If the actuator operation is very infrequent, carry out a few opening and closing operations with all the existing controls (remote control, local control, emergency controls, etc.), if this is allowed by the conditions of the plant.
- Check if there are no hydraulic or pneumatic leakages.
- Check oil level (Figure 34) into the hydraulic control unit (See Section 5.1.1).
- Check if the actuators did not undergo accidental damage with oil leakages found on site (Section 5.1.1).
- Check that improper closing of control-group cover did not produce the presence of condensation on it.
- Check the integrity of worn out parts (gaskets, pads etc.).
- Replace, if any, the mechanical filter of the supply gas (refer to Section 5.1.1).
- If there is an oil filter on the actuator, bleed the condense water accumulated in the cup by opening the drain cock. Disassemble the cup periodically and wash it with soap and water; disassemble the filter: if this is made up of a sintered cartridge, wash it with nitrate solvent and blow through with oil. If the filter is made of cellulose, it must be replaced when clogged.

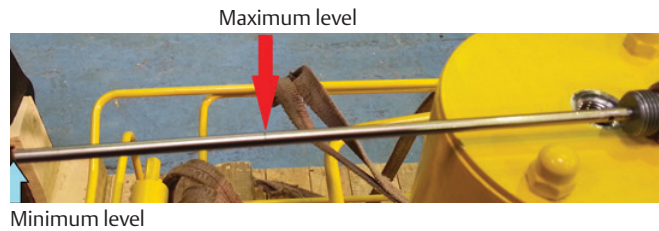
**Figure 34** Level measuring stick

## 5.1.1 Check and Restore Oil Level in the Hydraulic Manual Override

Operate the distributor lever to “closing manual operation”.

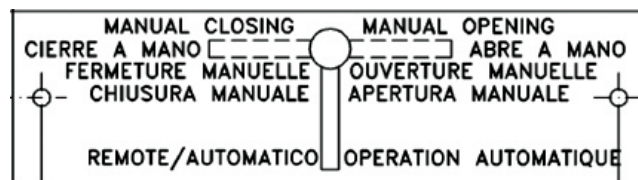
**Figure 35**

Move the actuator into its “fail to close” position.

Unscrew the dipstick (1).

Check that the oil level into the tank (4) is in correspondence of the “MAX LEVEL” notch of the dipstick.

Screw and tighten the dipstick.

If necessary, substitute or add the oil, proceed as follows:

- Remove the dipstick (1) from the tank cover (22).
- Unscrew the plug (27) and the washer (9) to drain all the oil.
- If some dirt or/and sludge is found in the oil drained from the tank, before filling with new oil in the tank, disassemble the oil tank tube, by unscrewing the two cap nuts (2), and clean the internal surfaces of the tank. If necessary, substitute the gaskets (21) of the tank.
- Replace the plug (27) and the washer (9) into the plate (11) and tighten.
- Pour the new oil into the tank through the dipstick hole (1) on the cover (22).
- Replace the dipstick (1).
- Add oil (refer to Table 16) if in the tank the oil level is BELOW THE MINIMUM (Figure 34: minimum level is in correspondence to the end of dipstick) until to reach the optimal (MAXIMUM) oil level.
- Operate the distributor lever to “Remote” position.

**NOTICE**

For refill use oil of the same brand as previous, refer to related technical documentation.

**Table 16. Features of hydraulic oil used by Biffi Italia s.r.l. for refilling different working condition:**

<b>Standard temperature conditions (-30 °C/+85 °C):</b>	
Producer	AGIP
Name	ARNICA 22
Viscosity at 40 °C	20.9 mm <sup>2</sup> /s
Viscosity at 100 °C	4.73 mm <sup>2</sup> /s
Viscosity index ASTM	153
Flash point	192 °C
Pour point	-42 °C
Specific weight (at 15 °C)	0.857 kg/l
Equivalent oils:	SHELL TELLUS PLUS 22 CHEVRON HYDRAULIC OIL AW ISO 22 MOBIL DTE22 EXXON UNIVIS N22 EQUIVIS ZS22 BP ENERGOL HLP-HM22 CASTROL DYSPIIN AWS22
<b>Low temperature conditions (until -46 °C):</b>	
Manufactured	SHELL
Name	AEROSHELL FLUID 41
Viscosity at -54 °C	2300 cST
Viscosity at -40 °C	491 cST
Viscosity at 40 °C	14.1 cST
Viscosity at 100 °C	5.30 cST
Viscosity index (ISO 2909)	>200
Flash point	105 °C
Pour point	<-60 °C
Specific weight	0.87 kg/dm <sup>3</sup>
<b>(or equivalent)</b>	
<b>Low temperature conditions (until -60 °C):</b>	
Manufactured	SYNTHESIS
Name	SYNTRASS-CS 500
Viscosity at -60 °C	580 cST
Viscosity at -30 °C	39 cST
Viscosity at 20 °C	5.8 cST
Viscosity at 50 °C	2.1 cST
Flash point	152 °C
Pour point	-68 °C
Specific weight (or equivalent)	0.897 kg/dm <sup>3</sup>
<b>(or equivalent)</b>	

**Gas supply dehydrating filter maintenance (if foreseen)**

The gas supply filter is fitted with a mechanical filter and a drain valve to discharge periodically the water generated by the condensation of the humidity inside the gas supply.

During the routine maintenance it is recommended to check and clean the mechanical filter and replace it in case of heavy dirty conditions.

To disassemble the filter, proceed as follow:

- A. close the stop valve at the inlet of pressure supply line;
- B. discharge the pressure from the drain valve;
- C. remove the lower enclosure screws,
- D. remove the mechanical filter;
- E. clean or replace the filter;

Reinstall all parts carefully paying attention to avoid any damage to the O-ring.

**Figure 36**

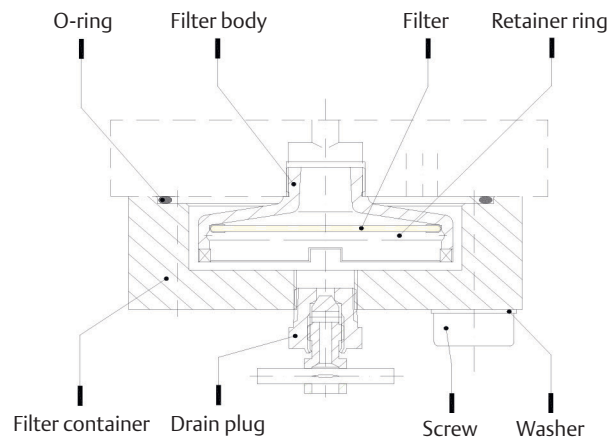

## 5.2 Extraordinary Maintenance

If there are leaks in the hydraulic cylinder, pneumatic cylinder or a malfunction in the mechanical components, or in case of scheduled preventive maintenance, the actuator must be disassembled and seals must be replaced with reference to the follow general sectional drawing and adopting the following procedures.

### 5.2.1 Replacement of Cylinder Seals

#### NOTICE

Before executing any maintenance operation, it is necessary to intercept the supply line and discharge pressure from the cylinder of the actuator.

#### WARNING

If the actuator can be operated, it is essential to take it to fail-safe position, otherwise the actuator should be disassembled from the valve and follow these steps.

1. Unscrew the plug (23) from the cylinder end flange.
2. Measure the distance of the stop screw (20) with reference to the end flange (22) surface, so as to be able to easily restore the setting of the actuator mechanical stop, once the maintenance procedures have been completed.
3. Unscrew the stop screw (20) by turning it anticlockwise with an Allen wrench until the screw is completely with drawn inside the end flange threaded hole.
4. Unscrew the nuts (25) from the tie rods (18): they must be gradually unscrewed all at the same time.
5. Slide off the end flange (22) and the tube (21).
6. If the actuator control unit requires the cylinder chamber head flange side to be also filled with oil, and the piston rod seal ring (40) to be replaced, remove the screw (2) and the cover (1). Unscrew the piston rod (17) threaded end from the adaptor bush (30) of the guide block (14). Slide off the piston rod (17) from the head flange (42).
7. Disassemble the head flange (42) from the mechanism housing (8) by removing the screws (31) only if the gaskets (37) and (39) have to be replaced because damaged.

## Seals Replacement

Prior to reassemble check that the actuator components are in good conditions and clean. Lubricate all the surfaces of the parts, which move in contact with other components, by recommended oil (**SHELL Omala S4 WE 320 or equivalent**). If the O-ring must be replaced, remove the existing one from its groove, clean the groove carefully and lubricate it with protective oil film. Assemble the new O-ring into its groove and lubricate it with a protective oil film. Assemble the new O-ring into its groove and lubricate it with a protective oil film.

1. Replace the O-ring (43) of the head flange (42).
2. Replace the O-ring (43) of the end flange (22).

To replace the piston rod seal rings (40) proceed as follows:

1. Remove the existing Teflon seal ring (40) with its O-ring from their groove.
2. Clean the groove carefully and lubricate it with a protective oil film.
3. Assemble the new O-ring into its groove and lubricate it with a protective oil film.
4. Assemble the new Teflon seal ring (40) into the flange groove, inside its rubber O-ring, by bending it: take care that the bending radius is as large as possible to avoid damaged the seal. Then enlarge the seal ring with your fingers so as to restore its round shape: pay attention not to utilize any tools, which can damage the seal ring.

To replace the piston seal ring (46) proceed as follows:

1. Remove the existing Teflon seal ring (46) with its O-ring from their groove.
2. Clean the groove carefully and lubricate it with a protective oil film.
3. Assemble the new O-ring into its groove and lubricate it with a protective oil film.
4. Assemble the new Teflon seal ring (46) on its rubber O-ring by introducing one side of it into the groove, then enlarge it with your fingers so as to fit it into the groove: take care to enlarge it uniformly without any tools which could possibly damage it. The elastic memory of the kind of Teflon the seal ring is made of allows the ring to shrink back to its previous dimension after a short time.

### Reassemble

1. Assemble the new gasket (37 - 39) after cleaning the surfaces of housing (8), the flange (38) and head flange (42), which are in contact.
2. Assemble the head flange (42), replace the washers if damaged, tighten the screws (31) to the recommended torque.
3. Lubricate the piston rod (17) surface, with a protective oil film and introduce it into the head flange hole, taking care not to damage the O-ring (39). Carefully clean the threaded end of the piston rod (17) and the threaded hole of the adaptor bush (30) of guide block (14). Spread some sealant LOCTITE 452, or equivalent, on the rod threaded end and tighten.
4. Carefully clean the inside of the tube (21) and check that the entire surface, particularly that of the bevels, is not damaged. Lubricate with a protective oil film the tube internal surface and the bevels at the ends. Slide the tube onto the piston taking care not to damage the Teflon seal ring (46): the tube bevel has to smoothly compress the seal ring; take care also not to damage the head flange O-ring (43).
5. Assemble the end flange by centring it on the inside diameter of the tube, taking care not to damage the O-ring (43).
6. Assemble the nuts (25) onto the tie rods (18). Tighten the nuts to the recommended torque, alternating between opposite corners.
7. Restore a generous coating of grease on the contact surfaces of the yoke (11) and the bushings (33), on the yoke grooves, on the sliding blocks (5), on guide bar (9).
8. Assemble the new gasket (10) after cleaning the surfaces of the housing (8) and cover (1).
9. Lubricate with protective oil or grease the O-ring (32).
10. Assemble the cover (1) and the screws (2). Tighten the screws to the recommended torque.
11. Screw the stop screw (20) by turning it clockwise with an Allen wrench until it reaches its original position (the same distance with reference to the end flange surface).
12. Screw the plug (23) into the cylinder end flange.

### NOTICE

Carry out a few operations (Section 3.3) to check there are no leakages from the gaskets.

**Figure 37** GIG-MHP double-acting pneumatic actuator

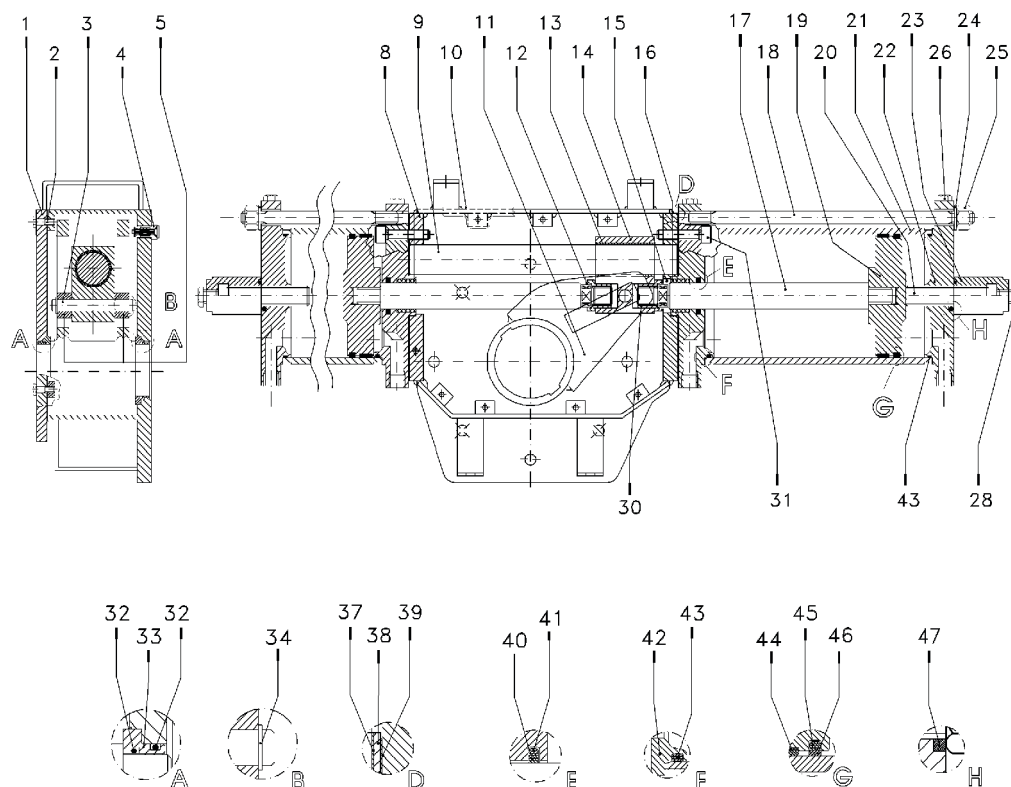

**Table 17.** Parts List

Item	Description	Item	Description
1	Cover	24	Spring washer
2	Screw	25	Nut
3	Guide block pin	26	Plug
4	Vent valve	28	Nut
5	Sliding block	30	Adaptor bush
8	Housing	31	Screw
9	Guide bar	32	O-ring
10	Cover gasket	33	Yoke bushing
11	Yoke	34	Retainer ring
12	Plug	37	Gasket
13	Bushing	38	Flange
14	Guide block	39	Gasket
15	Washer	40	Piston rod seal ring
16	Piston rod bushing	41	O-ring
17	Piston rod	42	Head flange
18	Tie rod	43	O-ring
19	Piston	44	Guide sliding ring for piston
20	Stop setting screw	45	O-ring
21	Cylinder tube	46	Piston seal ring
22	End flange	47	Sealing washer
23	Stop setting screw cover		

## 5.3 Dismantling and Demolition

Before starting the disassembly, a large area should be created around the actuator so to allow any kind of movement without problems of further risks created by worksite.

### **WARNING**

Before disassembling the actuator, it is necessary to close the pneumatic feed line and discharge oil pressure from the cylinder of the actuator, from the control unit and from the accumulator tank, if present.

If actuator is still mounted onto the valve, loosen the threaded connections between valve and actuator (screws, tie rods, nuts).

Lift the actuator using the proper lifting points, see Section 2.2.

If the actuator needs storage, before demolition, see Section 2.3.

### **WARNING**

The demolition of the actuator both concerning any electrical and mechanical parts should be made by specialized staff.

Separate the parts composing the actuator according to their nature (ex. metallic and plastic materials, fluids etc.) and send them to differentiate waste collection sites, as provided for by the laws and provisions in force.

## 5.4 Lubrication of Mechanism

For normal duty, the scotch yoke mechanism of the actuator is lubricated "for life". In case of high load and high frequency of operation it may be necessary to periodically restore lubrication: it is advisable to apply a generous coating of grease on the contact surfaces of the yoke and bushings, on the yoke link grooves, on the sliding blocks, on the guide bar.

For this operation, it is necessary to disassemble the mechanism cover. In larger actuators, the lubrication can be performed through the inspection holes of the cover after removing the plugs.

The following grease is used by Biffi for standard working temperature and suggested for relubrication:

**Table 18.**

AGIP MU/EP2		AEROSHELL GREASE 7 or equivalent	
To be used in standard temperature conditions:	(-30 °C/+85 °C)	To be used in low temperature conditions:	(-60 °C/+65 °C)
NLGI consistency:	2	Color:	Buff
Worked penetration:	280 dmm	Physical state:	Semi-solid at ambient temperature
ASTM Dropping Point:	185 °C	Odor:	Slight
Base oil viscosity at 40 °C:	160 mm <sup>2</sup> /s	Density:	966 kg/m <sup>3</sup> at 15 °C
ISO Classification:	L-X-BCHB 2	Flash Point:	>215 °C (COC) (Based on synthetic oil)
DIN 51 825:	KP2K - 20	Dropping point:	260 °C (ASTM D-566)
Equivalent to:	ESSO BEACON EP2 BP GREASE LTX2 SHELL ALVANIA GREASE R2 ARAL ARALUB HL2 CHEVRON DURALITH GREASE EP2 CHEVRON SPHEEROL AP2 TEXACO MULTIFAK EP2 MOBILPLEX 47 PETROMIN GREASE EP2	Product code:	001A0065
		Infosafe No.:	ACISO GB/eng/C

# Section 6: Troubleshooting

## 6.1 Failure or Breakdown Research

Table 19.

Event	Possible cause	Remedy
Actuator does not work	Lack of power supply	Restore it
	Lack of pneumatic supply	Open line interception valve
	Blocked valve	Repair or replace
	Wrong position of the distributor of the manual hydraulic group	Restore correct position
	Failure of the control group	Call Biffi Italia s.r.l. Customer Service
	Unexpected intervention of torque limit-device	Call Biffi Italia s.r.l. Customer Service
Actuator too slow	Low supply pressure	Restore (Section 1.4)
	Low supply pressure	Restore (Section 1.4)
	Wrong calibration of flow regulator valves	Restore (Section 3.6)
Actuator too fast	Wear of the valve	Replace
	High supply pressure	Restore (Section 1.4)
Leakages on hydraulic or pneumatic circuits	Wrong calibration of flow regulator valves	Restore (Section 3.6)
	Deterioration and/or damage to gaskets	Call Biffi Italia s.r.l. Customer Service
Incorrect position of the valve	Wrong adjustment of mechanical stops	Restore (Section 3.4)
	Wrong warning of microswitches	Restore (Section 3.5)
Hydraulic manual pump does not work	Handle positioned on remote control	Position the handle on the indication of the operation to make
	Leakages on the check valve of the hydraulic control group	Call Biffi Italia s.r.l. Customer Service

# Section 7: Layouts

## 7.1 Spare Parts Order

For spare parts order to the relevant Biffi office, please make reference to Biffi order confirmation concerning all the supply, and serial number of the actuator (Section 1.2) for any specific spare part for a specific actuator model.

**Please send every spare parts request to:**

Biffi Italia s.r.l. - Spare Parts

Tel.: +39 0523-944523

Fax: +39 0523-941885

e-mail: [Biffispares@Emerson.com](mailto:Biffispares@Emerson.com)

**Please specify:**

1. actuator model
2. Biffi acknowledgement
3. spare parts code
4. quantity
5. transport condition
6. involved people

## 7.2 Parts List for Maintenance and Replacing Procedure

Figure 38 Scotch yoke mechanism

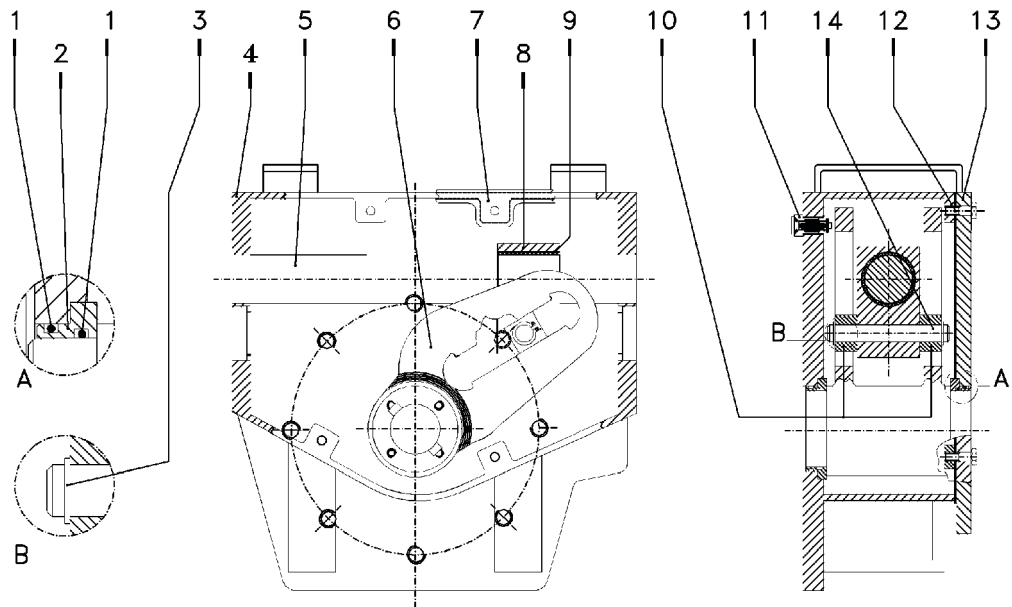

Table 20. Parts List

Item	Qty	Description	Material
1	4	O-ring	* NBR
2	2	Yoke bushing	Bronze
3	2	Retainer ring	Stainless steel
4	1	Housing	Carbon steel
5	1	Guide bar	Alloy steel
6	1	Yoke	Carbon steel
7	1	Cover gasket	* Fiber
8	1	Guide block	Carbon steel
9	1	Bushing	STEEL + BZ + Teflon
10	2	Sliding block	Bronze
11	1	Vent valve	* Stainless steel
12	12	Screw	Carbon steel
13	1	Cover	Carbon steel
14	1	Guide block pin	Alloy steel

**NOTE:**

\* Recommended spare parts

Figure 39 Pneumatic cylinder

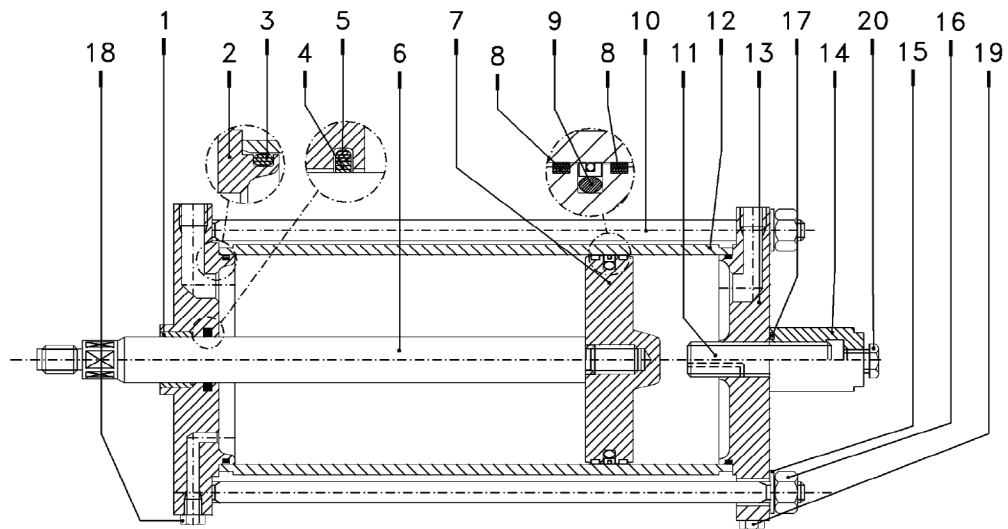

Table 21. Parts List

Item	Qty	Description	Material
1	1	Piston rod bushing	Steel + BZ + Teflon
2	1	Head flange	Carbon steel
3	2	O-ring	* NBR rubber
4	1	Piston rod seal ring	* Teflon + graphite
5	1	O-ring	* NBR rubber
6	1	Piston rod	Alloy steel
7	1	Piston	Nickel plated carbon steel
8	2	Guide sliding ring for piston	* Teflon + graphite
9	1	Piston seal ring	* Teflon + NBR rubber
10	4	Tie rod	Alloy steel - ASTM A320 gr. L7
11	1	Stop-setting screw	Alloy steel
12	1	Cylinder tube	Nickel plated carbon steel
13	1	End flange	Carbon steel
14	1	Stop-setting screw cover	Carbon steel
15	4	Spring washer	Carbon steel
16	4	Nut	Carbon steel - ASTM A194 gr. 7
17	1	O-ring	* NBR rubber
18	6	Plug	Carbon steel
19	1	Plug	Carbon steel
20	1	Plug	Carbon steel

**NOTE:**

\* Recommended spare parts

Figure 40 Hydraulic cylinder

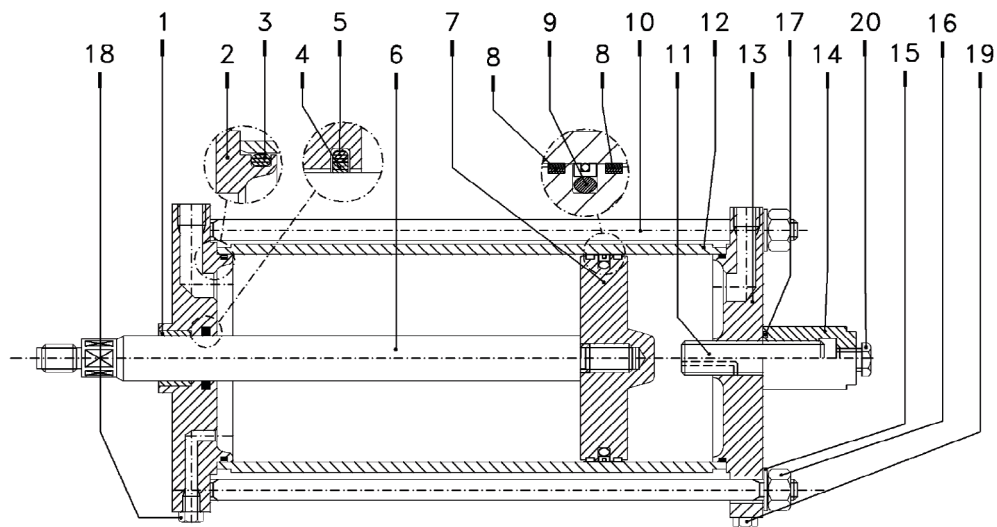

Table 22. Parts List

Item	Qty	Description	Material
1	1	Piston rod bushing	Steel + BZ + Teflon
2	1	Head flange	Carbon steel
3	2	O-ring	* NBR rubber
4	1	Piston rod seal ring	* Teflon + graphite
5	1	O-ring	* NBR rubber
6	1	Piston rod	Alloy steel
7	1	Piston	Nickel plated carbon steel
8	2	Guide sliding ring for piston	* Teflon + graphite
9	1	Piston seal ring	* Teflon + NBR rubber
10	4	Tie rod	Alloy steel - ASTM A320 gr. L7
11	1	Stop-setting screw	Alloy steel
12	1	Cylinder tube	Nickel plated carbon steel
13	1	End flange	Carbon steel
14	1	Stop-setting screw cover	Carbon steel
15	4	Spring washer	Carbon steel
16	4	Nut	Carbon steel - ASTM A194 gr. 7
17	1	O-ring	* NBR rubber
18	6	Plug	Carbon steel
19	1	Plug	Carbon steel
20	1	Plug	Carbon steel

**NOTE:**

\* Recommended spare parts

Figure 41 Assembly kit

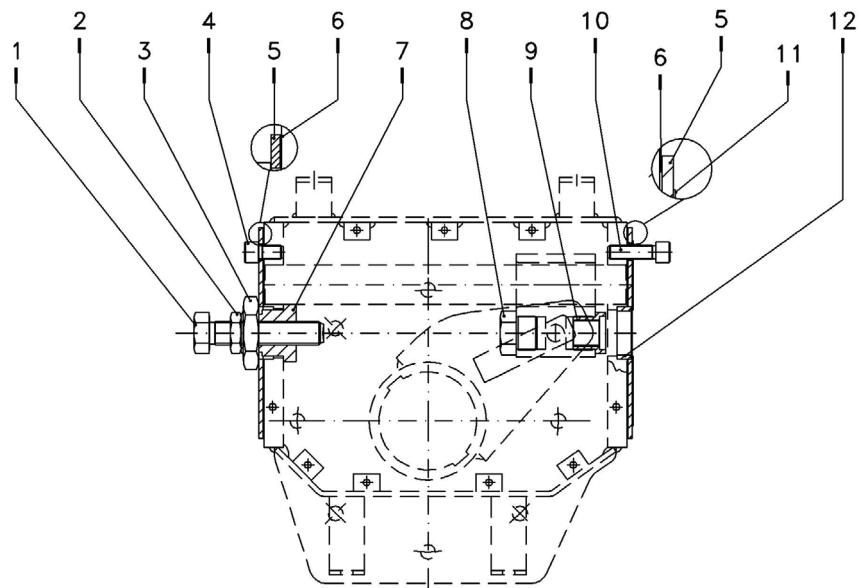

Table 23. Parts List

Item	Qty	Description	Material
1	1	Screw	Alloy steel
2	1	Nut	Carbon steel
3	1	Nut	Carbon steel
4	4	Screw	Alloy steel
5	2	Flange	Carbon steel
6	2	Gasket	* Fiber
7	1	Stopper bush	Alloy steel
8	1	Plug	Alloy steel
9	1	Adaptor bush	Alloy steel
10	4	Screw	Alloy steel
11	1	Gasket	* Fiber
12	1	Washer	Alloy steel

**NOTE:**

\* Recommended spare parts

Figure 42 Hydraulic control unit (Manual Handpump)

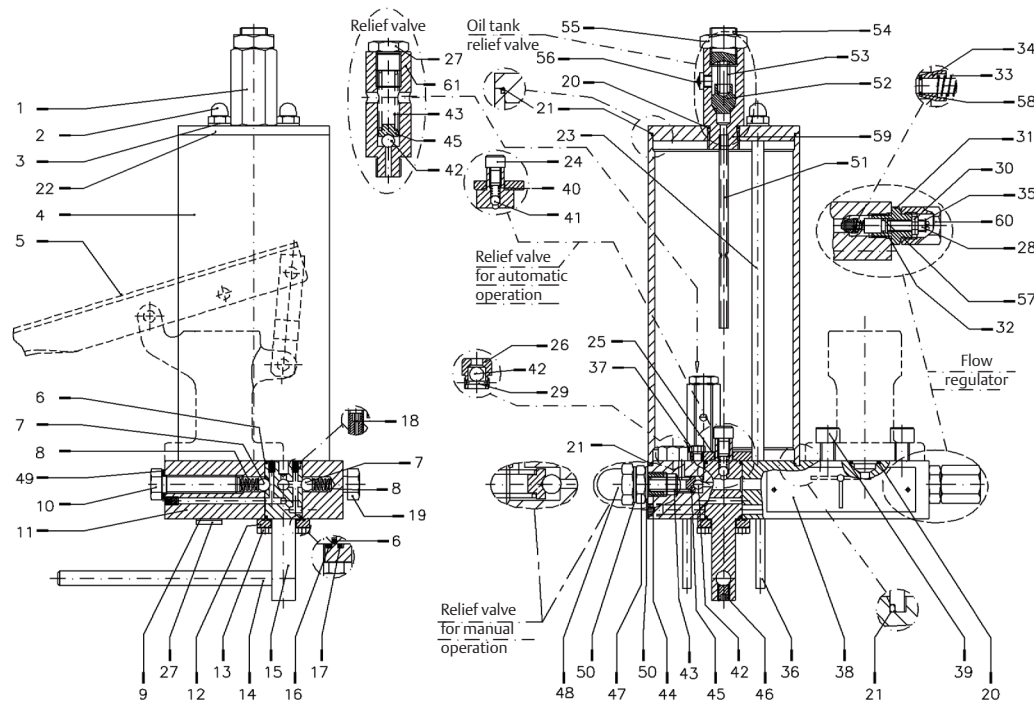

Table 24. Parts List

Item	Qty	Description	Material	Item	Qty	Description	Material
1	1	Dipstick	-	32	2	O-ring	* Fluorosilicon rubber
2	2	Cap nut	Carbon steel	33	2	Spring	Spring steel
3	2	Washer	Carbon steel + rubber	34	2	Plug	Stainless steel
4	1	Hydraulic tank	Carbon steel	35	2	Retainer ring	Spring steel
5	1	Handpump	See attached table	36	2	Spring pin	Carbon steel
6	2	O-ring	* Fluorosilicon rubber	37	4	Screw	Carbon steel
7	2	Ball	Stainless steel	38	1	Operation instruction plate	Stainless steel
8	2	Spring	Spring steel	39	4	Screw	Carbon steel
9	1	Washer	Carbon steel + rubber	40	1	Spring	Stainless steel
10	1	Screw	Carbon steel	41	1	Ball	Stainless steel
11	1	Plate	Carbon steel	42	4	Ball	Stainless steel
12	1	Flange	Aluminium	43	2	Spring	Spring steel
13	4	Screw	Carbon steel	44	1	Relief valve setting screw	Stainless steel
14	1	Lever	Carbon steel	45	2	Spring pin	Carbon steel
15	1	Distributor	Stainless steel	46	1	Screw	Alloy steel
16	1	O-ring	* Fluorosilicon rubber	47	1	Spring	Stainless steel
17	1	O-ring	* Fluorosilicon rubber	48	1	Nut	Carbon steel
18	1	Nozzle	Carbon steel	49	1	Washer	Carbon steel + rubber
19	2	Screw	Carbon steel	50	2	Washer	Carbon steel + rubber
20	3	O-ring	* Fluorosilicon rubber	51	1	Dipstick	Stainless steel
21	2	O-ring	* Fluorosilicon rubber	52	1	Plug + O-ring	* Stainless steel + Fluorosilicon rubber
22	1	Tank cover	Carbon steel	53	1	Spring	Stainless steel
23	2	Tie rod	Carbon steel	54	1	Screw	Alloy steel
24	1	Screw	Carbon steel	55	1	Nut	Carbon steel
25	1	Flange	Aluminium	56	1	Silencer	Brass
26	2	Check valve body	Aluminium	57	2	O-ring	* Fluorosilicon rubber
27	2	Plug	Carbon steel	58	2	Retainer ring	Spring steel
28	2	Flow control valve setting screw	Stainless steel	59	1	Dipstick body	Aluminium
29	2	Spring pin	Stainless steel	60	2	Nut	Carbon steel
30	2	Nut	Carbon steel	61	1	Relief valve body	Aluminium
31	2	Flange	Carbon steel				

NOTE:  
\* Recommended spare parts

Figure 43 Handpump

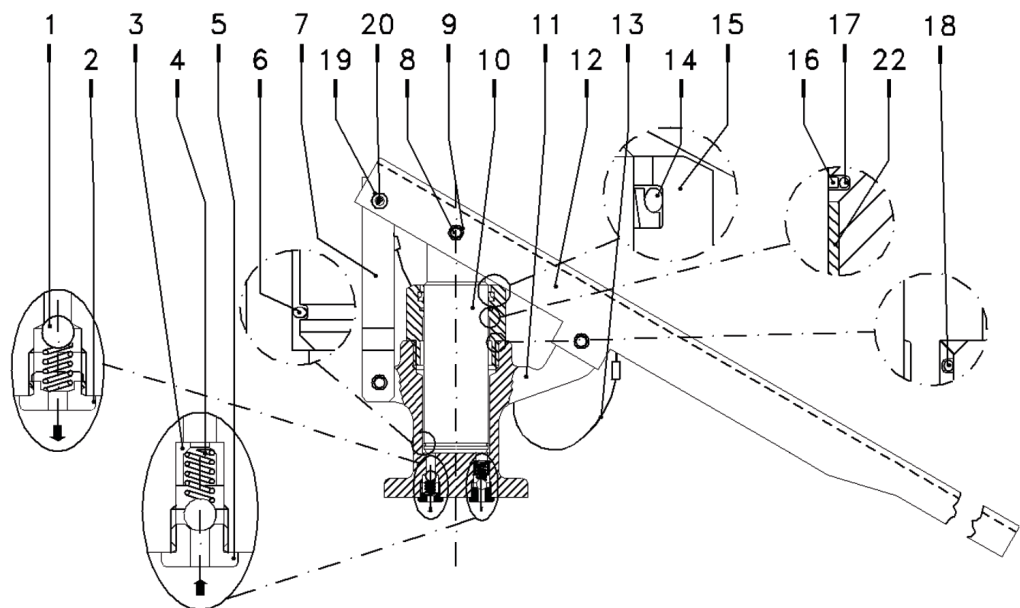
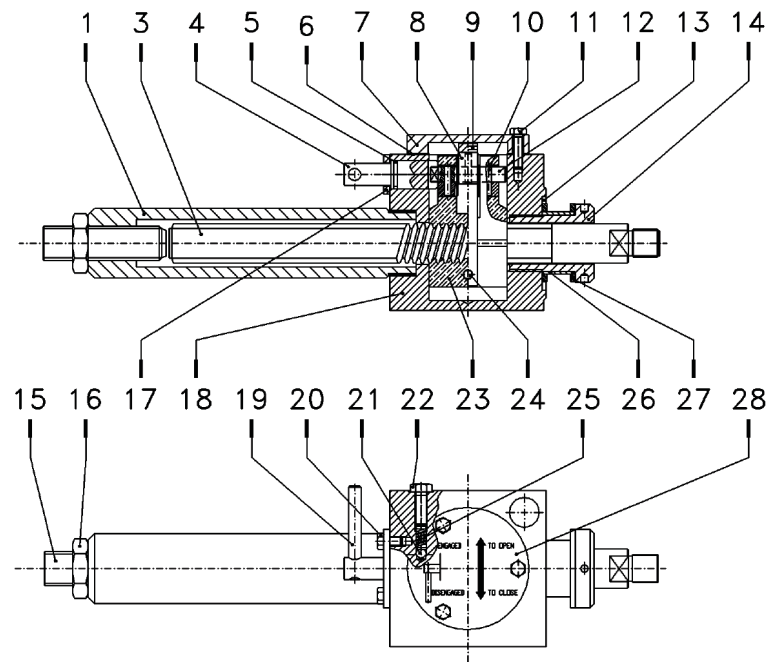

Table 25. Parts List

Item	Qty	Description	Material
1	2	Ball	Stainless steel
2	1	Delivery valve bush	Carbon steel
3	1	Suction valve bush	Carbon steel
4	2	Spring	Stainless steel
5	1	Suction valve seat	Carbon steel
6	1	Spring retainer ring	Carbon steel
7	1	Fork	Carbon steel
8	2	Pin	Stainless steel
9	4	Retainer ring	Carbon steel
10	1	Rod	Alloy steel
11	1	Body	Carbon steel
12	1	Lever	Carbon steel
13	1	Split pin with rope	Nylon + carbon steel
14	1	Scraper ring	* Teflon + fluorosilicon rubber
15	1	Threaded bush	Aluminium
16	2	Rod seal ring	* Teflon + graphite
17	2	O-ring	* Fluorosilicon rubber
18	1	O-ring	* Fluorosilicon rubber
19	1	Nut	Carbon steel
20	1	Screw	Carbon steel
21	1	Fork	Carbon steel
22	1	Piston rod bushing	Steel + BZ + Teflon

**NOTE:**

\* Recommended spare parts

**Figure 44 Mechanical manual override - Jackscrew manual override MSJ or MHW****Table 26. Parts List**

Item	Qty	Description	Material
1	1	Protection pipe	Carbon steel
3	1	Jackscrew	Carbon steel
4	1	Engagement lever pin	Stainless steel
5	1	O-ring	* Fluorosilicon rubber
6	1	Cover gasket	* Fiber
7	1	Cover	Carbon steel
8	3	Cam	Alloy steel
9	1	Fork	Carbon steel
10	3	Spring pin	Stainless steel
11	3	Screw	Carbon steel
12	1	Screw nut operating cam	Alloy steel
13	1	O-ring	* Fluorosilicon rubber
14	1	Thrust block ring nut	Alloy steel
15	1	Screw	Carbon steel
16	1	Nut	Carbon steel
17	1	Flange	Carbon steel
18	1	Body	Carbon steel
19	1	Spring pin	Spring steel
20	2	Screw	Carbon steel
21	1	Ball 1/4"	Stainless steel
22	1	Screw	Carbon steel
23	1	Screw nut	Bronze
24	1	Pin	Carbon steel
25	1	Spring	Spring steel
26	1	Bush	Bronze
27	2	Thrust shoulder washer	Bronze
28	1	Operating instruction plate	Aluminium

**NOTE:**

\* Recommended spare parts

# Section 8: Date Report for Maintenance Operations

Last maintenance operation date:	(in factory, on delivery): ..... exec. by: ..... ..... exec. by: ..... ..... exec. by: .....
Next maintenance operation date:	..... exec. by: ..... ..... exec. by: ..... ..... exec. by: .....
Start-up date:	..... (in factory, on delivery) ..... ..... (on plant) .....

Biffi Italia s.r.l.  
Strada Biffi 165  
29017 Fiorenzuola d'Arda (PC)  
Italy  
T +39 0523 944 411

For complete list of sales and manufacturing sites, please visit  
[www.biffi.it](http://www.biffi.it) or contact us at [biffi\\_italia@biffi.it](mailto:biffi_italia@biffi.it)

VCIOM-16703-EN ©2021 Biffi. All rights reserved.

The contents of this publication are presented for information purposes only, and while every effort has been made to ensure their accuracy, they are not to be construed as warranties or guarantees, express or implied, regarding the products or services described herein or their use or applicability. All sales are governed by our terms and conditions, which are available on request. We reserve the right to modify or improve the designs or specifications of our products at any time without notice.

