

MDE 243



IMVS2000v2 Modbus User Manual



1	16/11/2018	Second Issue	<i>L. Piacenti</i>	<i>A. Battaglia</i>
0	28/10/2016	First Issue	<i>L. Piacenti</i>	<i>A. Battaglia</i>
Rev.	Date	Description	Prepared	Approved

BIFFI ITALIA has taken every care in collecting and verifying the documentation contained in this Installation and User Manual.

The informations herein contained are reserved property of BIFFI ITALIA.

INDEX

1	INTRODUCTION	3
1.1	References	3
2	OPERATION AND STORAGE	4
3	COMMUNICATION FEATURES	4
4	MODBUS WIRINGS	5
4.1	RS485 Transmission Mode	5
5	MODBUS FUNCTION DESCRIPTION	8
5.1	Function Code 03 (0x03) – Read Holding Registers	8
5.2	Function Code 16 (0x10) – Write Multiple Registers	9
5.3	Function Code 20 (0x14) – Read File Record	10
5.3.1	Graph Types	13
5.3.2	Graph Sources	13
5.3.3	Status	13
5.3.4	Pressure Measurement Unit	13
5.3.5	SOVS Used	13
5.3.6	Example to Read Baseline PST Curve (File Number 51):	14
5.4	Exception Codes	22
5.5	Holding Registers Map	23
5.5.1	Pressure 1-2 Registers	52
5.5.2	Process Sensor Registers	52
5.5.3	Pressure Sensor Registers	53
5.5.4	Alarm Status 1	53
5.5.5	Alarm Status 2	54
5.5.6	Alarm Status 3	54
5.5.7	Alarm Log ID	55
6	BUS MENU	56

1 Introduction

The IMVS2000v2 Modbus RTU interface is an electronic module that allows connecting the BIFFI electrical actuator IMVS2000v2 to a MODBUS RTU serial communication line.

It is installed inside the actuator housing, and takes the electrical power from the actuator power supply module.

The RS485 interface is located on the module board. The data lines are fully isolated from the actuator electronic.

1.1 References

[1] *MODBUS over serial line specification and implementation guide V1.0*. Available from www.modbus-IDA.org.

[2] *MODBUS application protocol specification V1.1b*. Available from www.modbus-IDA.org.

[3] *IMVS2000v2 Installation Operating Manual*, MAN720. Available from Biffi Italia.

2 Operation and Storage

The module is designed to work and to be stored in the same environment of the actuator.

3 Communication features

Communication Protocol:	MODBUS RTU
Transmission Tecnology:	RS-485, half-duplex
Network Topology:	Line (bus) structure
Transmission Medium:	Twisted, screened copper cable
Data Rate:	600, 1200, 2400, 4800, 9600, 19200, 38400 bit/sec
Device Number:	Max. 32 devices per segment. If more than 32 devices are present on the bus, repeaters should be used.
Slave Address:	From 1 to 247 (Address 0 reserved for broadcast messages); configurable via local operator interface of actuator
Bus Access:	Polling between master and slave
Electrical Power:	Actuator powered
Bus Termination:	Available on board, configurable via local operator interface of actuator
Temperature:	-40°, +75°C
Auto Baud Rate:	Non Available
EMC protections:	According to generic standard for industrial environments EN61000-6-2 and EN61000-6-4
Baud Rate:	Configurable via local operator interface of actuator
Addressing:	Configurable via local operator interface of actuator
Coding System:	8 bits binary; hexadecimal 0-9, A-F. Two hexadecimal characters contained in each 8 bit field of the message
Bits per Byte:	1 Start bit 8 Data bits (least significant bit sent first) 1 bit for Even/Odd Parity; No bit for No Parity 1 Stop bit with Parity; 2 Stop bits without Parity
Error Check Field:	Cyclical Redundancy Check (CRC)

4 MODBUS Wirings

The maximum number of master and slave devices in a bus segment is 32 without repeaters. The maximum cable length depends on the speed of transmission. Higher is the speed shorter should be the cable length.

The figure below shows a MODBUS RTU configuration with 1 master device and different slave devices

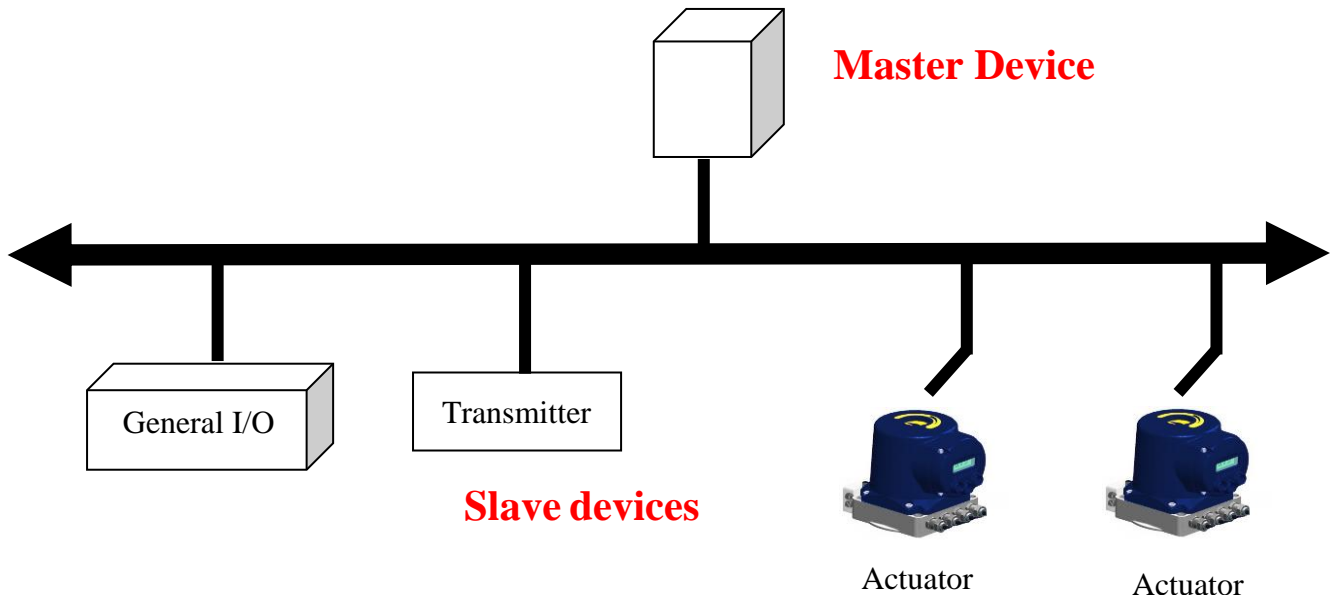

4.1 RS485 Transmission Mode

The IMVS2000v2 Modbus RTU module uses a half-duplex, multidrop, serial communication line RS485. The module communicates with the masters via RS485 interface. Transmission speeds from 600 bit/sec to 38400 bit/sec are available. One unique transmission speed is allowed for all devices on the bus when the system works.

All devices are connected in a bus structure. Up to 32 stations (master and slaves) can be connected in one segment. Repeaters should be used to extend the number of devices on one bus. Addresses range is from 1 to 247. Address 0 is reserved for broadcast messages.

The bus must be terminated by a resistor of 120 Ω at the beginning and at the end of each segment. Only two terminations in one bus segment must be provided. To ensure error-free operation, and to increase driving capability, pull-up and pull-down resistors should be provided on the termination network. The maximum cable length depends on the transmission speed.

The data lines must not be reversed. To avoid polarity inversion, it is suggested to use different colours for each data line. Use of shielded cable is mandatory for having high system immunity against electromagnetic disturbs. The data lines should be kept separate from all other cables. It should be laid in separate, conductive and earthed cable trunking. It must be ensured that there is not voltage difference between individual nodes of bus.

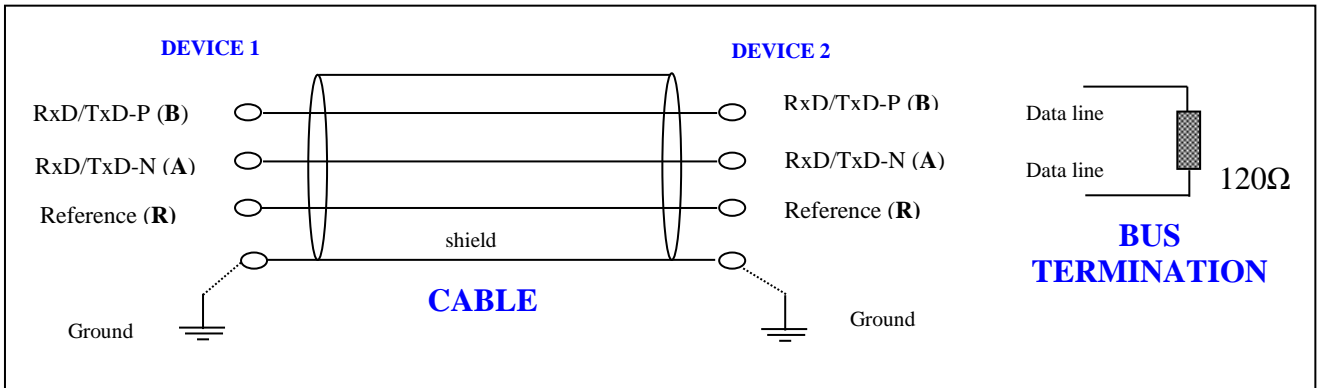

The Modbus RTU interface takes its electrical supply from the IMVS2000v2 power supply. The RS485 bus transceiver is isolated from the actuator electronics. The bus termination, located inside the device, should be used only if the actuator is at the beginning or at the end of the bus segment and if there is no external termination.

The figure below shows the MODBUS wiring.

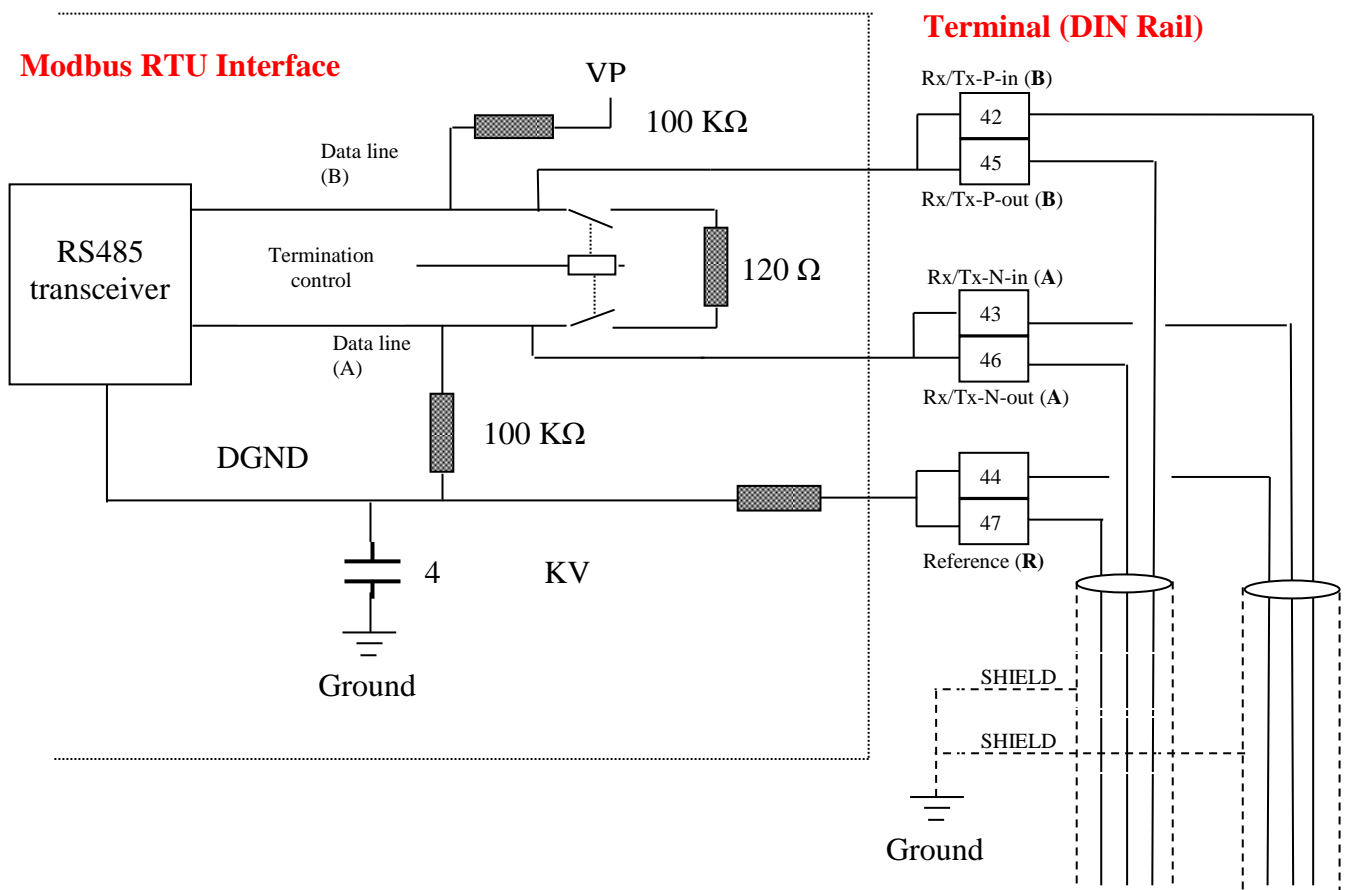

The figure below shows the bus with an actuator at the end of the bus segment.

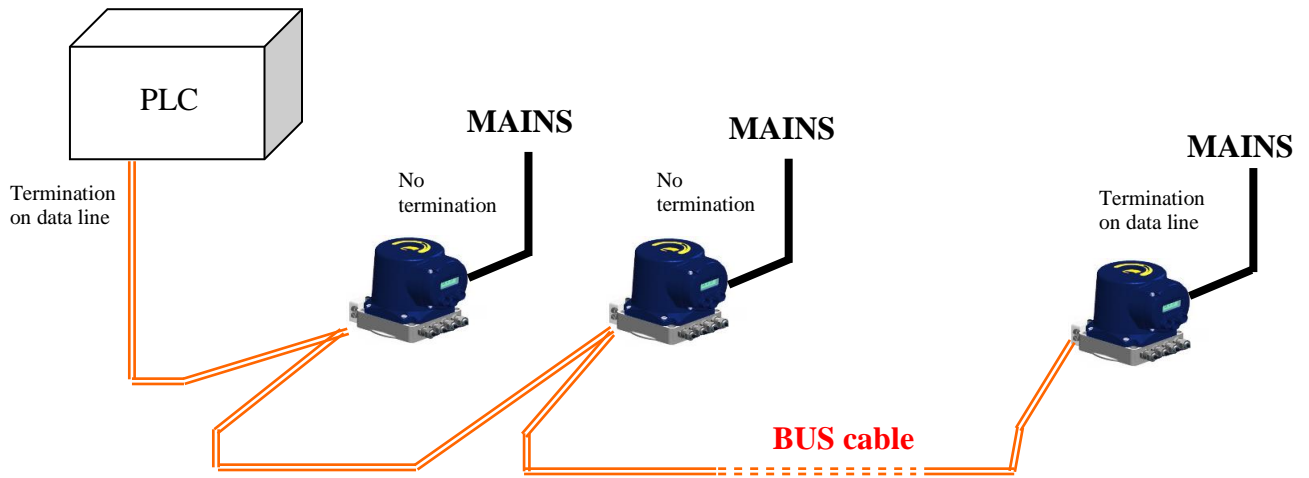

5 MODBUS Function Description

The following paragraph describes the function codes supported by IMVS2000v2 MODBUS RTU Interface.

5.1 Function Code 03 (0x03) – Read Holding Registers

- **References 4x**

This function code is used to read contents of a contiguous block of holding registers (from 1 to 125) in a slave device.

IMVS2000v2 MODBUS RTU Interface has implemented 779 Holding Registers (see Section 5.5 for details).

If the quantity of registers requested is less than 1 or more then 125, Exception Code 03 (0x03) is generated.

If the combination of the starting address and the quantity of registers requested is more than 779, Exception Code 02 (0x02) is generated.

If slave device is engaged to complete a request from the logic card, Exception Code 06 (0x06) is generated.

Broadcast Messages are not allowed.

Example of a request to read Holding Registers 1-2 from Device 13:

Request

Field Name	Value (HEX)
Address	0D
Function Code	03
Start address Hi	00
Start address Lo	00
Quantity of Register Hi	00
Quantity of Register Lo	02
CRC	-

Response

Field Name	Value (HEX)
Address	0D
Function Code	03
Byte Count	04
Holding Register Address 0 Hi	-
Holding Register Address 0 Low	-
Holding Register Address 1 Hi	-
Holding Register Address 1 Low	-
CRC	-

5.2 Function Code 16 (0x10) – Write Multiple Registers

This function code is used to write a block of contiguous registers in a slave device.

The IMVS2000v2 MODBUS RTU Module has implemented 779 Holding Registers (see Section 5.5 for details).

If quantity of registers is less than 1 or more than 125, Exception code 03 (0x03) is generated.

Exception Code 03 (0x03) is also generated if byte count field is not twice of the value of quantity of registers.

If starting address or its combination with quantity of registers is more than 779, Exception Code 02 (0x02) is generated.

If an error occurs while the slave device is performing the action requested in the query, Exception Code 04 (0x04) is generated.

If slave device is engage to complete a request from the logic card, Exception Code 06 (0x06) is generated.

Broadcast messages are allowed, no response is generated after a broadcast request.

Example of a request to write holding registers 1 – 4 (address 0 – 3) to device 2:

Request

Field Name	Value (HEX)
Address	02
Function Code	10
Starting Address Hi	00
Starting Address Lo	00
Quantity of Registers Hi	00
Quantity of Registers Lo	03
Byte Count	06
Register Value Hi (address 0)	00
Register Value Lo (address 0)	04
Register Value Hi (address 1)	01
Register Value Lo (address 1)	F4
Register Value Hi (address 2)	00
Register Value Lo (address 2)	0A
CRC	-

Response

Field Name	Value (HEX)
Address	02
Function Code	10
Starting Address Hi	00
Starting Address Lo	00
Quantity of Registers Hi	00
Quantity of Registers Lo	03
CRC	-

5.3 Function Code 20 (0x14) – Read File Record

This function code is used to perform a file record read. All Request Data Lengths are provided in terms of number of bytes and all Record Lengths are provided in terms of registers.

A file is an organization of records. Each file contains 10000 records, addressed 0000 to 9999 or 0x0000 to 0x270F.

The function can read multiple groups of references. The groups can be separating (non-contiguous), but the references within each group must be sequential.

Each group is defined in a separate “sub-request” field that contains 7 bytes:

- The Reference Type: 1 byte (must be specified as 6)
- The File Number: 2 bytes
- The starting record number within the file: 2 bytes
- The length of the record to be read: 2 bytes

The quantity of registers to be read, combined with all other fields in the expected response, must not exceed the allowable length of the MODBUS PDU: 253 bytes.

The normal response is a series of “sub-responses”, one for each “sub-request”. The byte count field is the total combined count of bytes in all “sub-responses”. In addition, each “sub-response” contains a field that shows its own byte count.

IMVS2000v2 MODBUS RTU Interface uses this function code to read FST, PST and SLOT graphs.

File numbers from 1 to 50 are dedicated for FST graphs.

File numbers from 51 to 100 are dedicated for PST graphs.

File numbers from 101 to 120 are dedicated for SLOT graphs.

If other File numbers are requested, Exception Code 02 (0x02) is generated.

File Numbers 1 and 2 indicate Baseline FST graphs.

File Number 3 is the most recent FST recorded by the device (excluded Baseline).

File Number 50 is the older FST recorded by the device (excluded Baseline).

File Number 51 indicates the Baseline PST graph.

File Number 52 indicates the most recent PST recorded by the device (excluded Baseline).

File Number 100 indicates the older PST recorded by the device (excluded Baseline).

File Numbers from 101 to 120 indicate respectively SLOT1 to SLOT20 (see reference document [3] for details).

The table on the next page describes the structure of a graph (file).

Register	Description	Range Value
0 HIGH	Reserved	
0 LOW	Graph Type	See 5.3.1 for details
1 HIGH	Graph Source	See 5.3.2 for details
1 LOW	Date – Day	1 – 31
2 HIGH	Date – Month	1 – 12
2 LOW	Date – Year (MSB)	2014 – 2099
3 HIGH	Date – Year (LSB)	
3 LOW	Time – Hours	0 – 23
4 HIGH	Time – Minutes	0 – 59
4 LOW	Time – Seconds	0 – 59
5 HIGH	Status	See 5.3.3 for details
5 LOW	Sampling Time (1/4 – MSB)	UINT32 – Not Limited Unit of milliseconds
6 HIGH	Sampling Time (2/4)	
6 LOW	Sampling Time (3/4)	
7 HIGH	Sampling Time (4/4 – LSB)	
7 LOW	Pressure Measurement Unit	See 5.3.4 for details
8 HIGH	Min. Value for P1 – P2 (MSB)	0 – 65535
8 LOW	Min. Value for P1 – P2 (LSB)	See “11 HIGH” for number of decimals
9 HIGH	Max. Value for P1 (MSB)	0 – 65535
9 LOW	Max. Value for P1 (LSB)	See “11 HIGH” for number of decimals
10 HIGH	Max. Value for P2 (MSB)	0 – 65535
10 LOW	Max. Value for P2 (LSB)	See “11 HIGH” for number of decimals
11 HIGH	Decimals for P1, P2 values	0 – 2
11 LOW	Min. Value for Process Pressure (MSB)	0 – 65535
12 HIGH	Min. Value for Process Pressure (LSB)	See “13 LOW” for number of decimals
12 LOW	Max. Value for Process Pressure (MSB)	0 – 65535
13 HIGH	Max. Value for Process Pressure (LSB)	See “13 LOW” for number of decimals
13 LOW	Decimals for Process Pressure values	0 – 2
14 HIGH	Break Pressure (MSB)	-32767 – 32767
14 LOW	Break Pressure (LSB)	See “11 HIGH” for number of decimals
15 HIGH	Break Time (1/4 – MSB)	UINT32 – Not limited hundredths of a second
15 LOW	Break Time (2/4)	
16 HIGH	Break Time (3/4)	
16 LOW	Break Time (4/4 – LSB)	
17 HIGH	Travel Time (1/4 – MSB)	UINT32 – Not limited hundredths of a second
17 LOW	Travel Time (2/4)	
18 HIGH	Travel Time (3/4)	
18 LOW	Travel Time (4/4 – LSB)	
19 HIGH	Graph Samples (MSB)	0 – 351
19 LOW	Graph Samples (LSB)	
20 HIGH	SOVS Used*	See 5.3.5 for details
20 LOW	Absolute Count (1/4 – MSB)	0 – 1000000
21 HIGH	Absolute Count (2/4)	
21 LOW	Absolute Count (3/4)	
22 HIGH	Absolute Count (4/4 – LSB)	

Register	Description	Range Value
22 LOW	PST Set Point (MSB)*	0 – 1000
23 HIGH	PST Set Point (LSB)*	1000 = 100.0%
23 LOW	Reserved	
24 HIGH	Reserved	
24 LOW	Reserved	
25 HIGH	P1 Sample 0 (MSB)	-32767 – 32767
25 LOW	P1 Sample 0 (LSB)	See “11 HIGH” for number of decimals
26 HIGH	P2 Sample 0 (MSB)	-32767 – 32767
26 LOW	P2 Sample 0 (LSB)	See “11 HIGH” for number of decimals
27 HIGH	Process Pressure Sample 0 (MSB)	-32767 – 32767
27 LOW	Process Pressure Sample 0 (LSB)	See “13 LOW” for number of decimals
28 HIGH	Position Sample 0 (MSB)	-32767 – 32767
28 LOW	Position Sample 0 (LSB)	1000 = 100.0 %
29 HIGH	P1-P2 Sample 0 (MSB)	-32767 – 32767
29 LOW	P1-P2 Sample 0 (MSB)	See “11 HIGH” for number of decimals
30 HIGH	P1 Sample 1 (MSB)	-32767 – 32767
30 LOW	P1 Sample 1 (LSB)	See “11 HIGH” for number of decimals
31 HIGH	P2 Sample 1 (MSB)	-32767 – 32767
31 LOW	P2 Sample 1 (LSB)	See “11 HIGH” for number of decimals
32 HIGH	Process Pressure Sample 1 (MSB)	-32767 – 32767
32 LOW	Process Pressure Sample 1 (LSB)	See “13 LOW” for number of decimals
33 HIGH	Position Sample 1 (MSB)	-32767 – 32767
33 LOW	Position Sample 1 (LSB)	1000 = 100.0%
34 HIGH	P1-P2 Sample 1 (MSB)	-32767 – 32767
34 LOW	P1-P2 Sample 1 (LSB)	See “11 HIGH” for number of decimals
...		
...		
...		
1775 HIGH	P1 Sample 350 (MSB)	-32767 – 32767
1775 LOW	P1 Sample 350 (LSB)	See “11 HIGH” for number of decimals
1776 HIGH	P2 Sample 350 (MSB)	-32767 – 32767
1776 LOW	P2 Sample 350 (LSB)	See “11 HIGH” for number of decimals
1777 HIGH	Process Pressure Sample 350 (MSB)	-32767 – 32767
1777 LOW	Process Pressure Sample 350 (LSB)	See “13 LOW” for number of decimals
1778 HIGH	Position Sample 350 (MSB)	-32767 – 32767
1778 LOW	Position Sample 350 (LSB)	1000 = 100.0%
1779 HIGH	P1-P2 Sample 350 (MSB)	-32767 – 32767
1779 LOW	P1-P2 Sample 350 (LSB)	See “11 HIGH” for number of decimals

* This data has sense only for PST Graphs; FST Graphs set it always at 0.

5.3.1 Graph Types

Value	Description
0	FST Close
1	FST Open
2	PST Type
3	Empty

5.3.2 Graph Sources

Value	Description
0	Not Defined
1	Baseline
2	Maintenance
3	Digital Input
4	External Control
5	Baseline PST
6	Manual PST
7	Auto-PST
8	Digital Input PST

5.3.3 Status

Value	Description
0	Not Defined
1	Passed
2	Failed

5.3.4 Pressure Measurement Unit

Value	Description
0	bar
1	psi

5.3.5 SOVS Used

Value	Description
0	SOV A
1	SOV B
2	SOV A, SOV B
3	SOV B, SOV A

5.3.6 Example to Read Baseline PST Curve (File Number 51):

5.3.6.1 Read Curve Data Header (Start Register Address = 0, Number of Registers: 25)

Request

Field Name	Value (HEX)
Address	07
Function Code	14
Byte Count	07
Reference Type	06
File Number Hi	00
File Number Lo	33
Record Number Hi	00
Record Number Lo	00
Record Length Hi	00
Record Length Lo	19
CRC	-

Actuator Configuration

Acting Mode: Single
 Opening Rotation: CCW
 Pressure 1-2 Sensor: 10 bar
 Process Sensor: None
 PST Set Point: 75%

Response

Field Name	Value (HEX)	Field Name	Value (HEX)
Address	07	Record Data Lo (11)	00
Function Code	14	Record Data Hi (12)	00
Resp. Data Length	34	Record Data Lo (12)	00
File Resp. length	33	Record Data Hi (13)	00
Reference Type	06	Record Data Lo (13)	02
Record Data Hi (0)	01	Record Data Hi (14)	00
Record Data Lo (0)	02	Record Data Lo (14)	96
Record Data Hi (1)	05	Record Data Hi (15)	00
Record Data Lo (1)	01	Record Data Lo (15)	00
Record Data Hi (2)	01	Record Data Hi (16)	00
Record Data Lo (2)	07	Record Data Lo (16)	70
Record Data Hi (3)	DE	Record Data Hi (17)	00
Record Data Lo (3)	08	Record Data Lo (17)	00
Record Data Hi (4)	0E	Record Data Hi (18)	00
Record Data Lo (4)	00	Record Data Lo (18)	A7
Record Data Hi (5)	01	Record Data Hi (19)	01
Record Data Lo (5)	00	Record Data Lo (19)	5F
Record Data Hi (6)	00	Record Data Hi (20)	00
Record Data Lo (6)	00	Record Data Lo (20)	00
Record Data Hi (7)	0F	Record Data Hi (21)	00
Record Data Lo (7)	00	Record Data Lo (21)	00
Record Data Hi (8)	00	Record Data Hi (22)	01
Record Data Lo (8)	00	Record Data Lo (22)	02
Record Data Hi (9)	03	Record Data Hi (23)	EE
Record Data Lo (9)	E8	Record Data Lo (23)	00
Record Data Hi (10)	00	Record Data Hi (24)	00
Record Data Lo (10)	00	Record Data Lo (24)	00
Record Data Hi (11)	02	CRC	-

The table on the next page shows the “elaborated” response data bytes received with Function Code 20.

Register Data 0 High = 0x01	⇒	Reserved
Register Data 0 Low = 0x02	⇒	Graph Type: PST
Register Data 1 High = 0x05	⇒	Graph Source: Baseline PST
Register Data 1 Low = 0x01 Register Data 2 High = 0x01 Register Data 2 Low = 0x07 Register Data 3 High = 0xDE	⇒	Date: 01/01/2014
Register Data 3 Low = 0x08 Register Data 4 High = 0x0E Register Data 4 Low = 0x00	⇒	Time: 08:14:00
Register Data 5 High = 0x01	⇒	Status: Passed
Register Data 5 Low = 0x00 Register Data 6 High = 0x00 Register Data 6 Low = 0x00 Register Data 7 High = 0x0F	⇒	Sampling Time: 15ms
Register Data 7 Low = 0x00	⇒	Pressure Measure Unit: bar
Register Data 8 High = 0x00 Register Data 8 Low = 0x00	⇒	P1, P2 Min.: 0 bar
Register Data 9 High = 0x03 Register Data 9 Low = 0xE8	⇒	P1 Max: 1000 ⇒ 10.00 bar
Register Data 10 High = 0x00 Register Data 10 Low = 0x00	⇒	P2 Max: 0 ⇒ 0.00 bar
Register Data 11 High = 0x02	⇒	Decimals for P1, P2 values: 2
Register Data 11 Low = 0x00 Register Data 12 High = 0x00	⇒	Process Pressure Min. values: 0 ⇒ 0.00 bar
Register Data 12 Low = 0x00 Register Data 13 High = 0x00	⇒	Process Pressure Max. values: 0 ⇒ 0.00 bar
Register Data 13 Low = 0x02	⇒	Decimals for Process Pressure values: 2
Register Data 14 High = 0x00 Register Data 14 Low = 0x96	⇒	Break Pressure = 150 ⇒ 1.50 bar
Register Data 15 High = 0x00 Register Data 15 Low = 0x00 Register Data 16 High = 0x00 Register Data 16 Low = 0x70	⇒	Break Time = 112 ⇒ 0.112 sec
Register Data 17 High = 0x00 Register Data 17 Low = 0x00 Register Data 18 High = 0x00 Register Data 18 Low = 0xA7	⇒	Travel Time = 167 ⇒ 0.167 sec
Register Data 19 High = 0x01 Register Data 19 Low = 0x5F	⇒	Graph samples = 351
Register Data 20 High = 0x00	⇒	SOVS Used = 0 ⇒ SOV A
Register Data 20 Low = 0x00 Register Data 21 High = 0x00 Register Data 21 Low = 0x00 Register Data 22 High = 0x01	⇒	Absolute Count (PST) = 1
Register Data 22 Low = 0x02 Register Data 23 High = 0xEE	⇒	PST Set Point = 750 ⇒ 75.0%
Register Data 23 Low = 0x00	⇒	Reserved
Register Data 24 High = 0x00	⇒	Reserved
Register Data 24 Low = 0x00	⇒	Reserved

5.3.6.2 Read Curve Samples 0 - 19

Request

Field Name	Value (HEX)
Address	07
Function Code	14
Byte Count	07
Reference Type	06
File Number Hi	00
File Number Lo	33
Record Number Hi	00
Record Number Lo	19
Record Length Hi	00
Record Length Lo	64
CRC	-

Response

Field Name	Value (HEX)	Field Name	Value (HEX)	Field Name	Value (HEX)	Field Name	Value (HEX)
Address	07	Record Lo (36)	00	Record Lo (50)	C3	Record Lo (64)	00
Function Code	14	Record Hi (37)	00	Record Hi (51)	00	Record Hi (65)	01
Resp. Length	CA	Record Lo (37)	00	Record Lo (51)	00	Record Lo (65)	AD
File Resp. length	C9	Record Hi (38)	03	Record Hi (52)	00	Record Hi (66)	00
Reference Type	06	Record Lo (38)	E8	Record Lo (52)	00	Record Lo (66)	00
Record Hi (25)	01	Record Hi (39)	00	Record Hi (53)	03	Record Hi (67)	00
Record Lo (25)	E3	Record Lo (39)	00	Record Lo (53)	E8	Record Lo (67)	00
Record Hi (26)	00	Record Hi (40)	01	Record Hi (54)	00	Record Hi (68)	03
Record Lo (26)	00	Record Lo (40)	D3	Record Lo (54)	00	Record Lo (68)	E8
Record Hi (27)	00	Record Hi (41)	00	Record Hi (55)	01	Record Hi (69)	00
Record Lo (27)	00	Record Lo (41)	00	Record Lo (55)	BB	Record Lo (69)	00
Record Hi (28)	03	Record Hi (42)	00	Record Hi (56)	00	Record Hi (70)	01
Record Lo (28)	E8	Record Lo (42)	00	Record Lo (56)	00	Record Lo (70)	A5
Record Hi (29)	00	Record Hi (43)	03	Record Hi (57)	00	Record Hi (71)	00
Record Lo (29)	00	Record Lo (43)	E8	Record Lo (57)	00	Record Lo (71)	00
Record Hi (30)	01	Record Hi (44)	00	Record Hi (58)	03	Record Hi (72)	00
Record Lo (30)	E3	Record Lo (44)	00	Record Lo (58)	E8	Record Lo (72)	00
Record Hi (31)	00	Record Hi (45)	01	Record Hi (59)	00	Record Hi (73)	03
Record Lo (31)	00	Record Lo (45)	CC	Record Lo (59)	00	Record Lo (73)	E8
Record Hi (32)	00	Record Hi (46)	00	Record Hi (60)	01	Record Hi (74)	00
Record Lo (32)	00	Record Lo (46)	00	Record Lo (60)	B4	Record Lo (74)	00
Record Hi (33)	03	Record Hi (47)	00	Record Hi (61)	00	Record Hi (75)	01
Record Lo (33)	E8	Record Lo (47)	00	Record Lo (61)	00	Record Lo (75)	9D
Record Hi (34)	00	Record Hi (48)	03	Record Hi (62)	00	Record Hi (76)	00
Record Lo (34)	00	Record Lo (48)	E8	Record Lo (62)	00	Record Lo (76)	00
Record Hi (35)	01	Record Hi (49)	00	Record Hi (63)	03	Record Hi (77)	00
Record Lo (35)	DD	Record Lo (49)	00	Record Lo (63)	E8	Record Lo (77)	00
Record Hi (36)	00	Record Hi (50)	01	Record Hi (64)	00	Record Hi (78)	03

Response continues on the next page.

Field Name	Value (HEX)	Field Name	Value (HEX)	Field Name	Value (HEX)	Field Name	Value (HEX)
Record Lo (78)	E8	Record Lo (92)	00	Record Lo (106)	00	Record Lo (120)	63
Record Hi (79)	00	Record Hi (93)	03	Record Hi (107)	00	Record Hi (121)	00
Record Lo (79)	00	Record Lo (93)	E8	Record Lo (107)	00	Record Lo (121)	00
Record Hi (80)	01	Record Hi (94)	00	Record Hi (108)	03	Record Hi (122)	00
Record Lo (80)	97	Record Lo (94)	00	Record Lo (108)	E8	Record Lo (122)	00
Record Hi (81)	00	Record Hi (95)	01	Record Hi (109)	00	Record Hi (123)	03
Record Lo (81)	00	Record Lo (95)	82	Record Lo (109)	00	Record Lo (123)	E8
Record Hi (82)	00	Record Hi (96)	00	Record Hi (110)	01	Record Hi (124)	00
Record Lo (82)	00	Record Lo (96)	00	Record Lo (110)	6F	Record Lo (124)	00
Record Hi (83)	03	Record Hi (97)	00	Record Hi (111)	00	CRC	-
Record Lo (83)	E8	Record Lo (97)	00	Record Lo (111)	00		
Record Hi (84)	00	Record Hi (98)	03	Record Hi (112)	00		
Record Lo (84)	00	Record Lo (98)	E8	Record Lo (112)	00		
Record Hi (85)	01	Record Hi (99)	00	Record Hi (113)	03		
Record Lo (85)	90	Record Lo (99)	00	Record Lo (113)	E8		
Record Hi (86)	00	Record Hi (100)	01	Record Hi (114)	00		
Record Lo (86)	00	Record Lo (100)	7B	Record Lo (114)	00		
Record Hi (87)	00	Record Hi (101)	00	Record Hi (115)	01		
Record Lo (87)	00	Record Lo (101)	00	Record Lo (115)	69		
Record Hi (88)	03	Record Hi (102)	00	Record Hi (116)	00		
Record Lo (88)	E8	Record Lo (102)	00	Record Lo (116)	00		
Record Hi (89)	00	Record Hi (103)	03	Record Hi (117)	00		
Record Lo (89)	00	Record Lo (103)	E8	Record Lo (117)	00		
Record Hi (90)	01	Record Hi (104)	00	Record Hi (118)	03		
Record Lo (90)	89	Record Lo (104)	00	Record Lo (118)	E8		
Record Hi (91)	00	Record Hi (105)	01	Record Hi (119)	00		
Record Lo (91)	00	Record Lo (105)	75	Record Lo (119)	00		
Record Hi (92)	00	Record Hi (106)	00	Record Hi (120)	01		

The table below shows the “elaborated” response data bytes received with Function Code 20.

Register Data 25 High = 0x01 Register Data 25 Low = 0xE3	⇒ P1Sample 0: 483 ⇒ 4.83 bar
Register Data 26 High = 0x00 Register Data 26 Low = 0x00	⇒ P2 Sample 0: 0 ⇒ 0.00 bar
Register Data 27 High = 0x00 Register Data 27 Low = 0x00	⇒ Process Pressure Sample 0: 0 ⇒ 0.00 bar
Register Data 28 Low = 0x03 Register Data 28 High = 0xE8	⇒ Position Sample 0: 1000 ⇒ 100.0 %
Register Data 29 Low = 0x00 Register Data 29 High = 0x00	⇒ P1-P2 Sample : 0 ⇒ 0.00 bar
Register Data 30 High = 0x01 Register Data 30 Low = 0xE3	⇒ P1Sample 1: 483 ⇒ 4.83 bar
Register Data 31 High = 0x00 Register Data 31 Low = 0x00	⇒ P2 Sample 1: 0 ⇒ 0.00 bar
Register Data 32 High = 0x00 Register Data 32 Low = 0x00	⇒ Process Pressure Sample 1: 0 ⇒ 0.00 bar
Register Data 33 Low = 0x03 Register Data 33 High = 0xE8	⇒ Position Sample 1: 1000 ⇒ 100.0 %
Register Data 34 Low = 0x00 Register Data 34 High = 0x00	⇒ P1-P2 Sample 1: 0 ⇒ 0.00 bar

Register Data 35 High = 0x01 Register Data 35 Low = 0xDD	⇒ P1Sample 2: 477 ⇒ 4.87 bar
Register Data 36 High = 0x00 Register Data 36 Low = 0x00	⇒ P2 Sample 2: 0 ⇒ 0.00 bar
Register Data 37 High = 0x00 Register Data 37 Low = 0x00	⇒ Process Pressure Sample 2: 0 ⇒ 0.00 bar
Register Data 38 Low = 0x03 Register Data 38 High = 0xE8	⇒ Position Sample 2: 1000 ⇒ 100.0 %
Register Data 39 Low = 0x00 Register Data 39 High = 0x00	⇒ P1-P2 Sample 2: 0 ⇒ 0.00 bar
Register Data 40 High = 0x01 Register Data 40 Low = 0xD3	⇒ P1Sample 3: 467 ⇒ 4.67 bar
Register Data 41 High = 0x00 Register Data 41 Low = 0x00	⇒ P2 Sample 3: 0 ⇒ 0.00 bar
Register Data 42 High = 0x00 Register Data 42 Low = 0x00	⇒ Process Pressure Sample 3: 0 ⇒ 0.00 bar
Register Data 43 Low = 0x03 Register Data 43 High = 0xE8	⇒ Position Sample 3: 1000 ⇒ 100.0 %
Register Data 44 Low = 0x00 Register Data 44 High = 0x00	⇒ P1-P2 Sample 3: 0 ⇒ 0.00 bar
Register Data 45 High = 0x01 Register Data 45 Low = 0xCC	⇒ P1Sample 4: 460 ⇒ 4.60 bar
Register Data 46 High = 0x00 Register Data 46 Low = 0x00	⇒ P2 Sample 4: 0 ⇒ 0.00 bar
Register Data 47 High = 0x00 Register Data 47 Low = 0x00	⇒ Process Pressure Sample 4: 0 ⇒ 0.00 bar
Register Data 48 Low = 0x03 Register Data 48 High = 0xE8	⇒ Position Sample 4: 1000 ⇒ 100.0 %
Register Data 49 Low = 0x00 Register Data 49 High = 0x00	⇒ P1-P2 Sample 4: 0 ⇒ 0.00 bar
Register Data 50 High = 0x01 Register Data 50 Low = 0xC3	⇒ P1Sample 5: 451 ⇒ 4.51 bar
Register Data 51 High = 0x00 Register Data 51 Low = 0x00	⇒ P2 Sample 5: 0 ⇒ 0.00 bar
Register Data 52 High = 0x00 Register Data 52 Low = 0x00	⇒ Process Pressure Sample 5: 0 ⇒ 0.00 bar
Register Data 53 Low = 0x03 Register Data 53 High = 0xE8	⇒ Position Sample 5: 1000 ⇒ 100.0 %
Register Data 54 Low = 0x00 Register Data 54 High = 0x00	⇒ P1-P2 Sample 5: 0 ⇒ 0.00 bar
Register Data 55 High = 0x01 Register Data 55 Low = 0xBB	⇒ P1Sample 6: 1000 ⇒ 4.43 bar
Register Data 56 High = 0x00 Register Data 56 Low = 0x00	⇒ P2 Sample 6: 0 ⇒ 0.00 bar
Register Data 57 High = 0x00 Register Data 57 Low = 0x00	⇒ Process Pressure Sample 6: 0 ⇒ 0.00 bar
Register Data 58 Low = 0x03 Register Data 58 High = 0xE8	⇒ Position Sample 6: 1000 ⇒ 100.0 %
Register Data 59 Low = 0x00 Register Data 59 High = 0x00	⇒ P1-P2 Sample 6: 0 ⇒ 0.00 bar
Register Data 60 High = 0x01 Register Data 60 Low = 0xB4	⇒ P1Sample 7: 436 ⇒ 4.36 bar

Register Data 61 High = 0x00 Register Data 61 Low = 0x00	⇒ P2 Sample 7: 0 ⇒ 0.00 bar
Register Data 62 High = 0x00 Register Data 62 Low = 0x00	⇒ Process Pressure Sample 7: 0 ⇒ 0.00 bar
Register Data 63 Low = 0x03 Register Data 63 High = 0xE8	⇒ Position Sample 7: 1000 ⇒ 100.0 %
Register Data 64 Low = 0x00 Register Data 64 High = 0x00	⇒ P1-P2 Sample 7: 0 ⇒ 0.00 bar
Register Data 65 High = 0x01 Register Data 65 Low = 0xAD	⇒ P1Sample 8: 429 ⇒ 4.29 bar
Register Data 66 High = 0x00 Register Data 66 Low = 0x00	⇒ P2 Sample 8: 0 ⇒ 0.00 bar
Register Data 67 High = 0x00 Register Data 67 Low = 0x00	⇒ Process Pressure Sample 8: 0 ⇒ 0.00 bar
Register Data 68 Low = 0x03 Register Data 68 High = 0xE8	⇒ Position Sample 8: 1000 ⇒ 100.0 %
Register Data 69 Low = 0x00 Register Data 69 High = 0x00	⇒ P1-P2 Sample 8: 0 ⇒ 0.00 bar
Register Data 70 High = 0x01 Register Data 70 Low = 0xA5	⇒ P1Sample 9: 421 ⇒ 4.21 bar
Register Data 71 High = 0x00 Register Data 71 Low = 0x00	⇒ P2 Sample 9: 0 ⇒ 0.00 bar
Register Data 72 High = 0x00 Register Data 72 Low = 0x00	⇒ Process Pressure Sample 9: 0 ⇒ 0.00 bar
Register Data 73 Low = 0x03 Register Data 73 High = 0xE8	⇒ Position Sample 9: 1000 ⇒ 100.0 %
Register Data 74 Low = 0x00 Register Data 74 High = 0x00	⇒ P1-P2 Sample 9: 0 ⇒ 0.00 bar
Register Data 75 High = 0x01 Register Data 75 Low = 0x9D	⇒ P1Sample 10: 413 ⇒ 4.13 bar
Register Data 76 High = 0x00 Register Data 76 Low = 0x00	⇒ P2 Sample 10: 0 ⇒ 0.00 bar
Register Data 77 High = 0x00 Register Data 77 Low = 0x00	⇒ Process Pressure Sample 10: 0 ⇒ 0.00 bar
Register Data 78 Low = 0x03 Register Data 78 High = 0xE8	⇒ Position Sample 10: 1000 ⇒ 100.0 %
Register Data 79 Low = 0x00 Register Data 79 High = 0x00	⇒ P1-P2 Sample 10: 0 ⇒ 0.00 bar
Register Data 80 High = 0x01 Register Data 80 Low = 0x97	⇒ P1Sample 11: 407 ⇒ 4.07 bar
Register Data 81 High = 0x00 Register Data 81 Low = 0x00	⇒ P2 Sample 11: 0 ⇒ 0.00 bar
Register Data 82 High = 0x00 Register Data 82 Low = 0x00	⇒ Process Pressure Sample 11: 0 ⇒ 0.00 bar
Register Data 83 Low = 0x03 Register Data 83 High = 0xE8	⇒ Position Sample 11: 1000 ⇒ 100.0 %
Register Data 84 Low = 0x00 Register Data 84 High = 0x00	⇒ P1-P2 Sample 11: 0 ⇒ 0.00 bar
Register Data 85 High = 0x01 Register Data 85 Low = 0x90	⇒ P1Sample 12: 400 ⇒ 4.00 bar
Register Data 86 High = 0x00 Register Data 86 Low = 0x00	⇒ P2 Sample 12: 0 ⇒ 0.00 bar

Register Data 87 High = 0x00 Register Data 87 Low = 0x00	⇒ Process Pressure Sample 12: 0 ⇒ 0.00 bar
Register Data 88 Low = 0x03 Register Data 88 High = 0xE8	⇒ Position Sample 12: 1000 ⇒ 100.0 %
Register Data 89 Low = 0x00 Register Data 89 High = 0x00	⇒ P1-P2 Sample 12: 0 ⇒ 0.00 bar
Register Data 90 High = 0x01 Register Data 90 Low = 0x89	⇒ P1Sample 13: 393 ⇒ 3.93 bar
Register Data 91 High = 0x00 Register Data 91 Low = 0x00	⇒ P2 Sample 13: 0 ⇒ 0.00 bar
Register Data 92 High = 0x00 Register Data 92 Low = 0x00	⇒ Process Pressure Sample 13: 0 ⇒ 0.00 bar
Register Data 93 Low = 0x03 Register Data 93 High = 0xE8	⇒ Position Sample 13: 1000 ⇒ 100.0 %
Register Data 94 Low = 0x00 Register Data 94 High = 0x00	⇒ P1-P2 Sample 13: 0 ⇒ 0.00 bar
Register Data 95 High = 0x01 Register Data 95 Low = 0x82	⇒ P1Sample 14: 386 ⇒ 3.86 bar
Register Data 96 High = 0x00 Register Data 96 Low = 0x00	⇒ P2 Sample 14: 0 ⇒ 0.00 bar
Register Data 97 High = 0x00 Register Data 97 Low = 0x00	⇒ Process Pressure Sample 14: 0 ⇒ 0.00 bar
Register Data 98 Low = 0x03 Register Data 98 High = 0xE8	⇒ Position Sample 14: 1000 ⇒ 100.0 %
Register Data 99 Low = 0x00 Register Data 99 High = 0x00	⇒ P1-P2 Sample 14: 0 ⇒ 0.00 bar
Register Data 100 High = 0x01 Register Data 100 Low = 0x7B	⇒ P1Sample 15: 379 ⇒ 3.79 bar
Register Data 101 High = 0x00 Register Data 101 Low = 0x00	⇒ P2 Sample 15: 0 ⇒ 0.00 bar
Register Data 102 High = 0x00 Register Data 102 Low = 0x00	⇒ Process Pressure Sample 15: 0 ⇒ 0.00 bar
Register Data 103 Low = 0x03 Register Data 103 High = 0xE8	⇒ Position Sample 15: 1000 ⇒ 100.0 %
Register Data 104 Low = 0x00 Register Data 104 High = 0x00	⇒ P1-P2 Sample 15: 0 ⇒ 0.00 bar
Register Data 105 High = 0x01 Register Data 105 Low = 0x75	⇒ P1Sample 16: 373 ⇒ 3.73 bar
Register Data 106 High = 0x00 Register Data 106 Low = 0x00	⇒ P2 Sample 16: 0 ⇒ 0.00 bar
Register Data 107 High = 0x00 Register Data 107 Low = 0x00	⇒ Process Pressure Sample 16: 0 ⇒ 0.00 bar
Register Data 108 Low = 0x03 Register Data 108 High = 0xE8	⇒ Position Sample 16: 1000 ⇒ 100.0 %
Register Data 109 Low = 0x00 Register Data 109 High = 0x00	⇒ P1-P2 Sample 16: 0 ⇒ 0.00 bar
Register Data 110 High = 0x01 Register Data 110 Low = 0x6F	⇒ P1Sample 17: 367 ⇒ 3.67 bar
Register Data 111 High = 0x00 Register Data 111 Low = 0x00	⇒ P2 Sample 17: 0 ⇒ 0.00 bar
Register Data 112 High = 0x00 Register Data 112 Low = 0x00	⇒ Process Pressure Sample 17: 0 ⇒ 0.00 bar

Register Data 113 Low = 0x03 Register Data 113 High = 0xE8	⇒ Position Sample 17: 1000 ⇒ 100.0 %
Register Data 114 Low = 0x00 Register Data 114 High = 0x00	⇒ P1-P2 Sample 17: 0 ⇒ 0.00 bar
Register Data 115 High = 0x01 Register Data 115 Low = 0x69	⇒ P1 Sample 18: 361 ⇒ 3.61 bar
Register Data 116 High = 0x00 Register Data 116 Low = 0x00	⇒ P2 Sample 18: 0 ⇒ 0.00 bar
Register Data 117 High = 0x00 Register Data 117 Low = 0x00	⇒ Process Pressure Sample 18: 0 ⇒ 0.00 bar
Register Data 118 Low = 0x03 Register Data 118 High = 0xE8	⇒ Position Sample 18: 1000 ⇒ 100.0 %
Register Data 119 Low = 0x00 Register Data 119 High = 0x00	⇒ P1-P2 Sample 18: 0 ⇒ 0.00 bar
Register Data 120 High = 0x01 Register Data 120 Low = 0x63	⇒ P1 Sample 19: 355 ⇒ 3.55 bar
Register Data 121 High = 0x00 Register Data 121 Low = 0x00	⇒ P2 Sample 19: 0 ⇒ 0.00 bar
Register Data 122 High = 0x00 Register Data 122 Low = 0x00	⇒ Process Pressure Sample 19: 0 ⇒ 0.00 bar
Register Data 123 Low = 0x03 Register Data 123 High = 0xE8	⇒ Position Sample 19: 1000 ⇒ 100.0 %
Register Data 124 Low = 0x00 Register Data 124 High = 0x00	⇒ P1-P2 Sample 19: 0 ⇒ 0.00 bar

To read the other samples, it's necessary to send Function Code 20 with different "Record Number" and "Register Length".

Example Requests List to read a complete curve by Function Code 20

Record Number	Register Length	Description
0x0000	0x19	25 Registers, Curve Data Header
0x0019	0x64	100 Registers, Curve Samples 0 – 19
0x007D	0x64	100 Registers, Curve Samples 20 – 39
0x00E1	0x64	100 Registers, Curve Samples 40 – 59
0x0145	0x64	100 Registers, Curve Samples 60 – 79
0x01A9	0x64	100 Registers, Curve Samples 80 – 99
0x020D	0x64	100 Registers, Curve Samples 100 – 119
0x0271	0x64	100 Registers, Curve Samples 120 – 139
0x02D5	0x64	100 Registers, Curve Samples 140 – 159
0x0339	0x64	100 Registers, Curve Samples 160 – 179
0x039D	0x64	100 Registers, Curve Samples 180 – 199
0x0401	0x64	100 Registers, Curve Samples 200 – 219
0x0465	0x64	100 Registers, Curve Samples 220 – 239
0x04C9	0x64	100 Registers, Curve Samples 240 – 259
0x052D	0x64	100 Registers, Curve Samples 260 – 279
0x0591	0x64	100 Registers, Curve Samples 280 – 299
0x05F5	0x64	100 Registers, Curve Samples 300 – 319
0x0659	0x64	100 Registers, Curve Samples 320 – 339
0x06BD	0x37	100 Registers, Curve Samples 340 – 350

5.4 Exception Codes

When a master sends a request to a slave, it expects a response. The following cases may occur:

- The slave receives the request and returns the normal response
- The slave does not receive the request and no response is returned. In this case the master waits for a certain time (timeout) and then it restarts with a new request.
- The slave receives the request but it detects a communication error (CRC). In this case the slave does not return a response; the master waits for a certain time (timeout) and then it restarts with a new request.
- The slave receives a request without communication errors, but it cannot process the data. In this case the slave returns an Exception Error message that describes the error.

IMVS2000v2 MODBUS RTU Interface has implemented the following Exception Codes:

Exception Code	Name	Description
01	Illegal Function Code	The function code requested is not supported in the slave device selected.
02	Illegal Data Address	The data address contained in the request message is not allowable in the slave device, or the combination of reference number and transfer length is invalid.
03	Illegal Data Value	A value contained in the request data field is not valid for the slave device.
04	Slave Device Failure	An error occurred while the slave device was performing the action requested by the request.
06	Slave Device Busy	The slave device is busy. The master should retransmit the request later.

5.5 Holding Registers Map

Address	Description	Min Value	Max Value	R/W	Notes
0	Position	-1000	1500	R	1000 = 100,0%
1	Position Request	0	1000	R	1000 = 100,0%
2	Pressure 1			R	See section 5.5.1 for details
3	Pressure 2			R	See section 5.5.1 for details
4	Process Pressure			R	See section 5.5.2 for details
5	Number of Alarms Active	0	65535	R	
6	Reserved - Not Used	0	65535	R	
7	Reserved - Not Used	0	65535	R	
8	Reserved - Not Used	0	65535	R	
9	Reserved - Not Used	0	65535	R	
10	Reserved - Not Used	0	65535	R	
11	Reserved - Not Used	0	65535	R	
12	Reserved - Not Used	0	65535	R	
13	Reserved - Not Used	0	65535	R	
14	Reserved - Not Used	0	65535	R	
15	Reserved - Not Used	0	65535	R	
16	Reserved - Not Used	0	65535	R	
17	Reserved - Not Used	0	65535	R	
18	Reserved - Not Used	0	65535	R	
19	Reserved - Not Used	0	65535	R	
20	Device Tag Name (1/8)			RW	ASCII
21	Device Tag Name (2/8)			RW	ASCII
22	Device Tag Name (3/8)			RW	ASCII
23	Device Tag Name (4/8)			RW	ASCII
24	Device Tag Name (5/8)			RW	ASCII

Address	Description	Min Value	Max Value	R/W	Notes
25	Device Tag Name (6/8)			RW	ASCII
26	Device Tag Name (7/8)			RW	ASCII
27	Devive Tag Name (8/8)			RW	ASCII
28	Device Serial Number (1/10)			RW	ASCII
29	Device Serial Number (2/10)			RW	ASCII
30	Device Serial Number (3/10)			RW	ASCII
31	Device Serial Number (4/10)			RW	ASCII
32	Device Serial Number (5/10)			RW	ASCII
33	Device Serial Number (6/10)			RW	ASCII
34	Device Serial Number (7/10)			RW	ASCII
35	Device Serial Number (8/10)			RW	ASCII
36	Device Serial Number (9/10)			RW	ASCII
37	Device Serial Number (10/10)			RW	ASCII
38	Device Date of Manufacturing (dd/mm)	0x0101	0x3112	RW	BCD Format
39	Device Date of Manufacturing (yyyy)	0x2014	0x2099	RW	BCD Format
40	SW Logic Revision (1/4)			R	ASCII
41	SW Logic Revision (2/4)			R	ASCII
42	SW Logic Revision (3/4)			R	ASCII
43	SW Logic Revision (4/4)			R	ASCII
44	SW Display Revision (1/4)			R	ASCII
45	SW Display Revision (2/4)			R	ASCII
46	SW Display Revision (3/4)			R	ASCII
47	SW Display Revision (4/4)			R	ASCII
48	Actuator Manufacturer (1/6)			RW	ASCII
49	Actuator Manufacturer (2/6)			RW	ASCII
50	Actuator Manufacturer (3/6)			RW	ASCII
51	Actuator Manufacturer (4/6)			RW	ASCII
52	Actuator Manufacturer (5/6)			RW	ASCII

Address	Description	Min Value	Max Value	R/W	Notes
53	Actuator Manufacturer (6/6)			RW	ASCII
54	Actuator Model (1/10)			RW	ASCII
55	Actuator Model (2/10)			RW	ASCII
56	Actuator Model (3/10)			RW	ASCII
57	Actuator Model (4/10)			RW	ASCII
58	Actuator Model (5/10)			RW	ASCII
59	Actuator Model (6/10)			RW	ASCII
60	Actuator Model (7/10)			RW	ASCII
61	Actuator Model (8/10)			RW	ASCII
62	Actuator Model (9/10)			RW	ASCII
63	Actuator Model (10/10)			RW	ASCII
64	Actuator Tag (1/10)			RW	ASCII
65	Actuator Tag (2/10)			RW	ASCII
66	Actuator Tag (3/10)			RW	ASCII
67	Actuator Tag (4/10)			RW	ASCII
68	Actuator Tag (5/10)			RW	ASCII
69	Actuator Tag (6/10)			RW	ASCII
70	Actuator Tag (7/10)			RW	ASCII
71	Actuator Tag (8/10)			RW	ASCII
72	Actuator Tag (9/10)			RW	ASCII
73	Actuator Tag (10/10)			RW	ASCII
74	Actuator Serial Number (1/10)			RW	ASCII
75	Actuator Serial Number (2/10)			RW	ASCII
76	Actuator Serial Number (3/10)			RW	ASCII
77	Actuator Serial Number (4/10)			RW	ASCII
78	Actuator Serial Number (5/10)			RW	ASCII
79	Actuator Serial Number (6/10)			RW	ASCII
80	Actuator Serial Number (7/10)			RW	ASCII

Address	Description	Min Value	Max Value	R/W	Notes
81	Actuator Serial Number (8/10)			RW	ASCII
82	Actuator Serial Number (9/10)			RW	ASCII
83	Actuator Serial Number (10/10)			RW	ASCII
84	Actuator Pressure Size (1/5)			RW	ASCII
85	Actuator Pressure Size (2/5)			RW	ASCII
86	Actuator Pressure Size (3/5)			RW	ASCII
87	Actuator Pressure Size (4/5)			RW	ASCII
88	Actuator Pressure Size (5/5)			RW	ASCII
89	Actuator Date of Manufacturing (dd/mm)	0x0101	0x3112	RW	BCD Format
90	Actuator Date of Manufacturing (yyyy)	0x2014	0x2099	RW	BCD Format
91	Valve Manufacturer (1/6)			RW	ASCII
92	Valve Manufacturer (2/6)			RW	ASCII
93	Valve Manufacturer (3/6)			RW	ASCII
94	Valve Manufacturer (4/6)			RW	ASCII
95	Valve Manufacturer (5/6)			RW	ASCII
96	Valve Manufacturer (6/6)			RW	ASCII
97	Valve Model (1/10)			RW	ASCII
98	Valve Model (2/10)			RW	ASCII
99	Valve Model (3/10)			RW	ASCII
100	Valve Model (4/10)			RW	ASCII
101	Valve Model (5/10)			RW	ASCII
102	Valve Model (6/10)			RW	ASCII
103	Valve Model (7/10)			RW	ASCII
104	Valve Model (8/10)			RW	ASCII
105	Valve Model (9/10)			RW	ASCII
106	Valve Model (10/10)			RW	ASCII
107	Valve Tag (1/10)			RW	ASCII
108	Valve Tag (2/10)			RW	ASCII

Address	Description	Min Value	Max Value	R/W	Notes
109	Valve Tag (3/10)			RW	ASCII
110	Valve Tag (4/10)			RW	ASCII
111	Valve Tag (5/10)			RW	ASCII
112	Valve Tag (6/10)			RW	ASCII
113	Valve Tag (7/10)			RW	ASCII
114	Valve Tag (8/10)			RW	ASCII
115	Valve Tag (9/10)			RW	ASCII
116	Valve Tag (10/10)			RW	ASCII
117	Valve Serial Number (1/10)			RW	ASCII
118	Valve Serial Number (2/10)			RW	ASCII
119	Valve Serial Number (3/10)			RW	ASCII
120	Valve Serial Number (4/10)			RW	ASCII
121	Valve Serial Number (5/10)			RW	ASCII
122	Valve Serial Number (6/10)			RW	ASCII
123	Valve Serial Number (7/10)			RW	ASCII
124	Valve Serial Number (8/10)			RW	ASCII
125	Valve Serial Number (9/10)			RW	ASCII
126	Valve Serial Number (10/10)			RW	ASCII
127	Valve Date of Manufacturing (dd/mm)	0x0101	0x3112	RW	BCD Format
128	Valve Date of Manufacturing (yyyy)	0x2014	0x2099	RW	BCD Format
129	Acting Mode	0	2	RW	0 = Single, 1 = Double, 2 = Double-S
130	Opening Rotation	0	1	R	0 = CW, 1 = CCW
131	Fail Action	0	1	RW	0 = CL, 1 = OP
132	SOVs Quantity	0	2	RW	0 = Simplex, 1 = Series, 2 = Parallel
133	Pressure Sensor 1-2	0	6	R	See section 5.5.3 for details
134	Process Sensor	0	6	R	See section 5.5.3 for details
135	Reserved	0	65535	R	
136	Reserved	0	65535	R	

Address	Description	Min Value	Max Value	R/W	Notes
137	Relay A Command	0	1	RW	0 = Not Active, 1 = Active
138	Relay B Command	0	1	RW	0 = Not Active, 1 = Active
139	Signature Enabled	0	1	RW	0 = No, 1 = Yes
140	Open Position Hysteresis	0	900	RW	10 = 1,0%
141	Closed Position Hysteresis	0	900	RW	10 = 1,0%
142	Opening Time Hysteresis	0	200	RW	100 = 100%
143	Closing Time Hysteresis	0	200	RW	100 = 100%
144	FST Pressure Hysteresis	0	100	RW	100 = 100%
145	High Pressure Limit	0	5800	RW	
146	Low Pressure Limit	0	5800	RW	
147	High Process Pressure Limit	0	5800	RW	
148	Low Process Pressure Limit	0	5800	RW	
149	FST Cycle Limit	1	100000	RW	MSB
150	FST Cycle Limit			RW	LSB
151	FST Cycle Count	0	100000	RW	MSB
152	FST Cycle Count			RW	LSB
153	FST Absolute Count	0	1000000	R	MSB
154	FST Absolute Count			R	LSB
155	PST Enabled	0	1	RW	0 = No, 1 = Yes
156	PST Set Point	50	950	RW	500 = 50,0%
157	PST Position Hysteresis	0	1000	RW	1000 = 100,0%
158	PST Pressure Hysteresis	0	100	RW	100 = 100%
159	PST Time Hysteresis	0	200	RW	100 = 100%
160	PST Series SOVs	0	1	RW	0 = One, 1 = Both
161	PST Cycle Limit	1	100000	RW	MSB
162	PST Cycle Limit			RW	LSB
163	PST Cycle Count	0	100000	RW	MSB
164	PST Cycle Count			RW	LSB

Address	Description	Min Value	Max Value	R/W	Notes
165	PST Absolute Count	0	1000000	R	MSB
166	PST Absolute Count			R	LSB
167	Automatic PST Enabled	0	1	RW	0 = No, 1 = Yes
168	Automatic PST Period	1	365	RW	days
169	Automatic PST Date (dd/mm)	0x0101	0x3112	RW	BCD Format
170	Automatic PST Date (yyyy)	0x2014	0x2099	RW	BCD Format
171	Automatic PST Time (hh:mm)	0x0000	0x2359	RW	BCD Format
172	Calibration	0	1	RW	1 = Execute Command
173	Calibration Date (dd/mm)	0x0101	0x3112	R	BCD Format
174	Calibration Date (yyyy)	0x2014	0x2099	R	BCD Format
175	Calibration Time (hh:mm)	0x0000	0x2359	R	BCD Format
176	Calibration Status	0	4	R	0 = Not Done, 1 = Passed, 2 = Failed, 3 = Progress, 4 = Conf. Err.
177	Calibration Enabled	0	1	RW	0 = No, 1 = Yes
178	Baseline Signature	0	1	RW	1 = Execute Command
179	Maintenance Signature	0	1	RW	1 = Execute Command
180	Opening Calculated Time	0	20000	R	800 = 80.0 sec.
181	Opening Maximum Time	0	20000	RW	1200 = 120.0 sec.
182	Closing Calculated Time	0	20000	R	800 = 80.0 sec.
183	Closing Maximum Time	0	20000	RW	1200 = 120.0 sec.
184	Baseline Signature Status	0	4	R	0 = Not Done, 1 = Passed, 2 = Failed, 3 = Progress, 4 = Conf. Err.
185	Baseline Signature Date (dd/mm)	0x0101	0x3112	R	BCD Format
186	Baseline Signature Date (yyyy)	0x2014	0x2099	R	BCD Format
187	Baseline Signature Time (hh:mm)	0x0000	0x2359	R	BCD Format
188	Opening Status	0	1	R	0 = Failed, 1 = Passed
189	Closing Status	0	1	R	0 = Failed, 1 = Passed
190	Maintenance Signature Status	0	4	R	0 = Not Done, 1 = Passed, 2 = Failed, 3 = Progress, 4 = Conf. Err.

Address	Description	Min Value	Max Value	R/W	Notes
191	Maintenance Signature Date (dd/mm)	0x0101	0x3112	R	BCD Format
192	Maintenance Signature Date (yyyy)	0x2014	0x2099	R	BCD Format
193	Maintenance Signature Time (hh:mm)	0x0000	0x2359	R	BCD Format
194	FST Stored	0	50	R	
195	FST ID	1	50	RW	
196	FST Info - FST Type	0	1	R	0 = Opening, 1 = Closing
197	FST Info - FST Source	0	3	R	0 = Baseline, 1 = Maintenance, 2 = DI, 3 = External
198	FST Info - FST Status	0	1	R	0 = Failed, 1 = Passed
199	FST Info - FST Count			R	MSB
200	FST Info - FST Count			R	LSB
201	FST Info - FST Date (dd/mm)	0x0101	0x3112	R	BCD Format
202	FST Info - FST Date (yyyy)	0x2014	0x2099	R	BCD Format
203	FST Info - FST Time (hh:mm)	0x0000	0x2359	R	BCD Format
204	FST Info - FST Break Time	0	50000	R	MSB
205	FST Info - FST Break Time			R	LSB (800 = 8.00 sec.)
206	FST Info - FST Break Pressure			R	See section 5.5.1 for details
207	FST Info - FST Travel Time	0	50000	R	MSB
208	FST Info - FST Travel Time			R	LSB (800 = 8.00 sec.)
209	Baseline Opening Break Time	0	50000	R	800 = 8.00 sec.
210	Maintenance Opening Break Time	0	50000	R	800 = 8.00 sec.
211	Baseline Opening Travel Time	0	50000	R	800 = 8.00 sec.
212	Maintenance Opening Travel Time	0	50000	R	800 = 8.00 sec.
213	Baseline Opening Break Pressure			R	See section 5.5.1 for details
214	Maintenance Opening Break Pressure			R	See section 5.5.1 for details
215	Baseline Closing Break Time	0	50000	R	800 = 8.00 sec.
216	Maintenance Closing Break Time	0	50000	R	800 = 8.00 sec.
217	Baseline Closing Travel Time	0	50000	R	800 = 8.00 sec.

Address	Description	Min Value	Max Value	R/W	Notes
218	Maintenance Closing Travel Time	0	50000	R	800 = 8.00 sec.
219	Baseline Closing Break Pressure			R	See section 5.5.1 for details
220	Maintenance Closing Break Pressure			R	See section 5.5.1 for details
221	Baseline PST	0	1	RW	1 = Execute Command
222	Manual PST	0	1	RW	1 = Execute Command
223	PST Set Point	50	950	R	1000 = 100.0 %
224	Baseline PST Calculated Time	0	20000	R	800 = 80.0 sec.
225	Baseline PST Maximum Time	0	20000	RW	1200 = 120.0 sec.
226	Baseline PST Status	0	4	R	0 = Failed, 1 = Passed, 2 = Progress, 3 = Not Done, 4 = Conf. Err.
227	Baseline PST Date (dd/mm)	0x0101	0x3112	R	BCD Format
228	Baseline PST Date (yyyy)	0x2014	0x2099	R	BCD Format
229	Baseline PST Time (hh:mm)	0x0000	0x2359	R	BCD Format
230	Manual PST Status	0	4	R	0 = Not Done, 1 = Passed, 2 = Failed, 3 = Progress, 4 = Conf. Err.
231	Manual PST Date (dd/mm)	0x0101	0x3112	R	BCD Format
232	Manual PST Date (yyyy)	0x2014	0x2099	R	BCD Format
233	Manual PST Time (hh:mm)	0x0000	0x2359	R	BCD Format
234	PST Stored	0	50	R	
235	PST ID	1	50	RW	
236	PST Info - PST Set Point	0	1000	R	1000 = 100.0 %
237	PST Info - PST Source	0	2	R	0 = Baseline, 1 = Maintenance, 2 = DI
238	PST Info - PST Status	0	1	R	0 = Failed, 1 = Passed
239	PST Info - PST Count			R	MSB
240	PST Info - PST Count			R	LSB
241	PST Info - PST Date (dd/mm)	0x0101	0x3112	R	BCD Format
242	PST Info - PST Date (yyyy)	0x2014	0x2099	R	BCD Format
243	PST Info - PST Time (hh:mm)	0x0000	0x2359	R	BCD Format

Address	Description	Min Value	Max Value	R/W	Notes
244	PST Info - PST Break Time	0	50000	R	MSB
245	PST Info - PST Break Time			R	LSB (800 = 8.00 sec.)
246	PST Info - Break Pressure			R	See section 5.5.1 for details
247	PST Info - Travel Time	0	50000	R	MSB
248	PST Info - Travel Time			R	LSB (800 = 8.00 sec.)
249	Baseline PST Break Time	0	50000	R	800 = 8.00 sec.
250	Manual PST Break Time	0	50000	R	800 = 8.00 sec.
251	Baseline PST Travel Time	0	50000	R	800 = 8.00 sec.
252	Manual PST Travel Time	0	50000	R	800 = 8.00 sec.
253	Baseline PST Break Pressure			R	See section 5.5.1 for details
254	Manual PST Break Pressure			R	See section 5.5.1 for details
255	Current Date (dd/mm)	0x0101	0x3112	RW	BCD Format
256	Current Date (yyyy)	0x2014	0x2099	RW	BCD Format
257	Current Time (00:hh)	0x0000	0x0023	RW	BCD Format
258	Current Time (mm:ss)	0x0000	0x5959	RW	BCD Format
259	Next Maintenance Date (dd/mm)	0x0101	0x3112	RW	BCD Format
260	Next Maintenance Date (yyyy)	0x2014	0x2099	RW	BCD Format
261	Common Failure Alarm Status	0	1	R	0 = Not Active, 1 = Active
262	Alarms Status 1	0	65535	R	See section 5.5.4 for details
263	Alarms Status 2	0	65535	R	See section 5.5.5 for details
264	Alarms Status 3	0	65535	R	See section 5.5.6 for details
265	Alarm Log 1 - ID Alarm	0	47	R	See section 5.5.7 for details
266	Alarm Log 1 - Status	0	1	R	0 = Cleared on, 1 = Activated on
267	Alarm Log 1 - Date (dd/mm)	0x0101	0x3112	R	BCD Format
268	Alarm Log 1 - Date (yyyy)	0x2014	0x2099	R	BCD Format
269	Alarm Log 1 - Time (hh:mm)	0x0000	0x2359	R	BCD Format
270	Alarm Log 2 - ID Alarm	0	47	R	See section 5.5.7 for details
271	Alarm Log 2 - Status	0	1	R	0 = Cleared on, 1 = Activated on

Address	Description	Min Value	Max Value	R/W	Notes
272	Alarm Log 2 - Date (dd/mm)	0x0101	0x3112	R	BCD Format
273	Alarm Log 2 - Date (yyyy)	0x2014	0x2099	R	BCD Format
274	Alarm Log 2 - Time (hh:mm)	0x0000	0x2359	R	BCD Format
275	Alarm Log 2 - ID Alarm	0	47	R	See section 5.5.7 for details
276	Alarm Log 3 - Status	0	1	R	0 = Cleared on, 1 = Activated on
277	Alarm Log 3 - Date (dd/mm)	0x0101	0x3112	R	BCD Format
278	Alarm Log 3 - Date (yyyy)	0x2014	0x2099	R	BCD Format
279	Alarm Log 3 - Time (hh:mm)	0x0000	0x2359	R	BCD Format
280	Alarm Log 4 - ID Alarm	0	47	R	See section 5.5.7 for details
281	Alarm Log 4 - Status	0	1	R	0 = Cleared on, 1 = Activated on
282	Alarm Log 4 - Date (dd/mm)	0x0101	0x3112	R	BCD Format
283	Alarm Log 4 - Date (yyyy)	0x2014	0x2099	R	BCD Format
284	Alarm Log 4 - Time (hh:mm)	0x0000	0x2359	R	BCD Format
285	Alarm Log 5 - ID Alarm	0	47	R	See section 5.5.7 for details
286	Alarm Log 5 - Status	0	1	R	0 = Cleared on, 1 = Activated on
287	Alarm Log 5 - Date (dd/mm)	0x0101	0x3112	R	BCD Format
288	Alarm Log 5 - Date (yyyy)	0x2014	0x2099	R	BCD Format
289	Alarm Log 5 - Time (hh:mm)	0x0000	0x2359	R	BCD Format
290	Alarm Log 6 - ID Alarm	0	47	R	See section 5.5.7 for details
291	Alarm Log 6 - Status	0	1	R	0 = Cleared on, 1 = Activated on
292	Alarm Log 6 - Date (dd/mm)	0x0101	0x3112	R	BCD Format
293	Alarm Log 6 - Date (yyyy)	0x2014	0x2099	R	BCD Format
294	Alarm Log 6 - Time (hh:mm)	0x0000	0x2359	R	BCD Format
295	Alarm Log 7 - ID Alarm	0	47	R	See section 5.5.7 for details
296	Alarm Log 7 - Status	0	1	R	0 = Cleared on, 1 = Activated on
297	Alarm Log 7 - Date (dd/mm)	0x0101	0x3112	R	BCD Format
298	Alarm Log 7 - Date (yyyy)	0x2014	0x2099	R	BCD Format
299	Alarm Log 7 - Time (hh:mm)	0x0000	0x2359	R	BCD Format

Address	Description	Min Value	Max Value	R/W	Notes
300	Alarm Log 8 - ID Alarm	0	47	R	See section 5.5.7 for details
301	Alarm Log 8 - Status	0	1	R	0 = Cleared on, 1 = Activated on
302	Alarm Log 8 - Date (dd/mm)	0x0101	0x3112	R	BCD Format
303	Alarm Log 8 - Date (yyyy)	0x2014	0x2099	R	BCD Format
304	Alarm Log 8 - Time (hh:mm)	0x0000	0x2359	R	BCD Format
305	Alarm Log 9 - ID Alarm	0	47	R	See section 5.5.7 for details
306	Alarm Log 9 - Status	0	1	R	0 = Cleared on, 1 = Activated on
307	Alarm Log 9 - Date (dd/mm)	0x0101	0x3112	R	BCD Format
308	Alarm Log 9 - Date (yyyy)	0x2014	0x2099	R	BCD Format
309	Alarm Log 9 - Time (hh:mm)	0x0000	0x2359	R	BCD Format
310	Alarm Log 10 - ID Alarm	0	47	R	See section 5.5.7 for details
311	Alarm Log 10 - Status	0	1	R	0 = Cleared on, 1 = Activated on
312	Alarm Log 10 - Date (dd/mm)	0x0101	0x3112	R	BCD Format
313	Alarm Log 10 - Date (yyyy)	0x2014	0x2099	R	BCD Format
314	Alarm Log 10 - Time (hh:mm)	0x0000	0x2359	R	BCD Format
315	Alarm Log 11 - ID Alarm	0	47	R	See section 5.5.7 for details
316	Alarm Log 11 - Status	0	1	R	0 = Cleared on, 1 = Activated on
317	Alarm Log 11 - Date (dd/mm)	0x0101	0x3112	R	BCD Format
318	Alarm Log 11 - Date (yyyy)	0x2014	0x2099	R	BCD Format
319	Alarm Log 11 - Time (hh:mm)	0x0000	0x2359	R	BCD Format
320	Alarm Log 12 - ID Alarm	0	47	R	See section 5.5.7 for details
321	Alarm Log 12 - Status	0	1	R	0 = Cleared on, 1 = Activated on
322	Alarm Log 12 - Date (dd/mm)	0x0101	0x3112	R	BCD Format
323	Alarm Log 12 - Date (yyyy)	0x2014	0x2099	R	BCD Format
324	Alarm Log 12 - Time (hh:mm)	0x0000	0x2359	R	BCD Format
325	Alarm Log 13 - ID Alarm	0	47	R	See section 5.5.7 for details
326	Alarm Log 13 - Status	0	1	R	0 = Cleared on, 1 = Activated on
327	Alarm Log 13 - Date (dd/mm)	0x0101	0x3112	R	BCD Format

Address	Description	Min Value	Max Value	R/W	Notes
328	Alarm Log 13 - Date (yyyy)	0x2014	0x2099	R	BCD Format
329	Alarm Log 13 - Time (hh:mm)	0x0000	0x2359	R	BCD Format
330	Alarm Log 14 - ID Alarm	0	47	R	See section 5.5.7 for details
331	Alarm Log 14 - Status	0	1	R	0 = Cleared on, 1 = Activated on
332	Alarm Log 14 - Date (dd/mm)	0x0101	0x3112	R	BCD Format
333	Alarm Log 14 - Date (yyyy)	0x2014	0x2099	R	BCD Format
334	Alarm Log 14 - Time (hh:mm)	0x0000	0x2359	R	BCD Format
335	Alarm Log 15 - ID Alarm	0	47	R	See section 5.5.7 for details
336	Alarm Log 15 - Status	0	1	R	0 = Cleared on, 1 = Activated on
337	Alarm Log 15 - Date (dd/mm)	0x0101	0x3112	R	BCD Format
338	Alarm Log 15 - Date (yyyy)	0x2014	0x2099	R	BCD Format
339	Alarm Log 15 - Time (hh:mm)	0x0000	0x2359	R	BCD Format
340	Alarm Log 16 - ID Alarm	0	47	R	See section 5.5.7 for details
341	Alarm Log 16 - Status	0	1	R	0 = Cleared on, 1 = Activated on
342	Alarm Log 16 - Date (dd/mm)	0x0101	0x3112	R	BCD Format
343	Alarm Log 16 - Date (yyyy)	0x2014	0x2099	R	BCD Format
344	Alarm Log 16 - Time (hh:mm)	0x0000	0x2359	R	BCD Format
345	Alarm Log 17 - ID Alarm	0	47	R	See section 5.5.7 for details
346	Alarm Log 17 - Status	0	1	R	0 = Cleared on, 1 = Activated on
347	Alarm Log 17 - Date (dd/mm)	0x0101	0x3112	R	BCD Format
348	Alarm Log 17 - Date (yyyy)	0x2014	0x2099	R	BCD Format
349	Alarm Log 17 - Time (hh:mm)	0x0000	0x2359	R	BCD Format
350	Alarm Log 18 - ID Alarm	0	47	R	See section 5.5.7 for details
351	Alarm Log 18 - Status	0	1	R	0 = Cleared on, 1 = Activated on
352	Alarm Log 18 - Date (dd/mm)	0x0101	0x3112	R	BCD Format
353	Alarm Log 18 - Date (yyyy)	0x2014	0x2099	R	BCD Format
354	Alarm Log 18 - Time (hh:mm)	0x0000	0x2359	R	BCD Format
355	Alarm Log 19 - ID Alarm	0	47	R	See section 5.5.7 for details

Address	Description	Min Value	Max Value	R/W	Notes
356	Alarm Log 19 - Status	0	1	R	0 = Cleared on, 1 = Activated on
357	Alarm Log 19 - Date (dd/mm)	0x0101	0x3112	R	BCD Format
358	Alarm Log 19 - Date (yyyy)	0x2014	0x2099	R	BCD Format
359	Alarm Log 19 - Time (hh:mm)	0x0000	0x2359	R	BCD Format
360	Alarm Log 20 - ID Alarm	0	47	R	See section 5.5.7 for details
361	Alarm Log 20 - Status	0	1	R	0 = Cleared on, 1 = Activated on
362	Alarm Log 20 - Date (dd/mm)	0x0101	0x3112	R	BCD Format
363	Alarm Log 20 - Date (yyyy)	0x2014	0x2099	R	BCD Format
364	Alarm Log 20 - Time (hh:mm)	0x0000	0x2359	R	BCD Format
365	Alarm Log 21 - ID Alarm	0	47	R	See section 5.5.7 for details
366	Alarm Log 21 - Status	0	1	R	0 = Cleared on, 1 = Activated on
367	Alarm Log 21 - Date (dd/mm)	0x0101	0x3112	R	BCD Format
368	Alarm Log 21 - Date (yyyy)	0x2014	0x2099	R	BCD Format
369	Alarm Log 21 - Time (hh:mm)	0x0000	0x2359	R	BCD Format
370	Alarm Log 22 - ID Alarm	0	47	R	See section 5.5.7 for details
371	Alarm Log 22 - Status	0	1	R	0 = Cleared on, 1 = Activated on
372	Alarm Log 22 - Date (dd/mm)	0x0101	0x3112	R	BCD Format
373	Alarm Log 22 - Date (yyyy)	0x2014	0x2099	R	BCD Format
374	Alarm Log 22 - Time (hh:mm)	0x0000	0x2359	R	BCD Format
375	Alarm Log 23 - ID Alarm	0	47	R	See section 5.5.7 for details
376	Alarm Log 23 - Status	0	1	R	0 = Cleared on, 1 = Activated on
377	Alarm Log 23 - Date (dd/mm)	0x0101	0x3112	R	BCD Format
378	Alarm Log 23 - Date (yyyy)	0x2014	0x2099	R	BCD Format
379	Alarm Log 23 - Time (hh:mm)	0x0000	0x2359	R	BCD Format
380	Alarm Log 24 - ID Alarm	0	47	R	See section 5.5.7 for details
381	Alarm Log 24 - Status	0	1	R	0 = Cleared on, 1 = Activated on
382	Alarm Log 24 - Date (dd/mm)	0x0101	0x3112	R	BCD Format
383	Alarm Log 24 - Date (yyyy)	0x2014	0x2099	R	BCD Format

Address	Description	Min Value	Max Value	R/W	Notes
384	Alarm Log 24 - Time (hh:mm)	0x0000	0x2359	R	BCD Format
385	Alarm Log 25 - ID Alarm	0	47	R	See section 5.5.7 for details
386	Alarm Log 25 - Status	0	1	R	0 = Cleared on, 1 = Activated on
387	Alarm Log 25 - Date (dd/mm)	0x0101	0x3112	R	BCD Format
388	Alarm Log 25 - Date (yyyy)	0x2014	0x2099	R	BCD Format
389	Alarm Log 25 - Time (hh:mm)	0x0000	0x2359	R	BCD Format
390	Alarm Log 26 - ID Alarm	0	47	R	See section 5.5.7 for details
391	Alarm Log 26 - Status	0	1	R	0 = Cleared on, 1 = Activated on
392	Alarm Log 26 - Date (dd/mm)	0x0101	0x3112	R	BCD Format
393	Alarm Log 26 - Date (yyyy)	0x2014	0x2099	R	BCD Format
394	Alarm Log 26 - Time (hh:mm)	0x0000	0x2359	R	BCD Format
395	Alarm Log 27 - ID Alarm	0	47	R	See section 5.5.7 for details
396	Alarm Log 27 - Status	0	1	R	0 = Cleared on, 1 = Activated on
397	Alarm Log 27 - Date (dd/mm)	0x0101	0x3112	R	BCD Format
398	Alarm Log 27 - Date (yyyy)	0x2014	0x2099	R	BCD Format
399	Alarm Log 27 - Time (hh:mm)	0x0000	0x2359	R	BCD Format
400	Alarm Log 28 - ID Alarm	0	47	R	See section 5.5.7 for details
401	Alarm Log 28 - Status	0	1	R	0 = Cleared on, 1 = Activated on
402	Alarm Log 28 - Date (dd/mm)	0x0101	0x3112	R	BCD Format
403	Alarm Log 28 - Date (yyyy)	0x2014	0x2099	R	BCD Format
404	Alarm Log 28 - Time (hh:mm)	0x0000	0x2359	R	BCD Format
405	Alarm Log 29 - ID Alarm	0	47	R	See section 5.5.7 for details
406	Alarm Log 29 - Status	0	1	R	0 = Cleared on, 1 = Activated on
407	Alarm Log 29 - Date (dd/mm)	0x0101	0x3112	R	BCD Format
408	Alarm Log 29 - Date (yyyy)	0x2014	0x2099	R	BCD Format
409	Alarm Log 29 - Time (hh:mm)	0x0000	0x2359	R	BCD Format
410	Alarm Log 30 - ID Alarm	0	47	R	See section 5.5.7 for details
411	Alarm Log 30 - Status	0	1	R	0 = Cleared on, 1 = Activated on

Address	Description	Min Value	Max Value	R/W	Notes
412	Alarm Log 30 - Date (dd/mm)	0x0101	0x3112	R	BCD Format
413	Alarm Log 30 - Date (yyyy)	0x2014	0x2099	R	BCD Format
414	Alarm Log 30 - Time (hh:mm)	0x0000	0x2359	R	BCD Format
415	Alarm Log 31 - ID Alarm	0	47	R	See section 5.5.7 for details
416	Alarm Log 31 - Status	0	1	R	0 = Cleared on, 1 = Activated on
417	Alarm Log 31 - Date (dd/mm)	0x0101	0x3112	R	BCD Format
418	Alarm Log 31 - Date (yyyy)	0x2014	0x2099	R	BCD Format
419	Alarm Log 31 - Time (hh:mm)	0x0000	0x2359	R	BCD Format
420	Alarm Log 32 - ID Alarm	0	47	R	See section 5.5.7 for details
421	Alarm Log 32 - Status	0	1	R	0 = Cleared on, 1 = Activated on
422	Alarm Log 32 - Date (dd/mm)	0x0101	0x3112	R	BCD Format
423	Alarm Log 32 - Date (yyyy)	0x2014	0x2099	R	BCD Format
424	Alarm Log 32 - Time (hh:mm)	0x0000	0x2359	R	BCD Format
425	Alarm Log 33 - ID Alarm	0	47	R	See section 5.5.7 for details
426	Alarm Log 33 - Status	0	1	R	0 = Cleared on, 1 = Activated on
427	Alarm Log 33 - Date (dd/mm)	0x0101	0x3112	R	BCD Format
428	Alarm Log 33 - Date (yyyy)	0x2014	0x2099	R	BCD Format
429	Alarm Log 33 - Time (hh:mm)	0x0000	0x2359	R	BCD Format
430	Alarm Log 34 - ID Alarm	0	47	R	See section 5.5.7 for details
431	Alarm Log 34 - Status	0	1	R	0 = Cleared on, 1 = Activated on
432	Alarm Log 34 - Date (dd/mm)	0x0101	0x3112	R	BCD Format
433	Alarm Log 34 - Date (yyyy)	0x2014	0x2099	R	BCD Format
434	Alarm Log 34 - Time (hh:mm)	0x0000	0x2359	R	BCD Format
435	Alarm Log 35 - ID Alarm	0	47	R	See section 5.5.7 for details
436	Alarm Log 35 - Status	0	1	R	0 = Cleared on, 1 = Activated on
437	Alarm Log 35 - Date (dd/mm)	0x0101	0x3112	R	BCD Format
438	Alarm Log 35 - Date (yyyy)	0x2014	0x2099	R	BCD Format
439	Alarm Log 35 - Time (hh:mm)	0x0000	0x2359	R	BCD Format

Address	Description	Min Value	Max Value	R/W	Notes
440	Alarm Log 36 - ID Alarm	0	47	R	See section 5.5.7 for details
441	Alarm Log 36 - Status	0	1	R	0 = Cleared on, 1 = Activated on
442	Alarm Log 36 - Date (dd/mm)	0x0101	0x3112	R	BCD Format
443	Alarm Log 36 - Date (yyyy)	0x2014	0x2099	R	BCD Format
444	Alarm Log 36 - Time (hh:mm)	0x0000	0x2359	R	BCD Format
445	Alarm Log 37 - ID Alarm	0	47	R	See section 5.5.7 for details
446	Alarm Log 37 - Status	0	1	R	0 = Cleared on, 1 = Activated on
447	Alarm Log 37 - Date (dd/mm)	0x0101	0x3112	R	BCD Format
448	Alarm Log 37 - Date (yyyy)	0x2014	0x2099	R	BCD Format
449	Alarm Log 37 - Time (hh:mm)	0x0000	0x2359	R	BCD Format
450	Alarm Log 38 - ID Alarm	0	47	R	See section 5.5.7 for details
451	Alarm Log 38 - Status	0	1	R	0 = Cleared on, 1 = Activated on
452	Alarm Log 38 - Date (dd/mm)	0x0101	0x3112	R	BCD Format
453	Alarm Log 38 - Date (yyyy)	0x2014	0x2099	R	BCD Format
454	Alarm Log 38 - Time (hh:mm)	0x0000	0x2359	R	BCD Format
455	Alarm Log 39 - ID Alarm	0	47	R	See section 5.5.7 for details
456	Alarm Log 39 - Status	0	1	R	0 = Cleared on, 1 = Activated on
457	Alarm Log 39 - Date (dd/mm)	0x0101	0x3112	R	BCD Format
458	Alarm Log 39 - Date (yyyy)	0x2014	0x2099	R	BCD Format
459	Alarm Log 39 - Time (hh:mm)	0x0000	0x2359	R	BCD Format
460	Alarm Log 40 - ID Alarm	0	47	R	See section 5.5.7 for details
461	Alarm Log 40 - Status	0	1	R	0 = Cleared on, 1 = Activated on
462	Alarm Log 40 - Date (dd/mm)	0x0101	0x3112	R	BCD Format
463	Alarm Log 40 - Date (yyyy)	0x2014	0x2099	R	BCD Format
464	Alarm Log 40 - Time (hh:mm)	0x0000	0x2359	R	BCD Format
465	Alarm Log 41 - ID Alarm	0	47	R	See section 5.5.7 for details
466	Alarm Log 41 - Status	0	1	R	0 = Cleared on, 1 = Activated on
467	Alarm Log 41 - Date (dd/mm)	0x0101	0x3112	R	BCD Format

Address	Description	Min Value	Max Value	R/W	Notes
468	Alarm Log 41 - Date (yyyy)	0x2014	0x2099	R	BCD Format
469	Alarm Log 41 - Time (hh:mm)	0x0000	0x2359	R	BCD Format
470	Alarm Log 42 - ID Alarm	0	47	R	See section 5.5.7 for details
471	Alarm Log 42 - Status	0	1	R	0 = Cleared on, 1 = Activated on
472	Alarm Log 42 - Date (dd/mm)	0x0101	0x3112	R	BCD Format
473	Alarm Log 42 - Date (yyyy)	0x2014	0x2099	R	BCD Format
474	Alarm Log 42 - Time (hh:mm)	0x0000	0x2359	R	BCD Format
475	Alarm Log 43 - ID Alarm	0	47	R	See section 5.5.7 for details
476	Alarm Log 43 - Status	0	1	R	0 = Cleared on, 1 = Activated on
477	Alarm Log 43 - Date (dd/mm)	0x0101	0x3112	R	BCD Format
478	Alarm Log 43 - Date (yyyy)	0x2014	0x2099	R	BCD Format
479	Alarm Log 43 - Time (hh:mm)	0x0000	0x2359	R	BCD Format
480	Alarm Log 44 - ID Alarm	0	47	R	See section 5.5.7 for details
481	Alarm Log 44 - Status	0	1	R	0 = Cleared on, 1 = Activated on
482	Alarm Log 44 - Date (dd/mm)	0x0101	0x3112	R	BCD Format
483	Alarm Log 44 - Date (yyyy)	0x2014	0x2099	R	BCD Format
484	Alarm Log 44 - Time (hh:mm)	0x0000	0x2359	R	BCD Format
485	Alarm Log 45 - ID Alarm	0	47	R	See section 5.5.7 for details
486	Alarm Log 45 - Status	0	1	R	0 = Cleared on, 1 = Activated on
487	Alarm Log 45 - Date (dd/mm)	0x0101	0x3112	R	BCD Format
488	Alarm Log 45 - Date (yyyy)	0x2014	0x2099	R	BCD Format
489	Alarm Log 45 - Time (hh:mm)	0x0000	0x2359	R	BCD Format
490	Alarm Log 46 - ID Alarm	0	47	R	See section 5.5.7 for details
491	Alarm Log 46 - Status	0	1	R	0 = Cleared on, 1 = Activated on
492	Alarm Log 46 - Date (dd/mm)	0x0101	0x3112	R	BCD Format
493	Alarm Log 46 - Date (yyyy)	0x2014	0x2099	R	BCD Format
494	Alarm Log 46 - Time (hh:mm)	0x0000	0x2359	R	BCD Format
495	Alarm Log 47 - ID Alarm	0	47	R	See section 5.5.7 for details

Address	Description	Min Value	Max Value	R/W	Notes
496	Alarm Log 47 - Status	0	1	R	0 = Cleared on, 1 = Activated on
497	Alarm Log 47 - Date (dd/mm)	0x0101	0x3112	R	BCD Format
498	Alarm Log 47 - Date (yyyy)	0x2014	0x2099	R	BCD Format
499	Alarm Log 47 - Time (hh:mm)	0x0000	0x2359	R	BCD Format
500	Alarm Log 48 - ID Alarm	0	47	R	See section 5.5.7 for details
501	Alarm Log 48 - Status	0	1	R	0 = Cleared on, 1 = Activated on
502	Alarm Log 48 - Date (dd/mm)	0x0101	0x3112	R	BCD Format
503	Alarm Log 48 - Date (yyyy)	0x2014	0x2099	R	BCD Format
504	Alarm Log 48 - Time (hh:mm)	0x0000	0x2359	R	BCD Format
505	Alarm Log 49 - ID Alarm	0	47	R	See section 5.5.7 for details
506	Alarm Log 49 - Status	0	1	R	0 = Cleared on, 1 = Activated on
507	Alarm Log 49 - Date (dd/mm)	0x0101	0x3112	R	BCD Format
508	Alarm Log 49 - Date (yyyy)	0x2014	0x2099	R	BCD Format
509	Alarm Log 49 - Time (hh:mm)	0x0000	0x2359	R	BCD Format
510	Alarm Log 50 - ID Alarm	0	47	R	See section 5.5.7 for details
511	Alarm Log 50 - Status	0	1	R	0 = Cleared on, 1 = Activated on
512	Alarm Log 50 - Date (dd/mm)	0x0101	0x3112	R	BCD Format
513	Alarm Log 50 - Date (yyyy)	0x2014	0x2099	R	BCD Format
514	Alarm Log 50 - Time (hh:mm)	0x0000	0x2359	R	BCD Format
515	Clear Alarms List	0	1	RW	1 = Execute Command
516	Reset Alarms	0	1	RW	1 = Execute Command
517	PSCL Alarm Enabled	0	2	RW	0 = No, 1 = Alr, 2 = CFA
518	PSCT Alarm Enabled	0	2	RW	0 = No, 1 = Alr, 2 = CFA
519	PSSB Alarm Enabled	0	2	RW	0 = No, 1 = Alr, 2 = CFA
520	PSFB Alarm Enabled	0	2	RW	0 = No, 1 = Alr, 2 = CFA
521	PSST Alarm Enabled	0	2	RW	0 = No, 1 = Alr, 2 = CFA
522	PSFT Alarm Enabled	0	2	RW	0 = No, 1 = Alr, 2 = CFA
523	PSSP Alarm Enabled	0	2	RW	0 = No, 1 = Alr, 2 = CFA

Address	Description	Min Value	Max Value	R/W	Notes
524	PSSR Alarm Enabled	0	2	RW	0 = No, 1 = Alr, 2 = CFA
525	PSLB Alarm Enabled	0	2	RW	0 = No, 1 = Alr, 2 = CFA
526	PSHB Alarm Enabled	0	2	RW	0 = No, 1 = Alr, 2 = CFA
527	PSNM Alarm Enabled	1	2	RW	1 = Alr, 2 = CFA
528	PSA Alarm Enabled	0	2	RW	0 = No, 1 = Alr, 2 = CFA
529	PSB Alarm Enabled	0	2	RW	0 = No, 1 = Alr, 2 = CFA
530	SISA Alarm Enabled	0	2	RW	0 = No, 1 = Alr, 2 = CFA
531	SISB Alarm Enabled	0	2	RW	0 = No, 1 = Alr, 2 = CFA
532	OPOS Alarm Enabled	0	2	RW	0 = No, 1 = Alr, 2 = CFA
533	CPOS Alarm Enabled	0	2	RW	0 = No, 1 = Alr, 2 = CFA
534	LSP Alarm Enabled	0	2	RW	0 = No, 1 = Alr, 2 = CFA
535	HSP Alarm Enabled	0	2	RW	0 = No, 1 = Alr, 2 = CFA
536	LPP Alarm Enabled	0	2	RW	0 = No, 1 = Alr, 2 = CFA
537	HPP Alarm Enabled	0	2	RW	0 = No, 1 = Alr, 2 = CFA
538	OPNM Alarm Enabled	1	2	RW	1 = Alr, 2 = CFA
539	CLNM Alarm Enabled	1	2	RW	1 = Alr, 2 = CFA
540	OPCT Alarm Enabled	0	2	RW	0 = No, 1 = Alr, 2 = CFA
541	CLCT Alarm Enabled	0	2	RW	0 = No, 1 = Alr, 2 = CFA
542	FSCL Alarm Enabled	0	2	RW	0 = No, 1 = Alr, 2 = CFA
543	SOBT Alarm Enabled	0	2	RW	0 = No, 1 = Alr, 2 = CFA
544	FOBT Alarm Enabled	0	2	RW	0 = No, 1 = Alr, 2 = CFA
545	SOTT Alarm Enabled	0	2	RW	0 = No, 1 = Alr, 2 = CFA
546	FOTT Alarm Enabled	0	2	RW	0 = No, 1 = Alr, 2 = CFA
547	SCBT Alarm Enabled	0	2	RW	0 = No, 1 = Alr, 2 = CFA
548	FCBT Alarm Enabled	0	2	RW	0 = No, 1 = Alr, 2 = CFA
549	SCTT Alarm Enabled	0	2	RW	0 = No, 1 = Alr, 2 = CFA
550	FCTT Alarm Enabled	0	2	RW	0 = No, 1 = Alr, 2 = CFA
551	OHBP Alarm Enabled	0	2	RW	0 = No, 1 = Alr, 2 = CFA

Address	Description	Min Value	Max Value	R/W	Notes
552	OLBP Alarm Enabled	0	2	RW	0 = No, 1 = Alr, 2 = CFA
553	CHBP Alarm Enabled	0	2	RW	0 = No, 1 = Alr, 2 = CFA
554	CLBP Alarm Enabled	0	2	RW	0 = No, 1 = Alr, 2 = CFA
555	PS1 Alarm Enabled	0	2	RW	0 = No, 1 = Alr, 2 = CFA
556	PS2 Alarm Enabled	0	2	RW	0 = No, 1 = Alr, 2 = CFA
557	PPS Alarm Enabled	0	2	RW	0 = No, 1 = Alr, 2 = CFA
558	POS Alarm Enabled	1	2	RW	1 = Alr, 2 = CFA
559	BUS Alarm Enabled	0	2	RW	0 = No, 1 = Alr, 2 = CFA
560	MNT Alarm Enabled	0	2	RW	0 = No, 1 = Alr, 2 = CFA
561	Reserved	0	1	R	
562	Pressure Measurement Unit	0	1	RW	0 = bar, 1 = psi
563	Common Failure Alarm Mode	0	1	RW	0 = NO, 1 = NC
564	Open Close DO Mode	0	1	RW	0 = NO, 1 = NC
565	Reserved	0	65535	R	
566	Bluetooth Enabled	0	1	RW	0 = No, 1 = Yes
567	Manual FST Alarm Enabled	0	1	RW	0 = No, 1 = Yes
568	Reserved	0	65535	R	
569	Reserved	0	65535	R	
570	Reserved	0	65535	R	
571	Reserved	0	65535	R	
572	Reserved	0	65535	R	
573	Reserved	0	65535	R	
574	Reserved - Not Used	0	0	R	
575	Reserved - Not Used	0	0	R	
576	Reserved - Not Used	0	0	R	
577	Reserved - Not Used	0	0	R	
578	Modbus Address	1	247	RW	

Address	Description	Min Value	Max Value	R/W	Notes
579	Modbus Baud Rate	0	6	RW	0 = 600bps, 1 = 1200bps, 2 = 2400bps, 3 = 4800bps, 4 = 9600bps, 5 = 19200bps, 6 = 38400bps
580	Modbus Parity	0	2	RW	0 = ODD, 1 = EVEN, 2 = NONE
581	Modbus Termination	0	1	RW	0 = Not Active, 1 = Active
582	Modbus Enabled	0	1	RW	0 = Disabled, 1 = Enabled
583	Reserved - Not Used	0	0	R	
584	Reserved - Not Used	0	0	R	
585	Reserved - Not Used	0	0	R	
586	Reserved - Not Used	0	0	R	
587	Reserved - Not Used	0	0	R	
588	Reserved - Not Used	0	0	R	
589	Reserved - Not Used	0	0	R	
590	Reserved - Not Used	0	0	R	
591	Reserved - Not Used	0	0	R	
592	Reserved - Not Used	0	0	R	
593	Reserved - Not Used	0	0	R	
594	Reserved - Not Used	0	0	R	
595	Reserved - Not Used	0	0	R	
596	Reserved - Not Used	0	0	R	
597	Reserved - Not Used	0	0	R	
598	Reserved - Not Used	0	0	R	
599	Reserved - Not Used	0	0	R	
600	Reserved - Not Used	0	0	R	
601	Reserved - Not Used	0	0	R	
602	Reserved - Not Used	0	0	R	
603	Reserved - Not Used	0	0	R	
604	Reserved - Not Used	0	0	R	
605	Reserved - Not Used	0	0	R	

Address	Description	Min Value	Max Value	R/W	Notes
606	Reserved - Not Used	0	0	R	
607	Reserved - Not Used	0	0	R	
608	Reserved - Not Used	0	0	R	
609	Reserved - Not Used	0	0	R	
610	Reserved - Not Used	0	0	R	
611	Reserved - Not Used	0	0	R	
612	Reserved - Not Used	0	0	R	
613	Reserved - Not Used	0	0	R	
614	Reserved - Not Used	0	0	R	
615	Reserved - Not Used	0	0	R	
616	Reserved - Not Used	0	0	R	
617	Reserved - Not Used	0	0	R	
618	Reserved	0	65535	R	
619	Reserved	0	65535	R	
620	Reserved	0	65535	R	
621	Reserved	0	65535	R	
622	Reserved	0	65535	R	
623	Reserved	0	65535	R	
624	Reserved	1	65535	R	
625	Reserved	1	65535	R	
626	Reserved	0	65535	R	
627	Reserved	0	65535	R	
628	Reserved	0	65535	R	
629	Reserved	0	65535	R	
630	Reserved	0	65535	R	
631	Reserved	0	65535	R	
632	Reserved	0	65535	R	
633	Reserved	0	65535	R	

Address	Description	Min Value	Max Value	R/W	Notes
634	Reserved	0	65535	R	
635	Reserved	0	65535	R	
636	Reserved	0	65535	R	
637	Reserved	0	65535	R	
638	Reserved	0	65535	R	
639	Reserved	0	65535	R	
640	Reserved	0	65535	R	
641	Reserved	0	65535	R	
642	Reserved	0	65535	R	
643	DI SOV A Status	0	1	R	0 = Low, 1 = High
644	DI SOV B Status	0	1	R	0 = Low, 1 = High
645	DI PST Status	0	1	R	0 = Low, 1 = High
646	DI SIS A Status	0	1	R	0 = Low, 1 = High
647	DI SIS B Status	0	1	R	0 = Low, 1 = High
648	Reserved	0	65535	R	
649	Reserved	0	65535	R	
650	Reserved	0	65535	R	
651	Reserved	0	65535	R	
652	Reserved	0	65535	R	
653	Reserved	0	65535	R	
654	Reserved	0	65535	R	
655	Reserved	0	65535	R	
656	Reserved	0	65535	R	
657	Reserved	0	65535	R	
658	Reserved	0	65535	R	
659	Reserved	0	65535	R	
660	Reserved	0	65535	R	
661	Reserved	0	65535	R	

Address	Description	Min Value	Max Value	R/W	Notes
662	Reserved	0	65535	R	
663	Reserved	0	65535	R	
664	Reserved	0	65535	R	
665	Reserved	0	65535	R	
666	Reserved	0	65535	R	
667	Reserved	0	65535	R	
668	Reserved	0	65535	R	
669	Reserved	0	65535	R	
670	Reserved	0	65535	R	
671	Reserved	0	65535	R	
672	Reserved	0	65535	R	
673	Reserved	0	65535	R	
674	Reserved	0	65535	R	
675	Reserved	0	65535	R	
676	Reserved	0	65535	R	
677	Reserved	0	65535	R	
678	Reserved	0	65535	R	
679	Reserved	0	65535	R	
680	Reserved	0	65535	R	
681	Reserved	0	65535	R	
682	Reserved	0	65535	R	
683	Reserved	0	65535	R	
684	Reserved	0	65535	R	
685	Reserved	0	65535	R	
686	Reserved	0	65535	R	
687	Reserved	0	65535	R	
688	Reserved	0	65535	R	
689	Graph Type	0	1	RW	0 = FST, 1 = PST

Address	Description	Min Value	Max Value	R/W	Notes
690	Graph ID	1	50	RW	
691	Slot Address	1	20	RW	
692	Store Graph	1	1	RW	
693	Clear Slots	1	1	RW	1 = Execute Command
694	Slot 1 Type	0	3	R	0 = FST Close, 1 = FST Open, 2 = PST, 3 = Empty
695	Slot 1 Date (dd/mm)	0x0101	0x3112	R	BCD Format
696	Slot 1 Date (yyyy)	0x2014	0x2099	R	BCD Format
697	Slot 1 Time (hh:mm)	0x0000	0x2359	R	BCD Format
698	Slot 2 Type	0	3	R	0 = FST Close, 1 = FST Open, 2 = PST, 3 = Empty
699	Slot 2 Date (dd/mm)	0x0101	0x3112	R	BCD Format
700	Slot 2 Date (yyyy)	0x2014	0x2099	R	BCD Format
701	Slot 2 Time (hh:mm)	0x0000	0x2359	R	BCD Format
702	Slot 3 Type	0	3	R	0 = FST Close, 1 = FST Open, 2 = PST, 3 = Empty
703	Slot 3 Date (dd/mm)	0x0101	0x3112	R	BCD Format
704	Slot 3 Date (yyyy)	0x2014	0x2099	R	BCD Format
705	Slot 3 Time (hh:mm)	0x0000	0x2359	R	BCD Format
706	Slot 4 Type	0	3	R	0 = FST Close, 1 = FST Open, 2 = PST, 3 = Empty
707	Slot 4 Date (dd/mm)	0x0101	0x3112	R	BCD Format
708	Slot 4 Date (yyyy)	0x2014	0x2099	R	BCD Format
709	Slot 4 Time (hh:mm)	0x0000	0x2359	R	BCD Format
710	Slot 5 Type	0	3	R	0 = FST Close, 1 = FST Open, 2 = PST, 3 = Empty
711	Slot 5 Date (dd/mm)	0x0101	0x3112	R	BCD Format
712	Slot 5 Date (yyyy)	0x2014	0x2099	R	BCD Format
713	Slot 5 Time (hh:mm)	0x0000	0x2359	R	BCD Format
714	Slot 6 Type	0	3	R	0 = FST Close, 1 = FST Open, 2 = PST, 3 = Empty
715	Slot 6 Date (dd/mm)	0x0101	0x3112	R	BCD Format
716	Slot 6 Date (yyyy)	0x2014	0x2099	R	BCD Format
717	Slot 6 Time (hh:mm)	0x0000	0x2359	R	BCD Format

Address	Description	Min Value	Max Value	R/W	Notes
718	Slot 7 Type	0	3	R	0 = FST Close, 1 = FST Open, 2 = PST, 3 = Empty
719	Slot 7 Date (dd/mm)	0x0101	0x3112	R	BCD Format
720	Slot 7 Date (yyyy)	0x2014	0x2099	R	BCD Format
721	Slot 7 Time (hh:mm)	0x0000	0x2359	R	BCD Format
722	Slot 8 Type	0	3	R	0 = FST Close, 1 = FST Open, 2 = PST, 3 = Empty
723	Slot 8 Date (dd/mm)	0x0101	0x3112	R	BCD Format
724	Slot 8 Date (yyyy)	0x2014	0x2099	R	BCD Format
725	Slot 8 Time (hh:mm)	0x0000	0x2359	R	BCD Format
726	Slot 9 Type	0	3	R	0 = FST Close, 1 = FST Open, 2 = PST, 3 = Empty
727	Slot 9 Date (dd/mm)	0x0101	0x3112	R	BCD Format
728	Slot 9 Date (yyyy)	0x2014	0x2099	R	BCD Format
729	Slot 9 Time (hh:mm)	0x0000	0x2359	R	BCD Format
730	Slot 10 Type	0	3	R	0 = FST Close, 1 = FST Open, 2 = PST, 3 = Empty
731	Slot 10 Date (dd/mm)	0x0101	0x3112	R	BCD Format
732	Slot 10 Date (yyyy)	0x2014	0x2099	R	BCD Format
733	Slot 10 Time (hh:mm)	0x0000	0x2359	R	BCD Format
734	Slot 11 Type	0	3	R	0 = FST Close, 1 = FST Open, 2 = PST, 3 = Empty
735	Slot 11 Date (dd/mm)	0x0101	0x3112	R	BCD Format
736	Slot 11 Date (yyyy)	0x2014	0x2099	R	BCD Format
737	Slot 11 Time (hh:mm)	0x0000	0x2359	R	BCD Format
738	Slot 12 Type	0	3	R	0 = FST Close, 1 = FST Open, 2 = PST, 3 = Empty
739	Slot 12 Date (dd/mm)	0x0101	0x3112	R	BCD Format
740	Slot 12 Date (yyyy)	0x2014	0x2099	R	BCD Format
741	Slot 12 Time (hh:mm)	0x0000	0x2359	R	BCD Format
742	Slot 13 Type	0	3	R	0 = FST Close, 1 = FST Open, 2 = PST, 3 = Empty
743	Slot 13 Date (dd/mm)	0x0101	0x3112	R	BCD Format
744	Slot 13 Date (yyyy)	0x2014	0x2099	R	BCD Format
745	Slot 13 Time (hh:mm)	0x0000	0x2359	R	BCD Format

Address	Description	Min Value	Max Value	R/W	Notes
746	Slot 14 Type	0	3	R	0 = FST Close, 1 = FST Open, 2 = PST, 3 = Empty
747	Slot 14 Date (dd/mm)	0x0101	0x3112	R	BCD Format
748	Slot 14 Date (yyyy)	0x2014	0x2099	R	BCD Format
749	Slot 14 Time (hh:mm)	0x0000	0x2359	R	BCD Format
750	Slot 15 Type	0	3	R	0 = FST Close, 1 = FST Open, 2 = PST, 3 = Empty
751	Slot 15 Date (dd/mm)	0x0101	0x3112	R	BCD Format
752	Slot 15 Date (yyyy)	0x2014	0x2099	R	BCD Format
753	Slot 15 Time (hh:mm)	0x0000	0x2359	R	BCD Format
754	Slot 16 Type	0	3	R	0 = FST Close, 1 = FST Open, 2 = PST, 3 = Empty
755	Slot 16 Date (dd/mm)	0x0101	0x3112	R	BCD Format
756	Slot 16 Date (yyyy)	0x2014	0x2099	R	BCD Format
757	Slot 16 Time (hh:mm)	0x0000	0x2359	R	BCD Format
758	Slot 17 Type	0	3	R	0 = FST Close, 1 = FST Open, 2 = PST, 3 = Empty
759	Slot 17 Date (dd/mm)	0x0101	0x3112	R	BCD Format
760	Slot 17 Date (yyyy)	0x2014	0x2099	R	BCD Format
761	Slot 17 Time (hh:mm)	0x0000	0x2359	R	BCD Format
762	Slot 18 Type	0	3	R	0 = FST Close, 1 = FST Open, 2 = PST, 3 = Empty
763	Slot 18 Date (dd/mm)	0x0101	0x3112	R	BCD Format
764	Slot 18 Date (yyyy)	0x2014	0x2099	R	BCD Format
765	Slot 18 Time (hh:mm)	0x0000	0x2359	R	BCD Format
766	Slot 19 Type	0	3	R	0 = FST Close, 1 = FST Open, 2 = PST, 3 = Empty
767	Slot 19 Date (dd/mm)	0x0101	0x3112	R	BCD Format
768	Slot 19 Date (yyyy)	0x2014	0x2099	R	BCD Format
769	Slot 19 Time (hh:mm)	0x0000	0x2359	R	BCD Format
770	Slot 20 Type	0	3	R	0 = FST Close, 1 = FST Open, 2 = PST, 3 = Empty
771	Slot 20 Date (dd/mm)	0x0101	0x3112	R	BCD Format
772	Slot 20 Date (yyyy)	0x2014	0x2099	R	BCD Format
773	Slot 20 Time (hh:mm)	0x0000	0x2359	R	BCD Format

Address	Description	Min Value	Max Value	R/W	Notes
774	Reserved	0	65535	R	
775	Reserved	0	65535	R	
776	RTC Adjust			RW	See [3] for details.
777	Reserved	0	65535	R	
778	Reserved	0	65535	R	

5.5.1 Pressure 1-2 Registers

The value of these registers depends by the “Pressure Sensor 1-2” register value (holding register 133, see section 5.5.3 for details).

If “Pressure Sensor 1-2” is “10 bar”, “20 bar” or “50 bar”, the value of “Pressure 1-2 Registers” must be divided by 100.

Example: register value is 538, then pressure value is $538 / 100 = 5.38$ bar

If “Pressure Sensor 1-2” is “100 bar”, “200 bar” or “400 bar”, the value of “Pressure 1-2 Registers” must be divided by 10.

Example: register value is 538, then pressure value is $538 / 10 = 53.8$ bar

If “Pressure Sensor 1-2” is “145 psi”, “290 psi” or “725 psi”, the value of “Pressure 1-2 Registers” must be divided by 10.

Example: register value is 538, then pressure value is $538 / 10 = 53.8$ psi

If “Pressure Sensor 1-2” is “1450 psi”, “2900 psi” or “5800 psi”, the value of “Pressure 1-2 Registers” is the pressure value.

Example: register value is 538, then pressure value is 538 psi

5.5.2 Process Sensor Registers

The value of these registers depends by the “Process Sensor” register value (holding register 134, see section 5.5.3 for details).

If “Process Sensor” is “10 bar”, “20 bar” or “50 bar”, the value of “Process Sensor Registers” must be divided by 100.

Example: register value is 538, then pressure value is $538 / 100 = 5.38$ bar

If “Process Sensor” is “100 bar”, “200 bar” or “400 bar”, the value of “Process Sensor Registers” must be divided by 10.

Example: register value is 538, then pressure value is $538 / 10 = 53.8$ bar

If “Process Sensor” is “145 psi”, “290 psi” or “725 psi”, the value of “Process Sensor Registers” must be divided by 10.

Example: register value is 538, then pressure value is $538 / 10 = 53.8$ psi

If “Process Sensor” is “1450 psi”, “2900 psi” or “5800 psi”, the value of “Process Sensor Registers” is the pressure value.

Example: register value is 538, then pressure value is 538 psi

5.5.3 Pressure Sensor Registers

If “Pressure Measurement Unit” is “bar”, the values of these registers are:

Value	Description
0	None
1	10 bar
2	20 bar
3	50 bar
4	100 bar
5	200 bar
6	400 bar

If “Pressure Measurement Unit” is “psi”, the values of these registers are:

Value	Description
0	None
1	145 psi
2	290 psi
3	725 psi
4	1450 psi
5	2900 psi
6	5800 psi

5.5.4 Alarm Status 1

Bit	Description
0	PSCL Alarm
1	PSCT Alarm
2	PSSB Alarm
3	PSFB Alarm
4	PSST Alarm
5	PSFT Alarm
6	PSSP Alarm
7	PSSR Alarm
8	PSLB Alarm
9	PSHB Alarm
10	PSNM Alarm
11	PSA Alarm
12	PSB Alarm
13	SISA Alarm
14	SISB Alarm
15	OPOS Alarm

5.5.5 Alarm Status 2

Bit	Description
0	CPOS Alarm
1	LSP Alarm
2	HSP Alarm
3	LPP Alarm
4	HPP Alarm
5	OPNM Alarm
6	CLNM Alarm
7	OPCT Alarm
8	CLCT Alarm
9	FSCL Alarm
10	SOBT Alarm
11	FOBT Alarm
12	SOTT Alarm
13	FOTT Alarm
14	SCBT Alarm
15	FCBT Alarm

5.5.6 Alarm Status 3

Bit	Description
0	SCTT Alarm
1	FCTT Alarm
2	OHBP Alarm
3	OLBP Alarm
4	CHBP Alarm
5	CLBP Alarm
6	PS1 Alarm
7	PS2 Alarm
8	PPS Alarm
9	POS Alarm
10	BUS Alarm
11	MNT Alarm
12	CAL Alarm
13	Not Used
14	Not Used
15	Not Used

5.5.7 Alarm Log ID

Value	Description	Value	Description
0	None	24	OPNM
1	Reset	25	CLNM
2	Power On	26	OPCT
3	PSCL	27	CLCT
4	PSCT	28	FSCL
5	PSSB	29	SOBT
6	PSFB	30	FOBT
7	PSST	31	SOTT
8	PSFT	32	FOTT
9	PSSP	33	SCBT
10	PSSR	34	FCBT
11	PSLB	35	SCTT
12	PSHB	36	FCTT
13	PSNM	37	OHBP
14	PSA	38	OLBP
15	PSB	39	CHBP
16	SISA	40	CLBP
17	SISB	41	PS1
18	OPOS	42	PS2
19	CPOS	43	PPS
20	LSP	44	POS
21	HSP	45	BUS
22	LPP	46	MNT
23	HPP	47	CAL

6 Bus Menu

This section describes the IMVS2000v2 Modbus Bus Menu available by local operator interface and Biffi Assistant (see [1] for details).

Bus	..Exit Bus
	Bus Type
	Mod. Enabled
	Mod. Address
	Baud Rate
	Mod. Parity
	Term.

PARAMETER NAME	DESCRIPTION	RANGE	DEFAULT VALUE	R/W (1)	AVAILABLE ON (2) (3)
Bus Type	It indicates the bus type installed on IMVS2000v2.	-	Modbus	R	Local
Mod. Enabled (Modbus Enabled)	If it set "Yes" the Modbus RTU interface is enabled.	Yes, No	Yes	RW	Local, Serial, Bus
Mod. Address (Modbus Address)	It indicates the address used by IMVS2000v2 during Modbus communication.	1 – 247	1	RW	Local, Serial, Bus
Baud Rate	It indicates the baud rate used during Modbus communication. This setting becomes "active" by disabling and enabling the Modbus Interface (Mod. Enabled).	600 bps, 1200 bps, 2400 bps, 4800 bps, 9600 bps, 19200 bps, 38400 bps	19200 bps	RW	Local, Serial, Bus
Mod. Parity (Modbus Parity)	It indicates the parity used during Modbus communication. This setting becomes "active" by disabling and enabling the Modbus Interface (Mod. Enabled).	None, Odd, Even	Even	RW	Local, Serial, Bus
Term. (Termination)	It indicates the Modbus interface termination status.	Active, Not Active	Not Active	RW	Local, Serial, Bus



BIFFI ITALIA s.r.l.
Loc. Caselle S. Pietro
29017 Fiorenzuola d'Arda -Piacenza - ITALY -
Tel. (0523) 944411 - Fax (0523) 941885
E_mail: biffi_italia@biffi.it