

# Biffi PLA

## Double-Acting Pneumatic Linear Actuator



**Revision Details**

Rev.	Date	Description	Prepared	Checked	Approved
4	June 2020	General update (Migration to new template)			
3	May 2018	Updated Data-plate	Ermanni	Orefici	Vigliano
2	April 2016	Updated applicable regulation (Section 1.1.1)	Ermanni	Orefici	Vigliano
1	October 2009	General update	Ermanni	Orefici	Vigliano
0	May 1999	Document release	Lazzarini	Aliani	Ziveri

# Table of Contents

## Section 1: General Warnings

1.1	Generalities.....	1
1.1.1	Applicable Regulation.....	1
1.1.2	Terms and Conditions.....	2
1.2	Identification Plate.....	2
1.3	Introducing the Actuator.....	3
1.4	Data Sheet.....	4

## Section 2: Installation

2.1	Checks Upon Actuator Receipt.....	5
2.2	Actuator Handling.....	5
2.3	Storage.....	6
2.4	Actuator Assembly on the Valve.....	7
2.4.1	Types of Assembly.....	7
2.4.2	Assembly Procedure.....	7
2.5	Pneumatic Connections.....	12
2.6	Electrical Connections (If Any).....	12
2.7	Commissioning.....	13

## Section 3: Operation and Use

3.1	Operation Description.....	14
3.2	Residual Risks.....	15
3.3	Operations.....	15
3.3.1	Local Pneumatic Operation.....	15
3.3.2	Electric Remote Control to Open and to Close.....	16
3.3.3	Emergency Manual Operation by MSJ / MH.....	16
3.3.4	Emergency Manual Operation by MHP.....	17
3.4	Calibration of The Linear Stroke.....	17
3.5	Calibration of Micro-Switches (for Biffi limit switch box*).....	20
3.6	Calibration of the Operation Time.....	22

## Section 4: Operational Tests and Inspections

	Operational Tests and Inspections.....	24
--	--	----

## Section 5: Maintenance

5.1	Periodic Maintenance.....	25
5.1.1	Check and Restore Oil Level in the Gas-Hydraulic Tanks.....	26
5.1.2	Gas Supply Dehydrating Filter Maintenance (if foreseen).....	27
5.1.3	Lubrication of Actuator.....	28
5.2	Extraordinary Maintenance .....	29
5.2.1	Replacement of Cylinder Seals .....	29
5.3	Dismantling and Demolition .....	33

## Section 6: Troubleshooting

6.1	Failure or Breakdown Research.....	34
-----	------------------------------------	----

## Section 7: Layouts

7.1	Spare Parts Order .....	35
7.2	Parts List for Maintenance and Replacing Procedure .....	36

## Section 8: Date Report for Maintenance Operations

	Date Report for Maintenance Operations .....	45
--	--	----

## NOTICE

Biffi Italia s.r.l. pays the highest attention to collecting and verifying the documentation contained in this user manual. However Biffi Italia s.r.l. is not liable for any mistakes contained in this manual, for damage or accidents due to the use of the latter. The information contained is of exclusive reserved ownership of Biffi Italia s.r.l. and may be modified without prior notice. All rights reserved.

# Section 1: General Warnings

## NOTICE

The manual is an integral part of the machine, it should be carefully read before carrying out any operation and it should be kept for future references.

## 1.1 Generalities

Biffi Italia s.r.l. actuators are conceived, manufactured and controlled according to the Quality Control System in compliance with EN-ISO 9001 international regulation.

### 1.1.1 Applicable Regulation

EN ISO 12100:2010:	<b>Safety of machinery – General principles for design – Risk assessment and risk reduction</b>
2006/42/EC:	<b>Machine directive</b>
2014/68/EU:	<b>Directive for pressure PED equipment</b>
2014/35/EU:	<b>Directive for low voltage equipment</b>
2014/30/EU:	<b>Directive for the electromagnetic compatibility</b>
2014/34/EU:	<b>Directive and safety instructions for use in hazardous area</b>

## 1.1.2 Terms and Conditions

Biffi Italia s.r.l. guarantees that all the items produced are free of defects in workmanship and manufacturing materials and meet relevant current specifications, provided they are installed, used and serviced according to the instructions contained in the present manual. The warranty can last either one year from the date of installation by the initial user of the product, or eighteen months from the date of shipment to the initial user, depending on which event occurs first. All detailed warranty conditions are specified in the documentation forwarded together with the product. This warranty does not cover special products or components not warranted by subcontractors, or materials that were used or installed improperly or were modified or repaired by unauthorized staff. In the event that a fault condition be caused by improper installation, maintenance or use, or by irregular working conditions, the repairs will be charged according to applicable fees.

**The warranty and Biffi Italia s.r.l. liability shall lapse in the event that any modification or tampering whatsoever be performed on the actuator.**

## 1.2 Identification Plate

It is forbidden to modify the information and the marks without previous written authorization by Biffi Italia s.r.l.

The plate fastened on the actuator contains the following information (Figure 1).

**Figure 1 Data Plate**

		<b>CE</b>	
Order _____			
Model _____			
ACTUATOR	S/N	_____	MM/YYYY
	TAG N°	_____	ND
Supply Press.Range		_____	MOP
Amb.Temp. _____			
CYLINDER	Fl.Type	_____	Fl.Group PED Cat. _____
	TS	_____	Test Date _____
	PS	_____	PT _____ Cyl.Weight _____
		Ref.: _____	WARNING: Potential Electrostatic Charging Hazard See Instructions

## 1.3 Introducing the Actuator

PLA Double-Acting Pneumatic Low-Pressure Linear Actuators, are suitable for the operation of linear valves (wedge gate valves, through conduit gate valves) for ON-OFF and modulating heavy-duty service.

The actuator is made up of a pneumatic cylinder and a mounting pedestal complete with a joint for the coupling to the valve stem of actuator output stem. The valve is actuated in opening and in closing position by the actuator pneumatic cylinder that is pressurized in one or in the other direction.

The linear stroke of the valve is adjustable by means of the external mechanical stop for upward position and by the adjustment of the coupling of valve stem to actuator joint for the downward position.

The actuator pedestal has a flange with threaded holes to fix the actuator to the valve.

Biffi can supply different types of control system following Customer's requirements.

The expected lifetime of actuator is approximately 25 years .

**Figure 2 Identification of actuator parts**

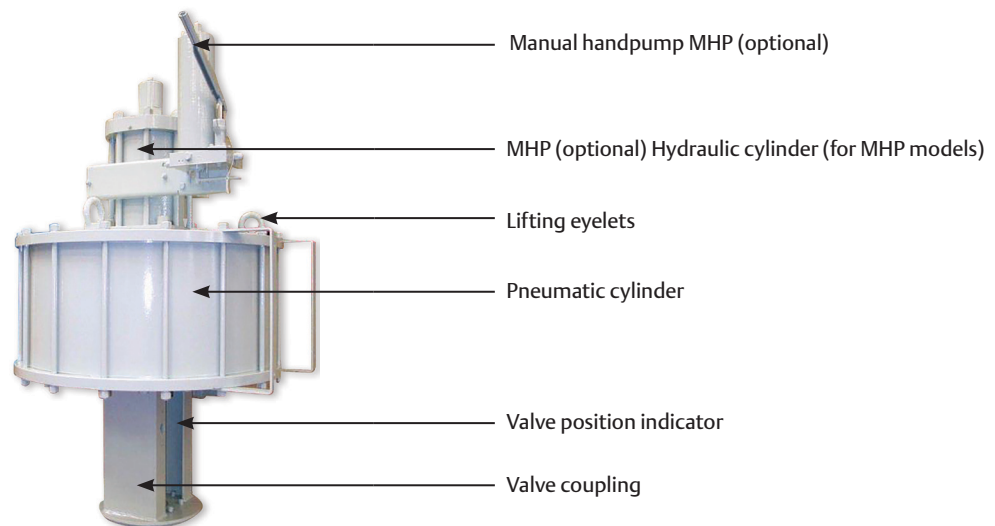

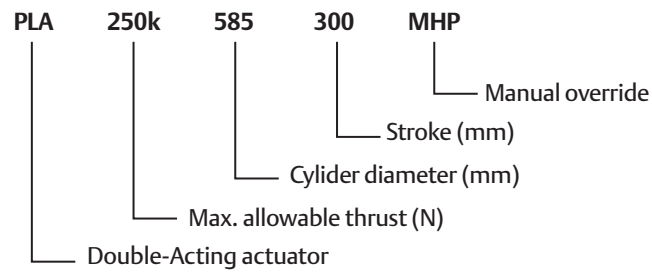

## 1.4 Data sheet

Supply fluid	Air, Nitrogen or sweet gas
Operating temperature	Standard: from $-30\text{ }^{\circ}\text{C}$ to $+100\text{ }^{\circ}\text{C}$ Optional: from $-60\text{ }^{\circ}\text{C}$ to $+140\text{ }^{\circ}\text{C}$
Supply pressure	10.5 bar max.

## Section 2: Installation

### 2.1 Checks Upon Actuator Receipt

- Check that the model, the serial number of the actuator and the technical data reported on the identification plate correspond with those of order confirmation, see Section 1.2.
- Check that the actuator is equipped with the fittings as provided for by order confirmation.
- Check that the actuator was not damaged during transportation: if necessary renovate the painting according to the specification reported on the order confirmation.
- If the actuator is received already assembled with the valve, its settings have already been made at the factory.
- If the actuator is delivered separately from the valve, it is necessary to check, and if required, to adjust, the settings of the mechanical stops, (refer to Section 3.4) and of micro-switches (if any) refer to Section 3.5.

### 2.2 Actuator Handling

#### NOTICE

The lifting and handling should be made by qualified staff and in compliance with the laws and provisions in force.

#### ⚠ WARNING

The fastening points are appropriate for the lifting of the actuator alone and not for the valve + actuator assembly. Avoid that during the handling, the actuator passes above the staff. The actuator should be handled with appropriate lifting means. The weight of the actuator is reported on the delivery bill.

For a correct lifting procedure, please refer to following Figures.

**Figure 3** Lifting Points for PLA Actuators

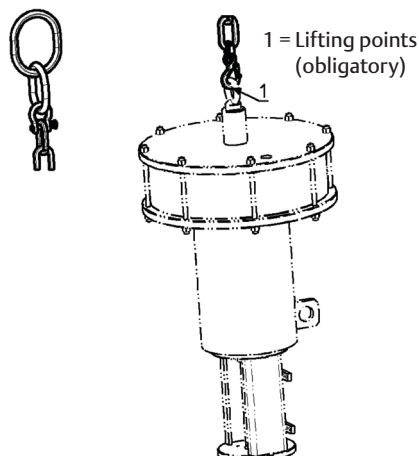

---

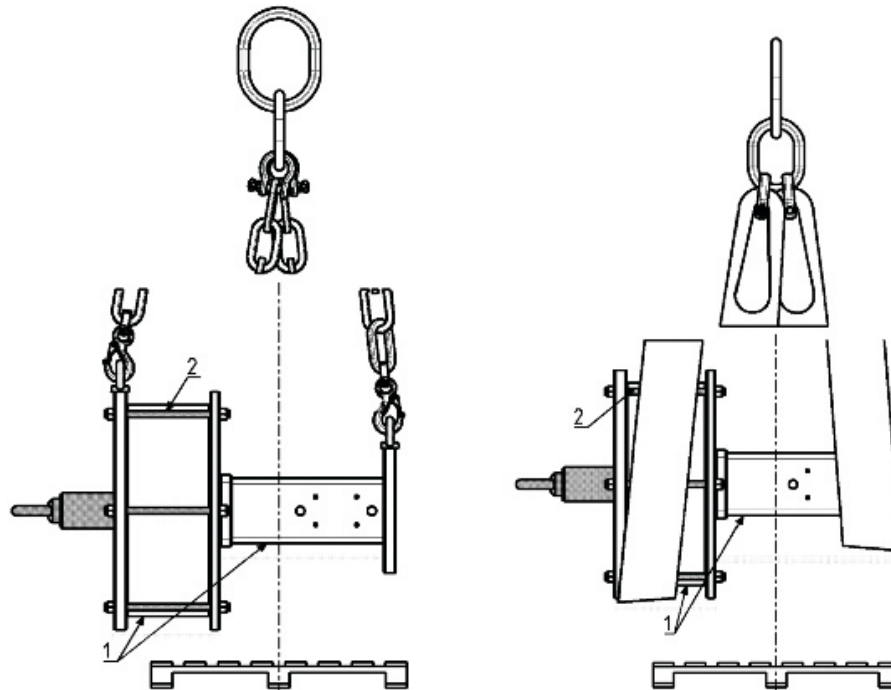
**Figure 4 Positioning by chains and by slings**

- 
1. Point of support
  2. Don't lay the actuator on tie-rods of cylinder
  3. Don't lay the actuator on accessories  
(manual handpump, manual jackscrew, pneumatic control group etc.)

## 2.3 Storage

If the actuator needs storage, before installation follow these steps:

- Place it on a wood surface in order not to deteriorate the area of valve coupling.
- Make sure that plastic plugs are present on the hydraulic and electrical connections (if present).
- Check that the protection of the control system and of the limit switch box (if any) are properly closed.

If the storage is long-term or outdoor:

- Keep the actuator protected from direct weather conditions.
- Replace plastic plugs of hydraulic and electrical connections (if any) with metal plugs that guarantee perfect tightness.
- Coat with oil, grease or protection disc, the valve coupling area.
- Periodically operate the actuator, refer to Section 3.3.

## 2.4 Actuator Assembly on the Valve

### 2.4.1 Types of Assembly

The adapter pedestal in fabricated carbon steel is specifically designed for adaptation to any type of valve with provision for local indicator, limit switches and other accessories (on request).

Lift the actuator by safety-hook for chains using the lifting-points (see Section 2.2) on the top of actuator for handling, transporting and assembling in vertical position (see Figure 3). For handling, transporting and assembling the actuator in horizontal position by safety-hook for chains use the lifting-points on the top of cylinder head-flange and on coupling flange (see Figure 4).

### 2.4.2 Assembly Procedure

#### **WARNING**

Failure to comply with the following procedures may impair product warranty. Installation, commissioning and maintenance and repair works should be carried out by qualified staff. A non-conforming assembly could be the source of serious accidents.

For actuator assembly on the valve:

#### **NOTICE**

Check that the assembly position, as shown on the documentation, complies with system's geometry. Check the consistency of the parts of actuator-valve coupling.

- A. To assemble the actuator onto the valve by bracket with threaded joint proceed as follows:

**Figure 5 Pedestal with threaded coupling joint**

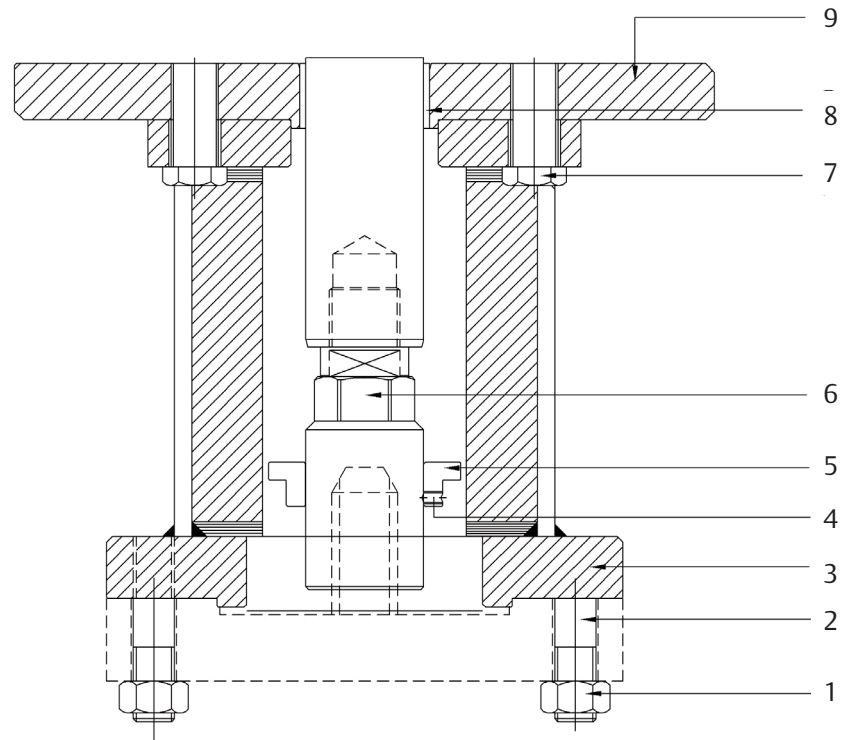

**Table 1. Parts list**

Item	Description
1	Nut
2	Stud bolt
3	Support joint
4	Index
5	Screw
6	Connecting joint
7	Screw
8	Bushing
9	Flange

1. Check that the coupling dimensions of the valve flange and stem, or of the relevant extension, meet the actuator coupling dimensions (valve stem and flange). Lubricate the valve stem with grease in order to make the assembly easier.
2. Connect a sling to the support point of the actuator and lift it. To make easier the assembly, the valve stem has to be in perfect vertical position.

## NOTICE

The eyebolt is sized for the lifting of the only actuator (NOT ACTUATOR+VALVE). Proper lifting points have to be foreseen for the valve.

3. Screw the actuator coupling joint onto the valve by rotating the actuator, or screw down the valve stem stroke-ring with Red Loctite 542 and fix the half bearings. When the threaded holes of the actuator flange are in correspondence with the holes on the valve flange screw the proper stud bolts. Screw the nuts on the stud bolts and tighten up the valve flange is in contact with the actuator flange.
4. Tighten the nuts of the connecting stud bolts evenly with the torque prescribed in the table. The stud bolts must be made of ASTM A320 L7 steel, the nuts must be made of ASTM A194 grade 2 steel as minimum.

- B. To assemble the actuator onto the valve by bracket with shell joint, perform the following operations:

**Figure 6 Pedestal with shell coupling joint**

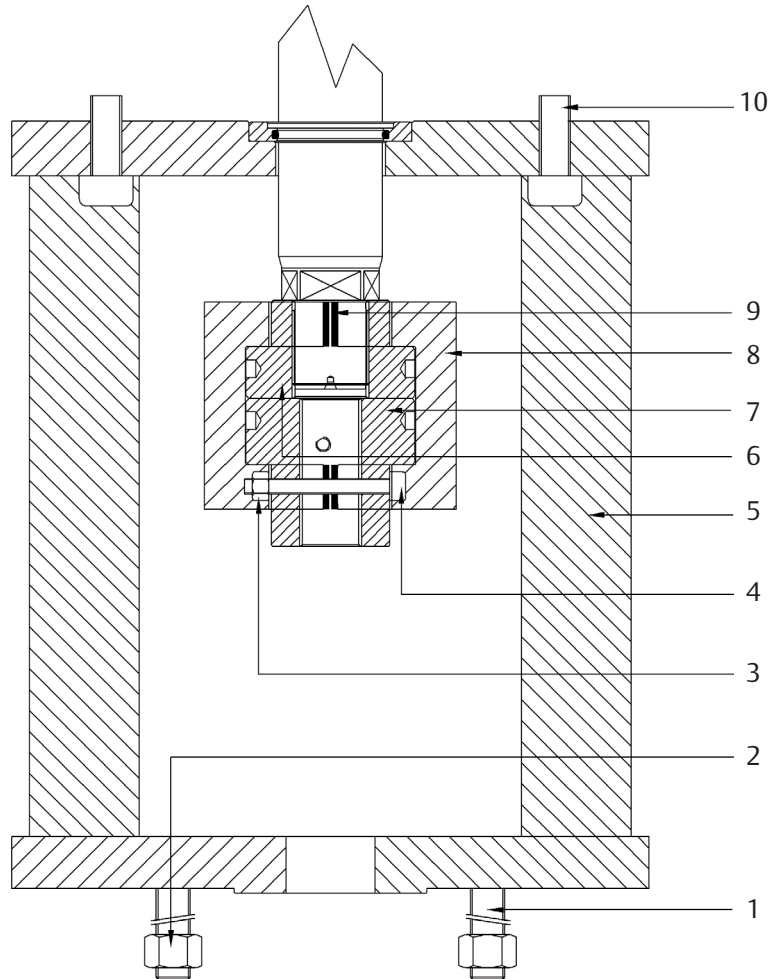

**Table 2. Parts list**

Item	Description
1	Stud bolt
2	Nut
3	Nut
4	Screw
5	Pedestal
6	Actuator joint
7	Stem valve joint
8	Shell joint
9	Spacer
10	Screw

1. Check that the coupling dimensions of the valve flange and stem, or of the relevant extension, meet the actuator coupling dimensions (valve stem and flange). Lubricate the valve stem with grease in order to make the assembly easier.
2. To make easier the assembly, the valve stem has to be in perfect vertical position.
3. Disassemble the two halves of actuator pedestal shell joint (item 8) by unscrewing the retaining screws (item 4), therefore disassemble the valve stem joint (item 7).
4. Lift the actuator by utilizing the proper lifting eyelets, and unscrew the nuts and the stud bolts from the actuator pedestal.
5. Assemble the actuator onto the valve, and arrange it in its correct vertical position proper to connection between valve stem and actuator cylinder rod.
6. Screw the valve stem joint (item 7) on valve stem up to reach the proper position which allow the reassembly of the two halves of shell joint (item 8), tighten the joint fastening screws (item 4).
7. Screw the stud bolts (item 1) into the actuator pedestal flange, and screw the nuts on the stud bolts.
8. Tighten according to the nut (item 2) size torque requirements.

To operate refer to following Table:

**Table 3. Nuts Tightening Torque**

Threading	Tightening torque (Nm)
M8	20
M10	40
M12	70
M14	110
M16	160
M20	320
M22	420
M24	550
M27	800
M30	1100
M33	1400
M36	1700

The screwing values in Table 3 were calculated considering the materials ASTM A320 L7 for screws or tie rods and ASTM A194 gr.2H for the nuts.

## 2.5 Pneumatic Connections

### WARNING

Check that the values of pneumatic supply available are compatible with those reported on the identification plate of the actuator.

### NOTICE

The connections should be made by qualified staff. Use pipes and connections appropriate as for type, material and dimensions.

- Properly deburr the ends of rigid pipes.
- Properly clean the interior of pipes sending through them plenty of the supply fluid used in the system.
- Mould and fasten the connection pipes so that no irregular strains at entries or loosening of threaded connections occur.
- Make the connections according to the operating diagram.
- Check the absence of leakages from pneumatic connections.

## 2.6 Electrical Connections (If Any)

### WARNING

Use components appropriate as for type, material and dimensions. The connections should be made by qualified staff. Before carrying out any operation, cut line power off.

#### Safety provisions:

2006/95/EC: Directive for low voltage equipment (until 19 April 2016)  
2014/35/EU from 20 April 2016

2004/108/EC: Directive for the electromagnetic compatibility (until 19 April 2016)  
2014/30/EU from 20 April 2016

94/9/CE: Directive and safety instructions for use in hazardous Area (until 19 April 2016)  
2014/34/EU from 20 April 2016.

Remove plastic plugs from cables entries

- Screw firmly the cable glands.
- Introduce connection cables.
- Make the connections in compliance with applicable wiring diagrams on the documentation supplied.
- Screw the cable gland.
- Replace the plastic plugs of unused entries with metal plugs.

## 2.7 Commissioning

### WARNING

Installation, commissioning and maintenance and repair works should be made by qualified staff.

Upon actuator commissioning please carry out the following checks:

- Check that paint hasn't been damaged during transport, if necessary repair the damages to paint coat.
- Check that the pressure and quality of the gas supply (filtering degree, dehydration) are as prescribed. Check that the feed voltage values of the electric components (solenoid valve coils, micro-switches, pressure switches, etc.) are compatible with those reported on the identification plate of the actuator (Figure 1) and to specific data-plate on electric components.
- Check that the setting of the components of the actuator control unit (pressure regulator, pressure switches, flow control valves, etc.) meet the plant requirements.
- Carry out all kinds of operations and check their proper execution (Section 3.3).
- Check the absence of leakages in the pneumatic connections.
- If necessary tighten the nuts of the pipe-fittings.
- Check proper operation of all the due signalling (valve position, gas supply pressure etc.).
- Make a complete functional test in order to verify all the operations are executed according to operating schematic diagram supplied.

## Section 3: Operation and Use

### 3.1 Operation Description

The supply gas pressurizes the pneumatic-cylinder chamber relevant to the operation to carry out (opening or closing) (see following pages). This pressure starts the linear motion of the piston and the consequent motion of the valve stem that is coupled.

Figure 7

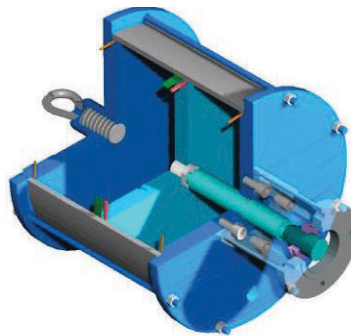

For local or remote operations, please refer to technical documentation furnished with actuators.

The power and control systems are supplied on specific customer demand.

#### NOTICE

For all the relevant information please refer to the specific documentation supplied.

Figure 8 **Double-Acting function with jackscrew manual override type MHW (direct action) or MSJ (that it can be engaged/disengaged by hand-lever)**

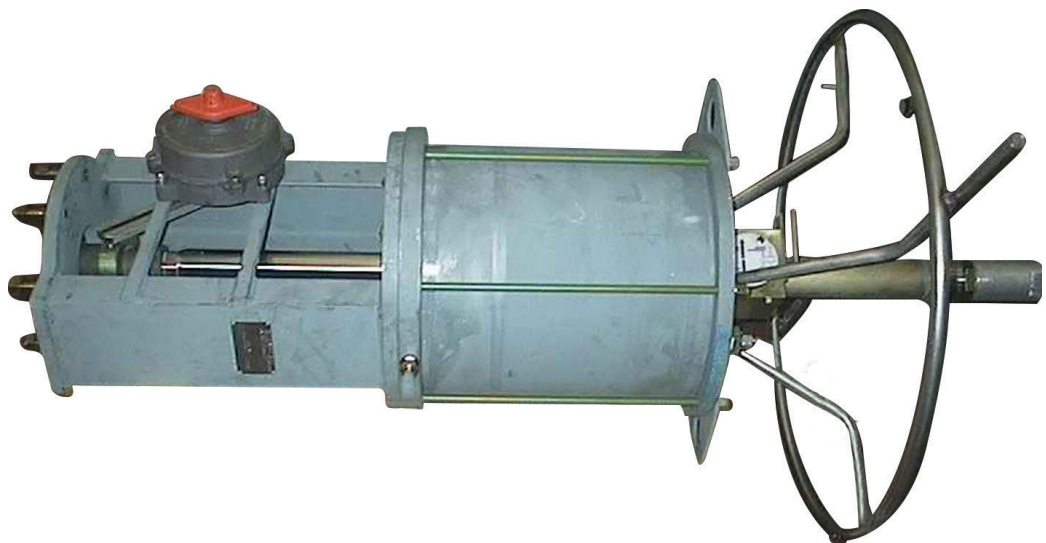

Figure 9 Double-Acting function with jackscrew manual override type MHP



## 3.2 Residual Risks

### **⚠ WARNING**

It is recommended to pipe exhaust gas.  
The actuator has parts under pressure.  
Use the due caution.  
Use individual protections provided for by the laws and provisions in force.

## 3.3 Operations

### 3.3.1 Local Pneumatic Operation

### **⚠ WARNING**

Use the proper safety measures to protect from any pressurized gas not piped and from excessive and harmful noise. Refer to applicable control schematic in supplied documentation.

---

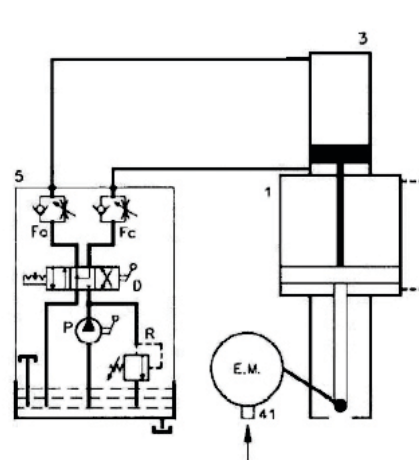
**Figure 10** PLAS MHP without control system



---

Pressurize the pneumatic-cylinder chamber, this pressure starts the linear motion of the piston and the consequent motion of the valve stem that is coupled.

The valve is actuated in opening and in closing position by the actuator pneumatic cylinder in one direction and by the spring unit in the other direction. Check the correct operation of the actuator through the visual position indicator.

### 3.3.2 Electric Remote Control to Open and to Close

When actuator is furnished of control system (panel or cabinet) remote operations were possible:

- From the control room send the electric signal corresponding to the operation to carry out: energize solenoid valve during all the valve stroke.
- Solenoid valve must be de-energized at the end of actuator operation.

### 3.3.3 Emergency Manual Operation by MSJ / MHW

**(when sufficient line pressure is not available)**

- Engage the manual override by rotating it's handle.
- Turn by the lever the manual override clockwise to close, or counterclockwise to open.
- Check the correct operation of the actuator through the visual position indicator.
- If no other manual operation is carried out, disengaged the manual override to allow the operation with pneumatic supply.

(see Section 7.2, Table 14: sectional drawing for Manual Jackscrew MSJ.)

### 3.3.4 Emergency Manual Operation by MHP

(when sufficient line pressure is not available)

- Select by the valve 5-D the opening or closing operation.
- Actuated the pump 5-P until to reach the complete operation.
- Check the correct operation of the actuator through the visual position indicator.
- If no other manual operation is carried out, the valve 5-D must be in “remote control” position to allow the operation with gas supply.

(see Section 7.2, Table 11, 12 and 13: sectional drawing for hydraulic control unit MHP).

## 3.4 Calibration of the Linear Stroke

It is important that the mechanical stops of the actuator (and not those of the valve) stop the linear stroke at both extreme valve position (fully open and fully closed), except when this is required by the valve operation).

The setting of the open/closed valve position (upward position) is performed by adjusting the travel stop screw into the end flange of the pneumatic cylinder and by the adjustment of the coupling of valve stem to actuator joint for the downward position.

For the adjustment of the travel stop screws proceed as follows:

1. Unscrew the plug from the “adjusting screw cover”.
2. If the actuator angular stroke is stopped before reaching the upward position (fully open or closed), unscrew the adjusting screw by turning it anticlockwise with a proper wrench, until the valve reaches the right position. When unscrewing the adjustable screw, keep the “adjusting screw cover still with a wrench so it does not withdraw together with the screw.
3. If the actuator angular stroke is stopped beyond the upward position (fully open or closed valve), screw the stop screw by turning it clockwise until the valve reaches the right position.
4. Screw the plug into the “adjustable screw cover”.

**Figure 11 Mechanical stop**

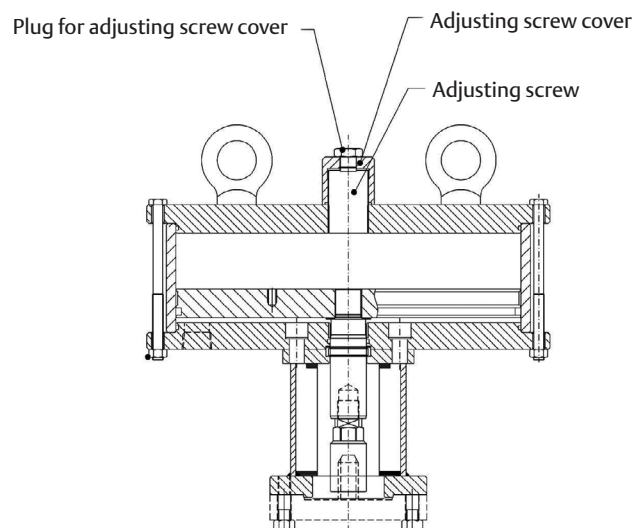

For the adjustment in PLA with hydraulic manual override the mechanical stop is placed on the end flange of hydraulic cylinder, follow these steps (Figure 12):

1. Remove with the specific wrench (c1) the plug (t).
2. Insert a wrench for Allen keys (c2) in the through hole until reaching the adjustment pin (g).
3. Keep the protection cover blocked with the special wrench (c3).
4. Turn counterclockwise to increase the angular stroke, turn clockwise to decrease it.
5. When the adjustment is over tighten the plug (t).

**Figure 12 Mechanical stop of the cylinder (for MHP version)**

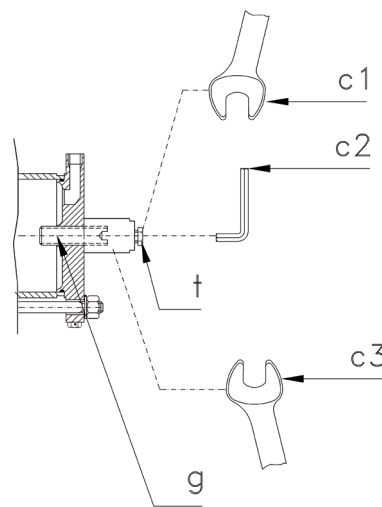

**Table 4. Size Table**

Hydraulic cylinder size	Wrench C1 (mm)	Wrench C2 (mm)	Wrench C3 (mm)
075	22	10	36
100	22	10	36
135	22	10	36
175	22	14	46
200	27	14	46
235	27	17	65
280	27	17	65
300	36	17	110

For the adjustment of the mechanical stop screwed on the end flange of manual override (see also Section 7.2, Table 14: sectional drawing for manual jackscrew MSJ) proceed as follows:

1. Loosen the lock nut (item 2).
2. If the actuator angular stroke is stopped before reaching the end position (fully open or closed), unscrew the stop screw (item 1) by turning it anticlockwise, and actuate the handwheel of manual override until the valve reaches the right position. When unscrewing the stop screw, keep the lock nut still with a wrench so that the sealing washer does not withdraw together with the screw.
3. Tighten the lock nut, after having correctly placed the threaded seal washer (item 3 and 4).
4. If the actuator angular stroke is stopped beyond the end position (fully open or closed valve), actuate the handwheel of manual override and screw the stop-screw by turning it clockwise until the valve reaches the right position.
5. Tighten the lock nut, after having correctly placed the threaded seal washer (item 3 and 4).

**Figure 13** Mechanical stop on the end flange of manual override

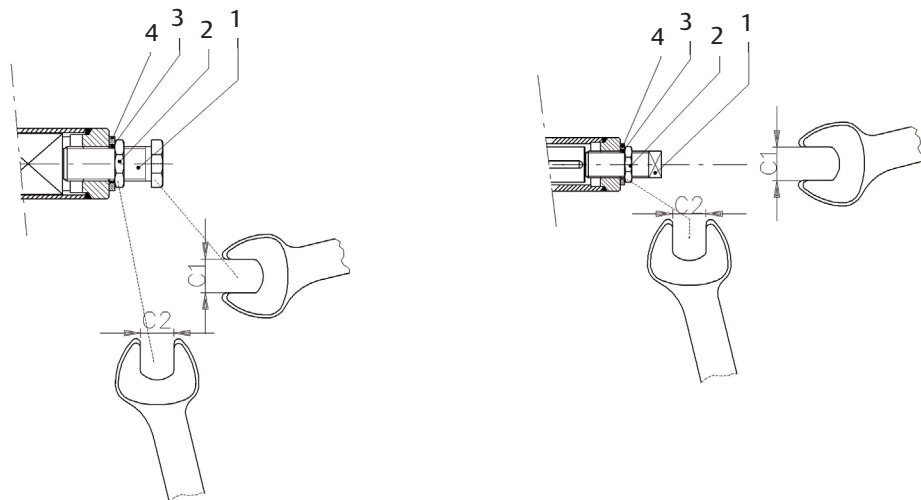

## 3.5 Calibration of Micro-Switches (for Biffi limit switch box \*)

### **⚠ WARNING**

\* If different micro-switches assembly or limit switch box is supplied, please refer to the specific documentation.

### **NOTICE**

Operate only the micro-switch corresponding to the direction of operation being carried out, as clearly reported on the micro-switch.

Micro-switches are placed inside a special box (Figure 14).

For micro-switches calibration please refer to the relative wiring diagram and follow these steps:

- Unscrew the fastening screws of the cover (Figure 14).
- Remove the cover paying attention not to deteriorate the gasket and the cylindrical and flat coupling surfaces.
- Operate the actuator (in opening or closing) with local pneumatic or hydraulic operation (Section 3.3).
- Unscrew the screw of the operating cam relative to the micro-switch to calibrate and adjust it according to the settings (Figure 15).
- Tighten the screw.
- Operate the actuator and adjust any other micro-switch with the procedure already described.
- Position the cover making sure the cam-carrier shaft grips with the index dragging shaft.
- Check that the cover and the index show the proper position of the valve (Figure 16).
- Tighten the screws.

**Figure 14** Micro-switches box

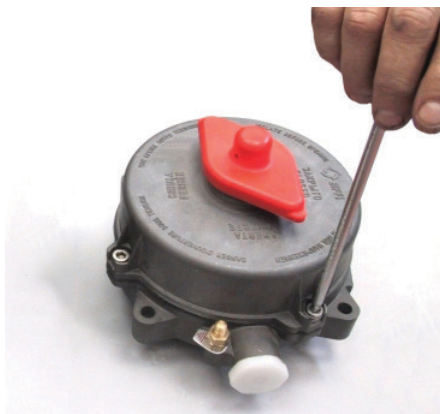

**Figure 15** Cam adjustment

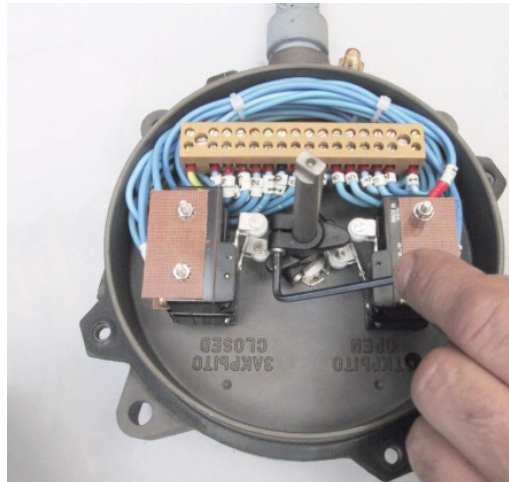

If the index (Figure 16), does not signal the proper position of the valve but is turned by 90°:

- Remove the roll pin placed on the position indicator (index).
- Turn the indicator until reaching its proper positioning.
- Put the roll pin back in its position.

**NOTICE**

End of stroke micro-switches should be operated before the stop of the stroke of the actuator due to mechanical stops. Adjust the relative cams properly.

**Figure 16** Position indicator and pin for micro-switches box

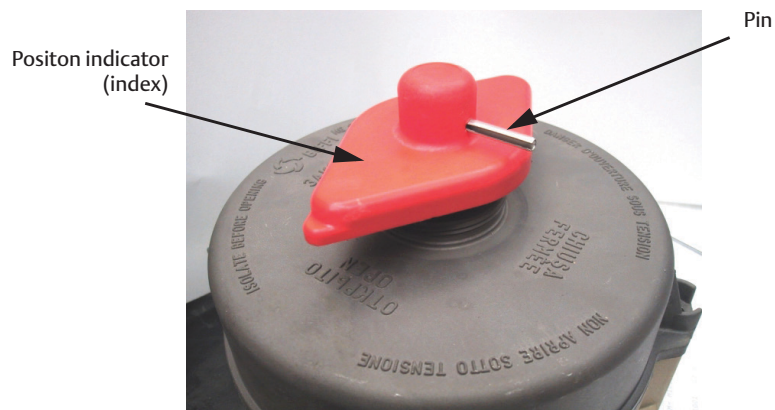

## 3.6 Calibration of the Operation Time

The calibration of the operation time is made by Biffi Italia s.r.l. according to customer requirements and to technical data-sheet included in technical documentation. If necessary it's possible to modify or reset the operating time through the flow regulation valve placed between the control valves enclosure and the pneumatic cylinder (Figure 17).

**Figure 17** Adjustment of Operation Time

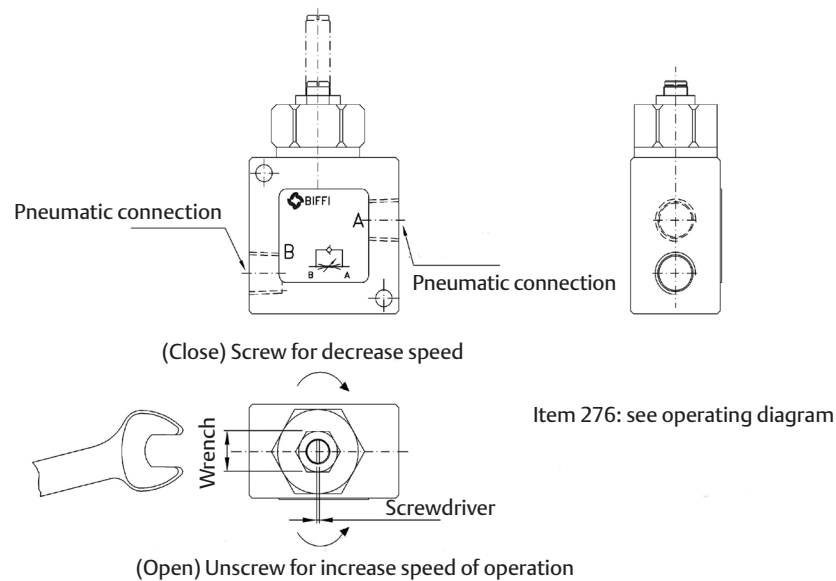

To carry out the adjustment, use an adequate Allen wrench and follow these steps (Figure 17):

- Loosen the lock nut.
- Screw with a screwdriver the setting screw to increase the operation time.
- Unscrew with a screwdriver the setting screw to decrease the operation time.
- After the adjustment is over screw the lock nut.

For PLA actuator models with Manual Handpump, the operating time is adjustable through two regulation valves placed on manual handpump body (see Section 7.2, Table 11, 12 and 13: sectional drawing for hydraulic control unit MHP).

To carry out the adjustment, use a suitable Allen wrench and follow these steps (Figure 18):

- Remove the cap nut.
- Loosen the lock nut.
- Screw with a screwdriver the setting screw to increase the operation time.
- Unscrew with a screwdriver the setting screw to decrease the operation time.
- After the adjustment is over screw the lock nut and put back in place the cap nut.

**Figure 18** Flow regulators placed on Manual Handpump

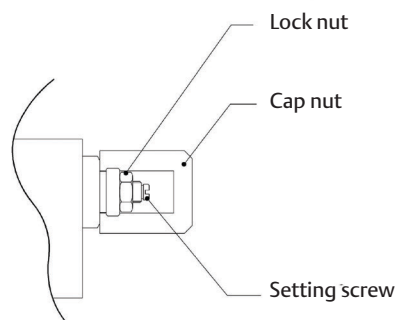

## Section 4: Operational Tests and Inspections

### **NOTICE**

To ensure the guaranteed SIL grade, according to IEC 61508, the functionality of actuator must be checked with regular intervals of time, as described in the Safety Manual.

---

## Section 5: Maintenance

### NOTICE

Before executing any maintenance operation, it is necessary to close the pneumatic supply line and discharge pressure from the cylinder of the actuator and from the control unit (if foreseen).

### ⚠ WARNING

Installation, commissioning and maintenance and repair works should be carried out by qualified staff.

## 5.1 Periodic Maintenance

PLA actuators are designed to operate long-term in heavy-duty operating conditions, without maintenance needs.

### NOTICE

Periodicity and regularity of inspections is particularly influenced by specific environmental and working conditions. They can be initially determined experimentally and then be improved according to actual maintenance conditions and needs.

Anyway every 2 years of operation the following is recommended:

- Check that the actuator operates the valve correctly and with the required operating times. If the actuator operation is very infrequent, carry out a few opening and closing operations with all the existing controls (remote control, local control, emergency controls, etc.), if this is allowed by the conditions of the plant.
- Check there are no hydraulic or pneumatic leakages.
- Check oil level (Figure 19) into the hydraulic manual handpump, if present (see Section 5.1.1).
- Check the actuators did not undergo accidental damage with oil leakages found on site (Section 5.1.1).
- Check that improper closing of control-group cover did not produce the presence of condensation on it.
- Check the integrity of worn out parts (gaskets, pads etc.).
- Replace, if any, the mechanical filter of the supply gas (refer to Section 5.1.2).

**Figure 19** Level measuring stick

### 5.1.1 Check and Restore Oil Level in the Hydraulic Manual Handpump

During the actuator operation, the oil tank has to be closed (not in connection with the atmosphere). Then avoid cavitation it is necessary to proceed as follows for the check of oil level into the tank:

1. Unscrew the dipstick (1).
2. Move the actuator into open position.
3. Check that the oil level into the tank (4) is in correspondence of the “MAX LEVEL” notch of the dipstick.
4. By leaving the dipstick unscrewed move the actuator, by the pneumatic control or by the handpump, to closed position.
5. Screw and tighten the dipstick.

If necessary substitute or added the oil, proceeding as follow:

- Remove the dipstick (1) from the tank cover (22).
- Unscrew the plug (27) and the washer (9) to drain all the oil.
- If some dirt or/and sludge is found in the oil drained from the tank, before filling with new oil in the tank, disassemble the oil tank tube, by unscrewing the two cap nuts (2), and clean the internal surfaces of the tank. If necessary substitute the gaskets (21) of the tank.
- Replace the plug (27) and the washer (9) into the plate (11) and tighten.
- Pour the new oil into the tank through the dipstick hole (1) on the cover (22).
- Replace the dipstick (1).
- Add oil (Table 5) if in the tank the level is BELOW MINIMUM (Figure 19).

**NOTICE**

For refill use oil of the same brand as the one in the tanks.

**Table 5. Features of hydraulic oil used by Biffi Italia s.r.l.**

Producer	AGIP
Name	ARNICA 22
Viscosity at 40 °C	22 cSt
Viscosity at 100 °C	5.2 cSt
Viscosity index ASTM	175
Flash point	192 °C
Pour point	-39 °C
Specific weight (at 15 °C)	0,857 kg/l
Equivalent oils:	SHELL TELLUS PLUS 22
	CHEVRON HYDRAULIC OIL AW ISO 22
	MOBIL DTE22
	EXXON UNIVIS N22
	EQUIVIS ZS22
	BP ENERGOL HLP-HM22
	CASTROL DYSPIIN AWS22

## 5.1.2 Gas Supply Dehydrating Filter Maintenance (if foreseen)

The gas supply filter is fitted with a mechanical filter and a drain valve to discharge periodically the water generated by the condensation of the humidity inside the gas supply.

During the routine maintenance it is recommended to check and clean the mechanical filter and replace it in case of heavy dirty conditions.

To disassemble the filter please consult technical documentation suitable for the component, in general:

- a. Close the stop valve at the inlet of pressure supply line;
- b. discharge the pressure from the drain valve;
- c. remove the lower enclosure screws,
- d. remove the mechanical filter;
- e. clean or replace the filter

Reinstall all parts carefully paying attention to avoid any damage to the seals.

### 5.1.3 Lubrication of Actuator

For normal duty the PLA actuator is lubricated "for life".

In case of high load and high frequency of operation it may be necessary to periodically restore lubrication: it is advisable to apply a generous coating of grease on the contact surfaces of moving parts.

The following grease is used by Biffi for standard working temperature and suggested for re-lubrication:

<b>Producer</b>	AGIP
<b>Name</b>	GR MU/EP2
<b>NLGI grade</b>	2
<b>Worked preparation (dmm)</b>	280
<b>Drop point ASTM (°C)</b>	185
<b>ISO grade</b>	X2
<b>Equivalent oils:</b>	ESSO BEACON EP2 BP GREASE LTX2 SHELL ALVANIA GREASE R2 ARAL ARALUB HL2 CHEVRON DURALITH GREASE EP2 CHEVRON SPHEEROL AP2 TEXACO MULTIFAK EP2 MOBILPLEX 47 PETROMIN GREASE EP2

For special working conditions and for working temperatures beyond the standard range consult Biffi.

## 5.2 Extraordinary Maintenance

If there are leaks in the hydraulic cylinder, pneumatic cylinder or a malfunction in the mechanical components, or in case of scheduled preventive maintenance, the actuator must be disassembled and seals must be replaced with reference to the follow general sectional drawing and adopting the following procedures.

### 5.2.1 Replacement of Cylinder Seals

(refer to Table 10)

#### NOTICE

Before executing any maintenance operation, it is necessary to intercept the supply line and discharge pressure from the cylinder of the actuator.

1. Unscrew the plug (30) from the adjusting screw cover (22).
2. Remove the adjusting screw cover (22) together with the O-ring (20).
3. Measure the distance of the protrusion of adjusting screw (21) with reference to the end flange (19) surface, so as to be able to easily restore the setting of the actuator mechanical stop, once the maintenance procedures have been completed.
4. Loosen the stop screw (21) until it is removed from the end flange (19).
5. Unscrew the nuts (28) from the tie rods (16) from the side of the end flange: they must be gradually unscrewed all at the same time.
6. Slide off the end flange (19) and the tube (14).

#### Seals replacement

Prior to reassemble check that the actuator components are in good conditions and clean. Lubricate all the surfaces of the parts, which move in contact with other components, by recommended grease (AGIP-ENI LCX 2/32 if seals are in NBR/Viton or Neoprene rubber, or with Aeroshell Grease 7 if the seals are in Fluorosilicon rubber). If the O-ring must be replaced, remove the existing one from its groove, clean the groove carefully and lubricate it with protective oil or grease film. Assemble the new O-ring into its groove and lubricate it with a protective oil or grease film.

1. Replace the O-ring (25) of the head flange (12).
2. Replace the O-ring (26) and the guide sliding ring (27) of the piston (18). Replace the O-ring (25) of the end flange (19).
3. Remove the O-ring (20) from the stop screw cover (22). Carefully clean and lubricate the stop screw thread and the surface of the end flange area, on which the sealing works.
4. Screw the new sealing onto the stop screw

### Reassemble

1. Carefully clean the inside of the tube (14) and check that the entire surface, particularly that of the bevels, is not damaged. Lubricate the inside surface of the tube and the bevels at the ends. Slide the tube onto the piston taking care not to damage the piston O-ring (26) and the head flange O-ring (12).
2. Assemble the end flange by centring it on the inside diameter of the tube, taking care not to damage the O-ring (25).
3. Assemble the the nuts (28) onto the tie rods (16). Tighten the nuts to the recommended torque, alternating between opposite corners.
4. Screw the stop screw (21) into the threaded hole of the end flange until it reaches its original position (the same protrusion with reference to the flange surface). To make the operation easier feed the pneumatic cylinder with air (if possible) in order to move the piston.
5. Tighten the adj. screw cover (22) and the nut (30).

### NOTICE

Carry out a few operations (Section 3.3) to check there are no leakages from the gaskets.

**Figure 20** PLA with Threaded Coupling Joint

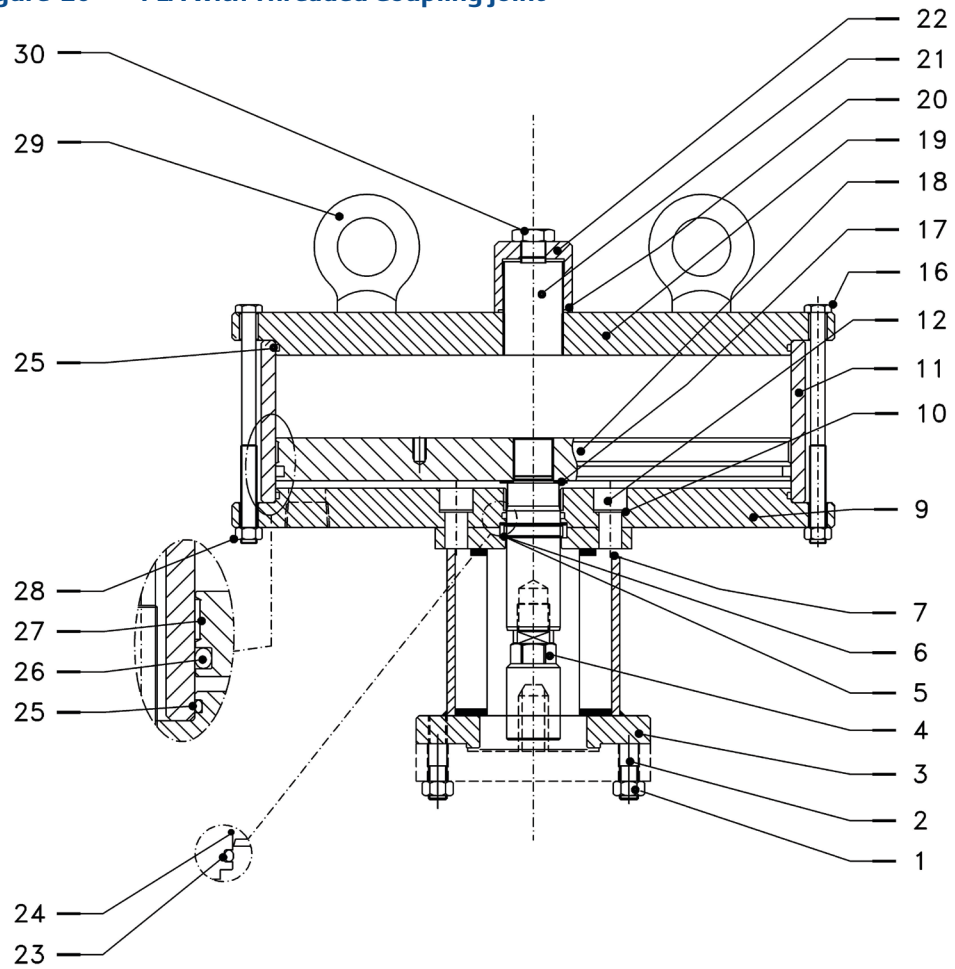

**Table 6.** Parts List

Item	Description	Item	Description
1	Nut	18	Piston
2	Stud bolt	19	End flange
3	Support joint	20	O-ring
4	Connecting joint	21	Adjusting screw
5	Scraper support	22	Adjusting screw cover
6	Scraper ring	23	O-ring
7	Screw	24	Bushing
9	Head flange	25	O-ring
10	Seal washer	26	O-ring
11	Cylinder tube	27	Guide sliding piston ring
12	Screw	28	Nut
16	Tie rod	29	Eyebolt
17	Sealing washer	30	Plug for adj. screw cover

Figure 21 PLA with Shell Coupling Joint

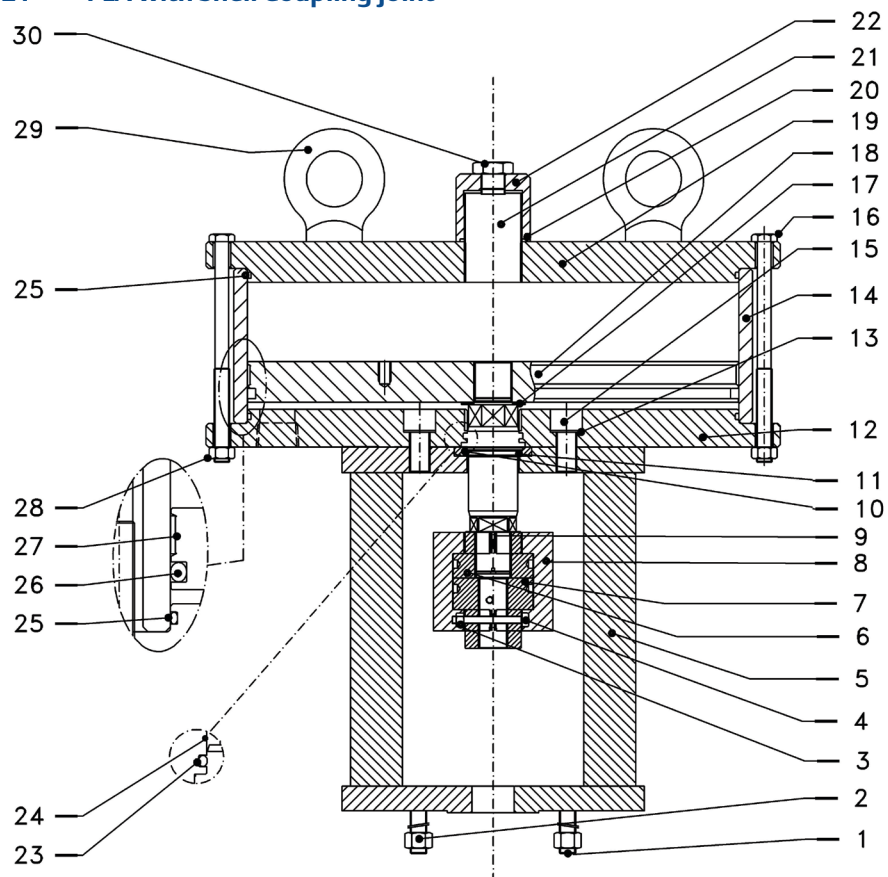

Table 7. Parts List

Item	Description	Item	Description
1	Stud bolt	16	Screw
2	Nut	17	Connecting device
3	Nut	18	Piston
4	Screw	19	End flange
5	Pedestal	20	O-ring
6	Actuator joint	21	Adjusting screw
7	Stem valve joint	22	Adjusting screw cover
8	Shell joint	23	O-ring
9	Spacer	24	Bushing
10	Scraper support	25	O-ring
11	Scraper ring	26	O-ring
12	Head flange	27	Guide sliding piston ring
13	Seal washer	28	Nut
14	Cylinder tube	29	Eyebolt and lifting eyelet
15	Screw	30	Plug for adj. screw cover

## 5.3 Dismantling and Demolition

### **WARNING**

Before disassembling the actuator it is necessary to close the pneumatic supply line and discharge pressure from the cylinder of the actuator, from the control unit and from the accumulator tank, if present. The demolition of the actuator both concerning any electrical and mechanical parts should be made by specialized staff.

Before starting the disassembly a large area should be created around the actuator so to allow any kind of movement without problems of further risks created by worksite.

Separate the parts composing the actuator according to their nature (ex. metallic, and plastic materials, fluids etc.) and send them to differentiated waste collection sites, as provided for by the laws and provisions in force.

# Section 6: Troubleshooting

## 6.1 Failure or Breakdown Research

**Table 8. Troubleshooting**

Event	Possible cause	Remedy
Actuator does not work	Lack of power supply	Restore it
	Lack of pneumatic supply	Open line interception valve
	Blocked valve	Repair or replace
	Wrong position of the distributor of the hydraulic manual override	Restore correct position
	Failure of the control system	Call Biffi Italia s.r.l. Customer Service
Actuator too slow	Low supply pressure	Restore (Section 1.4)
	Wrong calibration of flow regulator valves	Restore (Section 3.6)
	Wear of the valve	Replace
Actuator too fast	High supply pressure	Restore (Section 1.4)
	Wrong calibration of flow regulator valves	Restore (Section 3.6)
Leakages on hydraulic or pneumatic circuits	Deterioration and/or damage to gaskets	Call Biffi Italia s.r.l. Customer Service
Incorrect position of the valve	Wrong adjustment of mechanical stops	Restore (Section 3.4)
	Wrong warning of micro-switches	Restore (Section 3.5)
Hydraulic manual pump does not work	Handle positioned on remote control	Position the handle on the indication of the operation to make
	Leakages on the check valve of the hydraulic control group	Call Biffi Italia s.r.l. Customer Service

# Section 7: Layouts

## 7.1 Spare Parts Order

For spare parts order to the relevant Biffi office please make reference to Biffi order confirmation concerning all the supply, and serial number of the actuator, refer to Section 1.2 for any specific spare part for a specific actuator model.

**Please send every spare parts request to:**

Biffi Italia s.r.l. - Servizio Assistenza Tecnica Clienti

Tel.: 0523-944523

Fax: 0523-941885

e-mail: [Biffispares@Emerson.com](mailto:Biffispares@Emerson.com)

**Please specify:**

1. actuator model
2. Biffi acknowledgement
3. spare parts code
4. quantity
5. transport condition
6. involved people

## 7.2 Parts List for Maintenance and Replacing Procedure

Figure 22 Pedestal with coupling joint

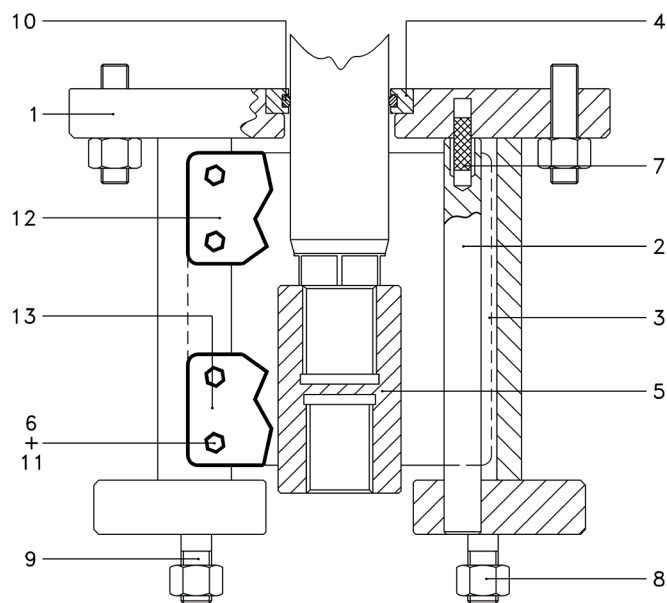

Table 9. Parts list - Pedestal with coupling joint

Item	Qty	Description	Material
1	1	Pedestal	Carbon steel
2	1	Antirotation shaft	Stainless steel
3	1	Plate	Stainless steel
4	1	Scrape ring flange	Stainless steel
5	1	Shell joint	Stainless steel
6	22	Screw	Stainless steel
7	1	Dowel	Stainless steel
8	4	Nut	Stainless steel
9	4	Stud bolt	Stainless steel
10	1	Scraper ring	Turcon+NBR*
11	22	Washer	Stainless steel
12	1	Plate	Stainless steel
13	1	Plate	Stainless steel

**NOTE:**

\* Recommended spare parts

**Figure 23 Pneumatic cylinder**

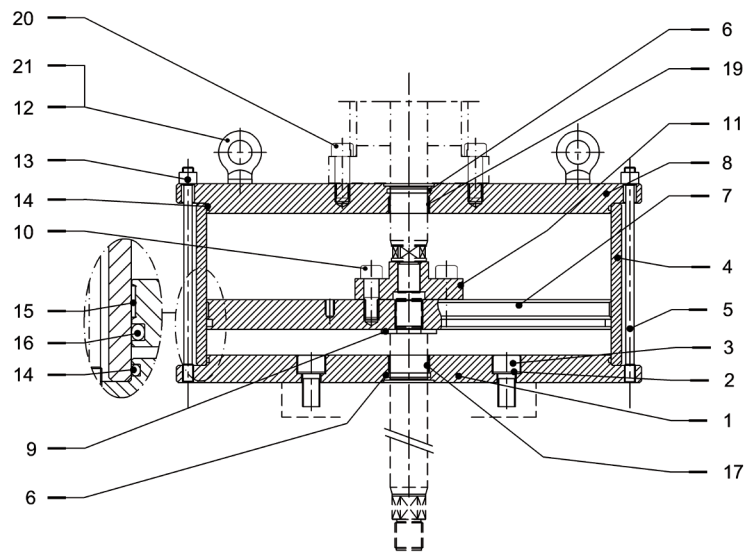
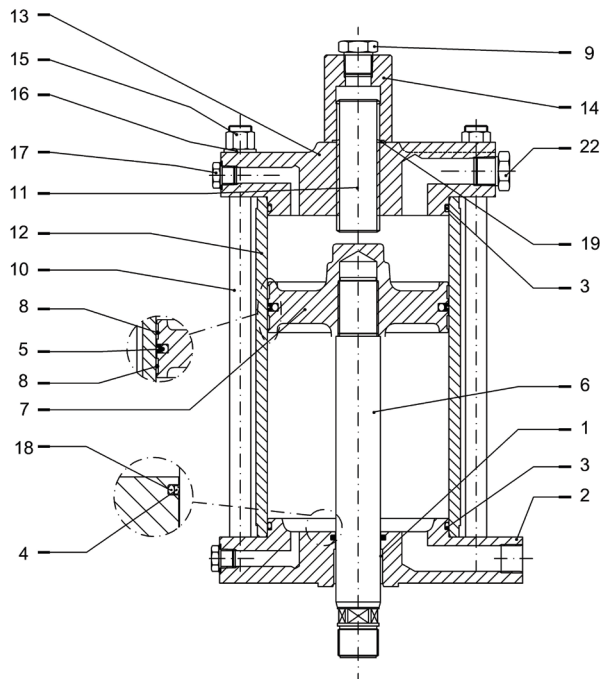

**Table 10. Parts list - Pneumatic Cylinder**

Item	Qty	Description	Material
1	1	Head flange	Carbon steel
2	8	Washer	Carbon steel+nitrile rubber
3	12	Screw	Alloy steel
4	1	Cylinder tube	Carbon steel
5	8	Tie rod	Alloy steel
6	2	O-ring	Viton rubber*
7	1	Piston	Carbon steel
8	1	End flange	Carbon steel
9	1	Washer	Alloy steel
10	4	Screw	Alloy steel
11	1	Joint	Carbon steel
12	4	Eyebolt	Carbon steel
13	8	Nut	Carbon steel
14	2	O-ring	Viton rubber*
15	1	Guide sliding ring for piston	Teflon+Graphite*
16	1	O-ring	Viton rubber*
17	1	Rod bushing	Steel+bz+Teflon
19	1	Rod bushing	Steel+bz+Teflon
20	4	Screw	Alloy steel
21	4	Washer	Carbon steel

**NOTE:**

\* Recommended spare parts

**Figure 24 Hydraulic Cylinder for Manual Handpump****Table 11. Parts list - Hydraulic cylinder for manual handpump**

Item	Qty	Description	Material
1	1	Piston rod bushing	Steel+bz+Teflon
2	1	Head flange	Carbon steel
3	2	O-ring	NBR *
4	1	Piston rod seal ring	Teflon + graphite*
5	1	Piston seal ring	Teflon + graphite + NBR*
6	1	Piston rod	Alloy steel
7	1	Piston	Nickel plated carbon steel
8	2	Guide sliding ring for piston	Teflon + graphite*
9	1	Plug	Carbon steel
10	4	Tie rod	Alloy steel
11	1	Stop setting screw	Alloy steel
12	1	Cylinder tube	Nickel plated carbon steel
13	1	End flange	Carbon steel
14	1	Stop setting screw cover	Carbon steel
15	4	Nut	Stainless steel
16	4	Spring washer	Carbon steel
17	6	Plug	Stainless steel
18	1	O-ring	NBR *
19	1	O-ring	NBR *

**NOTE:**

\* Recommended spare parts

**Figure 25 Hydraulic control unit**

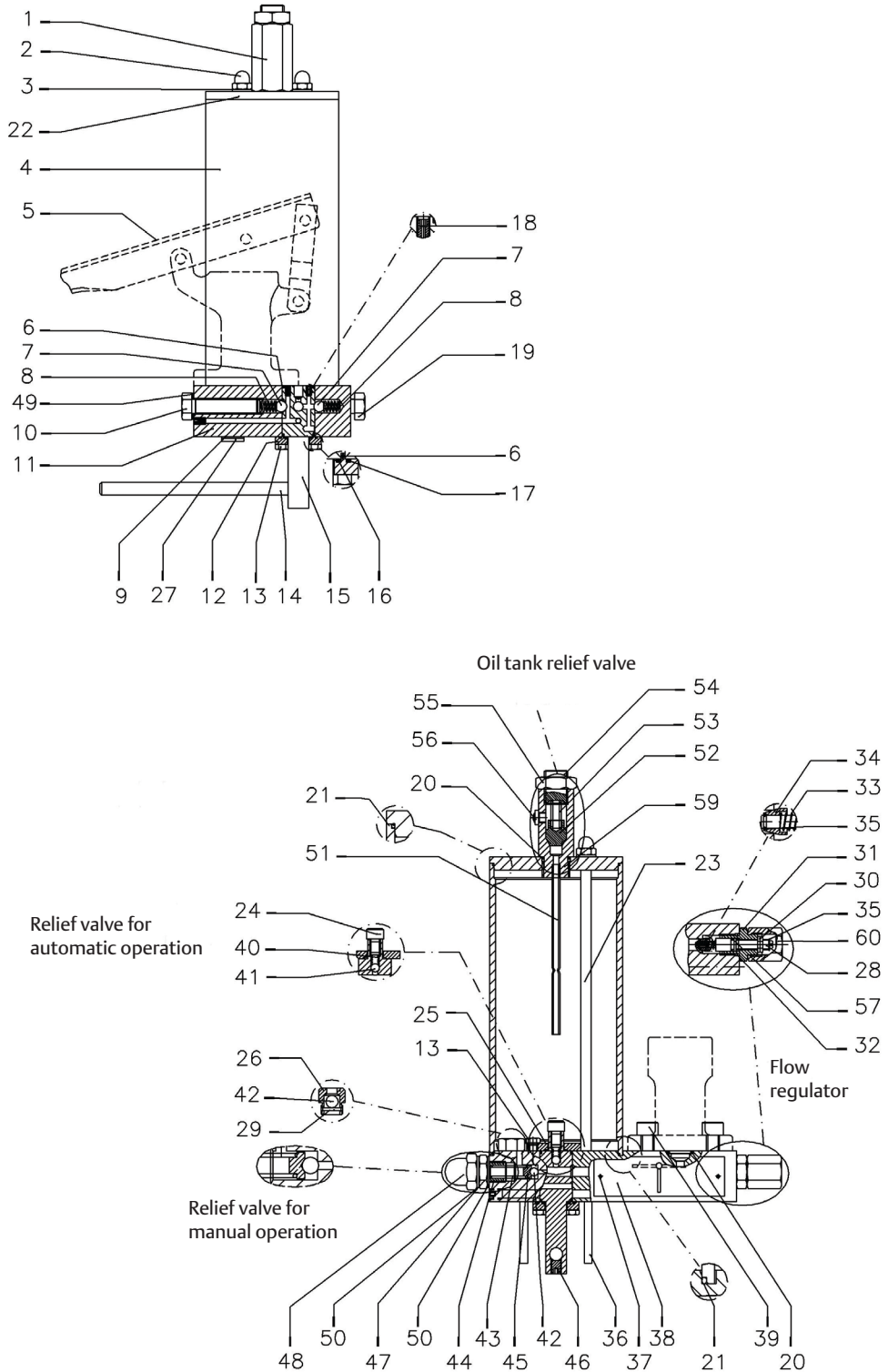

**Table 12. Parts list - 5/B hydraulic control unit**

Item	Qty	Description	Material
1	1	Dipstick	-
2	2	Cap nut	Carbon steel
3	2	Washer	Carbon steel + rubber
4	1	Hydraulic tank	Carbon steel
5	1	Handpump	See attached table
6	2	O-ring	Fluorosilicon rubber*
7	2	Ball	Stainless steel
8	2	Spring	Spring steel
9	1	Washer	Carbon steel + rubber
10	1	Screw	Carbon steel
11	1	Plate	Carbon steel
12	1	Flange	Aluminium
13	4	Screw	Carbon steel
14	1	Lever	Carbon steel
15	1	Distributor	Stainless steel
16	1	O-ring	Fluorosilicon rubber*
17	1	O-ring	Fluorosilicon rubber*
18	1	Nozzle	Carbon steel
19	2	Screw	Carbon steel
20	3	O-ring	Fluorosilicon rubber*
21	2	O-ring	Fluorosilicon rubber*
22	1	Tank cover	Carbon steel
23	2	Tie rod	Carbon steel
24	1	Screw	Carbon steel
25	1	Flange	Aluminium
26	2	Check valve body	Aluminium
27	1	Plug	Carbon steel
28	2	Flow control valve setting screw	Stainless steel
29	2	Spring pin	Stainless steel
30	2	Nut	Carbon steel

Item	Qty	Description	Material
31	2	Flange	Carbon steel
32	2	O-ring	Fluorosilicon rubber*
33	2	Spring	Spring steel
34	2	Plug	Stainless steel
35	2	Retainer ring	Carbon steel
36	2	Spring pin	Carbon steel
37	2	Rivet	Aluminium
38	1	Operation instruction plate	Stainless steel
39	4	Screw	Carbon steel
40	1	Spring	Stainless steel
41	1	Ball	Stainless steel
42	3	Ball	Stainless steel
43	1	Spring	Carbon steel
44	1	Relief valve setting screw	Alloy steel
45	1	Spring pin	Carbon steel
46	1	Screw	Alloy steel
47	1	Spring	Stainless steel
48	1	Nut	Carbon steel
49	1	Washer	Carbon steel + rubber
50	2	Washer	Carbon steel + rubber
51	1	Dipstick	Stainless steel
52	1	Plug + O-ring	Stainless steel + fluorosilicon rubber*
53	1	Spring	Stainless steel
54	1	Screw	Alloy steel
55	1	Nut	Carbon steel
56	1	Silencer	Brass
57	1	O-ring	Fluorosilicon rubber*
58	1	Retainer ring	Spring steel
59	1	Dipstick body	Aluminium
60	2	Nut	Carbon steel

**NOTE:**

\* Recommended spare parts

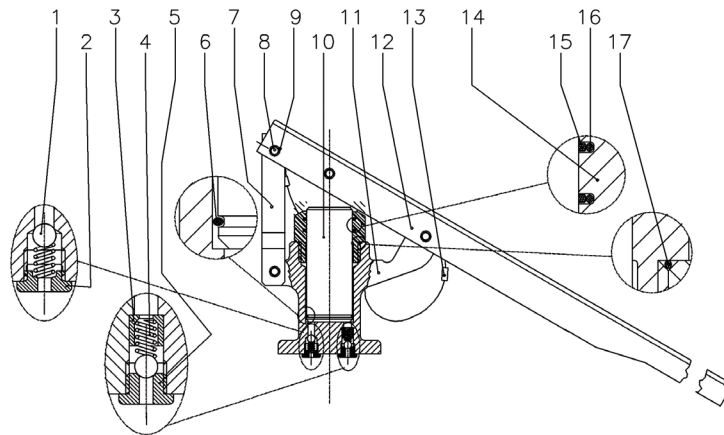
**Figure 26** Hydraulic control unit - handpump**Table 13.** Parts list - Hydraulic control unit - handpump

Item	Qty	Description	Material
1	2	Ball	Stainless steel
2	1	Delivery valve bush	Carbon steel
3	1	Suction valve bush	Carbon steel
4	2	Spring	Stainless steel
5	1	Suction valve seat	Carbon steel
6	1	Spring retainer ring	Carbon steel
7	1	Fork	Carbon steel
8	3	Pin	Stainless steel
9	6	Retainer ring	Carbon steel
10	1	Rod	Alloy steel (chromium plated)
11	1	Body	Carbon steel
12	1	Lever	Carbon steel
13	1	Split pin with rope	Carbon steel + nylon
14	1	Threaded bush	Aluminium
15	2	Rod seal ring	Teflon + graphite
16	2	O-ring	Fluorosilicon rubber*
17	1	O-ring	Fluorosilicon rubber*

**NOTE:**

\* Recommended spare parts

Figure 27 Mechanical manual override

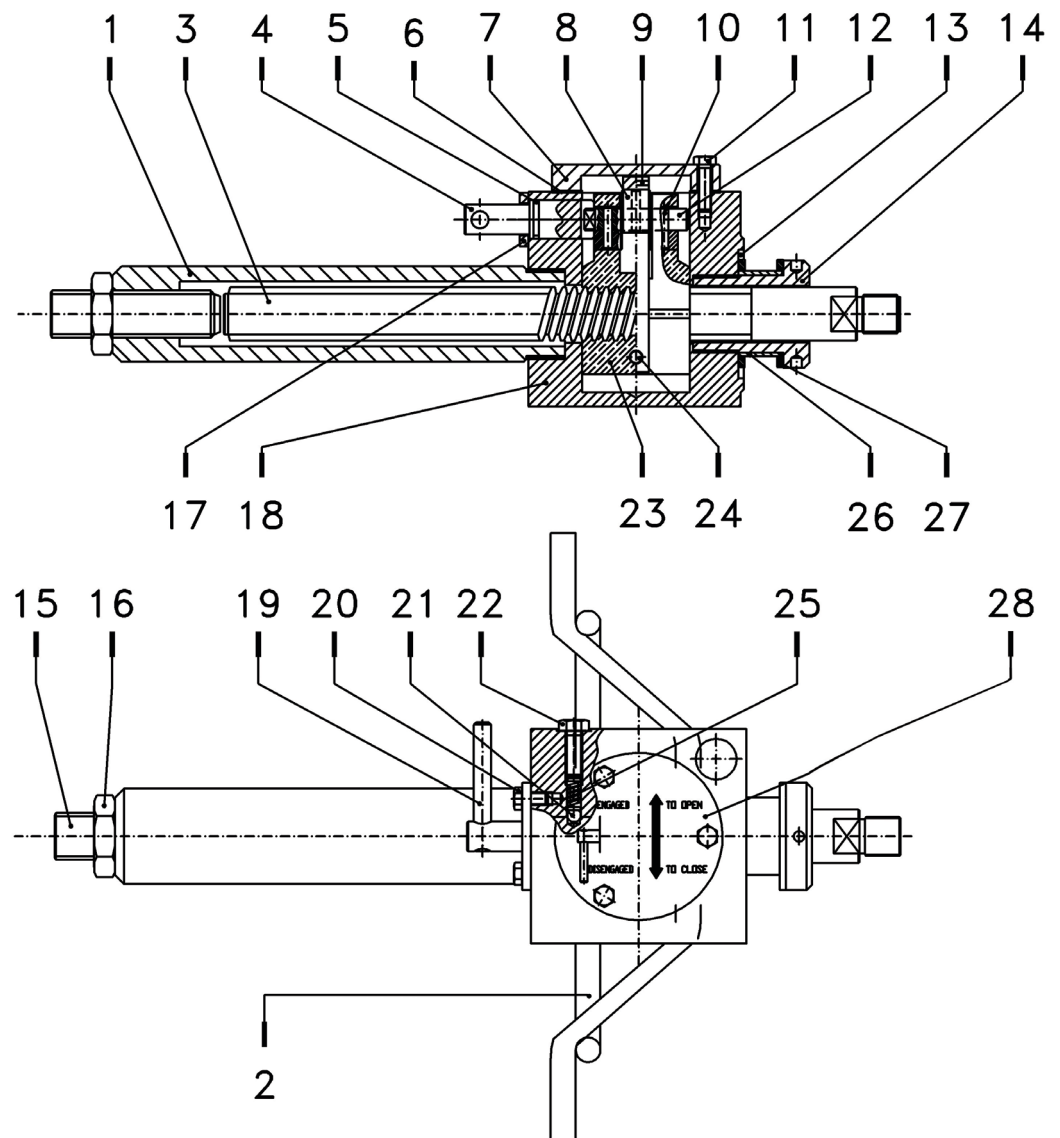

Table 14. Parts list -Jackscrew manual override MSJ

Item	Qty	Description	Material
1	1	Protection pipe	Carbon steel
2	1	Handwheel manual override Ø1250	Stainless steel
3	1	Jack screw	Carbon steel
4	1	Engagement lever pin	Stainless steel
5	1	O-ring	Fluorosilicon rubber*
6	1	Cover gasket	Fiber*
7	1	Cover	Carbon steel
8	3	Cam	Alloy steel
9	1	Fork	Carbon steel
10	3	Spring pin	Stainless steel
11	3	Screw	Carbon steel
12	1	Cams pin	Alloy steel
13	1	O-ring	Fluorosilicon rubber*
14	1	Thrust block ring nut	Alloy steel
15	1	Screw	Carbon steel
16	1	Nut	Carbon steel
17	1	Flange	Carbon steel
18	1	Body	Carbon steel
19	1	Spring pin	Spring steel
20	2	Screw	Carbon steel
21	1	Ball ¼"	Stainless steel
22	1	Screw	Carbon steel
23	1	Screw nut	Bronze
24	1	Pin	Carbon steel
25	1	Spring	Spring steel
26	1	Bush	Bronze
27	2	Thrust shoulder washer	Bronze
28	1	Operating instruction plate	Aluminium

**NOTE:**

\* Recommended spare parts

# Section 8: Date Report for Maintenance Operations

Last maintenance operation date: (in factory, on delivery):  
..... exec. by : .....  
..... exec. by : .....  
..... exec. by : .....

Next maintenance operation date: ..... exec. by : .....  
..... exec. by : .....  
..... exec. by : .....

Start-up date: ..... (in factory, on delivery) .....  
..... (on plant) .....

Biffi Italia s.r.l.  
Strada Biffi 165  
29017 Fiorenzuola d'Arda (PC)  
Italy  
T +39 0523 944 411

For complete list of sales and manufacturing sites, please visit  
[www.biffi.it](http://www.biffi.it) or contact us at [biffi\\_italia@biffi.it](mailto:biffi_italia@biffi.it)

VCIOM-15200-EN ©2020 Biffi. All rights reserved.

The contents of this publication are presented for information purposes only, and while every effort has been made to ensure their accuracy, they are not to be construed as warranties or guarantees, express or implied, regarding the products or services described herein or their use or applicability. All sales are governed by our terms and conditions, which are available on request. We reserve the right to modify or improve the designs or specifications of our products at any time without notice.

