

MDE 248

ECU1000 HART 7 Interface

HRT_ECU1000 User Manual

Rev.	Date	Description	Prepared	Approved
1	07/11/2017	Added details to Device Variables Table	<i>L. Piacenti</i>	<i>A. Battaglia</i>
0	05/07/2017	First Issue	<i>L. Piacenti</i>	<i>A. Battaglia</i>

BIFFI ITALIA has taken every care in collecting and verifying the documentation contained in this Installation and User Manual.

The informations herein contained are reserved property of BIFFI ITALIA.

INDEX

1	INTRODUCTION	6
2	REFERENCE DOCUMENTS	6
3	OPERATION AND STORAGE	6
4	COMMUNICATION FEATURES	7
5	HART MODULE	8
5.1	Analog control signal	9
5.2	Process Variables	9
6	HART PROTOCOL PREVIEWS	10
6.1	HART wirings	11
7	HART COMMANDS	12
8	HART COMMAND SET	17
8.1	Universal Commands	17
8.1.1	Command #0: Read Unique Identifier	18
8.1.2	Command #1: Read Primary Variable	19
8.1.3	Command #2: Read Loop Current and Percent of Range	20
8.1.4	Command #3: Read Dynamic Variables and Loop Current	21
8.1.5	Command #6: Write Polling Address	22
8.1.6	Command #7: Read Loop Configuration	23
8.1.7	Command #8: Read Dynamic Variable Classifications	24
8.1.8	Command #9: Read Device Variables with Status	25
8.1.9	Command #11: Read Unique Identifier associated with Tag	27
8.1.10	Command 12: Read Message	28
8.1.11	Command #13: Tag, Descriptor, Date	29
8.1.12	Command #14: Read Primary Variable Transducer Information	30
8.1.13	Command #15: Read Device Information	31
8.1.14	Command #16: Read Final Assembly Number	32
8.1.15	Command #17: Write Message	33
8.1.16	Command #18: Write Tag, Descriptor, Date	34
8.1.17	Command #19: Write Final Assembly Number	35
8.1.18	Command #20: Read Long Tag	36
8.1.19	Command #21: Read Unique Identifier associated with Long Tag	37
8.1.20	Command #22: Write Long Tag	38
8.1.21	Command #38: Reset Configuration Changed Flag	39
8.1.22	Command #48: Read Additional Device Status	40
8.2	Common Practice Commands	45
8.2.1	Command #42: Perform Device Reset	46
8.2.2	Command #50: Read Dynamic Variable Assignments	47
8.2.3	Command #51: Write Dynamic Variable Assignments	48
8.2.4	Command #54: Read Device Variable Information	50
8.2.5	Command #59: Write Number of Response Preambles	51
8.2.6	Command #79: Write Device Variable	52
8.2.7	Command #95: Read Device Communication Statistics	53

8.2.8	Command #103: Write Burst Period	54
8.2.9	Command #104: Write Burst Trigger	55
8.2.10	Command #105: Read Burst Mode Configuration	57
8.2.11	Command #107: Write Burst Device Variables	58
8.2.12	Command #108: Write Burst Mode Command Number	59
8.2.13	Command #109: Burst Mode Control	60
8.3	Device Specific Commands	61
8.3.1	Command #128: Read Parameter2	62
8.3.2	Command #131: Write Parameter2	63
8.3.3	Command #130: Read ParameterE	64
8.3.4	Command #131: Write ParameterE	65
8.3.1	Command #132: Read ParameterBE	66
8.3.2	Command #133: Write ParameterBE	67
8.3.3	Command #134: Read ParameterF	68
8.3.4	Command #135: Write ParameterF	69
8.3.5	Command #136: Read Dates	70
8.3.6	Command #137: Write Dates	71
8.3.7	Command #138: Read Times	72
8.3.8	Command #139: Write Times	73
8.3.9	Command #140: Read String16	74
8.3.10	Command #141: Write String16	75
8.3.11	Command #142: Read String12	76
8.3.12	Command #143: Read Failure Log	77
8.3.13	Command #144: Read Alarm Log	78
8.3.14	Command #145: Read Event Log	79
8.3.15	Command #146: Read CurveID and Type	80
8.3.16	Command #147: Write CurveID and Type	81
8.3.17	Command #148: Read Curve Data Header	82
8.3.18	Command #149: Read Curve Samples Axis-1 – Part 1	83
8.3.19	Command #150: Read Curve Samples Axis-1 – Part 2	85
8.3.20	Command #151: Read Curve Samples Axis-1 – Part 3	87
8.3.21	Command #152: Read Curve Samples Axis-1 – Part 4	89
8.3.22	Command #153: Read Curve Samples Axis-2 – Part 1	91
8.3.23	Command #154: Read Curve Samples Axis-2 – Part 2	93
8.3.24	Command #155: Read Curve Samples Axis-2 – Part 3	95
8.3.25	Command #156: Read Curve Samples Axis-2 – Part 4	97
8.3.26	Command #157: Read Curve Samples Axis-3 – Part 1	99
8.3.27	Command #158: Read Curve Samples Axis-3 – Part 2	101
8.3.28	Command #159: Read Curve Samples Axis-3 – Part 3	103
8.3.29	Command #160: Read Curve Samples Axis-3 – Part 4	105
8.3.30	Command #161: Read Curve Samples Axis-4 – Part 1	107
8.3.31	Command #162: Read Curve Samples Axis-4 – Part 2	109
8.3.32	Command #163: Read Curve Samples Axis-4 – Part 3	111
8.3.33	Command #164: Read Curve Samples Axis-4 – Part 4	113
8.3.34	Command #165: Read Curve Samples Axis-5 – Part 1	115
8.3.35	Command #166: Read Curve Samples Axis-5 – Part 2	117
8.3.36	Command #167: Read Curve Samples Axis-5 – Part 3	119
8.3.37	Command #168: Read Curve Samples Axis-5 – Part 4	121
8.4	Common Tables	123
9	DEVICE VARIABLES	128
9.1	List of Device Variables	128
9.2	Device Variable Status Byte	129
9.3	Device Variable 0: Actuator Position	130
9.4	Device Variable 1: Position Demand	130
9.5	Device Variable 2: Demand Source	130
9.6	Device Variable 3: Status Summary	130

9.7	Device Variable 4: Remote Not Available	130
9.8	Device Variable 5: Maintenance Request	131
9.9	Device Variable 6: Status1	131
9.10	Device Variable 7: Status2	132
9.11	Device Variable 8: Failure	132
9.12	Device Variable 9: Alarm1	133
9.13	Device Variable 10: Alarm2	133
9.14	Device Variable 11: Alarm3	134
9.15	Device Variable 12: Oil Pressure	134
9.16	Device Variable 13: Temperature	134
9.17	Device Variable 14: Humidity	134
9.18	Device Variable 15: Process AI	134
9.19	Device Variable 16: Interlock AI	134
9.20	Device Variable 17: Next Pump Switch - Hours	135
9.21	Device Variable 18: Next Pump Switch - Minutes	135
9.22	Device Variable 19: Pressure1	135
9.23	Device Variable 20: Pressure2	135
9.24	Device Variable 21: Actuator Command 1	135
9.25	Device Variable 22: Actuator Command 2	135
9.26	Device Variable 23: Actuator Command 3	136
9.27	Device Variable 24: Actuator Command 4	136
9.28	Device Variable 25: Clear Failure/Alarm	136
9.29	Device Variable 244: Percent Range	136
9.30	Device Variable 245: Loop Current	136
9.31	Device Variable 246: Primary Variable	137
9.32	Device Variable 247: Secondary Variable	137
9.33	Device Variable 248: Tertiary Variable	137
9.34	Device Variable 249: Quaternary Variable	137
10	DEVICE SPECIFIC TABLES	138
10.1	Parameter2 Codes	138
10.2	ParameterE Codes	139
10.2.1	ParameterE Tables	139
10.3	ParameterBE Codes	141
10.3.1	Table BE1	141
10.4	ParameterF Codes	141
10.5	Date Codes	141
10.6	Time Codes	142
10.7	String16 Codes	142
10.8	String12 Codes	142
10.9	Failure Codes	142
10.10	Alarm Codes	143
10.11	Event Action	144
10.12	Event Codes	144
10.13	Curve Type	144

10.14	Axis Variable	145
10.15	Axis Engineering Unit Codes	145
11	BUS MENU	146

1 INTRODUCTION

The HRT_ECU1000 is an electronic module that allows connecting the Biffi actuator ECU1000 to an HART serial communication line. The module complies with HART Protocol Revision 7.5.

The HRT_ECU1000 has its microprocessor, it's controlled by a program stored internally, it works as a pure bus interface and does not affect the actuator control integrity. It is installed inside the actuator housing and the communication interface is powered from the actuator power supply module. The HART hardware modem is located on the module board. The data lines are fully isolated from the actuator electronics.

2 Reference Documents

- [1] *DTDE300 ECU1000 Product Description*
- [2] *DTDE326 ECU1000 Installation and Maintenance Manual*
- [3] *DTDE327 ECU1000 Control functions and Local Operator Interface*
- [4] *DTDE328 ECU1000 Functions Description*
- [5] *DTDE330 ECU1000 Biffi Assistant*

3 Operation and storage

The module is designed to work and to be stored in the same environment of the actuator.

4 COMMUNICATION FEATURES

Communication Protocol:	HART Protocol Revision 7.5	
Electrical Interface:	4-20mA analog loop, 2 wire communication	
HART Signal:	Digital FSK Frequency Shift Keying (Bell 202 Standard)	
Logical “0” frequency:	2200Hz	
Logical “1” frequency:	1200Hz	
Data rate:	Request/Response mode – 2/3 updates per seconds Optional Burst mode – 3/4 updates per seconds	
Data transmission:	Master / Slave and Burst communication modes	
Data byte structure:	1 start bit, 8 data bits, 1 odd parity bit, 1 stop bit	
Command Structure:	Type of command	Structure
	UNIVERSAL	Common to all devices
	COMMON PRACTICE	Optional, used by many devices
	DEVICE SPECIFIC	For unique product features
HART Topology:	Point to point, Multidrop, Series Connection	
Electrical power:	Bus powered Max Voltage 26.4V Min Voltage 19.2V	
Max Load (cable + resistor) :	300 Ω	
Device Type:	Actuator	
Device Impedance:	Low impedance	
Temperature:	-40°C, +75°C	
Reversed polarity protection:	Present	
EMC protections:	According to generic standard for industrial environments EN61000-6-2 and EN61000-6-4	
Manufacturer ID Code:	183 (B7 Hex)	
Device Type Code:	123 (7B Hex)	

5 HART MODULE

The module consists in a single PCB that is installed inside the actuator housing. It is connected to the ECU1000 base card via strip connector.

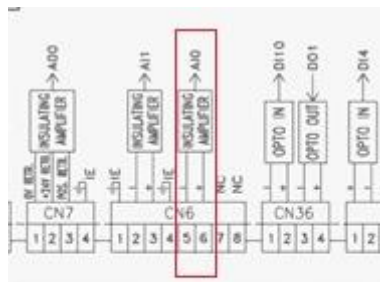
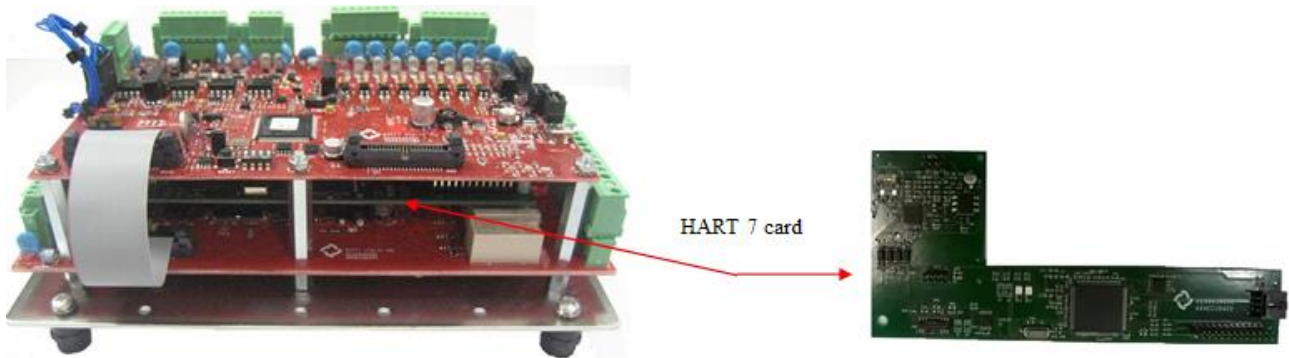

HART 7 signal on the same loop of AI0 (pin 5-6 of CN6)

5.1 Analog control signal

Maximum Current	21.5 mA	
Minimum Current	3.5 mA	
Multidrop Current	4.0 mA	
Input Impedance	450 Ω	(in loop control mode)
Input Capacitance	30000pF	(in loop control mode)

5.2 Process Variables

Default Process Variables are:

PV	Position Demand
PV loop current	Analogue 4-20mA input signal in mA
SV	Actuator Position
TV	Status Summary
QV	Maintenance Request

Process variables can be changed by Command #51 (see Section 8.2.3 for details).

6 HART PROTOCOL PREVIEWES

The HART bus combines the familiarity of using the 4-20mA signals with the benefits of the bus technology. In fact, by means of the simultaneous analogue and digital signals, additional information can be carried out on the same pair of wires together with the analogue 4-20mA signal. The digital communication signal has a response time of approximately 2-3 data updates per second without interrupting the analog signal.

HART is typically a request-response communication protocol, which means that during normal operation (2-3 data updates per second), each field device communication is initiated by a host communication device. Two hosts can connect to each HART loop. The primary host is generally a distributed control system (DCS), programmable logic controller (PLC), or a personal computer (PC). Our actuator interface is a transmitter field device.

The HRT_ECU1000 Module supports the optional burst communication mode. Burst mode enables faster communication (3-4 data updates per second). In burst mode, the host instructs the field device to continuously broadcast a standard HART reply message (e.g., the value of the process variable). The host receives the message at the higher rate until it instructs the device to stop bursting.

The HART Communication Protocol is based on the Bell 202 telephone communication standard and operates using the frequency shift keying (FSK) principle. The digital signal is made up of two frequencies 1200 Hz and 2200 Hz representing bits 1 and 0, respectively. Sine waves of these two frequencies are superimposed on the direct current analog signal cables to provide simultaneous analog and digital communications. Because the average value of the FSK signal is always zero, the 4-20mA analog signal is not affected.

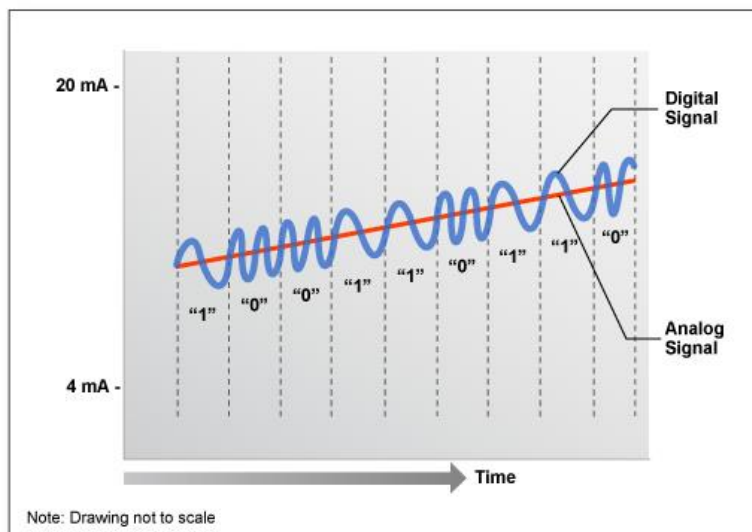

Digital over Analog

More information about HART is available in the official website <https://fieldcommgroup.org/>.

6.1 HART wirings

According to HART specification the following working modes are available: point to point and multidrop.

The factory configuration is POINT to POINT.

- **POINT TO POINT**

In point to point mode, the 4-20mA signal is used to communicate one process variable, while additional process variables, configuration parameters, and other device data are transferred digitally using the HART Protocol. The 4-20mA analog signal is not affected by the HART signal and can be used for control. The HART communication digital signal gives access to secondary variables and other data that can be used for operations, commissioning, maintenance and diagnostic purposes.

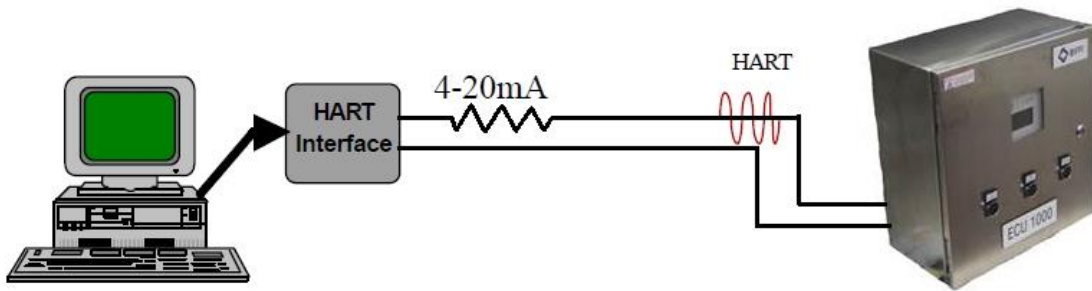

- **MULTIDROP**

The Multidrop Mode requires only a single pair of wires and can control up to 16 devices connected in parallel. All process values are transmitted digitally. In Multidrop mode, each field device must have a unique polling address, different from each other in the range 0-15. The current of the loop is fixed to a minimum value (typically 4mA for each device).

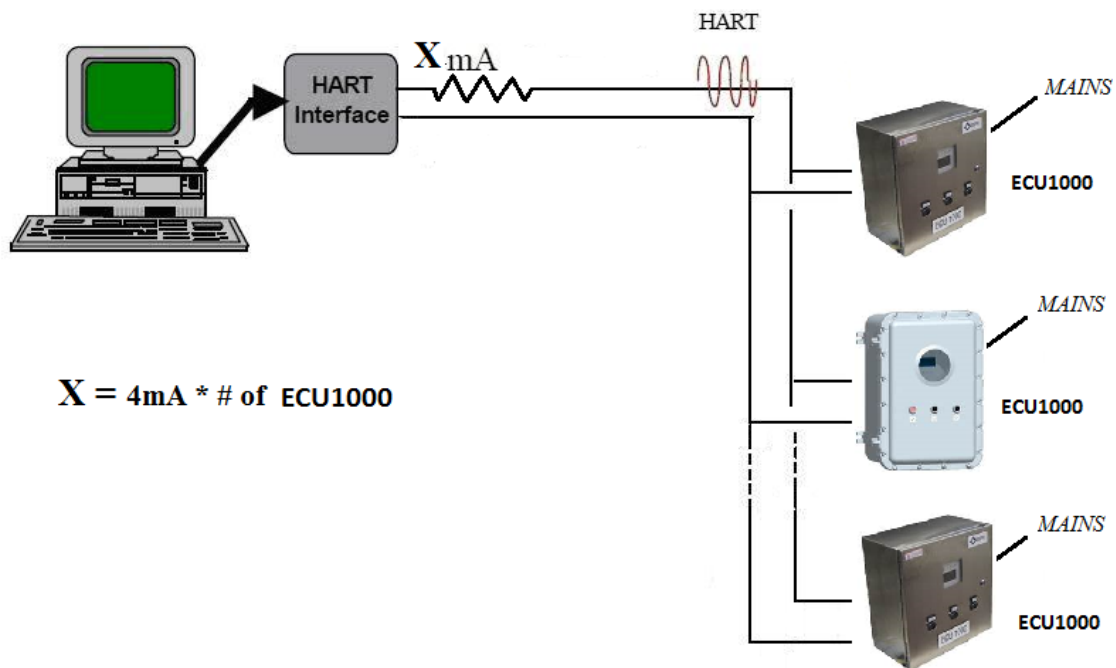

7 HART COMMANDS

The HART Command Set provides uniform and consistent communication for all field devices. The command set includes three classes: Universal, Common Practice, and Device Specific. Host applications may implement any of the necessary commands for a particular application.

- **UNIVERSAL**

All devices using the HART Protocol must recognize and support the universal commands. Universal commands provide access to information useful in normal operations (e.g., read primary variable and units).

Universal Commands	
0	Read Unique Identifier
1	Read Primary Variable
2	Read Loop Current and Percent of Range
3	Read Dynamic Variables and Loop Current
6	Write Polling Address
7	Read Loop Configuration
8	Read Dynamic Variable Classifications
9	Read Device Variables with Status
11	Read Unique Identifier Associated With Tag
12	Read Message
13	Read Tag, Descriptor, Date
14	Read Primary Variable Transducer Information
15	Read Device Information
16	Read Final Assembly Number
17	Write Message
18	Write Tag, Descriptor, Date
19	Write Final Assembly Number
20	Read Long Tag
21	Read Unique Identifier Associated With Long Tag
22	Write Long Tag
38	Reset Configuration Changed Flag
48	Read Additional Device Status

- **COMMON PRACTICE**

Common Practice commands provide functions implemented by many, but not necessarily all, HART communication devices.

Common Practice Commands	
42	Perform Device Reset
50	Read Dynamic Variable Assignment
51	Write Dynamic Variable Assignment
54	Read Device Variable Information
59	Write Number of Response Preamble
79	Write Device Variable
95	Read Device Communication Statistics
103	Write Burst Period
104	Write Burst Trigger
105	Read Burst Mode Configuration
107	Write Burst Device Variables
108	Write Burst Mode Command Number
109	Burst Mode Control

- **DEVICE SPECIFIC**

Device Specific commands represent functions that are unique to each field device. These commands access setup and calibration information, as well as information about the construction of the device. Information on Device Specific commands is available from device manufacturers.

Device Specific Commands	
128	Read Parameters2
129	Write Parameters2
130	Read ParametersE
131	Write ParametersE
132	Read ParametersBE
133	Write ParametersBE
134	Read ParametersF
135	Write ParametersF
136	Read Date
137	Write Dates
138	Read Times
139	Write Times
140	Read String16
141	Write String16
142	Read String12
143	Read Failure Log
144	Read Alarm Log
145	Read Event Log
146	Read Curve ID and Type
147	Write Curve ID and Type
	Continue...

Device Specific Commands

...Continue

148 Read Header Curve

149 Read Axis-1 Samples – Part1

150 Read Axis-1 Samples – Part2

151 Read Axis-1 Samples – Part3

152 Read Axis-1 Samples – Part4

153 Read Axis-2 Samples – Part1

154 Read Axis-2 Samples – Part2

155 Read Axis-2 Samples – Part3

156 Read Axis-2 Samples – Part4

157 Read Axis-3 Samples – Part1

158 Read Axis-3 Samples – Part2

159 Read Axis-3 Samples – Part3

160 Read Axis-3 Samples – Part4

161 Read Axis-4 Samples – Part1

162 Read Axis-4 Samples – Part2

163 Read Axis-4 Samples – Part3

164 Read Axis-4 Samples – Part4

165 Read Axis-5 Samples – Part1

166 Read Axis-5 Samples – Part2

167 Read Axis-5 Samples – Part3

168 Read Axis-5 Samples – Part4

All slave response messages return two Command Status bytes in the first two bytes of the Data field. The first byte is multiplexed and contains either the Communication Status (most significant bit is set) or the Response Code (most significant bit is reset). The second byte of a slave response message always contains Field Device Status.

The Response Data Bytes are not returned if a communications or command error is reported in the Command Status Bytes.

The **Communication Status** is returned if a communication error is detected by the field device.

Bit Mask	Communication Status Definition
0x80	1 – this bit is always set to indicate a communication error
0x40	Vertical Parity Error – the parity of one or more of the bytes received by the device was not odd.
0x20	Overrun Error – At least one byte of data in the receive buffer of the UART was overwritten before it was read.
0x10	Framing Error – the Stop Bit of one or more bytes received by the device was not detected by the UART.
0x08	Longitudinal Parity Error – the Longitudinal Parity calculated by the device did not match the Check Byte at the end of the message.
0x04	Reserved – always 0
0x02	Buffer Overflow – the message was too long for the receive buffer of the device.
0x01	Reserved – always 0

If no communication errors are detected the first byte in the Data Field contains the **Response Code**. The Response Code describes the result of the executed command. The Response Code is encoded as a 7-bit enumeration (between 0 and 127).

There are 3 Classification Response Codes:

- **Notification:** the command sent by the Master is executed properly by the Slave.
- **Warning:** the command sent by the Master is executed with the deviation as described in the response.
- **Error:** the command sent by the Master was not properly completed and the Response Code indicates the reason.

See the appropriate Response Code Table for each command.

The second data byte in a Slave-to-Master frame is a bit field table that represent the current operating status of the slave.

Bit Mask	Communication Status Definition
0x80	Device Malfunction – The device detected a serious error or failure that compromises device operation.
0x40	Configuration Changed – An operation was performed that changed the device’s configuration.
0x20	Cold Start – A power failure or Device Reset has occurred.
0x10	More Status Available – More status information is available via command 48, Read Additional Device Status
0x08	Loop Current Fixed – The Loop Current is being held at a fixed value and is not responding to process variations.
0x04	Loop Current Saturated – The Loop Current has reached its upper (or lower) endpoint limit and cannot increase (or decrease) any further.
0x02	Non-Primary Variable Out of Limits – A Device Variable not mapped to PV is beyond its operating limits.
0x01	Primary Variable Out of Limits – The PV is beyond its operating limit.

Device Malfunction bit is set if a generic alarm or warning is active, maintenance operation is required, one or more device variables are not loaded by the logic card or Main Voltage alarm is active.

Configuration Changed bit is set if one or more parameters are modified.

Cold Start bit is set after a power on or reset operation has occurred.

More Status Available bit is set if additional device status data bytes are changed.

Loop Current Fixed bit is set if Loop Current Mode is disabled.

Loop Current Saturated bit is set if Loop Current value reached 20mA.

“Non-Primary Variable Out of Limits” and “Primary variable Out of Limits” bits are not used. These bits are always set to 0.

8 HART COMMAND SET

8.1 Universal Commands

N°	Command Description
0	Read Unique Identifier
1	Read Primary Variable
2	Read Loop Current and Percent of Range
3	Read Dynamic Variables and Loop Current
6	Write Polling Address
7	Read Loop Configuration
8	Read Dynamic Variable Classifications
9	Read Device Variables with Status
11	Read Unique Identifier Associated with Tag
12	Read Message
13	Read Tag, Descriptor, Date
14	Read Primary Variable Transducer Information
15	Read Device Information
16	Read Final Assembly Number
17	Write Message
18	Write Tag, Descriptor, Date
19	Write Final Assembly Number
20	Read Long Tag
21	Read Unique Identifier Associated with long Tag
22	Write Long Tag
38	Reset Configuration Changed Flag
48	Read Additional Device Status

8.1.1 Command #0: Read Unique Identifier

This command returns identity information about the field device including: Device Type, revision levels, and Device ID.

Request Data Bytes

Byte	Format	Description
None		

Response Data Bytes

Byte	Format	Description
0	Unsigned-8	"254" – Fixed Value
1-2	Enum	Expanded Device Type Code (see Section 8.4, Table 1)
3	Unsigned-8	5 = Minimum number of preambles required for the request message from the Master to the Slave
4	Unsigned-8	7 = HART Protocol Major Revision
5	Unsigned-8	Device Revision
6	Unsigned-8	Software Revision
7	Unsigned-5	MSB (5 bits) – Hardware Revision
7	Enum	LSB (3 bits) – Physical Signalling Code (see Section 8.4, Table 10)
8	Bits	Flag Assignment (see Section 8.4, Table 11)
9-11	Unsigned-24	Device ID
12	Unsigned-8	Minimum Number of preambles to be sent with the response message from the Slave to the Master.
13	Unsigned-8	Maximum Number of Device Variables.
14-15	Unsigned-16	Configuration Change Counter
16	Bits	Extended Field Device Status (see Section 8.4, Table 17)
17-18	Enum	Manufacturer Identification Code (see Section 8.4, Table 8)
19-20	Enum	Private Label Distributor Code (see Section 8.4, Table 8)
21	Enum	Device Profile (see Section 8.4, Table 57)

Command-Specific Response Codes

Code	Class	Description
0	Success	No Command-Specific Errors
1-127		Undefined

8.1.2 Command #1: Read Primary Variable

This command returns the Primary Variable value whit its Unit Code.

Request Data Bytes

Byte	Format	Description
None		

Response Data Bytes

Byte	Format	Description
0	Enum	Primary Variable Units Code (see Section 8.4, Table 2)
1-4	Float	Primary Variable

Command-Specific Response Codes

Code	Class	Description
0	Success	No Command-Specific Errors
1-5		Undefined
6	Error	Device-Specific Command Error
7		Undefined
8	Warning	Update Failure
9-15		Undefined
16	Error	Access Restricted
1-127		Undefined

8.1.3 Command #2: Read Loop Current and Percent of Range

This command reads the Loop Current and its associated Percent of Range.

Request Data Bytes

Byte	Format	Description
None		

Response Data Bytes

Byte	Format	Description
0-3	Float	Primary Variable Loop Current (units of mA)
4-7	Float	Primary Variable Percent of Range (units of percent)

Command-Specific Response Codes

Code	Class	Description
0	Success	No Command-Specific Errors
1-5		Undefined
6	Error	Device-Specific Command Error
7		Undefined
8	Warning	Update Failure
9-15		Undefined
16	Error	Access Restricted
17-127		Undefined

8.1.4 Command #3: Read Dynamic Variables and Loop Current

This command reads the Loop Current and the four Dynamic Variables.

Request Data Bytes

Byte	Format	Description
None		

Response Data Bytes

Byte	Format	Description
0-3	Float	Primary Variable Loop Current (units of mA)
4	Enum	Primary Variable Units Code (see Section 8.4, Table 2)
5-8	Float	Primary Variable
9	Enum	Secondary Variable Units Code (see Section 8.4, Table 2)
10-13	Float	Secondary Variable
14	Enum	Tertiary Variable Units Code (see Section 8.4, Table 2)
15-18	Float	Tertiary Variable
19	Enum	Quaternary Variable Units Code (see Section 8.4, Table 2)
20-23	Float	Quaternary Variable

Command-Specific Response Codes

Code	Class	Description
0	Success	No Command-Specific Errors
1-5		Undefined
6	Error	Device-Specific Command Error
7		Undefined
8	Warning	Update Failure
9-15		Undefined
16	Error	Access Restricted
17-127		Undefined

8.1.5 Command #6: Write Polling Address

This command permits to write the Polling Address and the Loop Current mode to the field device.

Request Data Bytes

Byte	Format	Description
0	Unsigned-8	Polling Address of Device
1	Enum	Loop Current Mode (see Section 8.4, Table 16)

Response Data Bytes

Byte	Format	Description
0	Unsigned-8	Polling Address of Device
1	Enum	Loop Current Mode (see Section 8.4, Table 16)

Command-Specific Response Codes

Code	Class	Description
0	Success	No Command-Specific Errors
1		Undefined
2	Error	Invalid Poll Address Selection
3-4		Undefined
5	Error	Too Few Data Bytes Received
6	Error	Device-Specific Command Error
7	Error	In Write Protect Mode
8-11		Undefined
12	Error	Invalid Mode Selection
13-15		Undefined
16	Error	Access Restricted
17-31		Undefined
32	Error	Busy
33-127		Undefined

8.1.6 Command #7: Read Loop Configuration

This command reads the Polling Address and the Loop Current mode.

Request Data Bytes

Byte	Format	Description
None		

Response Data Bytes

Byte	Format	Description
0	Unsigned-8	Polling Address of Device
1	Enum	Loop Current Mode (see Section 8.4, Table 16)

Command-Specific Response Codes

Code	Class	Description
0	Success	No Command-Specific Errors
1-15		Undefined
16	Error	Access Restricted
17-127		Undefined

8.1.7 Command #8: Read Dynamic Variable Classifications

This command reads the classification associated with the Dynamic Variables.

Request Data Bytes

Byte	Format	Description
None		

Response Data Bytes

Byte	Format	Description
0	Enum	Primary Variable Classification (see Section 8.4, Table 21)
1	Enum	Secondary Variable Classification (see Section 8.4, Table 21)
2	Enum	Tertiary Variable Classification (see Section 8.4, Table 21)
3	Enum	Quaternary Variable Classification (see Section 8.4, Table 21)

Command-Specific Response Codes

Code	Class	Description
0	Success	No Command-Specific Errors
1-15		Undefined
16	Error	Access Restricted
17-127		Undefined

8.1.8 Command #9: Read Device Variables with Status

This command allows a Master to request the value and status of up to 8 Device or Dynamic Variables.

If the Field Device receives 1, 2, 3, 4, 5, 6, or 7 Request Data Bytes it returns only the corresponding number of Device Variables.

N. of Device Variables Requested	N. of Request Data Bytes	N. Response Data Bytes
1	1	13
2	2	21
3	3	29
4	4	37
5	5	45
6	6	53
7	7	61
8	8	69

Request Data Bytes

Byte	Format	Description
0	Unsigned-8	Slot 0: Device Variable Code (see Section 9.1)
1	Unsigned-8	Slot 1: Device Variable Code (see Section 9.1)
2	Unsigned-8	Slot 2: Device Variable Code (see Section 9.1)
3	Unsigned-8	Slot 3: Device Variable Code (see Section 9.1)
4	Unsigned-8	Slot 4: Device Variable Code (see Section 9.1)
5	Unsigned-8	Slot 5: Device Variable Code (see Section 9.1)
6	Unsigned-8	Slot 6: Device Variable Code (see Section 9.1)
7	Unsigned-8	Slot 7: Device Variable Code (see Section 9.1)

Response Data Bytes

Byte	Format	Description
0	Bits	Extended Field Device Status (see Section 8.4, Table 17)
1	Unsigned-8	Slot 0: Device Variable Code (see Section 9.1)
2	Enum	Slot 0: Device Variable Classification (see Section 8.4, Table 21)
3	Enum	Slot 0: Units Code (see Section 8.4, Table 2)
4-7	Float	Slot 0: Device Variable Value
8	Bits	Slot 0: Device Variable Status (see Section 9.2)
9	Unsigned-8	Slot 1: Device Variable Code (see Section 9.1)
10	Enum	Slot 1: Device Variable Classification (see Section 8.4, Table 21)
11	Enum	Slot 1: Units Code (see Section 8.4, Table 2)
12-15	Float	Slot 1: Device Variable Value
16	Bits	Slot 1: Device Variable Status (see Section 9.2)
17	Unsigned-8	Slot 2: Device Variable Code (see Section 9.1)
18	Enum	Slot 2: Device Variable Classification (see Section 8.4, Table 21)
19	Enum	Slot 2: Units Code (see Section 8.4, Table 2)
20-23	Float	Slot 2: Device Variable Value
24	Bits	Slot 2: Device Variable Status (see Section 9.2)
25	Unsigned-8	Slot 3: Device Variable Code (see Section 9.1)

26	Enum	Slot 3: Device Variable Classification (see Section 8.4, Table 21)
27	Enum	Slot 3: Units Code (see Section 8.4, Table 2)
28-31	Float	Slot 3: Device Variable Value
32	Bits	Slot 3: Device Variable Status (see Section 9.2)
33	Unsigned-8	Slot 4: Device Variable Code (see Section 9.1)
34	Enum	Slot 4: Device Variable Classification (see Section 8.4, Table 21)
35	Enum	Slot 4: Units Code (see Section 8.4, Table 2)
36-39	Float	Slot 4: Device Variable Value
40	Bits	Slot 4: Device Variable Status (see Section 9.2)
41	Unsigned-8	Slot 5: Device Variable Code (see Section 9.1)
42	Enum	Slot 5: Device Variable Classification (see Section 8.4, Table 21)
43	Enum	Slot 5: Units Code (see Section 8.4, Table 2)
44-47	Float	Slot 5: Device Variable Value
48	Bits	Slot 5: Device Variable Status (see Section 9.2)
49	Unsigned-8	Slot 6: Device Variable Code (see Section 9.1)
50	Enum	Slot 6: Device Variable Classification (see Section 8.4, Table 21)
51	Enum	Slot 6: Units Code (see Section 8.4, Table 2)
52-55	Float	Slot 6: Device Variable Value
56	Bits	Slot 6: Device Variable Status (see Section 9.2)
57	Unsigned-8	Slot 7: Device Variable Code (see Section 9.1)
58	Enum	Slot 7: Device Variable Classification (see Section 8.4, Table 21)
59	Enum	Slot 7: Units Code (see Section 8.4, Table 2)
60-63	Float	Slot 7: Device Variable Value
64	Bits	Slot 7: Device Variable Status (see Section 9.2)
65-68	Time	Slot 0 Data Time Stamp

Command-Specific Response Codes

Code	Class	Description
0	Success	No Command-Specific Errors
1		Undefined
2	Error	Invalid Selection
3-4		Undefined
5	Error	Too Few Data Bytes Received
6	Error	Device-Specific Command Error
7		Undefined
8	Warning	Update Failure
9-13		Undefined
14	Warning	Dynamic Variables Returned for Device Variables
15		Undefined
16	Error	Access Restricted
17-29		Undefined
30	Warning	Command Response Truncated
31-127		Undefined

8.1.9 Command #11: Read Unique Identifier associated with Tag

This command returns identity information about the field device including: Device Type, revision levels, and Device ID.

Request Data Bytes

Byte	Format	Description
0-5	Packed	Tag

Response Data Bytes

Byte	Format	Description
0	Unsigned-8	"254" – Fixed Value
1-2	Enum	Expanded Device Type Code (see Section 8.4, Table 1)
3	Unsigned-8	5 = Minimum number of preambles required for the request message from the Master to the Slave
4	Unsigned-8	7 = HART Protocol Major Revision
5	Unsigned-8	Device Revision
6	Unsigned-8	Software Revision
7	Unsigned-5	MSB (5 bits) – Hardware Revision
7	Enum	LSB (3 bits) – Physical Signalling Code (see Section 8.4, Table 10)
8	Bits	Flag Assignment (see Section 8.4, Table 11)
9-11	Unsigned-24	Device ID
12	Unsigned-8	Minimum Number of preambles to be sent with the response message from the Slave to the Master.
13	Unsigned-8	Maximum Number of Device Variables.
14-15	Unsigned-16	Configuration Change Counter
16	Bits	Extended Field Device Status (see Section 8.4, Table 17)
17-18	Enum	Manufacturer Identification Code (see Section 8.4, Table 8)
19-20	Enum	Private Label Distributor Code (see Section 8.4, Table 8)
21	Enum	Device Profile (see Section 8.4, Table 57)

Command-Specific Response Codes

Code	Class	Description
0	Success	No Command-Specific Errors
1-127		Undefined

8.1.10 Command 12: Read Message

This command reads the Message contained within the field device.

Request Data Bytes

Byte	Format	Description
None		

Response Data Bytes

Byte	Format	Description
0-23	Packed	Message

Command-Specific Response Codes

Code	Class	Description
0	Success	No Command-Specific Errors
1-15		Undefined
16	Error	Access Restricted
17-31		Undefined
32	Error	Busy
33-127		Undefined

8.1.11 Command #13: Tag, Descriptor, Date

This command reads the Tag, Descriptor and Date contained within the field device. Only Tag is read by this command. Tag and Long Tag are completely separate data items.

Request Data Bytes

Byte	Format	Description
None		

Response Data Bytes

Byte	Format	Description
0-5	Packed	Tag
6-17	Packed	Descriptor
18-20	Date	Date Code

Command-Specific Response Codes

Code	Class	Description
0	Success	No Command-Specific Errors
1-15		Undefined
16	Error	Access Restricted
17-31		Undefined
32	Error	Busy
33-127		Undefined

8.1.12 Command #14: Read Primary Variable Transducer Information

This command reads the Transducer Serial Number, Limits/Minimum Span Units Code, Upper Transducer Limit, Lower Transducer Limit, and Minimum Spar for the Primary Variable transducer.

Request Data Bytes

Byte	Format	Description
None		

Response Data Bytes

Byte	Format	Description
0-2	Unsigned-24	Transducer Serial Number
3	Enum	Transducer Limits and Minimum Span units Code (see Section 8.4, Table 2)
4-7	Float	Upper Transducer Limit
8-11	Float	Lower Transducer Limit
12-15	Float	Minimum Span

Command-Specific Response Codes

Code	Class	Description
0	Success	No Command-Specific Errors
1-15		Undefined
16	Error	Access Restricted
17-31		Undefined
32	Error	Busy
33-127		Undefined

8.1.13 Command #15: Read Device Information

This command reads the alarm selection code, transfer function code, range values units code, upper range value, Primary Variable lower range value, damping value and write protect code.

Request Data Bytes

Byte	Format	Description
None		

Response Data Bytes

Byte	Format	Description
0	Enum	PV Alarm Selection Code (see Section 8.4, Table 6)
1	Enum	PV Transfer Function Code (see Section 8.4, Table 3)
2	Enum	PV Upper and Lower Range Values Units Code (see Section 8.4, Table 2)
3-6	Float	PV Upper Range Value
7-10	Float	PV Lower Range Value
11-14	Float	PV Damping Value (units of seconds)
15	Enum	Write Protect Code (see Section 8.4, Table 7)
16	Enum	Reserved. "250"
17	Bits	PV Analog Channel Flags (see Section 8.4, Table 26)

Command-Specific Response Codes

Code	Class	Description
0	Success	No Command-Specific Errors
1-15		Undefined
16	Error	Access Restricted
17-31		Undefined
32	Error	Busy
33-127		Undefined

8.1.14 Command #16: Read Final Assembly Number

This command reads the final assembly number associated within the field device. The Final Assembly Number is used for identifying the materials and electronics that comprise the field device.

Request Data Bytes

Byte	Format	Description
None		

Response Data Bytes

Byte	Format	Description
0-2	Unsigned-24	Final Assembly Number

Command-Specific Response Codes

Code	Class	Description
0	Success	No Command-Specific Errors
1-15		Undefined
16	Error	Access Restricted
17-31		Undefined
32	Error	Busy
33-127		Undefined

8.1.15 Command #17: Write Message

This command permits to write the Message into the field device.

Request Data Bytes

Byte	Format	Description
0-23	Packed	A Message string used by the Master for record keeping

Response Data Bytes

Byte	Format	Description
0-23	Packed	Message string

Command-Specific Response Codes

Code	Class	Description
0	Success	No Command-Specific Errors
1-4		Undefined
5	Error	Too Few Data Bytes Received
6	Error	Device-Specific Command Error
7	Error	In Write Protect Mode
8-15		Undefined
16	Error	Access Restricted
17-31		Undefined
32	Error	Busy
33-127		Undefined

8.1.16 Command #18: Write Tag, Descriptor, Date

This command permits to write the Tag, Descriptor and Date into the field device. Only the Tag is written here. The Tag and Long Tag are completely separate data items.

Request Data Bytes

Byte	Format	Description
0-5	Packed	Tag
6-17	Packed	Descriptor used by the Master for record keeping
18-20	Date	A Date Code used by the Master for record keeping

Response Data Bytes

Byte	Format	Description
0-5	Packed	Tag
6-17	Packed	Descriptor
18-20	Date	Date Code

Command-Specific Response Codes

Code	Class	Description
0	Success	No Command-Specific Errors
1-4		Undefined
5	Error	Too Few Data Bytes Received
6	Error	Device-Specific Command Error
7	Error	In Write Protect Mode
8		Undefined
9	Error	Invalid Date Code Detected
10-15		Undefined
16	Error	Access Restricted
17-31		Undefined
32	Error	Busy
33-127		Undefined

8.1.17 Command #19: Write Final Assembly Number

This command permits to write the Final Assembly Number into the field device.

Request Data Bytes

Byte	Format	Description
0-2	Unsigned-24	Final Assembly Number

Response Data Bytes

Byte	Format	Description
0-2	Unsigned-24	Final Assembly Number

Command-Specific Response Codes

Code	Class	Description
0	Success	No Command-Specific Errors
1-4		Undefined
5	Error	Too Few Data Bytes Received
6	Error	Device-Specific Command Error
7	Error	In Write Protect Mode
8-15		Undefined
16	Error	Access Restricted
17-31		Undefined
32	Error	Busy
33-127		Undefined

8.1.18 Command #20: Read Long Tag

This command reads the Long Tag. Only the Long Tag is read here. The Tag and Long Tag are completely separate data items.

Request Data Bytes

Byte	Format	Description
None		

Response Data Bytes

Byte	Format	Description
0-31	Latin-1	Long Tag

Command-Specific Response Codes

Code	Class	Description
0	Success	No Command-Specific Errors
1-15		Undefined
16	Error	Access Restricted
17-31		Undefined
32	Error	Busy
33-127		Undefined

8.1.19 Command #21: Read Unique Identifier associated with Long Tag

This command returns identity information about the field device including: the Device Type, revision levels and Device ID.

Request Data Bytes

Byte	Format	Description
0-31	Latin-1	Long Tag

Response Data Bytes

Byte	Format	Description
0	Unsigned-8	"254" – Fixed Value
1-2	Enum	Expanded Device Type Code (see Section 8.4, Table 1)
3	Unsigned-8	5 = Minimum number of preambles required for the request message from the Master to the Slave
4	Unsigned-8	7 = HART Protocol Major Revision
5	Unsigned-8	Device Revision
6	Unsigned-8	Software Revision
7	Unsigned-5	MSB (5 bits) – Hardware Revision
7	Enum	LSB (3 bits) – Physical Signalling Code (see Section 8.4, Table 10)
8	Bits	Flag Assignment (see Section 8.4, Table 11)
9-11	Unsigned-24	Device ID
12	Unsigned-8	Minimum Number of preambles to be sent with the response message from the Slave to the Master.
13	Unsigned-8	Maximum Number of Device Variables.
14-15	Unsigned-16	Configuration Change Counter
16	Bits	Extended Field Device Status (see Section 8.4, Table 17)
17-18	Enum	Manufacturer Identification Code (see Section 8.4, Table 8)
19-20	Enum	Private Label Distributor Code (see Section 8.4, Table 8)
21	Enum	Device Profile (see Section 8.4, Table 57)

Command-Specific Response Codes

Code	Class	Description
0	Success	No Command-Specific Errors
1-127		Undefined

8.1.20 Command #22: Write Long Tag

This command allows a Master to write the Long Tag into the field device. Only the Long Tag is written here. The Tag and Long Tag are completely separate data items.

Request Data Bytes

Byte	Format	Description
0-31	Latin-1	Long Tag

Response Data Bytes

Byte	Format	Description
0-31	Latin-1	Long Tag

Command-Specific Response Codes

Code	Class	Description
0	Success	No Command-Specific Errors
1-4		Undefined
5	Error	Too Few Data Bytes Received
6	Error	Device-Specific Command Error
7	Error	In Write Protect Mode
8-15		Undefined
16	Error	Access Restricted
17-31		Undefined
32	Error	Busy
33	Error	Delayed Response Initiated
34	Error	Delayed Response Running
35	Error	Delayed Response Dead
36	Error	Delayed Response Conflict
37-127		Undefined

8.1.21 Command #38: Reset Configuration Changed Flag

This command allows a Master to reset the Configuration Change Flag into the field device.

Request Data Bytes

Byte	Format	Description
0-1	Unsigned-16	Configuration Change Counter

Response Data Bytes

Byte	Format	Description
0-1	Unsigned-16	Configuration Change Counter

Command-Specific Response Codes

Code	Class	Description
0	Success	No Command-Specific Errors
1-5		Undefined
6	Error	Device-Specific Command Error
7	Error	In Write Protect Mode
8		Undefined
9	Error	Configuration Change Counter Mismatch
10-15		Undefined
16	Error	Access Restricted
17-127		Undefined

8.1.22 Command #48: Read Additional Device Status

This command returns the device status information, device specific status information, Extended Device Status, Device Operating Mode and Standardized Status.

Request Data Bytes

Byte	Format	Description
0-5	Bits or Enum	Device-Specific Status
6	Bits	Extended Device Status
7	Bits	Device Operating Mode
8	Bits	Standardized Status 0
9	Bits	Standardized Status 1
10	Bits	Analog Channel Saturated
11	Bits	Standardized Status 2
12	Bits	Standardized Status 3
13	Bits	Analog Channel Fixed
14	Bits	Device-Specific Status1
15	Bits	Device-Specific Status2
16	Bits	Device-Specific Status3
17	Bits	Device-Specific Status4
18	Bits	Device-Specific Status5
19	Bits	Device-Specific Status6
20	Bits	Device-Specific Status7
21	Bits	Device-Specific Status8

See “Request and Response Data Field” table on the next page for details.

Response Data Bytes

Byte	Format	Description
0-5	Bits or Enum	Device-Specific Status
6	Bits	Extended Device Status
7	Bits	Device Operating Mode
8	Bits	Standardized Status 0
9	Bits	Standardized Status 1
10	Bits	Analog Channel Saturated
11	Bits	Standardized Status 2
12	Bits	Standardized Status 3
13	Bits	Analog Channel Fixed
14	Bits or Enum	Device-Specific Status
15	Bits	Device-Specific Status2
16	Bits	Device-Specific Status3
17	Bits	Device-Specific Status4
18	Bits	Device-Specific Status5
19	Bits	Device-Specific Status6
20	Bits	Device-Specific Status7
21	Bits	Device-Specific Status8

See “Request and Response Data Field” table on the next page for details.

Command-Specific Response Codes

Code	Class	Description
0	Success	No Command-Specific Errors
1-5		Undefined
6	Error	Device-Specific Command Error
7		Undefined
8	Warning	Update In Progress
9-15		Undefined
16	Error	Access Restricted
17-127		Undefined

Request and Response Data Field

Byte	Bit	Meaning	Class	Device Status Bits Set
0		Reserved		
1		Reserved		
2		Reserved		
3		Reserved		
4		Reserved		
5		Reserved		
6	0	Maintenance Required	Warning	4, 7
	1	Device Variable Alert	Warning	4, 7
	2	Not used		
	3	Not used		
	4	Not used		
	5	Not used		
	6	Not used		
	7	Not used		
7		Reserved - Not used		
8	0	Not used		
	1	Not used		
	2	Not used		
	3	Not used		
	4	Not used		
	5	Not used		
	6	Not used		
	7	Not used		
9		Not used		
10		Not used		
11		Not used		
12		Not used		
13		Not used		
Continue...				

Byte	Bit	Meaning	Class	Device Status Bits Set
...Continue				
14	0	Actuator Position	Error	4, 7
	1	Position Demand	Error	4, 7
	2	Temperature	Error	4, 7
	3	Proportional Valve	Error	4, 7
	4	Power Supply	Error	4, 7
	5	Hardware 0	Error	4, 7
	6	SW Error	Error	4, 7
	7	HPU Failure	Error	4, 7
15	0	Failsafe	Error	4, 7
	1	Stayput by SOV	Error	4, 7
	2	BUS Control	Error	4, 7
	3	Not Defined	Error	4, 7
	4	Not Defined	Error	4, 7
	5	Not Defined	Error	4, 7
	6	Not Defined	Error	4, 7
	7	Not Defined	Error	4, 7
16	0	High Temperature	Error	4, 7
	1	Low Temperature	Error	4, 7
	2	Stroke Limit	Error	4, 7
	3	Humidity	Error	4, 7
	4	Reserved	Error	4, 7
	5	Reserved	Error	4, 7
	6	Reserved	Error	4, 7
	7	Fail to position	Error	4, 7
17	0	Pump1 Filter	Error	4, 7
	1	Pump2 Filter	Error	4, 7
	2	Oil Level	Error	4, 7
	3	Low Oil Pressure	Error	4, 7
	4	Oil Temperature	Error	4, 7
	5	High Oil Pressure	Error	4, 7
	6	HPU Pressure Transmitter	Error	4, 7
	7	HPU Signalling Switch	Error	4, 7
18	0	HPU General Sensor	Error	4, 7
	1	Pump1 Power Supply	Error	4, 7
	2	Pump1 Motor TH	Error	4, 7
	3	Not Defined	Error	4, 7
	4	General Sensor Pump1	Error	4, 7
	5	Pump2 Power Supply	Error	4, 7
	6	Pump2 Motor TH	Error	4, 7
	7	Display Card	Error	4, 7
Continue...				

Byte	Bit	Meaning	Class	Device Status Bits Set
...Continue				
19	0	General Sensor Pump2	Error	4, 7
	1	Memory-FL	Error	4, 7
	2	Memory-NVR	Error	4, 7
	3	Characterization	Error	4, 7
	4	PST T-PST	Error	4, 7
	5	PST OV-TR	Error	4, 7
	6	PST T-RET	Error	4, 7
	7	PST RESET	Error	4, 7
20	0	Hyd. Valve Leak	Error	4, 7
	1	Max Start Pump1	Error	4, 7
	2	Max Start Pump2	Error	4, 7
	3	Max Start D-SOV	Error	4, 7
	4	Hand-Pump	Error	4, 7
	5	Max Time Pump1	Error	4, 7
	6	Max Time Pump2	Error	4, 7
	7	PWM Utilization	Error	4, 7
21	0	Not Defined	Error	4, 7
	1	Not Defined	Error	4, 7
	2	Not Defined	Error	4, 7
	3	Not Defined	Error	4, 7
	4	Not Defined	Error	4, 7
	5	Not Defined	Error	4, 7
	6	Not Defined	Error	4, 7
	7	Not Defined	Error	4, 7

Bytes 0-5 are reserved for manufacturer use; they are always set to 0.

“**Maintenance Required**” bit is set to 1 when the date of the next maintenance operation is reached.

“**Device Variable Alert**” bit is set to 1 if one or more variable values is not correctly loaded by the device.

“**Actuator Position**” bit is set to 1 if “Actuator Position” failure is active.

“**Position Demand**” bit is set to 1 if “Position Demand” failure is active.

“**Temperature**” bit is set to 1 if “Temperature” failure is active.

“**Proportional Valve**” bit is set to 1 if “Proportional Valve” failure is active.

“**Power Supply**” bit is set to 1 if “Power Supply” failure is active.

“**Hardware 0**” bit is set to 1 if “Hardware 0” failure is active.

“**SW Error 0**” bit is set to 1 if “SW Error 0” failure is active.

“**HPU Failure**” bit is set to 1 if “HPU Failure” failure is active.

“**Failsafe**” bit is set to 1 if “Failsafe” failure is active.

“**Stayput by SOV**” bit is set to 1 if “Stayput by SOV” failure is active.

“**BUS Control**” bit is set to 1 if “BUS Control” failure is active.

“**High Temperature**” bit is set to 1 if “High Temperature” alarm is active.

“**Low Temperature**” bit is set to 1 if “Low Temperature” alarm is active.

“**Stroke Limit**” bit is set to 1 if “Stroke Limit” alarm is active.

- “**Humidity**” bit is set to 1 if “Humidity” alarm is active.
- “**Fail to Position**” bit is set to 1 if “Fail to Position” alarm is active.
- “**Pump1 Filter**” bit is set to 1 if “Pump1 Filter” alarm is active.
- “**Pump2 Filter**” bit is set to 1 if “Pump2 Filter” alarm is active.
- “**Oil Level**” bit is set to 1 if “Oil Level” alarm is active.
- “**Low Oil Pressure**” bit is set to 1 if “Low Oil Pressure” alarm is active.
- “**Oil Temperature**” bit is set to 1 if “Oil Temperature” alarm is active.
- “**High Oil Pressure**” bit is set to 1 if “High Oil Pressure” alarm is active.
- “**HPU Pressure Transmitter**” bit is set to 1 if “HPU Pressure Transmitter” alarm is active.
- “**HPU Signalling Switch**” bit is set to 1 if “HPU Signalling Switch” alarm is active.
- “**HPU General Sensor**” bit is set to 1 if “HPU General Sensor” alarm is active.
- “**Pump1 Power Supply**” bit is set to 1 if “Pump1 Power Supply” alarm is active.
- “**Pump1 Motor TH**” bit is set to 1 if “Pump1 Motor TH” alarm is active.
- “**General Sensor Pump1**” bit is set to 1 if “General Sensor Pump1” alarm is active.
- “**Pump2 Power Supply**” bit is set to 1 if “Pump2 Power Supply” alarm is active.
- “**Pump2 Motor TH**” bit is set to 1 if “Pump2 Motor TH” alarm is active.
- “**Display Card**” bit is set to 1 if “Display Card” alarm is active.
- “**General Sensor Pump2**” bit is set to 1 if “General Sensor Pump2” alarm is active.
- “**Memory-FL**” bit is set to 1 if “Memory-FL” alarm is active.
- “**Memory-NVR**” bit is set to 1 if “Memory-NVR” alarm is active.
- “**Characterization**” bit is set to 1 if “Characterization” alarm is active.
- “**PST T-PST**” bit is set to 1 if “PST T-PST” alarm is active.
- “**PST OV-TR**” bit is set to 1 if “PST OV-TR” alarm is active.
- “**PST T-RET**” bit is set to 1 if “PST T-RET” alarm is active.
- “**PST RESET**” bit is set to 1 if “PST RESET” alarm is active.
- “**Hyd. Valve Leak**” bit is set to 1 if “Hyd. Valve Leak” alarm is active.
- “**Max Start Pump1**” bit is set to 1 if “Max Start Pump1” alarm is active.
- “**Max Start Pump2**” bit is set to 1 if “Max Start Pump2” alarm is active.
- “**Max Start D-SOV**” bit is set to 1 if “Max Start D-SOV” alarm is active.
- “**Hand Pump**” bit is set to 1 if “Hand Pump” alarm is active.
- “**Max Time Pump1**” bit is set to 1 if “Max Time Pump1” alarm is active.
- “**Max Time Pump2**” bit is set to 1 if “Max Time Pump2” alarm is active.
- “**PWM Utilization**” bit is set to 1 if “PWM Utilization” alarm is active.
- “**Not used**” bits and bytes are always set to 0.

8.2 Common Practice Commands

The following common-practice commands are implemented:

N°	Command Description
42	Perform Device Reset
50	Read Dynamic Variable Assignment
51	Write Dynamic Variable Assignment
54	Read Device Variable Information
59	Write Number of Response Preambles
79	Write Device Variable
95	Read Device Communications Statistics
103	Write Burst Period
104	Write Burst Trigger
105	Read Burst Mode Configuration
107	Write Burst Device Variables
108	Write Burst Mode Command Number
109	Burst Mode Control

8.2.1 Command #42: Perform Device Reset

This command resets the field device. This is equivalent to cycling the power off and then back on to the field device. The field device may not respond to subsequent commands until the reset is complete.

Request Data Bytes

Byte	Format	Description
None		

Response Data Bytes

Byte	Format	Description
None		

Command-Specific Response Codes

Code	Class	Description
0	Success	No Command-Specific Errors
1-5		Undefined
6	Error	Device-Specific Command Error
7-15		Undefined
16	Error	Access Restricted
17-31		Undefined
32	Error	Busy
33-127		Undefined

8.2.2 Command #50: Read Dynamic Variable Assignments

Responds with the Device Variable Numbers that are assigned to the Primary, Secondary, Tertiary and Quaternary Variables.

Unsupported Dynamic Variables returns “250” (Not Used) as the Device Variable assigned.

Request Data Bytes

Byte	Format	Description
None		

Response Data Bytes

Byte	Format	Description
0	Unsigned-8	Device Variable assigned to the Primary Variable
1	Unsigned-8	Device Variable assigned to the Secondary Variable
2	Unsigned-8	Device Variable assigned to the Tertiary Variable
3	Unsigned-8	Device Variable assigned to the Quaternary Variable

Command-Specific Response Codes

Code	Class	Description
0	Success	No Command-Specific Errors
1-5		Undefined
6	Error	Device-Specific Command Error
7-15		Undefined
16	Error	Access Restricted
17-127		Undefined

See Command #51: Write Dynamic Variable Assignments for available Device Variable Codes.

8.2.3 Command #51: Write Dynamic Variable Assignments

Assigns Device Variables to the Primary, Secondary, Tertiary and Quaternary Variables.

Request Data Bytes

Byte	Format	Description
0	Unsigned-8	Device Variable assigned to the Primary Variable
1	Unsigned-8	Device Variable assigned to the Secondary Variable
2	Unsigned-8	Device Variable assigned to the Tertiary Variable
3	Unsigned-8	Device Variable assigned to the Quaternary Variable

Response Data Bytes

Byte	Format	Description
0	Unsigned-8	Device Variable assigned to the Primary Variable
1	Unsigned-8	Device Variable assigned to the Secondary Variable
2	Unsigned-8	Device Variable assigned to the Tertiary Variable
3	Unsigned-8	Device Variable assigned to the Quaternary Variable

Command-Specific Response Codes

Code	Class	Description
0	Success	No Command-Specific Errors
1		Undefined
2	Error	Invalid Selection
3-4		Undefined
5	Error	Too Few Data Bytes Received
6	Error	Device-Specific Command Error
7	Error	In Write Protect Mode
8-15		Undefined
16	Error	Access Restricted
17-31		Undefined
32	Error	Busy
33-127		Undefined

PV Codes available:

Device Variable 1: Position

SV Codes available:

Device Variable 0: Actuator Position (Default SV)

Device Variable 1: Position

Device Variable 2: Demand Source

Device Variable 3: Status Summary

Device Variable 4: Remote Not Available

Device Variable 5: Maintenance Request

Device Variable 6: Status1

Device Variable 7: Status2

Device Variable 8: Failure

Device Variable 9: Alarm1

Device Variable 10: Alarm2

Device Variable 11: Alarm3

Device Variable 12: Oil Pressure
 Device Variable 13: Temperature
 Device Variable 14: Humidity
 Device Variable 19: Pressure1
 Device Variable 20: Pressure2

TV Codes available:

Device Variable 0: Actuator Position
 Device Variable 1: Position
 Device Variable 2: Demand Source
 Device Variable 3: Status Summary (Default TV)
 Device Variable 4: Remote Not Available
 Device Variable 5: Maintenance Request
 Device Variable 6: Status1
 Device Variable 7: Status2
 Device Variable 8: Failure
 Device Variable 9: Alarm1
 Device Variable 10: Alarm2
 Device Variable 11: Alarm3
 Device Variable 12: Oil Pressure
 Device Variable 13: Temperature
 Device Variable 14: Humidity
 Device Variable 19: Pressure1
 Device Variable 20: Pressure2

QV Codes available:

Device Variable 0: Actuator Position
 Device Variable 1: Position
 Device Variable 2: Demand Source
 Device Variable 3: Status Summary
 Device Variable 4: Remote Not Available
 Device Variable 5: Maintenance Request (Default QV)
 Device Variable 6: Status1
 Device Variable 7: Status2
 Device Variable 8: Failure
 Device Variable 9: Alarm1
 Device Variable 10: Alarm2
 Device Variable 11: Alarm3
 Device Variable 12: Oil Pressure
 Device Variable 13: Temperature
 Device Variable 14: Humidity
 Device Variable 19: Pressure1
 Device Variable 20: Pressure2

8.2.4 Command #54: Read Device Variable Information

This command reads the Transducer Serial Number, the Limits, Damping Value and Minimum Span of the selected Device Variable along with the corresponding engineering units.

Request Data Bytes

Byte	Format	Description
0	Unsigned-8	Device Variable Code (see Section 9.1)

Response Data Bytes

Byte	Format	Description
0	Unsigned-8	Device Variable Code (see Section 9.1)
1-3	Unsigned-24	Device Variable Transducer Serial Number
4	Enum	Device Variable Limits/Minimum Span Units Code (see Section 8.4, Table 2)
5-8	Float	Device Variable Upper Transducer Limit
9-12	Float	Device Variable Lower Transducer Limit
13-16	Float	Device Variable Damping Value
17-20	Float	Device Variable Minimum Span
21	Enum	Device Variable Classification (see Section 8.4, Table 21)
22	Enum	Device Variable Family (see Section 8.4, Table 20)
23-26	Time	Update Time Period
27	Bits	Device Variable Properties (see Section 8.4, Table 65)

Command-Specific Response Codes

Code	Class	Description
0	Success	No Command-Specific Errors
1		Undefined
2	Error	Invalid Selection
3-4		Undefined
5	Error	Too Few Data Bytes Received
6	Error	Device-Specific Command Error
7-15		Undefined
16	Error	Access Restricted
17-31		Undefined
32	Error	Busy
33-127		Undefined

8.2.5 Command #59: Write Number of Response Preambles

This command sets the number of asynchronous 0xFF preambles bytes to be sent by a device before the start of a response message. This value may be set to no smaller than 5 and no greater than 20.

Request Data Bytes

Byte	Format	Description
0	Unsigned-8	Number of preambles to be sent with the response message from the Slave to the Master

Response Data Bytes

Byte	Format	Description
0	Unsigned-8	Number of preambles to be sent with the response message from the Slave to the Master

Command-Specific Response Codes

Code	Class	Description
0	Success	No Command-Specific Errors
1-2		Undefined
3	Error	Passed Parameter Too Large
4	Error	Passed Parameter Too Small
5	Error	Too Few Data Bytes Received
6	Error	Device-Specific Command Error
7	Error	In Write Protect Mode
8	Warning	Set To Nearest Possible Value
9-15		Undefined
16	Error	Access Restricted
17-31		Undefined
32	Error	Busy
33-127		Undefined

8.2.6 Command #79: Write Device Variable

This command allows a Device Variable to be set to a fixed value.

Request Data Bytes

Byte	Format	Description
0	Unsigned-8	Device Variable Code (see Section 9.1)
1	Enum	Write Device Variable Command Code (Section 8.4, Table 19)
2	Enum	Units Code (Section 8.4, Table 2)
3-6	Float	Device Variable Value
7	Bits	Device Variable Status (see Section 9.2)

Response Data Bytes

Byte	Format	Description
0	Unsigned-8	Device Variable Code (see Section 9.1)
1	Enum	Write Device Variable Command Code (Section 8.4, Table 19)
2	Enum	Units Code (Section 8.4, Table 2)
3-6	Float	Device Variable Value
7	Bits	Device Variable Status (see Section 9.2)

Command-Specific Response Codes

Code	Class	Description
0	Success	No Command-Specific Errors
1		Undefined
2	Error	Invalid Selection
3-4		Undefined
5	Error	Too Few Data Bytes Received
6	Error	Device-Specific Command Error (Invalid Variable Value)
7	Error	In Write Protect Mode
8	Warning	Device Family status bit not set
9		Undefined
10	Error	Invalid Write Device Variable Command Code
11-13		Undefined
14	Warning	Requested value was returned in command response but Rate-of-Change limit was exceeded. Device Variable tracking to value written at maximum rate allowed.
15		Undefined
16	Error	Access Restricted
17	Error	Invalid Device Variable Index. The Device Variable does not exist in this Field Device.
18	Error	Invalid Units Code
19	Error	Device Variable index not allowed for this command
20-31		Undefined
32	Error	Busy
33	Error	DR Initiated
34	Error	DR Running
35	Error	DR Dead
36	Error	DR Conflict
37-127		Undefined

8.2.7 Command #95: Read Device Communication Statistics

This command returns the field device communication statistics: the number of STX messages received by the device, the number of ACK messages sent by the device and the number of BACK sent by the device.

Request Data Bytes

Byte	Format	Description
None		

Response Data Bytes

Byte	Format	Description
0-1	Unsigned-16	Count of STX messages received by this device
2-3	Unsigned-16	Count of ACK messages sent from this device
4-5	Unsigned-16	Count of BACK messages sent from this device

Command-Specific Response Codes

Code	Class	Description
0	Success	No Command-Specific Errors
1-5		Undefined
6	Error	Device-Specific Command Error
7-127		Undefined

8.2.8 Command #103: Write Burst Period

This command selects the minimum and maximum update period of a burst message. The minimum time must be less than or equal to the maximum time. The update time shall be selected as specified in table below:

< 0.5s Not Allowed	8s
0.5s (default)	16s
1s	32s
2s	60 – 3600s (any value)
4s	> 3600s Not Allowed

The device corrects settings differing from these values and indicates “Update Times Adjusted” in its response message.

Request Data Bytes

Byte	Format	Description
0	Unsigned-8	Burst Message
1-4	Time	Update Period in 1-32 of a millisecond.
5-8	Time	Maximum Update Period in 1/32 of a millisecond.

Response Data Bytes

Byte	Format	Description
0	Unsigned-8	Burst Message
1-4	Time	Update Period in 1-32 of a millisecond.
5-8	Time	Maximum Update Period in 1/32 of a millisecond.

Command-Specific Response Codes

Code	Class	Description
0	Success	No Command-Specific Errors
1-4		Undefined
5	Error	Too Few Data Bytes Received
6	Error	Device-Specific Command Error
7	Error	In Write Protect Mode
8	Warning	Update Times Adjusted
9	Error	Invalid Burst Message
10-15		Undefined
16	Error	Access Restricted
17-31		Undefined
32	Error	Busy (A Delayed Response could not be initiated)
33	Error	Delayed Response Initiated
34	Error	Delayed Response Running
35	Error	Delayed Response Dead
36	Error	Delayed Response Conflict
37-127		Undefined

8.2.9 Command #104: Write Burst Trigger

This command configures the trigger that forces publishing of the Burst Message. Four trigger modes are supported: Continuous (default), Windowed, Rising and Falling.

Continuous Mode: the burst message is sent when the update period is exceeded.

Windowed Mode: the trigger value must be a positive number and is the symmetric window around the last communicated value. The burst message being published after the window was exceeded.

Rising Mode: the burst message is published when the source value exceeds the threshold established by the trigger value.

Falling Mode: the burst message is published when the source value falls below the trigger value.

In all cases, the burst message is triggered when the maximum update time is command 103 is exceeded.

Burst Message Trigger Source

Command	Trigger Source Value
1	PV
2	Loop Current Percent Range
3	PV
9	Device Variable in Slot 0

Request Data Bytes

Byte	Format	Description
0	Unsigned-8	Burst Message
1	Enum	Burst Trigger Mode Selection Code (see Section 8.4, Table 33)
2	Enum	Device Variable Classification for Trigger Level (see Section 8.4, Table 21)
3	Enum	Units Code (see Section 8.4, Table 2)
4-7	Float	Trigger Level

Response Data Bytes

Byte	Format	Description
0	Unsigned-8	Burst Message
1	Enum	Burst Trigger Mode Selection Code (see Section 8.4, Table 33)
2	Enum	Device Variable Classification for Trigger Level (see Section 8.4, Table 21)
3	Enum	Units Code (see Section 8.4, Table 2)
4-7	Float	Trigger Level

Command-Specific Response Codes

Code	Class	Description
0	Success	No Command-Specific Errors
1		Undefined
2	Error	Invalid Selection
3	Error	Passed Parameter Too Large
4	Error	Passed Parameter Too Small
5	Error	Too Few Data Bytes Received
6	Error	Device-Specific Command Error
7	Error	In Write Protect Mode
8		Undefined
9	Error	Invalid Burst Message
10		Undefined
11	Error	Invalid Device Variable Classification
12	Error	Invalid Units Code
13	Error	Invalid Burst Trigger Mode Selection Code
14-15		Undefined
16	Error	Access Restricted
17-31		Undefined
32	Error	Busy (A Delayed Response could not be initiated)
33	Error	Delayed Response Initiated
34	Error	Delayed Response Running
35	Error	Delayed Response Dead
36	Error	Delayed Response Conflict
37-127		Undefined

8.2.10 Command #105: Read Burst Mode Configuration

This command reads the Burst Mode configuration from the field device including: the Burst Mode Control Code, the command to be burst and a list of the Device Variables to be transmitted, the burst minimum and maximum update time and the condition for the maximum update time.

Request Data Bytes

Byte	Format	Description
0	Unsigned-8	Burst Message

Response Data Bytes

Byte	Format	Description
0	Unsigned-8	Burst Mode Control Code (see Section 8.4, Table 9)
1	Unsigned-8	Command Number of the response message to be transmitted
2	Unsigned-8	Device Variable Code assigned to Slot0 (see Section 9.1)
3	Unsigned-8	Device Variable Code assigned to Slot1 (see Section 9.1)
4	Unsigned-8	Device Variable Code assigned to Slot2 (see Section 9.1)
5	Unsigned-8	Device Variable Code assigned to Slot3 (see Section 9.1)
6	Unsigned-8	Device Variable Code assigned to Slot4 (see Section 9.1)
7	Unsigned-8	Device Variable Code assigned to Slot5 (see Section 9.1)
8	Unsigned-8	Device Variable Code assigned to Slot6 (see Section 9.1)
9	Unsigned-8	Device Variable Code assigned to Slot7 (see Section 9.1)
10	Unsigned-8	Burst Message
11	Unsigned-8	Total Number of Burst Messages
12-13	Unsigned-16	Extended Command Number
14-17	Time	Update Time in 1/32 of a millisecond
18-21	Time	Maximum Update Time in 1/32 of a millisecond
22	Enum	Burst Trigger Mode Code (see Section 8.4, Table 33)
23	Enum	Device Variable Classification for Trigger Value (see Section 8.4, Table 21)
24	Enum	Units Code (see Section 8.4, Table 2)
25-28	Float	Trigger Value

Command-Specific Response Codes

Code	Class	Description
0	Success	No Command-Specific Errors
1-5		Undefined
6	Error	Device-Specific Command Error
7-8		Undefined
9	Error	Invalid Burst Message
10-31		Undefined
32	Error	Busy
33-127		Undefined

8.2.11 Command #107: Write Burst Device Variables

This command selects the Device Variables that will be used by a bursting device to be return by a command 9 in Burst Mode.

If the trigger mode isn't Continuous in Command 104 and the trigger source's Device Variable Classification does not match the new Slot 0 Device Variable the new values will be accepted and Response Code "Burst Condition Conflict" will be returned. The field device corrects the classification, unit codes, reset to Trigger Mode Continuous and publishes continuously at the Update Period until it receives another Command 104.

Request Data Bytes

Byte	Format	Description
0	Unsigned-8	Device Variable Code assigned to Slot0 (see Section 9.1)
1	Unsigned-8	Device Variable Code assigned to Slot1 (see Section 9.1)
2	Unsigned-8	Device Variable Code assigned to Slot2 (see Section 9.1)
3	Unsigned-8	Device Variable Code assigned to Slot3 (see Section 9.1)
4	Unsigned-8	Device Variable Code assigned to Slot4 (see Section 9.1)
5	Unsigned-8	Device Variable Code assigned to Slot5 (see Section 9.1)
6	Unsigned-8	Device Variable Code assigned to Slot6 (see Section 9.1)
7	Unsigned-8	Device Variable Code assigned to Slot7 (see Section 9.1)
8	Unsigned-8	Burst Message

Response Data Bytes

Byte	Format	Description
0	Unsigned-8	Device Variable Code assigned to Slot0 (see Section 9.1)
1	Unsigned-8	Device Variable Code assigned to Slot1 (see Section 9.1)
2	Unsigned-8	Device Variable Code assigned to Slot2 (see Section 9.1)
3	Unsigned-8	Device Variable Code assigned to Slot3 (see Section 9.1)
4	Unsigned-8	Device Variable Code assigned to Slot4 (see Section 9.1)
5	Unsigned-8	Device Variable Code assigned to Slot5 (see Section 9.1)
6	Unsigned-8	Device Variable Code assigned to Slot6 (see Section 9.1)
7	Unsigned-8	Device Variable Code assigned to Slot7 (see Section 9.1)
8	Unsigned-8	Burst Message

Command-Specific Response Codes

Code	Class	Description
0	Success	No Command-Specific Errors
1		Undefined
2	Error	Invalid Selection
3-4		Undefined
5	Error	Too Few Data Bytes Received
6	Error	Device-Specific Command Error
7	Error	In Write Protect Mode
8	Warning	Burst Condition Conflict
9	Error	Invalid Burst Message
10-127		Undefined

8.2.12 Command #108: Write Burst Mode Command Number

This command selects the response message that the device transmits while in Burst Mode.

Request Data Bytes

Byte	Format	Description
0-1	Unsigned-16	Command Number of the response message to be transmitted
2	Unsigned-8	Burst Message

Response Data Bytes

Byte	Format	Description
0-1	Unsigned-16	Command Number of the response message to be transmitted
2	Unsigned-8	Burst Message

Command-Specific Response Codes

Code	Class	Description
0	Success	No Command-Specific Errors
1		Undefined
2	Error	Invalid Selection
3-4		Undefined
5	Error	Too Few Data Bytes Received
6	Error	Device-Specific Command Error
7	Error	In Write Protect Mode
8	Warning	Burst Condition Conflict
9	Error	Invalid Burst Message
10-127		Undefined

The following commands can be represented in burst messages:

N°	Command Description
1	Read Primary Variable
2	Read Loop Current and Percent of Range
3	Read Dynamic Variables and Loop Current
9	Read Device Variables with status
48	Read Additional Device Status

8.2.13 Command #109: Burst Mode Control

This command is used to enter and exit the Burst Mode on the field device.

Request Data Bytes

Byte	Format	Description
0	Unsigned-8	Burst Mode Control Code (see Section 8.4, Table 33)
1	Unsigned-8	Burst Message

Response Data Bytes

Byte	Format	Description
0	Unsigned-8	Burst Mode Control Code (see Section 8.4, Table 33)
1	Unsigned-8	Burst Message

Command-Specific Response Codes

Code	Class	Description
0	Success	No Command-Specific Errors
1		Undefined
2	Error	Invalid Selection
3-4		Undefined
5	Error	Too Few Data Bytes Received
6	Error	Device-Specific Command Error
7	Error	In Write Protect Mode
8	Warning	Update Period Increased
9	Error	Insufficient bandwidth
10-15		Undefined
16	Error	Access Restricted
17-31		Undefined
32	Error	Busy (Delayed Response could not be initiated)
33	Error	Delayed Response Initiated
34	Error	Delayed Response Running
35	Error	Delayed Response Dead
36	Error	Delayed Response Conflict
37-127		Undefined

8.3 Device Specific Commands

The following Device-Specific commands are implemented:

N°	Command Description
128	Read Parameter2
129	Write Parameter2
130	Read ParameterE
131	Write ParameterE
132	Read ParameterBE
133	Write ParameterBE
134	Read ParameterF
135	Write ParameterF
136	Read Dates
137	Write Dates
138	Read Times
139	Write Times
140	Read String16
141	Write String16
142	Read String12
143	Read Failure Log
144	Read Alarm Log
145	Read Event Log
146	Read Curve ID and Type
147	Write Curve ID and Type
148	Read Header Curve
149	Read Axis-1 Samples – Part 1
150	Read Axis-1 Samples – Part 2
151	Read Axis-1 Samples – Part 3
152	Read Axis-1 Samples – Part 4
153	Read Axis-2 Samples – Part 1
154	Read Axis-2 Samples – Part 2
155	Read Axis-2 Samples – Part 3
156	Read Axis-2 Samples – Part 4
157	Read Axis-3 Samples – Part 1
158	Read Axis-3 Samples – Part 2
159	Read Axis-3 Samples – Part 3
160	Read Axis-3 Samples – Part 4
161	Read Axis-4 Samples – Part 1
162	Read Axis-4 Samples – Part 2
163	Read Axis-4 Samples – Part 3
164	Read Axis-4 Samples – Part 4
165	Read Axis-5 Samples – Part 1
166	Read Axis-5 Samples – Part 2
167	Read Axis-5 Samples – Part 3
168	Read Axis-5 Samples – Part 4

8.3.1 Command #128: Read Parameter2

This command allows reading the value of one Parameter2.

Request Data Bytes

Byte	Format	Description
0	Enum	Parameter2 Code (see Section 10.1)

Response Data Bytes

Byte	Format	Description
0	Enum	Parameter2 Code (see Section 10.1)
1-2	Unsigned-16	Parameter2 Value
3	Enum	Parameter2 Unit Code (see Section 10.1)

Command-Specific Response Codes

Code	Class	Description
0	Success	No Command-Specific Errors
1		Undefined
2	Error	Invalid Selection
3-4		Undefined
5	Error	Too few data bytes received
6-31		Undefined
32	Error	Device Busy
33-127		Undefined

8.3.2 Command #131: Write Parameter2

This command allows forcing the value of one Parameter2.

Request Data Bytes

Byte	Format	Description
0	Enum	Parameter2 Code (see Section 10.1)
1-2	Unsigned-16	Parameter2 Value

Response Data Bytes

Byte	Format	Description
0	Enum	Parameter2 Code (see Section 10.1)
1-2	Unsigned-16	Parameter2 Value
3	Enum	Parameter2 Unit Code (see Section 10.1)

Command-Specific Response Codes

Code	Class	Description
0	Success	No Command-Specific Errors
1		Undefined
2	Error	Invalid Selection
3-4		Undefined
5	Error	Too few data bytes received
6	Error	Device Specific Command Error
7-31		Undefined
32	Error	Device Busy
33-127		Undefined

If a master tries to write a read only parameter, response code 6 is generated.

If a master tries to write an illegal parameter value, response code 6 is generated.

When this command is executed successfully, the Configuration Change Counter is incremented.

8.3.3 Command #130: Read ParameterE

This command allows reading the value of one ParameterE.

Request Data Bytes

Byte	Format	Description
0	Enum	ParameterE Code (see Section 10.2)

Response Data Bytes

Byte	Format	Description
0	Enum	ParameterE Code (see Section 10.2)
1-2	Enum	ParameterE Value (see Section 10.2.1)

Command-Specific Response Codes

Code	Class	Description
0	Success	No Command-Specific Errors
1		Undefined
2	Error	Invalid Selection
3-4		Undefined
5	Error	Too few data bytes received
6-31		Undefined
32	Error	Device Busy
33-127		Undefined

8.3.4 Command #131: Write ParameterE

This command allows forcing the value of one ParameterE.

Request Data Bytes

Byte	Format	Description
0	Enum	ParameterE Code (see Section 10.2)
1-2	Enum	ParameterE Value (see Section 10.2.1)

Response Data Bytes

Byte	Format	Description
0	Enum	ParameterE Code (see Section 10.2)
1-2	Enum	ParameterE Value (see Section 10.2.1)

Command-Specific Response Codes

Code	Class	Description
0	Success	No Command-Specific Errors
1		Undefined
2	Error	Invalid Selection
3-4		Undefined
5	Error	Too few data bytes received
6	Error	Device Specific Command Error
7-31		Undefined
32	Error	Device Busy
33-127		Undefined

If a master tries to write a read only parameter, response code 6 is generated.

If a master tries to write an illegal parameter value, response code 6 is generated.

When this command is executed successfully, the Configuration Change Counter is incremented.

8.3.1 Command #132: Read ParameterBE

This command allows reading the value of one ParameterBE.

Request Data Bytes

Byte	Format	Description
0	Enum	ParameterBE Code (see Section 10.3)

Response Data Bytes

Byte	Format	Description
0	Enum	ParameterBE Code (see Section 10.3)
1-2	Enum	ParameterBE Value (see Section 10.3.1)

Command-Specific Response Codes

Code	Class	Description
0	Success	No Command-Specific Errors
1		Undefined
2	Error	Invalid Selection
3-4		Undefined
5	Error	Too few data bytes received
6-31		Undefined
32	Error	Device Busy
33-127		Undefined

8.3.2 Command #133: Write ParameterBE

This command allows forcing the value of one ParameterBE.

Request Data Bytes

Byte	Format	Description
0	Enum	ParameterBE Code (see Section 10.3)
1-2	Enum	ParameterBE Value (see Section 10.3.1)

Response Data Bytes

Byte	Format	Description
0	Enum	ParameterBE Code (see Section 10.3)
1-2	Enum	ParameterBE Value (see Section 10.3.1)

Command-Specific Response Codes

Code	Class	Description
0	Success	No Command-Specific Errors
1		Undefined
2	Error	Invalid Selection
3-4		Undefined
5	Error	Too few data bytes received
6	Error	Device Specific Command Error
7-31		Undefined
32	Error	Device Busy
33-127		Undefined

If a master tries to write a read only parameter, response code 6 is generated.

If a master tries to write an illegal parameter value, response code 6 is generated.

When this command is executed successfully, the Configuration Change Counter is incremented.

8.3.3 Command #134: Read ParameterF

This command allows reading the value of one ParameterF.

Request Data Bytes

Byte	Format	Description
0	Enum	ParameterF Code (see Section 10.4)

Response Data Bytes

Byte	Format	Description
0	Enum	ParameterF Code (see Section 10.4)
1-4	Float	ParameterF Value
5	Enum	ParameterF Unit Code (see Section 10.4)

Command-Specific Response Codes

Code	Class	Description
0	Success	No Command-Specific Errors
1		Undefined
2	Error	Invalid Selection
3-4		Undefined
5	Error	Too few data bytes received
6-31		Undefined
32	Error	Device Busy
33-127		Undefined

8.3.4 Command #135: Write ParameterF

This command allows forcing the value of one ParameterF.

Request Data Bytes

Byte	Format	Description
0	Enum	ParameterF Code (see Section 10.4)
1-4	Float	ParameterF Value

Response Data Bytes

Byte	Format	Description
0	Enum	ParameterF Code (see Section 10.4)
1-4	Float	ParameterF Value
5	Enum	ParameterF Unit Code (see Section 10.4)

Command-Specific Response Codes

Code	Class	Description
0	Success	No Command-Specific Errors
1		Undefined
2	Error	Invalid Selection
3-4		Undefined
5	Error	Too few data bytes received
6	Error	Device Specific Command Error
7-31		Undefined
32	Error	Device Busy
33-127		Undefined

If a master tries to write a read only parameter, response code 6 is generated.

If a master tries to write an illegal parameter value, response code 6 is generated.

When this command is executed successfully, the Configuration Change Counter is incremented.

8.3.5 Command #136: Read Dates

This command allows reading the value of one Date parameter.

Request Data Bytes

Byte	Format	Description
0	Enum	Date Code (see Section 10.5)

Response Data Bytes

Byte	Format	Description
0	Enum	Date Code (see Section 10.5)
1	Unsigned-8	Day
2	Unsigned-8	Month
3-4	Unsigned-16	Year

Command-Specific Response Codes

Code	Class	Description
0	Success	No Command-Specific Errors
1		Undefined
2	Error	Invalid Selection
3-4		Undefined
5	Error	Too few data bytes received
6-31		Undefined
32	Error	Device Busy
33-127		Undefined

8.3.6 Command #137: Write Dates

This command allows forcing the value of one Date parameter.

Request Data Bytes

Byte	Format	Description
0	Enum	Date Code (see Section 10.5)
1	Unsigned-8	Day
2	Unsigned-8	Month
3-4	Unsigned-16	Year

Response Data Bytes

Byte	Format	Description
0	Enum	Date Code (see Section 10.5)
1	Unsigned-8	Day
2	Unsigned-8	Month
3-4	Unsigned-16	Year

Command-Specific Response Codes

Code	Class	Description
0	Success	No Command-Specific Errors
1		Undefined
2	Error	Invalid Selection
3-4		Undefined
5	Error	Too few data bytes received
6	Error	Device Specific Command Error
7-31		Undefined
32	Error	Device Busy
33-127		Undefined

If a master tries to write a read only parameter, response code 6 is generated.

If a master tries to write an illegal parameter value, response code 6 is generated.

When this command is executed successfully, the Configuration Change Counter is incremented.

8.3.7 Command #138: Read Times

This command allows reading the value of one Time parameter.

Request Data Bytes

Byte	Format	Description
0	Enum	Time Code (see Section 10.6)

Response Data Bytes

Byte	Format	Description
0	Enum	Time Code (see Section 10.6)
1	Unsigned-8	Hours
2	Unsigned-8	Minutes

Command-Specific Response Codes

Code	Class	Description
0	Success	No Command-Specific Errors
1		Undefined
2	Error	Invalid Selection
3-4		Undefined
5	Error	Too few data bytes received
6-31		Undefined
32	Error	Device Busy
33-127		Undefined

8.3.8 Command #139: Write Times

This command allows forcing the value of one Time parameter.

Request Data Bytes

Byte	Format	Description
0	Enum	Time Code (see Section 10.6)
1	Unsigned-8	Hours
2	Unsigned-8	Minutes

Response Data Bytes

Byte	Format	Description
0	Enum	Time Code (see Section 10.6)
1	Unsigned-8	Hours
2	Unsigned-8	Minutes

Command-Specific Response Codes

Code	Class	Description
0	Success	No Command-Specific Errors
1		Undefined
2	Error	Invalid Selection
3-4		Undefined
5	Error	Too few data bytes received
6	Error	Device Specific Command Error
7-31		Undefined
32	Error	Device Busy
33-127		Undefined

If a master tries to write a read only parameter, response code 6 is generated.

If a master tries to write an illegal parameter value, response code 6 is generated.

When this command is executed successfully, the Configuration Change Counter is incremented.

8.3.9 Command #140: Read String16

This command allows forcing the value of one String16.

Request Data Bytes

Byte	Format	Description
0	Enum	String16 Code (see Section 10.7)

Response Data Bytes

Byte	Format	Description
0	Enum	String16 Code (see Section 10.7)
1-16	ASCII	String16 Value

Command-Specific Response Codes

Code	Class	Description
0	Success	No Command-Specific Errors
1		Undefined
2	Error	Invalid Selection
3-4		Undefined
5	Error	Too few data bytes received
6-31		Undefined
32	Error	Device Busy
33-127		Undefined

When a String16 changes its value, the Configuration Change Counter can be incremented (see section 10.8 for details).

8.3.10 Command #141: Write String16

This command allows forcing the value of one String16.

Request Data Bytes

Byte	Format	Description
0	Enum	String16 Code (see Section 10.7)
1-16	ASCII	String16 Value

Response Data Bytes

Byte	Format	Description
0	Enum	String16 Code (see Section 10.7)
1-16	ASCII	String16 Value

Command-Specific Response Codes

Code	Class	Description
0	Success	No Command-Specific Errors
1		Undefined
2	Error	Invalid Selection
3-4		Undefined
5	Error	Too few data bytes received
6-31		Undefined
32	Error	Device Busy
33-127		Undefined

When this command is executed successfully, the Configuration Change Counter is incremented.

8.3.11 Command #142: Read String12

This command allows reading the value of one String12.

Request Data Bytes

Byte	Format	Description
0	Enum	String12 Code (see Section 10.8)

Response Data Bytes

Byte	Format	Description
0	Enum	String12 Code (see Section 10.8)
1-12	ASCII	String12 Value

Command-Specific Response Codes

Code	Class	Description
0	Success	No Command-Specific Errors
1		Undefined
2	Error	Invalid Selection
3-4		Undefined
5	Error	Too few data bytes received
6-31		Undefined
32	Error	Device Busy
33-127		Undefined

8.3.12 Command #143: Read Failure Log

This command allows reading one Failure Data from the Failure Log List.

Request Data Bytes

Byte	Format	Description
0	Unsigned-8	Failure ID

Response Data Bytes

Byte	Format	Description
0	Unsigned-8	Failure ID
1	Unsigned-8	Failure Date – Day
2	Unsigned-8	Failure Date – Month
3-4	Unsigned-16	Failure Date – Year
5	Unsigned-8	Failure Time – Hours
6	Unsigned-8	Failure Time – Minutes
7	Unsigned-8	Failure Time – Seconds
8	Enum	Failure Code (See section 10.9)

Command-Specific Response Codes

Code	Class	Description
0	Success	No Command-Specific Errors
1		Undefined
2	Error	Invalid Selection
3-4		Undefined
5	Error	Too few data bytes received
6-31		Undefined
32	Error	Device Busy
33-127		Undefined

“Failure ID” is the index of the Failure Log List.

The minimum value is “0”; it indicates the most recent failure.

The maximum value is “31”; it indicates the older failure.

8.3.13 Command #144: Read Alarm Log

This command allows reading one Alarm Data from the Alarm Log List.

Request Data Bytes

Byte	Format	Description
0	Unsigned-8	Alarm ID

Response Data Bytes

Byte	Format	Description
0	Unsigned-8	Alarm ID
1	Unsigned-8	Alarm Date – Day
2	Unsigned-8	Alarm Date – Month
3-4	Unsigned-16	Alarm Date – Year
5	Unsigned-8	Alarm Time – Hours
6	Unsigned-8	Alarm Time – Seconds
7	Unsigned-8	Alarm Time – Seconds
8	Enum	Alarm Code (See section 10.10)

Command-Specific Response Codes

Code	Class	Description
0	Success	No Command-Specific Errors
1		Undefined
2	Error	Invalid Selection
3-4		Undefined
5	Error	Too few data bytes received
6-31		Undefined
32	Error	Device Busy
33-127		Undefined

“Alarm ID” is the index of the Alarm Log List.

The minimum value is “0”; it indicates the most recent alarm.

The maximum value is “31”; it indicates the older alarm.

8.3.14 Command #145: Read Event Log

This command allows reading one Event Data from the Event Log List.

Request Data Bytes

Byte	Format	Description
0	Unsigned-8	Event ID

Response Data Bytes

Byte	Format	Description
0	Unsigned-8	Event ID
1	Unsigned-8	Event Date – Day
2	Unsigned-8	Event Date – Month
3-4	Unsigned-16	Event Date – Year
5	Unsigned-8	Event Time – Hours
6	Unsigned-8	Event Time – Minutes
7	Unsigned-8	Event Time – Seconds
8	Enum	Event Action (See section 10.11)
9	Enum	Event Code (See section 10.12)

Command-Specific Response Codes

Code	Class	Description
0	Success	No Command-Specific Errors
1		Undefined
2	Error	Invalid Selection
3-4		Undefined
5	Error	Too few data bytes received
6-31		Undefined
32	Error	Device Busy
33-127		Undefined

“Event ID” is the index of the Event Log List.

The minimum value is “0”; it indicates the most recent event.

The maximum value is “31”; it indicates the older event.

8.3.15 Command #146: Read CurveID and Type

This command allows reading the CurveID and its Type that can be loaded by Commands #147 - #168.

Request Data Bytes

Byte	Format	Description
------	--------	-------------

Response Data Bytes

Byte	Format	Description
0	Unsigned-8	Curve ID
1	Enum	Curve Type (see Section 10.13)

Command-Specific Response Codes

Code	Class	Description
0	Success	No Command-Specific Errors
1-31		Undefined
32	Error	Device Busy
33-127		Undefined

For each “Curve Type”:

The “Curve ID” minimum value is 0; the maximum value is 5.

“Curve ID” = 0 indicates the Reference Curves.

“Curve ID” = 1 indicates the most recent Curve registered by the actuator.

“Curve ID” = 5 indicates the oldest Curve registered by the actuator.

8.3.16 Command #147: Write CurveID and Type

This command allows forcing the CurveID and its Type that can be loaded by Commands #148 - #168.

Request Data Bytes

Byte	Format	Description
0	Unsigned-8	Curve ID
1	Enum	Curve Type (see Section 10.13)

Response Data Bytes

Byte	Format	Description
0	Unsigned-8	Curve ID
1	Enum	Curve Type (see Section 10.13)

Command-Specific Response Codes

Code	Class	Description
0	Success	No Command-Specific Errors
1		Undefined
2	Error	Invalid Selection
3-4		Undefined
5	Error	Too few data bytes received
6-31		Undefined
32	Error	Device Busy
33-127		Undefined

The “Curve ID” minimum value is 0; the maximum value is 5.

“Curve ID” = 0 indicates the Reference Signature “Curve Type”.

“Curve ID” = 1 indicates the most recent “Curve Type” registered by the actuator.

“Curve ID” = 5 indicates the oldest “Curve Type” registered by the actuator.

8.3.17 Command #148: Read Curve Data Header

This command allows reading the Header Data of the Curve selected by command #147.

Request Data Bytes

Byte	Format	Description
------	--------	-------------

Response Data Bytes

Byte	Format	Description
0	Unsigned-8	Curve ID
1	Unsigned-8	Date – Day
2	Unsigned-8	Date – Month
3-4	Unsigned-16	Date – Year
5	Unsigned-8	Time – Hours
6	Unsigned-8	Time – Minutes
7	Unsigned-8	Time – Seconds
8	Unsigned-8	Axis Number
9-10	Unsigned-16	Samples Number (of each axis)
11-12	Unsigned-16	Sampling Time in milliseconds
13	Enum	Axis-1 Variable Code (see Section 10.14)
14	Enum	Axis-1 Engineering Unit Code (see Section 10.15)
15-18	Float	Axis-1 Min. Value
19-22	Float	Axis-1 Max. Value
23	Enum	Axis-2 Variable Code (see Section 10.14)
24	Enum	Axis-2 Engineering Unit Code (see Section 10.15)
25-28	Float	Axis-2 Min. Value
29-32	Float	Axis-2 Max. Value
33	Enum	Axis-3 Variable code (see Section 10.14)
34	Enum	Axis-3 Engineering Unit Code (see Section 10.15)
35-38	Float	Axis-3 Min. Value
39-42	Float	Axis-3 Max. Value
43	Enum	Axis-4 Variable Code (see Section 10.14)
44	Enum	Axis-4 Engineering Unit Code (see Section 10.15)
45-48	Float	Axis-4 Min. Value
49-52	Float	Axis-4 Max. Value
53	Enum	Axis-5 Variable Code (see Section 10.14)
54	Enum	Axis-5 Engineering Unit Code (see Section 10.15)
55-58	Float	Axis-5 Min. Value
59-62	Float	Axis-5 Max. Value
63	Enum	PST Status
64-67	Float	T-PST (seconds)
68-71	Float	T-RET (seconds)
72-75	Float	OV-TRAV (%)

Command-Specific Response Codes

Code	Class	Description
0	Success	No Command-Specific Errors
1-31		Undefined
32	Error	Device Busy
33-127		Undefined

8.3.18 Command #149: Read Curve Samples Axis-1 – Part 1

This command allows reading the Axis-1 samples (0-49) of the Curve selected by command #147.

Request Data Bytes

Byte	Format	Description
------	--------	-------------

Response Data Bytes

Byte	Format	Description
0-3	Float	Axis-1 Sample #0
4-7	Float	Axis-1 Sample #1
8-11	Float	Axis-1 Sample #2
12-15	Float	Axis-1 Sample #3
16-19	Float	Axis-1 Sample #4
20-23	Float	Axis-1 Sample #5
24-27	Float	Axis-1 Sample #6
28-31	Float	Axis-1 Sample #7
32-35	Float	Axis-1 Sample #8
36-39	Float	Axis-1 Sample #9
40-43	Float	Axis-1 Sample #10
44-47	Float	Axis-1 Sample #11
48-51	Float	Axis-1 Sample #12
52-55	Float	Axis-1 Sample #13
56-59	Float	Axis-1 Sample #14
60-63	Float	Axis-1 Sample #15
64-67	Float	Axis-1 Sample #16
68-71	Float	Axis-1 Sample #17
72-75	Float	Axis-1 Sample #18
76-79	Float	Axis-1 Sample #19
80-83	Float	Axis-1 Sample #20
84-87	Float	Axis-1 Sample #21
88-91	Float	Axis-1 Sample #22
92-95	Float	Axis-1 Sample #23
96-99	Float	Axis-1 Sample #24
100-103	Float	Axis-1 Sample #25
104-107	Float	Axis-1 Sample #26
108-111	Float	Axis-1 Sample #27
112-115	Float	Axis-1 Sample #28
116-119	Float	Axis-1 Sample #29
120-123	Float	Axis-1 Sample #30
124-127	Float	Axis-1 Sample #31
128-131	Float	Axis-1 Sample #32
132-135	Float	Axis-1 Sample #33
136-139	Float	Axis-1 Sample #34
140-143	Float	Axis-1 Sample #35
144-147	Float	Axis-1 Sample #36
148-151	Float	Axis-1 Sample #37
Continue...		

Byte	Format	Description
...Continue		
152-155	Float	Axis-1 Sample #38
156-159	Float	Axis-1 Sample #39
160-163	Float	Axis-1 Sample #40
164-167	Float	Axis-1 Sample #41
168-171	Float	Axis-1 Sample #42
172-175	Float	Axis-1 Sample #43
176-179	Float	Axis-1 Sample #44
180-183	Float	Axis-1 Sample #45
184-187	Float	Axis-1 Sample #46
188-191	Float	Axis-1 Sample #47
192-195	Float	Axis-1 Sample #48
196-199	Float	Axis-1 Sample #49

Command-Specific Response Codes

Code	Class	Description
0	Success	No Command-Specific Errors
1-31		Undefined
32	Error	Device Busy
33-127		Undefined

8.3.19 Command #150: Read Curve Samples Axis-1 – Part 2

This command allows reading the Axis-1 samples (50-99) of the Curve selected by command #147.

Request Data Bytes

Byte	Format	Description
------	--------	-------------

Response Data Bytes

Byte	Format	Description
0-3	Float	Axis-1 Sample #50
4-7	Float	Axis-1 Sample #51
8-11	Float	Axis-1 Sample #52
12-15	Float	Axis-1 Sample #53
16-19	Float	Axis-1 Sample #54
20-23	Float	Axis-1 Sample #55
24-27	Float	Axis-1 Sample #56
28-31	Float	Axis-1 Sample #57
32-35	Float	Axis-1 Sample #58
36-39	Float	Axis-1 Sample #59
40-43	Float	Axis-1 Sample #60
44-47	Float	Axis-1 Sample #61
48-51	Float	Axis-1 Sample #62
52-55	Float	Axis-1 Sample #63
56-59	Float	Axis-1 Sample #64
60-63	Float	Axis-1 Sample #65
64-67	Float	Axis-1 Sample #66
68-71	Float	Axis-1 Sample #67
72-75	Float	Axis-1 Sample #68
76-79	Float	Axis-1 Sample #69
80-83	Float	Axis-1 Sample #70
84-87	Float	Axis-1 Sample #71
88-91	Float	Axis-1 Sample #72
92-95	Float	Axis-1 Sample #73
96-99	Float	Axis-1 Sample #74
100-103	Float	Axis-1 Sample #75
104-107	Float	Axis-1 Sample #76
108-111	Float	Axis-1 Sample #77
112-115	Float	Axis-1 Sample #78
116-119	Float	Axis-1 Sample #79
120-123	Float	Axis-1 Sample #80
124-127	Float	Axis-1 Sample #81
128-131	Float	Axis-1 Sample #82
132-135	Float	Axis-1 Sample #83
136-139	Float	Axis-1 Sample #84
140-143	Float	Axis-1 Sample #85
144-147	Float	Axis-1 Sample #86
148-151	Float	Axis-1 Sample #87
Continue...		

Byte	Format	Description
...Continue		
152-155	Float	Axis-1 Sample #88
156-159	Float	Axis-1 Sample #89
160-163	Float	Axis-1 Sample #90
164-167	Float	Axis-1 Sample #91
168-171	Float	Axis-1 Sample #92
172-175	Float	Axis-1 Sample #93
176-179	Float	Axis-1 Sample #94
180-183	Float	Axis-1 Sample #95
184-187	Float	Axis-1 Sample #96
188-191	Float	Axis-1 Sample #97
192-195	Float	Axis-1 Sample #98
196-199	Float	Axis-1 Sample #99

Command-Specific Response Codes

Code	Class	Description
0	Success	No Command-Specific Errors
1-31		Undefined
32	Error	Device Busy
33-127		Undefined

8.3.20 Command #151: Read Curve Samples Axis-1 – Part 3

This command allows reading the Axis-1 samples (100-149) of the Curve selected by command #147.

Request Data Bytes

Byte	Format	Description
------	--------	-------------

Response Data Bytes

Byte	Format	Description
0-3	Float	Axis-1 Sample #100
4-7	Float	Axis-1 Sample #101
8-11	Float	Axis-1 Sample #102
12-15	Float	Axis-1 Sample #103
16-19	Float	Axis-1 Sample #104
20-23	Float	Axis-1 Sample #105
24-27	Float	Axis-1 Sample #106
28-31	Float	Axis-1 Sample #107
32-35	Float	Axis-1 Sample #108
36-39	Float	Axis-1 Sample #109
40-43	Float	Axis-1 Sample #110
44-47	Float	Axis-1 Sample #111
48-51	Float	Axis-1 Sample #112
52-55	Float	Axis-1 Sample #113
56-59	Float	Axis-1 Sample #114
60-63	Float	Axis-1 Sample #115
64-67	Float	Axis-1 Sample #116
68-71	Float	Axis-1 Sample #117
72-75	Float	Axis-1 Sample #118
76-79	Float	Axis-1 Sample #119
80-83	Float	Axis-1 Sample #120
84-87	Float	Axis-1 Sample #121
88-91	Float	Axis-1 Sample #122
92-95	Float	Axis-1 Sample #123
96-99	Float	Axis-1 Sample #124
100-103	Float	Axis-1 Sample #125
104-107	Float	Axis-1 Sample #126
108-111	Float	Axis-1 Sample #127
112-115	Float	Axis-1 Sample #128
116-119	Float	Axis-1 Sample #129
120-123	Float	Axis-1 Sample #130
124-127	Float	Axis-1 Sample #131
128-131	Float	Axis-1 Sample #132
132-135	Float	Axis-1 Sample #133
136-139	Float	Axis-1 Sample #134
140-143	Float	Axis-1 Sample #135
144-147	Float	Axis-1 Sample #136
148-151	Float	Axis-1 Sample #137
Continue...		

Byte	Format	Description
...Continue		
152-155	Float	Axis-1 Sample #138
156-159	Float	Axis-1 Sample #139
160-163	Float	Axis-1 Sample #140
164-167	Float	Axis-1 Sample #141
168-171	Float	Axis-1 Sample #142
172-175	Float	Axis-1 Sample #143
176-179	Float	Axis-1 Sample #144
180-183	Float	Axis-1 Sample #145
184-187	Float	Axis-1 Sample #146
188-191	Float	Axis-1 Sample #147
192-195	Float	Axis-1 Sample #148
196-199	Float	Axis-1 Sample #149

Command-Specific Response Codes

Code	Class	Description
0	Success	No Command-Specific Errors
1-31		Undefined
32	Error	Device Busy
33-127		Undefined

8.3.21 Command #152: Read Curve Samples Axis-1 – Part 4

This command allows reading the Axis-1 samples (150-200) of the Curve selected by command #147.

Request Data Bytes

Byte	Format	Description
------	--------	-------------

Response Data Bytes

Byte	Format	Description
0-3	Float	Axis-1 Sample #150
4-7	Float	Axis-1 Sample #151
8-11	Float	Axis-1 Sample #152
12-15	Float	Axis-1 Sample #153
16-19	Float	Axis-1 Sample #154
20-23	Float	Axis-1 Sample #155
24-27	Float	Axis-1 Sample #156
28-31	Float	Axis-1 Sample #157
32-35	Float	Axis-1 Sample #158
36-39	Float	Axis-1 Sample #159
40-43	Float	Axis-1 Sample #160
44-47	Float	Axis-1 Sample #161
48-51	Float	Axis-1 Sample #162
52-55	Float	Axis-1 Sample #163
56-59	Float	Axis-1 Sample #164
60-63	Float	Axis-1 Sample #165
64-67	Float	Axis-1 Sample #166
68-71	Float	Axis-1 Sample #167
72-75	Float	Axis-1 Sample #168
76-79	Float	Axis-1 Sample #169
80-83	Float	Axis-1 Sample #170
84-87	Float	Axis-1 Sample #171
88-91	Float	Axis-1 Sample #172
92-95	Float	Axis-1 Sample #173
96-99	Float	Axis-1 Sample #174
100-103	Float	Axis-1 Sample #175
104-107	Float	Axis-1 Sample #176
108-111	Float	Axis-1 Sample #177
112-115	Float	Axis-1 Sample #178
116-119	Float	Axis-1 Sample #179
120-123	Float	Axis-1 Sample #180
124-127	Float	Axis-1 Sample #181
128-131	Float	Axis-1 Sample #182
132-135	Float	Axis-1 Sample #183
136-139	Float	Axis-1 Sample #184
140-143	Float	Axis-1 Sample #185
144-147	Float	Axis-1 Sample #186
148-151	Float	Axis-1 Sample #187
Continue...		

Byte	Format	Description
...Continue		
152-155	Float	Axis-1 Sample #188
156-159	Float	Axis-1 Sample #189
160-163	Float	Axis-1 Sample #190
164-167	Float	Axis-1 Sample #191
168-171	Float	Axis-1 Sample #192
172-175	Float	Axis-1 Sample #193
176-179	Float	Axis-1 Sample #194
180-183	Float	Axis-1 Sample #195
184-187	Float	Axis-1 Sample #196
188-191	Float	Axis-1 Sample #197
192-195	Float	Axis-1 Sample #198
196-199	Float	Axis-1 Sample #199
200-203	Float	Axis-1 Sample #200

Command-Specific Response Codes

Code	Class	Description
0	Success	No Command-Specific Errors
1-31		Undefined
32	Error	Device Busy
33-127		Undefined

8.3.22 Command #153: Read Curve Samples Axis-2 – Part 1

This command allows reading the Axis-2 samples (0-49) of the Curve selected by command #147.

Request Data Bytes

Byte	Format	Description
------	--------	-------------

Response Data Bytes

Byte	Format	Description
0-3	Float	Axis-2 Sample #0
4-7	Float	Axis-2 Sample #1
8-11	Float	Axis-2 Sample #2
12-15	Float	Axis-2 Sample #3
16-19	Float	Axis-2 Sample #4
20-23	Float	Axis-2 Sample #5
24-27	Float	Axis-2 Sample #6
28-31	Float	Axis-2 Sample #7
32-35	Float	Axis-2 Sample #8
36-39	Float	Axis-2 Sample #9
40-43	Float	Axis-2 Sample #10
44-47	Float	Axis-2 Sample #11
48-51	Float	Axis-2 Sample #12
52-55	Float	Axis-2 Sample #13
56-59	Float	Axis-2 Sample #14
60-63	Float	Axis-2 Sample #15
64-67	Float	Axis-2 Sample #16
68-71	Float	Axis-2 Sample #17
72-75	Float	Axis-2 Sample #18
76-79	Float	Axis-2 Sample #19
80-83	Float	Axis-2 Sample #20
84-87	Float	Axis-2 Sample #21
88-91	Float	Axis-2 Sample #22
92-95	Float	Axis-2 Sample #23
96-99	Float	Axis-2 Sample #24
100-103	Float	Axis-2 Sample #25
104-107	Float	Axis-2 Sample #26
108-111	Float	Axis-2 Sample #27
112-115	Float	Axis-2 Sample #28
116-119	Float	Axis-2 Sample #29
120-123	Float	Axis-2 Sample #30
124-127	Float	Axis-2 Sample #31
128-131	Float	Axis-2 Sample #32
132-135	Float	Axis-2 Sample #33
136-139	Float	Axis-2 Sample #34
140-143	Float	Axis-2 Sample #35
144-147	Float	Axis-2 Sample #36
148-151	Float	Axis-2 Sample #37
Continue...		

Byte	Format	Description
...Continue		
152-155	Float	Axis-2 Sample #38
156-159	Float	Axis-2 Sample #39
160-163	Float	Axis-2 Sample #40
164-167	Float	Axis-2 Sample #41
168-171	Float	Axis-2 Sample #42
172-175	Float	Axis-2 Sample #43
176-179	Float	Axis-2 Sample #44
180-183	Float	Axis-2 Sample #45
184-187	Float	Axis-2 Sample #46
188-191	Float	Axis-2 Sample #47
192-195	Float	Axis-2 Sample #48
196-199	Float	Axis-2 Sample #49

Command-Specific Response Codes

Code	Class	Description
0	Success	No Command-Specific Errors
1-31		Undefined
32	Error	Device Busy
33-127		Undefined

8.3.23 Command #154: Read Curve Samples Axis-2 – Part 2

This command allows reading the Axis-2 samples (50-99) of the Curve selected by command #147.

Request Data Bytes

Byte	Format	Description
------	--------	-------------

Response Data Bytes

Byte	Format	Description
0-3	Float	Axis-2 Sample #50
4-7	Float	Axis-2 Sample #51
8-11	Float	Axis-2 Sample #52
12-15	Float	Axis-2 Sample #53
16-19	Float	Axis-2 Sample #54
20-23	Float	Axis-2 Sample #55
24-27	Float	Axis-2 Sample #56
28-31	Float	Axis-2 Sample #57
32-35	Float	Axis-2 Sample #58
36-39	Float	Axis-2 Sample #59
40-43	Float	Axis-2 Sample #60
44-47	Float	Axis-2 Sample #61
48-51	Float	Axis-2 Sample #62
52-55	Float	Axis-2 Sample #63
56-59	Float	Axis-2 Sample #64
60-63	Float	Axis-2 Sample #65
64-67	Float	Axis-2 Sample #66
68-71	Float	Axis-2 Sample #67
72-75	Float	Axis-2 Sample #68
76-79	Float	Axis-2 Sample #69
80-83	Float	Axis-2 Sample #70
84-87	Float	Axis-2 Sample #71
88-91	Float	Axis-2 Sample #72
92-95	Float	Axis-2 Sample #73
96-99	Float	Axis-2 Sample #74
100-103	Float	Axis-2 Sample #75
104-107	Float	Axis-2 Sample #76
108-111	Float	Axis-2 Sample #77
112-115	Float	Axis-2 Sample #78
116-119	Float	Axis-2 Sample #79
120-123	Float	Axis-2 Sample #80
124-127	Float	Axis-2 Sample #81
128-131	Float	Axis-2 Sample #82
132-135	Float	Axis-2 Sample #83
136-139	Float	Axis-2 Sample #84
140-143	Float	Axis-2 Sample #85
144-147	Float	Axis-2 Sample #86
148-151	Float	Axis-2 Sample #87
Continue...		

Byte	Format	Description
...Continue		
152-155	Float	Axis-2 Sample #88
156-159	Float	Axis-2 Sample #89
160-163	Float	Axis-2 Sample #90
164-167	Float	Axis-2 Sample #91
168-171	Float	Axis-2 Sample #92
172-175	Float	Axis-2 Sample #93
176-179	Float	Axis-2 Sample #94
180-183	Float	Axis-2 Sample #95
184-187	Float	Axis-2 Sample #96
188-191	Float	Axis-2 Sample #97
192-195	Float	Axis-2 Sample #98
196-199	Float	Axis-2 Sample #99

Command-Specific Response Codes

Code	Class	Description
0	Success	No Command-Specific Errors
1-31		Undefined
32	Error	Device Busy
33-127		Undefined

8.3.24 Command #155: Read Curve Samples Axis-2 – Part 3

This command allows reading the Axis-2 samples (100-149) of the Curve selected by command #147.

Request Data Bytes

Byte	Format	Description
------	--------	-------------

Response Data Bytes

Byte	Format	Description
0-3	Float	Axis-2 Sample #100
4-7	Float	Axis-2 Sample #101
8-11	Float	Axis-2 Sample #102
12-15	Float	Axis-2 Sample #103
16-19	Float	Axis-2 Sample #104
20-23	Float	Axis-2 Sample #105
24-27	Float	Axis-2 Sample #106
28-31	Float	Axis-2 Sample #107
32-35	Float	Axis-2 Sample #108
36-39	Float	Axis-2 Sample #109
40-43	Float	Axis-2 Sample #110
44-47	Float	Axis-2 Sample #111
48-51	Float	Axis-2 Sample #112
52-55	Float	Axis-2 Sample #113
56-59	Float	Axis-2 Sample #114
60-63	Float	Axis-2 Sample #115
64-67	Float	Axis-2 Sample #116
68-71	Float	Axis-2 Sample #117
72-75	Float	Axis-2 Sample #118
76-79	Float	Axis-2 Sample #119
80-83	Float	Axis-2 Sample #120
84-87	Float	Axis-2 Sample #121
88-91	Float	Axis-2 Sample #122
92-95	Float	Axis-2 Sample #123
96-99	Float	Axis-2 Sample #124
100-103	Float	Axis-2 Sample #125
104-107	Float	Axis-2 Sample #126
108-111	Float	Axis-2 Sample #127
112-115	Float	Axis-2 Sample #128
116-119	Float	Axis-2 Sample #129
120-123	Float	Axis-2 Sample #130
124-127	Float	Axis-2 Sample #131
128-131	Float	Axis-2 Sample #132
132-135	Float	Axis-2 Sample #133
136-139	Float	Axis-2 Sample #134
140-143	Float	Axis-2 Sample #135
144-147	Float	Axis-2 Sample #136
148-151	Float	Axis-2 Sample #137
Continue...		

Byte	Format	Description
...Continue		
152-155	Float	Axis-2 Sample #138
156-159	Float	Axis-2 Sample #139
160-163	Float	Axis-2 Sample #140
164-167	Float	Axis-2 Sample #141
168-171	Float	Axis-2 Sample #142
172-175	Float	Axis-2 Sample #143
176-179	Float	Axis-2 Sample #144
180-183	Float	Axis-2 Sample #145
184-187	Float	Axis-2 Sample #146
188-191	Float	Axis-2 Sample #147
192-195	Float	Axis-2 Sample #148
196-199	Float	Axis-2 Sample #149

Command-Specific Response Codes

Code	Class	Description
0	Success	No Command-Specific Errors
1-31		Undefined
32	Error	Device Busy
33-127		Undefined

8.3.25 Command #156: Read Curve Samples Axis-2 – Part 4

This command allows reading the Axis-2 samples (150-200) of the Curve selected by command #147.

Request Data Bytes

Byte	Format	Description
------	--------	-------------

Response Data Bytes

Byte	Format	Description
0-3	Float	Axis-2 Sample #150
4-7	Float	Axis-2 Sample #151
8-11	Float	Axis-2 Sample #152
12-15	Float	Axis-2 Sample #153
16-19	Float	Axis-2 Sample #154
20-23	Float	Axis-2 Sample #155
24-27	Float	Axis-2 Sample #156
28-31	Float	Axis-2 Sample #157
32-35	Float	Axis-2 Sample #158
36-39	Float	Axis-2 Sample #159
40-43	Float	Axis-2 Sample #160
44-47	Float	Axis-2 Sample #161
48-51	Float	Axis-2 Sample #162
52-55	Float	Axis-2 Sample #163
56-59	Float	Axis-2 Sample #164
60-63	Float	Axis-2 Sample #165
64-67	Float	Axis-2 Sample #166
68-71	Float	Axis-2 Sample #167
72-75	Float	Axis-2 Sample #168
76-79	Float	Axis-2 Sample #169
80-83	Float	Axis-2 Sample #170
84-87	Float	Axis-2 Sample #171
88-91	Float	Axis-2 Sample #172
92-95	Float	Axis-2 Sample #173
96-99	Float	Axis-2 Sample #174
100-103	Float	Axis-2 Sample #175
104-107	Float	Axis-2 Sample #176
108-111	Float	Axis-2 Sample #177
112-115	Float	Axis-2 Sample #178
116-119	Float	Axis-2 Sample #179
120-123	Float	Axis-2 Sample #180
124-127	Float	Axis-2 Sample #181
128-131	Float	Axis-2 Sample #182
132-135	Float	Axis-2 Sample #183
136-139	Float	Axis-2 Sample #184
140-143	Float	Axis-2 Sample #185
144-147	Float	Axis-2 Sample #186
148-151	Float	Axis-2 Sample #187
Continue...		

Byte	Format	Description
...Continue		
152-155	Float	Axis-2 Sample #188
156-159	Float	Axis-2 Sample #189
160-163	Float	Axis-2 Sample #190
164-167	Float	Axis-2 Sample #191
168-171	Float	Axis-2 Sample #192
172-175	Float	Axis-2 Sample #193
176-179	Float	Axis-2 Sample #194
180-183	Float	Axis-2 Sample #195
184-187	Float	Axis-2 Sample #196
188-191	Float	Axis-2 Sample #197
192-195	Float	Axis-2 Sample #198
196-199	Float	Axis-2 Sample #199
200-203	Float	Axis-2 Sample #200

Command-Specific Response Codes

Code	Class	Description
0	Success	No Command-Specific Errors
1-31		Undefined
32	Error	Device Busy
33-127		Undefined

8.3.26 Command #157: Read Curve Samples Axis-3 – Part 1

This command allows reading the Axis-3 samples (0-49) of the Curve selected by command #147.

Request Data Bytes

Byte	Format	Description
------	--------	-------------

Response Data Bytes

Byte	Format	Description
0-3	Float	Axis-3 Sample #0
4-7	Float	Axis-3 Sample #1
8-11	Float	Axis-3 Sample #2
12-15	Float	Axis-3 Sample #3
16-19	Float	Axis-3 Sample #4
20-23	Float	Axis-3 Sample #5
24-27	Float	Axis-3 Sample #6
28-31	Float	Axis-3 Sample #7
32-35	Float	Axis-3 Sample #8
36-39	Float	Axis-3 Sample #9
40-43	Float	Axis-3 Sample #10
44-47	Float	Axis-3 Sample #11
48-51	Float	Axis-3 Sample #12
52-55	Float	Axis-3 Sample #13
56-59	Float	Axis-3 Sample #14
60-63	Float	Axis-3 Sample #15
64-67	Float	Axis-3 Sample #16
68-71	Float	Axis-3 Sample #17
72-75	Float	Axis-3 Sample #18
76-79	Float	Axis-3 Sample #19
80-83	Float	Axis-3 Sample #20
84-87	Float	Axis-3 Sample #21
88-91	Float	Axis-3 Sample #22
92-95	Float	Axis-3 Sample #23
96-99	Float	Axis-3 Sample #24
100-103	Float	Axis-3 Sample #25
104-107	Float	Axis-3 Sample #26
108-111	Float	Axis-3 Sample #27
112-115	Float	Axis-3 Sample #28
116-119	Float	Axis-3 Sample #29
120-123	Float	Axis-3 Sample #30
124-127	Float	Axis-3 Sample #31
128-131	Float	Axis-3 Sample #32
132-135	Float	Axis-3 Sample #33
136-139	Float	Axis-3 Sample #34
140-143	Float	Axis-3 Sample #35
144-147	Float	Axis-3 Sample #36
148-151	Float	Axis-3 Sample #37
Continue...		

Byte	Format	Description
...Continue		
152-155	Float	Axis-3 Sample #38
156-159	Float	Axis-3 Sample #39
160-163	Float	Axis-3 Sample #40
164-167	Float	Axis-3 Sample #41
168-171	Float	Axis-3 Sample #42
172-175	Float	Axis-3 Sample #43
176-179	Float	Axis-3 Sample #44
180-183	Float	Axis-3 Sample #45
184-187	Float	Axis-3 Sample #46
188-191	Float	Axis-3 Sample #47
192-195	Float	Axis-3 Sample #48
196-199	Float	Axis-3 Sample #49

Command-Specific Response Codes

Code	Class	Description
0	Success	No Command-Specific Errors
1-31		Undefined
32	Error	Device Busy
33-127		Undefined

8.3.27 Command #158: Read Curve Samples Axis-3 – Part 2

This command allows reading the Axis-3 samples (50-99) of the Curve selected by command #147.

Request Data Bytes

Byte	Format	Description
------	--------	-------------

Response Data Bytes

Byte	Format	Description
0-3	Float	Axis-3 Sample #50
4-7	Float	Axis-3 Sample #51
8-11	Float	Axis-3 Sample #52
12-15	Float	Axis-3 Sample #53
16-19	Float	Axis-3 Sample #54
20-23	Float	Axis-3 Sample #55
24-27	Float	Axis-3 Sample #56
28-31	Float	Axis-3 Sample #57
32-35	Float	Axis-3 Sample #58
36-39	Float	Axis-3 Sample #59
40-43	Float	Axis-3 Sample #60
44-47	Float	Axis-3 Sample #61
48-51	Float	Axis-3 Sample #62
52-55	Float	Axis-3 Sample #63
56-59	Float	Axis-3 Sample #64
60-63	Float	Axis-3 Sample #65
64-67	Float	Axis-3 Sample #66
68-71	Float	Axis-3 Sample #67
72-75	Float	Axis-3 Sample #68
76-79	Float	Axis-3 Sample #69
80-83	Float	Axis-3 Sample #70
84-87	Float	Axis-3 Sample #71
88-91	Float	Axis-3 Sample #72
92-95	Float	Axis-3 Sample #73
96-99	Float	Axis-3 Sample #74
100-103	Float	Axis-3 Sample #75
104-107	Float	Axis-3 Sample #76
108-111	Float	Axis-3 Sample #77
112-115	Float	Axis-3 Sample #78
116-119	Float	Axis-3 Sample #79
120-123	Float	Axis-3 Sample #80
124-127	Float	Axis-3 Sample #81
128-131	Float	Axis-3 Sample #82
132-135	Float	Axis-3 Sample #83
136-139	Float	Axis-3 Sample #84
140-143	Float	Axis-3 Sample #85
144-147	Float	Axis-3 Sample #86
148-151	Float	Axis-3 Sample #87
Continue...		

Byte	Format	Description
...Continue		
152-155	Float	Axis-3 Sample #88
156-159	Float	Axis-3 Sample #89
160-163	Float	Axis-3 Sample #90
164-167	Float	Axis-3 Sample #91
168-171	Float	Axis-3 Sample #92
172-175	Float	Axis-3 Sample #93
176-179	Float	Axis-3 Sample #94
180-183	Float	Axis-3 Sample #95
184-187	Float	Axis-3 Sample #96
188-191	Float	Axis-3 Sample #97
192-195	Float	Axis-3 Sample #98
196-199	Float	Axis-3 Sample #99

Command-Specific Response Codes

Code	Class	Description
0	Success	No Command-Specific Errors
1-31		Undefined
32	Error	Device Busy
33-127		Undefined

8.3.28 Command #159: Read Curve Samples Axis-3 – Part 3

This command allows reading the Axis-3 samples (100-149) of the Curve selected by command #152.

Request Data Bytes

Byte	Format	Description
------	--------	-------------

Response Data Bytes

Byte	Format	Description
0-3	Float	Axis-3 Sample #100
4-7	Float	Axis-3 Sample #101
8-11	Float	Axis-3 Sample #102
12-15	Float	Axis-3 Sample #103
16-19	Float	Axis-3 Sample #104
20-23	Float	Axis-3 Sample #105
24-27	Float	Axis-3 Sample #106
28-31	Float	Axis-3 Sample #107
32-35	Float	Axis-3 Sample #108
36-39	Float	Axis-3 Sample #109
40-43	Float	Axis-3 Sample #110
44-47	Float	Axis-3 Sample #111
48-51	Float	Axis-3 Sample #112
52-55	Float	Axis-3 Sample #113
56-59	Float	Axis-3 Sample #114
60-63	Float	Axis-3 Sample #115
64-67	Float	Axis-3 Sample #116
68-71	Float	Axis-3 Sample #117
72-75	Float	Axis-3 Sample #118
76-79	Float	Axis-3 Sample #119
80-83	Float	Axis-3 Sample #120
84-87	Float	Axis-3 Sample #121
88-91	Float	Axis-3 Sample #122
92-95	Float	Axis-3 Sample #123
96-99	Float	Axis-3 Sample #124
100-103	Float	Axis-3 Sample #125
104-107	Float	Axis-3 Sample #126
108-111	Float	Axis-3 Sample #127
112-115	Float	Axis-3 Sample #128
116-119	Float	Axis-3 Sample #129
120-123	Float	Axis-3 Sample #130
124-127	Float	Axis-3 Sample #131
128-131	Float	Axis-3 Sample #132
132-135	Float	Axis-3 Sample #133
136-139	Float	Axis-3 Sample #134
140-143	Float	Axis-3 Sample #135
144-147	Float	Axis-3 Sample #136
148-151	Float	Axis-3 Sample #137
Continue...		

Byte	Format	Description
...Continue		
152-155	Float	Axis-3 Sample #138
156-159	Float	Axis-3 Sample #139
160-163	Float	Axis-3 Sample #140
164-167	Float	Axis-3 Sample #141
168-171	Float	Axis-3 Sample #142
172-175	Float	Axis-3 Sample #143
176-179	Float	Axis-3 Sample #144
180-183	Float	Axis-3 Sample #145
184-187	Float	Axis-3 Sample #146
188-191	Float	Axis-3 Sample #147
192-195	Float	Axis-3 Sample #148
196-199	Float	Axis-3 Sample #149

Command-Specific Response Codes

Code	Class	Description
0	Success	No Command-Specific Errors
1-31		Undefined
32	Error	Device Busy
33-127		Undefined

8.3.29 Command #160: Read Curve Samples Axis-3 – Part 4

This command allows reading the Axis-3 samples (150-200) of the Curve selected by command #147.

Request Data Bytes

Byte	Format	Description
------	--------	-------------

Response Data Bytes

Byte	Format	Description
0-3	Float	Axis-3 Sample #150
4-7	Float	Axis-3 Sample #151
8-11	Float	Axis-3 Sample #152
12-15	Float	Axis-3 Sample #153
16-19	Float	Axis-3 Sample #154
20-23	Float	Axis-3 Sample #155
24-27	Float	Axis-3 Sample #156
28-31	Float	Axis-3 Sample #157
32-35	Float	Axis-3 Sample #158
36-39	Float	Axis-3 Sample #159
40-43	Float	Axis-3 Sample #160
44-47	Float	Axis-3 Sample #161
48-51	Float	Axis-3 Sample #162
52-55	Float	Axis-3 Sample #163
56-59	Float	Axis-3 Sample #164
60-63	Float	Axis-3 Sample #165
64-67	Float	Axis-3 Sample #166
68-71	Float	Axis-3 Sample #167
72-75	Float	Axis-3 Sample #168
76-79	Float	Axis-3 Sample #169
80-83	Float	Axis-3 Sample #170
84-87	Float	Axis-3 Sample #171
88-91	Float	Axis-3 Sample #172
92-95	Float	Axis-3 Sample #173
96-99	Float	Axis-3 Sample #174
100-103	Float	Axis-3 Sample #175
104-107	Float	Axis-3 Sample #176
108-111	Float	Axis-3 Sample #177
112-115	Float	Axis-3 Sample #178
116-119	Float	Axis-3 Sample #179
120-123	Float	Axis-3 Sample #180
124-127	Float	Axis-3 Sample #181
128-131	Float	Axis-3 Sample #182
132-135	Float	Axis-3 Sample #183
136-139	Float	Axis-3 Sample #184
140-143	Float	Axis-3 Sample #185
144-147	Float	Axis-3 Sample #186
148-151	Float	Axis-3 Sample #187
Continue...		

Byte	Format	Description
...Continue		
152-155	Float	Axis-3 Sample #188
156-159	Float	Axis-3 Sample #189
160-163	Float	Axis-3 Sample #190
164-167	Float	Axis-3 Sample #191
168-171	Float	Axis-3 Sample #192
172-175	Float	Axis-3 Sample #193
176-179	Float	Axis-3 Sample #194
180-183	Float	Axis-3 Sample #195
184-187	Float	Axis-3 Sample #196
188-191	Float	Axis-3 Sample #197
192-195	Float	Axis-3 Sample #198
196-199	Float	Axis-3 Sample #199
200-203	Float	Axis-3 Sample #200

Command-Specific Response Codes

Code	Class	Description
0	Success	No Command-Specific Errors
1-31		Undefined
32	Error	Device Busy
33-127		Undefined

8.3.30 Command #161: Read Curve Samples Axis-4 – Part 1

This command allows reading the Axis-4 samples (0-49) of the Curve selected by command #147.

Request Data Bytes

Byte	Format	Description
------	--------	-------------

Response Data Bytes

Byte	Format	Description
0-3	Float	Axis-4 Sample #0
4-7	Float	Axis-4 Sample #1
8-11	Float	Axis-4 Sample #2
12-15	Float	Axis-4 Sample #3
16-19	Float	Axis-4 Sample #4
20-23	Float	Axis-4 Sample #5
24-27	Float	Axis-4 Sample #6
28-31	Float	Axis-4 Sample #7
32-35	Float	Axis-4 Sample #8
36-39	Float	Axis-4 Sample #9
40-43	Float	Axis-4 Sample #10
44-47	Float	Axis-4 Sample #11
48-51	Float	Axis-4 Sample #12
52-55	Float	Axis-4 Sample #13
56-59	Float	Axis-4 Sample #14
60-63	Float	Axis-4 Sample #15
64-67	Float	Axis-4 Sample #16
68-71	Float	Axis-4 Sample #17
72-75	Float	Axis-4 Sample #18
76-79	Float	Axis-4 Sample #19
80-83	Float	Axis-4 Sample #20
84-87	Float	Axis-4 Sample #21
88-91	Float	Axis-4 Sample #22
92-95	Float	Axis-4 Sample #23
96-99	Float	Axis-4 Sample #24
100-103	Float	Axis-4 Sample #25
104-107	Float	Axis-4 Sample #26
108-111	Float	Axis-4 Sample #27
112-115	Float	Axis-4 Sample #28
116-119	Float	Axis-4 Sample #29
120-123	Float	Axis-4 Sample #30
124-127	Float	Axis-4 Sample #31
128-131	Float	Axis-4 Sample #32
132-135	Float	Axis-4 Sample #33
136-139	Float	Axis-4 Sample #34
140-143	Float	Axis-4 Sample #35
144-147	Float	Axis-4 Sample #36
148-151	Float	Axis-4 Sample #37
152-155	Float	Axis-4 Sample #38
Continue...		

Byte	Format	Description
...Continue		
156-159	Float	Axis-4 Sample #39
160-163	Float	Axis-4 Sample #40
164-167	Float	Axis-4 Sample #41
168-171	Float	Axis-4 Sample #42
172-175	Float	Axis-4 Sample #43
176-179	Float	Axis-4 Sample #44
180-183	Float	Axis-4 Sample #45
184-187	Float	Axis-4 Sample #46
188-191	Float	Axis-4 Sample #47
192-195	Float	Axis-4 Sample #48
196-199	Float	Axis-4 Sample #49

Command-Specific Response Codes

Code	Class	Description
0	Success	No Command-Specific Errors
1-31		Undefined
32	Error	Device Busy
33-127		Undefined

8.3.31 Command #162: Read Curve Samples Axis-4 – Part 2

This command allows reading the Axis-4 samples (50-99) of the Curve selected by command #147.

Request Data Bytes

Byte	Format	Description
------	--------	-------------

Response Data Bytes

Byte	Format	Description
0-3	Float	Axis-4 Sample #50
4-7	Float	Axis-4 Sample #51
8-11	Float	Axis-4 Sample #52
12-15	Float	Axis-4 Sample #53
16-19	Float	Axis-4 Sample #54
20-23	Float	Axis-4 Sample #55
24-27	Float	Axis-4 Sample #56
28-31	Float	Axis-4 Sample #57
32-35	Float	Axis-4 Sample #58
36-39	Float	Axis-4 Sample #59
40-43	Float	Axis-4 Sample #60
44-47	Float	Axis-4 Sample #61
48-51	Float	Axis-4 Sample #62
52-55	Float	Axis-4 Sample #63
56-59	Float	Axis-4 Sample #64
60-63	Float	Axis-4 Sample #65
64-67	Float	Axis-4 Sample #66
68-71	Float	Axis-4 Sample #67
72-75	Float	Axis-4 Sample #68
76-79	Float	Axis-4 Sample #69
80-83	Float	Axis-4 Sample #70
84-87	Float	Axis-4 Sample #71
88-91	Float	Axis-4 Sample #72
92-95	Float	Axis-4 Sample #73
96-99	Float	Axis-4 Sample #74
100-103	Float	Axis-4 Sample #75
104-107	Float	Axis-4 Sample #76
108-111	Float	Axis-4 Sample #77
112-115	Float	Axis-4 Sample #78
116-119	Float	Axis-4 Sample #79
120-123	Float	Axis-4 Sample #80
124-127	Float	Axis-4 Sample #81
128-131	Float	Axis-4 Sample #82
132-135	Float	Axis-4 Sample #83
136-139	Float	Axis-4 Sample #84
140-143	Float	Axis-4 Sample #85
144-147	Float	Axis-4 Sample #86
148-151	Float	Axis-4 Sample #87
Continue...		

Byte	Format	Description
...Continue		
152-155	Float	Axis-4 Sample #88
156-159	Float	Axis-4 Sample #89
160-163	Float	Axis-4 Sample #90
164-167	Float	Axis-4 Sample #91
168-171	Float	Axis-4 Sample #92
172-175	Float	Axis-4 Sample #93
176-179	Float	Axis-4 Sample #94
180-183	Float	Axis-4 Sample #95
184-187	Float	Axis-4 Sample #96
188-191	Float	Axis-4 Sample #97
192-195	Float	Axis-4 Sample #98
196-199	Float	Axis-4 Sample #99

Command-Specific Response Codes

Code	Class	Description
0	Success	No Command-Specific Errors
1-31		Undefined
32	Error	Device Busy
33-127		Undefined

8.3.32 Command #163: Read Curve Samples Axis-4 – Part 3

This command allows reading the Axis-4 samples (100-149) of the Curve selected by command #147.

Request Data Bytes

Byte	Format	Description
------	--------	-------------

Response Data Bytes

Byte	Format	Description
0-3	Float	Axis-4 Sample #100
4-7	Float	Axis-4 Sample #101
8-11	Float	Axis-4 Sample #102
12-15	Float	Axis-4 Sample #103
16-19	Float	Axis-4 Sample #104
20-23	Float	Axis-4 Sample #105
24-27	Float	Axis-4 Sample #106
28-31	Float	Axis-4 Sample #107
32-35	Float	Axis-4 Sample #108
36-39	Float	Axis-4 Sample #109
40-43	Float	Axis-4 Sample #110
44-47	Float	Axis-4 Sample #111
48-51	Float	Axis-4 Sample #112
52-55	Float	Axis-4 Sample #113
56-59	Float	Axis-4 Sample #114
60-63	Float	Axis-4 Sample #115
64-67	Float	Axis-4 Sample #116
68-71	Float	Axis-4 Sample #117
72-75	Float	Axis-4 Sample #118
76-79	Float	Axis-4 Sample #119
80-83	Float	Axis-4 Sample #120
84-87	Float	Axis-4 Sample #121
88-91	Float	Axis-4 Sample #122
92-95	Float	Axis-4 Sample #123
96-99	Float	Axis-4 Sample #124
100-103	Float	Axis-4 Sample #125
104-107	Float	Axis-4 Sample #126
108-111	Float	Axis-4 Sample #127
112-115	Float	Axis-4 Sample #128
116-119	Float	Axis-4 Sample #129
120-123	Float	Axis-4 Sample #130
124-127	Float	Axis-4 Sample #131
128-131	Float	Axis-4 Sample #132
132-135	Float	Axis-4 Sample #133
136-139	Float	Axis-4 Sample #134
140-143	Float	Axis-4 Sample #135
144-147	Float	Axis-4 Sample #136
148-151	Float	Axis-4 Sample #137
Continue...		

Byte	Format	Description
...Continue		
152-155	Float	Axis-4 Sample #138
156-159	Float	Axis-4 Sample #139
160-163	Float	Axis-4 Sample #140
164-167	Float	Axis-4 Sample #141
168-171	Float	Axis-4 Sample #142
172-175	Float	Axis-4 Sample #143
176-179	Float	Axis-4 Sample #144
180-183	Float	Axis-4 Sample #145
184-187	Float	Axis-4 Sample #146
188-191	Float	Axis-4 Sample #147
192-195	Float	Axis-4 Sample #148
196-199	Float	Axis-4 Sample #149

Command-Specific Response Codes

Code	Class	Description
0	Success	No Command-Specific Errors
1-31		Undefined
32	Error	Device Busy
33-127		Undefined

8.3.33 Command #164: Read Curve Samples Axis-4 – Part 4

This command allows reading the Axis-4 samples (150-200) of the Curve selected by command #147.

Request Data Bytes

Byte	Format	Description
------	--------	-------------

Response Data Bytes

Byte	Format	Description
0-3	Float	Axis-4 Sample #150
4-7	Float	Axis-4 Sample #151
8-11	Float	Axis-4 Sample #152
12-15	Float	Axis-4 Sample #153
16-19	Float	Axis-4 Sample #154
20-23	Float	Axis-4 Sample #155
24-27	Float	Axis-4 Sample #156
28-31	Float	Axis-4 Sample #157
32-35	Float	Axis-4 Sample #158
36-39	Float	Axis-4 Sample #159
40-43	Float	Axis-4 Sample #160
44-47	Float	Axis-4 Sample #161
48-51	Float	Axis-4 Sample #162
52-55	Float	Axis-4 Sample #163
56-59	Float	Axis-4 Sample #164
60-63	Float	Axis-4 Sample #165
64-67	Float	Axis-4 Sample #166
68-71	Float	Axis-4 Sample #167
72-75	Float	Axis-4 Sample #168
76-79	Float	Axis-4 Sample #169
80-83	Float	Axis-4 Sample #170
84-87	Float	Axis-4 Sample #171
88-91	Float	Axis-4 Sample #172
92-95	Float	Axis-4 Sample #173
96-99	Float	Axis-4 Sample #174
100-103	Float	Axis-4 Sample #175
104-107	Float	Axis-4 Sample #176
108-111	Float	Axis-4 Sample #177
112-115	Float	Axis-4 Sample #178
116-119	Float	Axis-4 Sample #179
120-123	Float	Axis-4 Sample #180
124-127	Float	Axis-4 Sample #181
128-131	Float	Axis-4 Sample #182
132-135	Float	Axis-4 Sample #183
136-139	Float	Axis-4 Sample #184
140-143	Float	Axis-4 Sample #185
144-147	Float	Axis-4 Sample #186
148-151	Float	Axis-4 Sample #187
Continue...		

Byte	Format	Description
...Continue		
152-155	Float	Axis-4 Sample #188
156-159	Float	Axis-4 Sample #189
160-163	Float	Axis-4 Sample #190
164-167	Float	Axis-4 Sample #191
168-171	Float	Axis-4 Sample #192
172-175	Float	Axis-4 Sample #193
176-179	Float	Axis-4 Sample #194
180-183	Float	Axis-4 Sample #195
184-187	Float	Axis-4 Sample #196
188-191	Float	Axis-4 Sample #197
192-195	Float	Axis-4 Sample #199
196-199	Float	Axis-4 Sample #199
200-203	Float	Axis-4 Sample #200

Command-Specific Response Codes

Code	Class	Description
0	Success	No Command-Specific Errors
1-31		Undefined
32	Error	Device Busy
33-127		Undefined

8.3.34 Command #165: Read Curve Samples Axis-5 – Part 1

This command allows reading the Axis-5 samples (0-49) of the Curve selected by command #147.

Request Data Bytes

Byte	Format	Description
------	--------	-------------

Response Data Bytes

Byte	Format	Description
0-3	Float	Axis-5 Sample #0
4-7	Float	Axis-5 Sample #1
8-11	Float	Axis-5 Sample #2
12-15	Float	Axis-5 Sample #3
16-19	Float	Axis-5 Sample #4
20-23	Float	Axis-5 Sample #5
24-27	Float	Axis-5 Sample #6
28-31	Float	Axis-5 Sample #7
32-35	Float	Axis-5 Sample #8
36-39	Float	Axis-5 Sample #9
40-43	Float	Axis-5 Sample #10
44-47	Float	Axis-5 Sample #11
48-51	Float	Axis-5 Sample #12
52-55	Float	Axis-5 Sample #13
56-59	Float	Axis-5 Sample #14
60-63	Float	Axis-5 Sample #15
64-67	Float	Axis-5 Sample #16
68-71	Float	Axis-5 Sample #17
72-75	Float	Axis-5 Sample #18
76-79	Float	Axis-5 Sample #19
80-83	Float	Axis-5 Sample #20
84-87	Float	Axis-5 Sample #21
88-91	Float	Axis-5 Sample #22
92-95	Float	Axis-5 Sample #23
96-99	Float	Axis-5 Sample #24
100-103	Float	Axis-5 Sample #25
104-107	Float	Axis-5 Sample #26
108-111	Float	Axis-5 Sample #27
112-115	Float	Axis-5 Sample #28
116-119	Float	Axis-5 Sample #29
120-123	Float	Axis-5 Sample #30
124-127	Float	Axis-5 Sample #31
128-131	Float	Axis-5 Sample #32
132-135	Float	Axis-5 Sample #33
136-139	Float	Axis-5 Sample #34
140-143	Float	Axis-5 Sample #35
144-147	Float	Axis-5 Sample #36
148-151	Float	Axis-5 Sample #37
152-155	Float	Axis-5 Sample #38
Continue...		

Byte	Format	Description
...Continue		
156-159	Float	Axis-5 Sample #39
160-163	Float	Axis-5 Sample #40
164-167	Float	Axis-5 Sample #41
168-171	Float	Axis-5 Sample #42
172-175	Float	Axis-5 Sample #43
176-179	Float	Axis-5 Sample #44
180-183	Float	Axis-5 Sample #45
184-187	Float	Axis-5 Sample #46
188-191	Float	Axis-5 Sample #47
192-195	Float	Axis-5 Sample #48
196-199	Float	Axis-5 Sample #49

Command-Specific Response Codes

Code	Class	Description
0	Success	No Command-Specific Errors
1-31		Undefined
32	Error	Device Busy
33-127		Undefined

8.3.35 Command #166: Read Curve Samples Axis-5 – Part 2

This command allows reading the Axis-5 samples (50-99) of the Curve selected by command #147.

Request Data Bytes

Byte	Format	Description
------	--------	-------------

Response Data Bytes

Byte	Format	Description
0-3	Float	Axis-5 Sample #50
4-7	Float	Axis-5 Sample #51
8-11	Float	Axis-5 Sample #52
12-15	Float	Axis-5 Sample #53
16-19	Float	Axis-5 Sample #54
20-23	Float	Axis-5 Sample #55
24-27	Float	Axis-5 Sample #56
28-31	Float	Axis-5 Sample #57
32-35	Float	Axis-5 Sample #58
36-39	Float	Axis-5 Sample #59
40-43	Float	Axis-5 Sample #60
44-47	Float	Axis-5 Sample #61
48-51	Float	Axis-5 Sample #62
52-55	Float	Axis-5 Sample #63
56-59	Float	Axis-5 Sample #64
60-63	Float	Axis-5 Sample #65
64-67	Float	Axis-5 Sample #66
68-71	Float	Axis-5 Sample #67
72-75	Float	Axis-5 Sample #68
76-79	Float	Axis-5 Sample #69
80-83	Float	Axis-5 Sample #70
84-87	Float	Axis-5 Sample #71
88-91	Float	Axis-5 Sample #72
92-95	Float	Axis-5 Sample #73
96-99	Float	Axis-5 Sample #74
100-103	Float	Axis-5 Sample #75
104-107	Float	Axis-5 Sample #76
108-111	Float	Axis-5 Sample #77
112-115	Float	Axis-5 Sample #78
116-119	Float	Axis-5 Sample #79
120-123	Float	Axis-5 Sample #80
124-127	Float	Axis-5 Sample #81
128-131	Float	Axis-5 Sample #82
132-135	Float	Axis-5 Sample #83
136-139	Float	Axis-5 Sample #84
140-143	Float	Axis-5 Sample #85
144-147	Float	Axis-5 Sample #86
148-151	Float	Axis-5 Sample #87
152-155	Float	Axis-5 Sample #88
Continue...		

Byte	Format	Description
...Continue		
156-159	Float	Axis-5 Sample #89
160-163	Float	Axis-5 Sample #90
164-167	Float	Axis-5 Sample #91
168-171	Float	Axis-5 Sample #92
172-175	Float	Axis-5 Sample #93
176-179	Float	Axis-5 Sample #94
180-183	Float	Axis-5 Sample #95
184-187	Float	Axis-5 Sample #96
188-191	Float	Axis-5 Sample #97
192-195	Float	Axis-5 Sample #98
196-199	Float	Axis-5 Sample #99

Command-Specific Response Codes

Code	Class	Description
0	Success	No Command-Specific Errors
1-31		Undefined
32	Error	Device Busy
33-127		Undefined

8.3.36 Command #167: Read Curve Samples Axis-5 – Part 3

This command allows reading the Axis-5 samples (100-149) of the Curve selected by command #147.

Request Data Bytes

Byte	Format	Description
------	--------	-------------

Response Data Bytes

Byte	Format	Description
0-3	Float	Axis-5 Sample #100
4-7	Float	Axis-5 Sample #101
8-11	Float	Axis-5 Sample #102
12-15	Float	Axis-5 Sample #103
16-19	Float	Axis-5 Sample #104
20-23	Float	Axis-5 Sample #105
24-27	Float	Axis-5 Sample #106
28-31	Float	Axis-5 Sample #107
32-35	Float	Axis-5 Sample #108
36-39	Float	Axis-5 Sample #109
40-43	Float	Axis-5 Sample #110
44-47	Float	Axis-5 Sample #111
48-51	Float	Axis-5 Sample #112
52-55	Float	Axis-5 Sample #113
56-59	Float	Axis-5 Sample #114
60-63	Float	Axis-5 Sample #115
64-67	Float	Axis-5 Sample #116
68-71	Float	Axis-5 Sample #117
72-75	Float	Axis-5 Sample #118
76-79	Float	Axis-5 Sample #119
80-83	Float	Axis-5 Sample #120
84-87	Float	Axis-5 Sample #121
88-91	Float	Axis-5 Sample #122
92-95	Float	Axis-5 Sample #123
96-99	Float	Axis-5 Sample #124
100-103	Float	Axis-5 Sample #125
104-107	Float	Axis-5 Sample #126
108-111	Float	Axis-5 Sample #127
112-115	Float	Axis-5 Sample #128
116-119	Float	Axis-5 Sample #129
120-123	Float	Axis-5 Sample #130
124-127	Float	Axis-5 Sample #131
128-131	Float	Axis-5 Sample #132
132-135	Float	Axis-5 Sample #133
136-139	Float	Axis-5 Sample #134
140-143	Float	Axis-5 Sample #135
144-147	Float	Axis-5 Sample #136
148-151	Float	Axis-5 Sample #137
Continue...		

Byte	Format	Description
...Continue		
152-155	Float	Axis-5 Sample #138
156-159	Float	Axis-5 Sample #139
160-163	Float	Axis-5 Sample #140
164-167	Float	Axis-5 Sample #141
168-171	Float	Axis-5 Sample #142
172-175	Float	Axis-5 Sample #143
176-179	Float	Axis-5 Sample #144
180-183	Float	Axis-5 Sample #145
184-187	Float	Axis-5 Sample #146
188-191	Float	Axis-5 Sample #147
192-195	Float	Axis-5 Sample #148
196-199	Float	Axis-5 Sample #149

Command-Specific Response Codes

Code	Class	Description
0	Success	No Command-Specific Errors
1-31		Undefined
32	Error	Device Busy
33-127		Undefined

8.3.37 Command #168: Read Curve Samples Axis-5 – Part 4

This command allows reading the Axis-5 samples (150-200) of the Curve selected by command #147.

Request Data Bytes

Byte	Format	Description
------	--------	-------------

Response Data Bytes

Byte	Format	Description
0-3	Float	Axis-5 Sample #150
4-7	Float	Axis-5 Sample #151
8-11	Float	Axis-5 Sample #152
12-15	Float	Axis-5 Sample #153
16-19	Float	Axis-5 Sample #154
20-23	Float	Axis-5 Sample #155
24-27	Float	Axis-5 Sample #156
28-31	Float	Axis-5 Sample #157
32-35	Float	Axis-5 Sample #158
36-39	Float	Axis-5 Sample #159
40-43	Float	Axis-5 Sample #160
44-47	Float	Axis-5 Sample #161
48-51	Float	Axis-5 Sample #162
52-55	Float	Axis-5 Sample #163
56-59	Float	Axis-5 Sample #164
60-63	Float	Axis-5 Sample #165
64-67	Float	Axis-5 Sample #166
68-71	Float	Axis-5 Sample #167
72-75	Float	Axis-5 Sample #168
76-79	Float	Axis-5 Sample #169
80-83	Float	Axis-5 Sample #170
84-87	Float	Axis-5 Sample #171
88-91	Float	Axis-5 Sample #172
92-95	Float	Axis-5 Sample #173
96-99	Float	Axis-5 Sample #174
100-103	Float	Axis-5 Sample #175
104-107	Float	Axis-5 Sample #176
108-111	Float	Axis-5 Sample #177
112-115	Float	Axis-5 Sample #178
116-119	Float	Axis-5 Sample #179
120-123	Float	Axis-5 Sample #180
124-127	Float	Axis-5 Sample #181
128-131	Float	Axis-5 Sample #182
132-135	Float	Axis-5 Sample #183
136-139	Float	Axis-5 Sample #184
140-143	Float	Axis-5 Sample #185
144-147	Float	Axis-5 Sample #186
148-151	Float	Axis-5 Sample #187
Continue...		

Byte	Format	Description
...Continue		
152-155	Float	Axis-5 Sample #188
156-159	Float	Axis-5 Sample #189
160-163	Float	Axis-5 Sample #190
164-167	Float	Axis-5 Sample #191
168-171	Float	Axis-5 Sample #192
172-175	Float	Axis-5 Sample #193
176-179	Float	Axis-5 Sample #194
180-183	Float	Axis-5 Sample #195
184-187	Float	Axis-5 Sample #196
188-191	Float	Axis-5 Sample #197
192-195	Float	Axis-5 Sample #198
196-199	Float	Axis-5 Sample #199
200-203	Float	Axis-5 Sample #200

Command-Specific Response Codes

Code	Class	Description
0	Success	No Command-Specific Errors
1-31		Undefined
32	Error	Device Busy
33-127		Undefined

8.4 Common Tables

Table 1. Expanded Device Type Codes

Expanded Device Code (Hex)	Description	Company Name
B77E	HRT2000v4	BIFFI
B77D	HRTIMVS2000	BIFFI
B77C	HRT_IMVS2000v2	BIFFI
B77B	HRT_ECU1000	BIFFI

Other manufacturer devices are not listed.

Table 2. Engineering Unit Codes

Code	Description
0	Not Classified
6	bar
39	Milliamperes
51	Seconds
53	Days
57	Percent
250	Not Used
251	None

Only Unit Codes used by HRT_ECU1000 are listed.

Table 3. Transfer Function Codes

Code	Transfer Function Description
0	Linear
1	Square Root
2	Square Root Third Power
3	Square Root Fifth Power
4	Special Curve
5	Square
230	Discrete (Switch)
231	Square Root Plus Special Care
232	Square Root Third Power Plus Special Curve
233	Square Root Fifth Power Plus Special Curve
240-250	Not Used
251	None
252	Unknown
253	Special

Table 6. Alarm Selection Codes

Code	Alarm Selection Description
0	High
1	Low
239	Hold Last Output Value
240-250	Not Used
251	None
252	Unknown
253	Special

Table 7. Write Protect Codes

Code	Physical Signal Definition
0	No – No Write Protected
1	Yes – Write Protected
250	Not used
251	None
252	Unknown
253	Special

Table 8. Manufacturer Identification Codes

Code (Dec)	Code (Hex)	Company Name
183	00B7	BIFFI

Other manufacturers are not listed.

Table 9. Burst Mode Control Codes

Code	Burst Mode Control Definition
0	Off
1	Enable Burst on Token-Passing Data Link Layer only
2	Enable Burst on TDMA Data-Link Layer only
3	Enable Burst on TDMA and Token-Passing Data Link Layers
250	Reserved
251	Reserved
252	Reserved
253	Reserved

Only codes 0 and 1 are supported by HRT_ECU1000 field device.

Table 10. Physical Signalling Codes

Code	Physical Signal Definition
0	Bell 202 current
1	Bell 202 voltage
2	RS-485
3	RS-232
4	Wireless
6	Special

Table 11. Flag Assignments

Code	Flag Assignment Definition
0x00	Undefined
0x01	Multi-Sensor Field Device
0x02	EEPROM Control
0x04	Protocol Bridge Device
0x08	IEEE 802.15.4 2.4GHz DSS with O-QPSK Modulation
0x10-0x20	Undefined
0x40	C8psk Capable Field Device
0x80	C8psk In Multi-Drop Only

Table 16. Loop Current Mode Codes

Code	Loop Current Mode Description
0	Disabled
1	Enabled

Table 17. Extended Device Status Codes

Code	Description
0x01	Maintenance Required. This bit is set to indicate that, while the device has not malfunctioned, the Field Device requires maintenance.
0x02	Device Variable Alert. This bit is set if any Device Variable is in Alarm or Warning State. The host should identify the Device Variable(s) causing this to be set using the Device Variable Status indicators.
0x04	Critical Power Failure. For devices that can operate from stored power. This bit is set when that power is becoming critically low.
0x08	Failure. When this bit is set one or more Device Variables are invalid due to a malfunction in the field device or its peripherals.
0x10	Out of Specification. When set, this bit indicates deviations from the permissible ambient or process conditions have been detected that may compromise measurement or control accuracy.
0x20	Function Check. This bit is set if one or more Device Variable are temporarily invalid due to ongoing work on the device.

Table 19. Write Device Variable Code

Code	Write Device Variable Command Description
0	Normal
1	Fixed Value

Table 20. Device Variable Family Codes

Code	Device Variable Family
0-3	Reserved
4	Temperature
5	Pressure
6	Valve / Actuator
7	Simple PID Control
8	pH
9	Conductivity
10	Totalizer
11	Level
12	Vortex Flow
13	Mag Flow
14	Coriolis Flow
132-249	Reserved
250	Not Used

Table 21. Device Variable Classification Codes

Code	Device Variable Classification
0	Device Variable Not Classified
1-63	Reserved
65	Pressure
250	Not Used

Only Classification Codes used by HRT_ECU1000 are listed.

Table 26. Analog Channel Flags

Code	Flag Definition
0x01	When set, this Analog Channel is a field device analog input channel. When reset to 0, the analog channel is an analog output.

Table 33. Burst Message Trigger Modes

Code	Burst Message Trigger Mode Description
0	Continuous. The burst message is published continuously at (worst case) the minimum update period.
1	Window. The burst message is triggered when the source value deviates more than the specified trigger value.
2	Rising. The burst message is triggered when source value rises above the specified trigger value.
3	Falling. The burst message is triggered when the source value falls below the specified trigger value.
4	On-Change. The burst message is triggered when any value in the message changes.

Table 57. Device Profile Code

Code	Device Profile Code Description
1	HART Process Automation Device
2	HART Discrete Device
3	Hybrid: Process Automation + Discrete
4	I/O System
129	WirelessHART Process Automation Device
130	WirelessHART Discrete Device
131	WirelessHART Hybrid: Process Automation + Discrete
132	WirelessHART Gateway
141	WirelessHART Process Adapter
142	WirelessHART Discrete Adapter
144	WirelessHART-Enable Handheld/Portable Maintenance Tool

Table 65. Device Variable Property Codes

Code	Device Profile Code Description
0x01	Device Variable is not calculated by Field Device
0x02- 0x40	Undefined.
0x80	Device Variable is being Simulated.

9 DEVICE VARIABLES

9.1 List of Device Variables

Dev. Var.	Description	Classification	Unit Code	R/W	Min.	Max.	Type	Details
0	Actuator Position	Not Classified	Percent	R	-150	150	FLOAT	See 9.3
1	Position Demand	Not Classified	Percent	R	0	100	FLOAT	See 9.4
2	Demand Source	Not Classified	None	R	0	2	ENUM	See 9.5
3	Status Summary	Not Classified	None	R	0	3	ENUM	See 9.6
4	Remote not available	Not Classified	None	R	0	1	ENUM	See 9.7
5	Maintenance Request	Not Classified	None	R	0	255	FLOAT	See 9.8
6	Status1	Not Classified	None	R			ENUM_BIT	See 9.9
7	Status2	Not Classified	None	R			ENUM_BIT	See 9.10
8	Failure	Not Classified	None	R			ENUM_BIT	See 9.11
9	Alarm1	Not Classified	None	R			ENUM_BIT	See 9.12
10	Alarm2	Not Classified	None	R			ENUM_BIT	See 9.13
11	Alarm3	Not Classified	None	R			ENUM_BIT	See 9.14
12	Oil Pressure	Pressure	Bar	R	-1000	1000	FLOAT	See 9.15
13	Temperature	Temperature	°C	R	-32768	32768	FLOAT	See 9.16
14	Humidity	Not Classified	%	R	0	100	FLOAT	See 9.17
15	Process AI	Not Classified	None	R	0	4095	FLOAT	See 9.18
16	Interlock AI	Not Classified	None	R	0	4095	FLOAT	See 9.19
17	Next Pump Switch – Hours	Not Classified	Hours	R	0	10000	FLOAT	See 9.20
18	Next Pump Switch – Minutes	Not Classified	Minutes	R	0	59	FLOAT	See 9.21
19	Pressure1	Pressure	Bar	R	-1000	65535	FLOAT	See 9.22
20	Pressure2	Pressure	Bar	R	-1000	65535	FLOAT	See 9.23
19	Actuator Command 1	Not Classified	None	RW	0	2	ENUM	See 9.24
20	Actuator Command 2	Not Classified	None	RW	0	3	ENUM	See 9.25
21	Actuator Command 3	Not Classified	None	RW	0	1	ENUM	See 9.26
22	Actuator Command 4	Not Classified	None	RW	0	6	ENUM	See 9.27
23	Clear Failure/Alarm	Not Classified	None	RW	0	1	ENUM	See 9.28
244	Percent Range	Not Classified	Percent	R	0	100	FLOAT	See 9.29
245	Loop Current	Not Classified	mA	R			FLOAT	See 9.30
246	PV*			R				See 9.31
247	SV*			R				See 9.32
248	TV*			R				See 9.33
249	QV*			R				See 9.34

*It depends on field device settings with Command #51 (see Section 8.2.3 for details).

Default PV is Position Demand (Device Variable 1).

Default SV is Actuator Position (Device Variable 0).

Default TV is Status Summary (Device Variable 3).

Default QV is Maintenance Request (Device Variable 5).

9.2 Device Variable Status Byte

All cyclical process data include a Device Variable Status byte.

The most significant two bits (bits 7 and 6) of every Device Variable Status byte return the overall status of the Device or Dynamic Variable value. The next two bits (bits 5 and 4) indicate whether the Device Variable value is limited. These four bits provide useful status about the Device Variable's value. The content of the lower 4 bits depend on the Device Variable Family. Each Device Family can have its own Device Family-specific status defining the least significant bits. If set, bit3 indicates the additional Device Family-specific status is available via the appropriate Device Family Command.

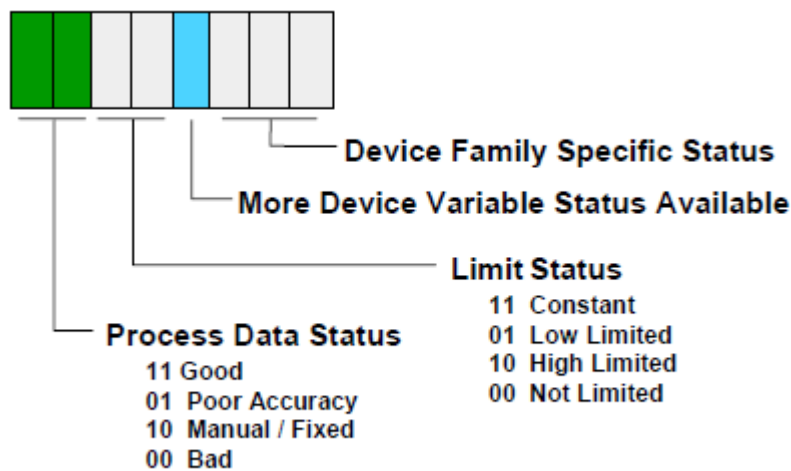

HRT_IMVS2000v2 doesn't provide Device Family-specific status for Dynamic and Device Variables, therefore last 4 bits are always set to 0.

9.3 Device Variable 0: Actuator Position

This variable indicates the current position of the actuator.

9.4 Device Variable 1: Position Demand

This variable indicates the position demand.

9.5 Device Variable 2: Demand Source

This variable indicates the source of the Position Demand signal.

It's an enumerated variable; it's not possible to write this data. The possible values are:

Value	Description
0	External 4-20mA
1	BUS
2	Internal

9.6 Device Variable 3: Status Summary

This variable indicates the general status of the device.

It's an enumerated variable; it's not possible to write this data. The possible values are:

Value	Description
0	Normal
1	Failure
2	Alarm
3	Failure and Alarm

9.7 Device Variable 4: Remote Not Available

This variable indicates if remote commands are available.

It's an enumerated variable; it's not possible to write this data. The possible values are:

Value	Description
0	Available
1	Not Available

9.8 Device Variable 5: Maintenance Request

This variable indicates if the device requires Maintenance operations.

It's an enumerated variable; it's not possible to write this data. The possible values are:

Value	Description
0	Ok
1	Maintenance Request

9.9 Device Variable 6: Status1

This variable shows the status of the actuator.

It's a bit enumerated variable; it's not possible to write this data. The possible values are:

Bit	Description
0	Normal
1	Failure
2	Alarm
3	Remote not available
4	Maintenance Request
5	Open
6	Closed
7	Pump1 On
8	Pump2 On
9	Opt-SOV2
10	Local
11	ESD
12	PST
13	Rem-HW
14	Interlock OP
15	Interlock CL
16-31	Reserved

9.10 Device Variable 7: Status2

This variable shows the status of the actuator.

It's a bit enumerated variable; it's not possible to write this data. The possible values are:

Bit	Description
0	Failsafe
1	Opening
2	Closing
3	No-Out
4	Control
5	Configuration
6	Tracking
7	Stay in position
8	Switch to auto
9	Position > xx%
10	Position < xx%
11	Auto
12	Manual
13	Last PST Result (1 = Ok)
14-31	Reserved

9.11 Device Variable 8: Failure

This variable shows the status of the failures of the actuator.

It's a bit enumerated variable; it's not possible to write this data. The possible values are:

Bit	Description
0	Actuator Position
1	Position Demand
2	Temperature
3	Proportional Valve
4	Power Supply
5	Hardware 0
6	SW Error 0
7	HPU Failure
8	Failsafe
9	Stayput by SOV
10	BUS Control
11-31	Reserved

9.12 Device Variable 9: Alarm1

This variable shows the alarms status of the actuator.

It's a bit enumerated variable; it's not possible to write this data. The possible values are:

Bit	Description
0	High Temperature
1	Low Temperature
2	Stroke Limit
3	Humidity
4	Reserved
5	Reserved
6	Reserved
7	Fail to position
8	Pump1 Filter
9	Pump2 Filter
10	Oil Level
11	Low Oil Pressure
12	Oil Temperature
13	High Oil Pressure
14	HPU Pressure Transmitter
15	HPU Signalling Switch
16-31	Reserved

9.13 Device Variable 10: Alarm2

This variable shows the alarms status of the actuator.

It's a bit enumerated variable; it's not possible to write this data. The possible values are:

Bit	Description
0	HPU General Sensor
1	Pump1 Power Supply
2	Pump1 Motor TH
3	Not Used
4	General Sensor Pump1
5	Pump2 Power Supply
6	Pump2 Motor TH
7	Display Card
8	General Sensor Pump2
9	Memory FL
10	Memory NVR
11	Characterization
12	PST T-PST
13	PST OV-TR
14	PST T-RET
15	PST RESET
16-31	Reserved

9.14 Device Variable 11: Alarm3

This variable shows the alarms status of the actuator.
 It's a bit enumerated variable; it's not possible to write this data. The possible values are:

Bit	Description
0	Hyd. Valve Leak
1	Max Start Pump1
2	Max Start Pump2
3	Max Start D-SOV
4	Hand-Pump
5	Max Time Pump1
6	Max Time Pump2
7	PWM Utilization
8-31	Reserved

9.15 Device Variable 12: Oil Pressure

This variable indicates the value of the Oil Pressure.
 It's not possible to write this variable.

9.16 Device Variable 13: Temperature

This variable indicates the value of the temperature of electronics cards' environment.
 It's not possible to write this variable.

9.17 Device Variable 14: Humidity

This variable indicates the Humidity of electronic cards' environment.
 It's not possible to write this variable.

9.18 Device Variable 15: Process AI

This variable indicates the value of the Analog Input "Process AI".
 It's not possible to write this variable.

9.19 Device Variable 16: Interlock AI

This variable indicates the value of the Analog Input "Interlock".
 It's not possible to write this variable.

9.20 Device Variable 17: Next Pump Switch - Hours

This variable indicates the time to the next pump switch.
It's not possible to write this variable.

9.21 Device Variable 18: Next Pump Switch - Minutes

This variable indicates the time to the next pump switch.
It's not possible to write this variable.

9.22 Device Variable 19: Pressure1

This variable indicates the value of the Pressure1.
It's not possible to write this variable.

9.23 Device Variable 20: Pressure2

This variable indicates the value of the Pressure2.
It's not possible to write this variable

9.24 Device Variable 21: Actuator Command 1

This variable permits to select the Operating Mode of the actuator.
It's an enumerated variable; the possible values are:

Value	Description
0	No Command
1	Auto Mode
2	Manual Mode

9.25 Device Variable 22: Actuator Command 2

This variable permits to send a command to the actuator.
It's an enumerated variable; the possible values are:

Value	Description
0	Manual Stop
1	Manual Open
2	Manual Close
3	PST

9.26 Device Variable 23: Actuator Command 3

This variable permits to send an ESD Command to the actuator.
It's an enumerated variable; the possible values are:

Value	Description
0	ESD Off
1	ESD On

9.27 Device Variable 24: Actuator Command 4

This variable permits to send an Interlock Command to the actuator.
It's an enumerated variable; the possible values are:

Value	Description
0	No Command
1	Interlock OP On
2	Interlock OP Off
3	Interlock CL On
4	Interlock CL Off
5	Interlock On (OP + CL)
6	Interlock Off (No Interlock)

9.28 Device Variable 25: Clear Failure/Alarm

This variable permits to clear the Failure/Alarm Lists.
It's an enumerated variable; the possible values are:

Value	Description
0	No Command
1	Clear Failure/Alarm

9.29 Device Variable 244: Percent Range

This variable indicates the percentage corresponding to the Loop Current signal.
It's not possible to write this variable.

9.30 Device Variable 245: Loop Current

This variable indicates the value of the analogue output current.
It's not possible to write this variable.

9.31 Device Variable 246: Primary Variable

This variable indicates the PV.
PV is Device Variable 1: Position .

9.32 Device Variable 247: Secondary Variable

This variable indicates the SV.
Default SV is Device Variable 0: Actuator Position.
To select the Secondary Variable see Section 8.2.3.

9.33 Device Variable 248: Tertiary Variable

This variable indicates the TV.
Default TV is Device Variable 3: Status Summary.
To select the Tertiary Variable see Section 8.2.3.

9.34 Device Variable 249: Quaternary Variable

This variable indicates the QV.
Default QV is Device Variable 5: Maintenance Request.
To select the Quaternary Variable see Section 8.2.3.

10 Device Specific Tables

Legend for all tables in this section:

All unit codes are referenced to Common Table 2 (Section 8.4)

CC = Configuration Change Counter

Y = Configuration Change Counter value is incremented when the parameter value is changed.

N = Configuration Change Counter value isn't incremented when the parameter value is changed.

Min = Minimum value

Max = Maximum value

R = Read Only

W = Write Only (Read as 0)

RW = Read and Write

10.1 Parameter2 Codes

Code	Description	Unit Code	R/W	Min	Max	CC
0	Position < xx%	Percent	RW	1	100	Y
1	Position > xx%	Percent	RW	0	99	Y
2	Max Time to Position	Seconds	RW	4	255	Y
3	Speed SOV %	Percent	RW	1	50	Y
4	Max Time to Pressure	Minutes	RW	0	255	Y
5	Delay before failsafe	Seconds	RW	0	100	Y
6	Position of failsafe	Percent	RW	0	100	Y
7	PST Period	Days	RW	1	1000	Y
8	PST Travel	Percent	RW	1	40	Y
9	PST Pause	Seconds	RW	0	60	Y
10	Max PST Duration	Seconds	RW	2	1000	Y
11	Max T-PST	Percent	RW	0	1000	Y
12	Max T-RET	Percent	RW	0	1000	Y
13	Max OV-TRAV	Percent	RW	1	100	Y
14	ESD Position	Percent	RW	0	100	Y
15	ESD Duration	Seconds	RW	1	100	Y

10.2 ParameterE Codes

Code	Description	Unit Code	R/W	Min	Max	CC
0	Select Open Stroke Signature	None	RW	See section 10.2.1.1		Y
1	Select Close Stroke Signature	None	RW	See section 10.2.1.1		Y
2	Select PST Stroke Signature	None	RW	See section 10.2.1.1		Y
3	Select Recorder Stroke Signature	None	RW	See section 10.2.1.1		Y
4	Pump1 Mode	None	RW	See section 10.2.1.2		Y
5	Pump2 Mode	None	RW	See section 10.2.1.2		Y
6	Recording Duration	None	RW	See section 10.2.1.3		Y
7	Stop Condition	None	RW	See section 10.2.1.4		Y
8	Recorder Mode	None	RW	See section 10.2.1.5		Y
9	Recording Duration OP	None	RW	See section 10.2.1.3		Y
10	Recording Duration CL	None	RW	See section 10.2.1.3		Y
11	Recording Duration PST	None	RW	See section 10.2.1.3		Y
12	Action of Failsafe	None	RW	See section 10.2.1.6		Y
13	PST Start	None	RW	See section 10.2.1.7		Y
14	Input Characterization	None	RW	See section 10.2.1.8		Y
15	Input Characteristic	None	RW	See section 10.2.1.9		Y
16	ESD Action	None	RW	See section 10.2.1.6		Y

10.2.1 ParameterE Tables

10.2.1.1 Table E1

Code	Description
1	Curve1
2	Curve2
3	Curve3
4	Curve4
5	Curve5

10.2.1.2 Table E2

Code	Description
0	Off
1	Auto

10.2.1.3 Table E3

Code	Description
0	2 Sec.
1	4 Sec.
2	10 Sec.
3	20 Sec.
4	50 Sec.
5	100 Sec.
6	200 Sec.
7	500 Sec.
8	1000 Sec.

10.2.1.4 Table E4

Code	Description
0	Failure
1	Alarm
2	Position < 5%
3	Position > 95%

10.2.1.5 Table E5

Code	Description
0	Off
1	Record
2	PST
3	OP Stroke
4	CL Stroke
5	Multi Stroke

10.2.1.6 Table E6

Code	Description
0	Off
1	Tracking
2	Stayput
3	Go to position %

10.2.1.7 Table E7

Code	Description
0	Off
1	Manual
2	Auto
3	Auto-Manual

10.2.1.8 Table E8

Code	Description
0	Off
1	On

10.2.1.9 Table E9

Code	Description
0	Off
1	Linear 100-0
2	Custom Increase
3	Custom Decrease

10.3ParameterBE Codes

Code	Description	Unit Code	R/W	Min	Max	CC
0	Y-axis	None	RW	See Section 10.3.1		Y

10.3.1Table BE1

Bit	Description
b0	Position Demand
b1	Actuator Position
b2	HPU Oil Pressure
b3	Position Erro
b4	AO1%
b5	Interlock
b6	PST Pressure1
b7	PST Pressure2
b8	PST Trigger

10.4ParameterF Codes

Code	Description	Unit Code	R/W	Min	Max	CC
0	Dead Band	Percent	RW	0	10	Y
1	ESD Delay	Seconds	RW	0.1	10	Y

10.5Date Codes

Code	Description	R/W	Min	Max	CC
0	Next PST	R	01/01/2010 00:00:00	31/12/2099 23:59:59	Y
1	Date and Time	RW	01/01/2010 00:00:00	31/12/2099 23:59:59	N
2	Maintenance Request Date	RW	01/01/2010 00:00:00	31/12/2099 23:59:59	Y

10.6 Time Codes

Code	Description	R/W	Min	Max	CC
0	PST Time	RW	00:00:00	23:59:59	Y

10.7String16 Codes

Code	Description	R/W	CC
0	ECU1000 Cabinet Serial Number	R	Y
1	Actuator Serial Number	R	Y
2	Valve Tag	RW	Y

10.8String12 Codes

Code	Description	R/W	CC
0	Base SW Version	R	N
1	Display SW Version	R	N

10.9 Failure Codes

Code	Description
0	None
1	N.D.
2	Actuator Position
3	Position Demand
4	Temperature
5	Proportional Valve
6	Power Supply
7	Hardware 0
8	SW Error 0
9	HPU Failure
10	Failsafe
11	Stayput by SOV
12	Bus Control

10.10 Alarm Codes

Code	Description
0	None
1	N.D.
2	High Temperature
3	Low Temperature
4	Stroke Limit
5	Humidity
6	Acceleration -x
7	Acceleration -y
8	Acceleration -z
9	Fail to position
10	Pump1 Filter
11	Pump2 Filter
12	Oil Level
13	Oil Low Pressure
14	Oil Temperature
15	Oil High Pressure
16	HPU Pressure Transmitter
17	HPU Signalling Switch
18	HPU General Sensor
19	Pump1 Power Supply
20	Pump1 Motor TH
21	Not Used
22	General Sensor Pump1
23	Pump2 Power Supply
24	Pump2 Motor TH
25	Display Card
26	General Sensor Pump2
27	Memory-FL
28	Memory-NVR
29	Characterization
30	PST T-PST
31	PST OV-TR
32	PST T-RET
33	PST Reset
34	Hydraulic Valve Leakage
35	Max. Start Pump1
36	Max. Start Pump2
37	Max. Start D-SOV
38	Hand Pump
39	Max. Time Pump1
40	Max. Time Pump2
41	PWM Utilization %

10.11 Event Action

Code	Description
0	None
1	N.D.
2	Open
3	Close
4	No-Out
5	Test
6	-

10.12 Event Codes

Code	Description
0	None
1	N.D.
2	Power On
3	Remote Manual
4	Local Command
5	Bus Manual
6	ESD
7	Limit Calibration
8	Failsafe
9	Demand <5>95%-HW
10	Demand <5>95%-Bus
11	Demand <5>95%-Loc
12	PST
13	Configuration
14	Restore Configuration
15	Full Default
16	Tracking
17	CRC Memory-EE
18	CRC Memory-FL
19	CRC Memory-NVR
20	Pump Switch
21	Interlock

10.13 Curve Type

Code	Description
0	PST
1	Open
2	Close
3	Recorder

10.14 Axis Variable

Code	Description
0	Position Demand
1	Actuator Position
2	HPU Oil Pressure
3	Position Error
4	AO1%
5	Interlock
6	PST Pressure1
7	PST Pressure2
8	PST Trigger
9	Time

10.15 Axis Engineering Unit Codes

Code	Description
0	
1	%
2	bar
3	°C
4	mm
5	m
6	bit
7	mA
8	V
9	Sec

11 Bus Menu

This section describes the ECU1000 HART Bus Menu available by local operator interface and Biffi Assistant (see [1] for details).

Bus	..
	HART Device ID
	HART Polling Address
	HART Mode
	SW Rev Level
	FW Rev Level

PARAMETER NAME	DESCRIPTION	RANGE	DEFAULT VALUE	R/W (1)	AVAILABLE ON (2) (3)
HART Device ID	It indicates the HRT_ECU1000 Device ID			R	Local
Polling Address	It indicates the HRT_ECU1000 Polling Address	0 – 63	0	RW	Local, Serial, Bus
HART Mode	Not Used.	Loop Enabled, Loop Disabled, Multidrop	Loop Enabled	RW	Local, Serial, Bus
SW Rev Level	It indicates the HRT_ECU1000 Software revision			R	Local, Serial, Bus
HW Rev Level	It indicates the HRT_ECU1000 Hardware revision			R	Local, Serial, Bus



BIFFI ITALIA s.r.l.

Loc. Caselle S. Pietro

29017 Fiorenzuola d'Arda -Piacenza - ITALY -

Tel. (0523) 944411 - Fax (0523) 941885

E_mail: biffi_italia@biffi.it