

Biffi FCBB/FCBA300-Series Pneumatic Valve Actuator

Component Material List



This page intentionally left blank

Table of Contents

Section 1: Major Component Material List

- 1.1 Typical FCBB-Series Major Component Material List..... 1
- 1.2 Typical FCBA300-Series Major Component Material List 3

Section 2: Seal Material List

- 2.1 Typical FCBB/FCBA300-Series Seal Material List 5

Section 3: Typical Coatings

- 3.1 Nitriding 6
- 3.2 Teflon Lined Cylinder Bores..... 6

This page intentionally left blank

Section 1: Major Component Material List

1.1 Typical FCBB-Series Major Component Material List

Figure 1 FCBB-Series Major Components

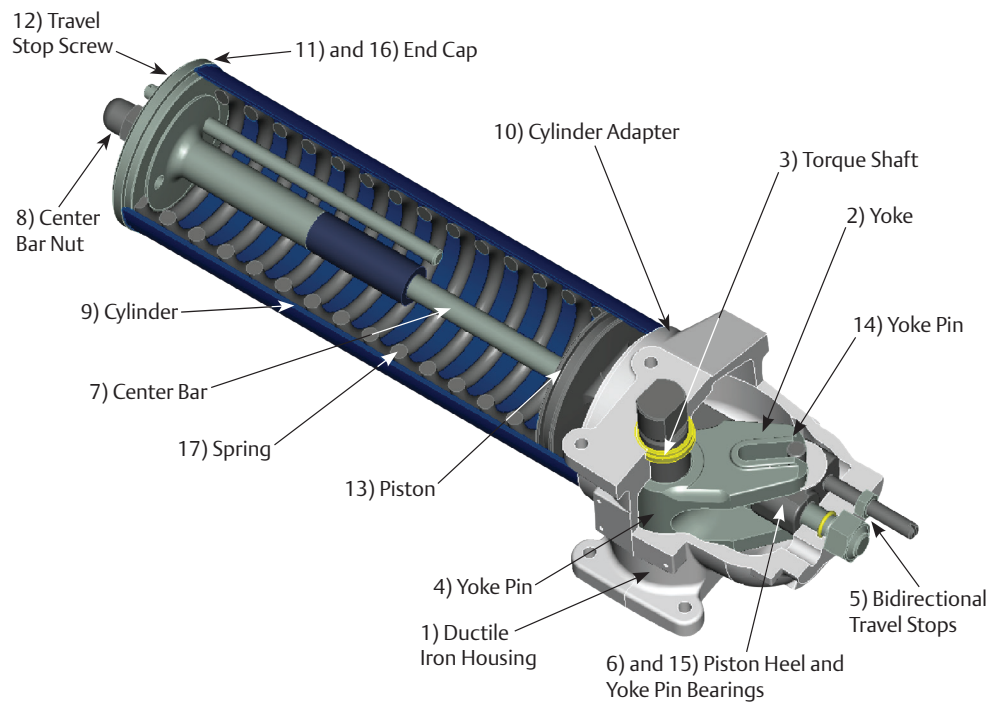

Table 1. Material List

Item	Description	Material	
Housing			
1	Housing	Cast Ductile Iron or Carbon Steel*	ASTM A395 or ASTM A352*
2	Yoke, FCBBx15 and FCBBx20	Cast steel	ASTM A732
	Yoke, FCBBx25	Cast Ductile Iron	ASTM A536
3	Torque shaft	Alloy steel	ASTM A311
4	Yoke key	Steel	ASTM A108
5	Travel stop screw	Alloy steel, Zinc plated	ASTM A193
	Travel stop screw nut	Alloy steel, Zinc plated	ASTM A194
6	Yoke/Yoke pin bearing	UHMWPE plastic	-
7	Center bar	Alloy steel, Nitrided	ASTM A193
8	Center bar nut	Alloy steel, Zinc plated	ASTM A194
Pneumatic Power Cylinder			
9	Cylinder	Steel, TFE lined	ASTM A513
10	Cylinder adapter	Cast Ductile Iron or Steel*	ASTM A395 or ASTM A516*
11	Outer end cap, DA	Steel	ASTM A516
12	Travel stop screw	Alloy steel, Zinc plated	ASTM A193
	Travel stop screw nut	Alloy steel, Zinc plated	ASTM A194
13	Piston, standard	Cast Ductile Iron	ASTM A536
14	Yoke pin	Steel, TFE coated	ASTM A108
15	Piston heel bearing	Steel/Bronze/TFE	Garlock DU Style
Spring Cartridge			
16	Outer end cap, SR	Cast Ductile Iron or Carbon Steel*	ASTM A536 or ASTM A352*
17	Spring	Alloy steel	ASTM A229

NOTE:

* Optional selection

1.2 Typical FCBA300-Series Major Component Material List

Figure 2 FCBA300-Series Major Components

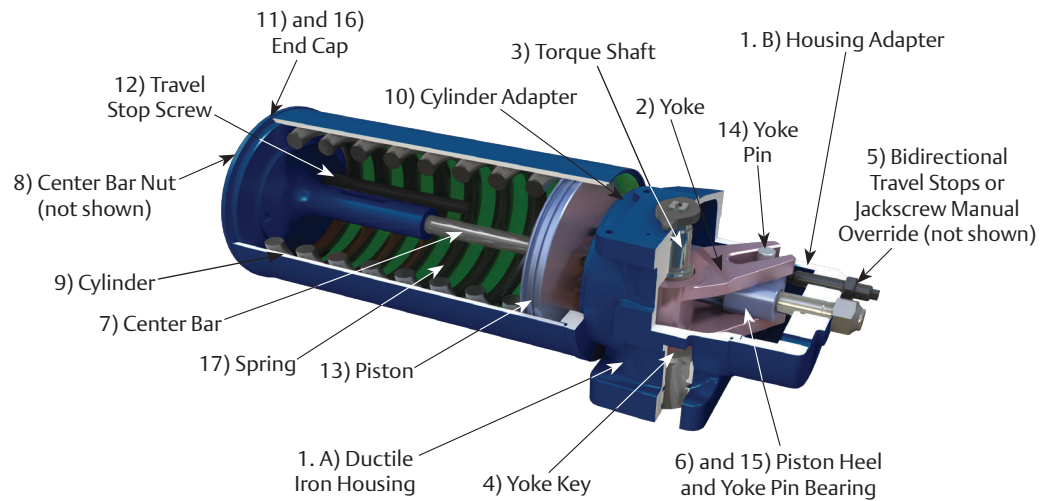

Table 2. Material List

Item	Description	Material	
Housing			
1. A	Housing	Cast Ductile Iron or Carbon Steel*	ASTM A395 or ASTM A352*
1. B	Housing adapter	Cast Ductile Iron or Carbon Steel*	ASTM A395 or ASTM A352*
2	Yoke	Cast Ductile Iron	ASTM A536
3	Torque shaft	Alloy steel, Nitrided	AISI 4140 HT
4	Yoke key	Steel	ASTM A108
5	Travel stop screw	Alloy steel, Zinc plated	ASTM A193
	Travel stop screw nut	Alloy steel, Zinc plated	ASTM A563
6	Yoke/Yoke pin bearing	UHMWPE plastic	-
7	Center bar	Alloy steel, Nitrided	ASTM A193
8	Center bar nut	Alloy steel, Zinc plated	ASTM A194
Pneumatic Power Cylinder			
9	Cylinder	Steel, TFE lined	ASTM A513
10	Cylinder adapter	Steel	ASTM A516
11	Outer end cap, DA	Steel	ASTM A516
12	Travel stop screw	Alloy steel, Zinc plated	ASTM A193
12	Travel stop screw nut	Alloy steel, Zinc plated	ASTM A563
13	Piston	Cast Ductile Iron	ASTM A536
14	Yoke pin	Alloy steel	AISI 4140 HT
15	Piston heel bearing	Steel/Bronze/TFE	Garlock DU Style
	Yoke pin bearing	Steel/Bronze/TFE	Garlock DU Style
	Rod bushing	Acetal plastic	-
	Piston bearing	TFE	-
Spring Cartridge			
16	Outer end cap, SR	Cast Ductile Iron or Carbon Steel*	ASTM A536 or ASTM A352*
17	Spring	Alloy steel	ASTM A689

NOTE:

* Optional selection

Section 2: Seal Material List

2.1 Typical FCBB/FCBA300-Series Seal Material List

Table 3.

Description	Type	Application
Piston OD/Cylinder ID	O-ring/D-ring	Dynamic
Piston/Center bar	O-ring/T-seal	Dynamic
Torque shaft	O-ring	Rotary
All remaining seals	O-ring	Static

Section 3: Typical Coatings

3.1 Nitriding

Biffi utilizes a Nitride surface finish on many component parts instead of Chrome or Nickel plating.

The nitrided surface is not a coating. It is an integral part of the component base material. Because of this, it will not pit, crack, chip, or flake off, and any possibility of hydrogen embrittlement (a common problem in any plating process) is eliminated.

The Nitride surface layer is extremely hard and displays improved wear resistance when compared with plated coatings. Dent resistance is also improved.

The Nitride surface layer has also been shown to display superior corrosion resistance to plated coatings.

Nitride surface finishing has become very popular in the fluid power industry in the past decade replacing chrome and nickel plating in many applications.

Typical components – piston rods, tie bars, FCBB center bars, cylinder bores, pistons.

Typical process results in a thin surface layer of iron oxide over the second layer of porous Iron Nitride over the third layer of non-porous Iron Nitride are all fused on top of the base substrate steel material.

3.2 Teflon Lined Cylinder Bores

The standard coating on all Biffi pneumatic cylinder bores is Xylan, a proprietary Teflon coating.

The use of this Teflon lining results in superior corrosion resistance while improving seal life and overall actuator performance.

This page intentionally left blank

Biffi Italia s.r.l.
Strada Biffi 165
29017 Fiorenzuola d'Arda (PC)
Italy
T +39 0523 944 411

For complete list of sales and manufacturing sites, please visit
www.biffi.it or contact us at biffi_italia@biffi.it

VCIOM-17150-EN (CP-13249) ©2022 Biffi. All rights reserved.

The contents of this publication are presented for information purposes only, and while every effort has been made to ensure their accuracy, they are not to be construed as warranties or guarantees, express or implied, regarding the products or services described herein or their use or applicability. All sales are governed by our terms and conditions, which are available on request. We reserve the right to modify or improve the designs or specifications of our products at any time without notice.

