

Biffi EHO Electro-Hydraulic Operator

The Biffi EHO is a self-contained, quarter-turn, valve actuator that combines proven technologies from Emerson's actuation technologies portfolio. The actuator has been designed for critical shutdown applications where reliability is crucial. The Biffi EHO utilizes a dependable spring-return actuator for the fail-safe stroke combined with an integral hydraulic power pack and electronic control module.

The Biffi EHO accepts a wide range of single-phase, three-phase or DC power sources, solar panels are also available for areas without electrical power. A hydraulic hand pump can be used to stroke the actuator during commissioning or in the event of an emergency power loss.

Electronic modules are contained within an explosion-proof IP68 enclosure and all electronic components are isolated from the customer connection terminals.

Both spring-return and double-acting configurations are available with torque outputs up to 268,868.08 Nm. The Biffi EHO provides a compact design with actuator and control components that have been field proven for decades in critical service applications.

The Biffi EHO is designed for on/off, ESD and modulating ESD applications and comes with alert, alarm, diagnostic and self-calibration features.

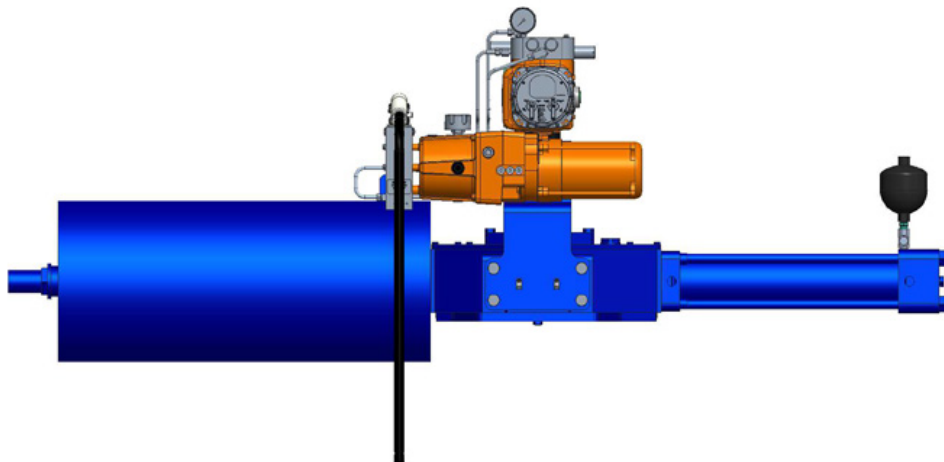

Biffi EHO



This page is intentionally left blank.

Table of Contents

Section 1: Product Attributes

Product Attributes 5

Section 2: General Specifications

General Specifications 6

Section 3: Torque Output Data and Stroking Time

Spring-Return, Fail-Safe Actuator 7

Section 4: Model Code Information

Model Code Information 9

Section 5: Dimensions

Spring-Return, Fail to Close Actuator 13

Spring-Return, Fail to Open Actuator 14

Section 6: Diagrams

Biffi EHO 15

This page is intentionally left blank.

Product Attributes

- Easy Installation – the Biffi EHO actuator is a totally self-contained system and designed for compactness and adaptable to new or existing valves
- Biffi OLGA-H and OLGAS-H hydraulic double-acting or spring-return, fail-safe actuator
- Bettis™ electronics and communication technology
- Multiple input power options with AC
- Local lockable Remote/Local/Offline selector switch
- Local Open/Close selector knob
- Partial stroke test
- Fast speed of operation to fail-safe position if required
- Emergency shutdown – independent safety circuits and solenoid valve
- Dual sealed Separate Terminal Chamber allows installation wiring to be performed or fuses to be replaced without exposing control components to hostile environmental conditions
- Control enclosure is made of low-copper aluminum alloy, powder-coated, salt-resistant and rated for IP68 ingress protection
- Hydraulic hand pump manual override
- Accumulators (optional)
- Operating pressures up to 207 bar with standard components
- Easy control over actuator stroking speeds – The stroking speed is controlled through adjustable hydraulic flow control valves. This enables field personnel to easily adjust actuator stroking speed to comply with field requirements
- Communication support through Modbus®, HART® and FOUNDATION™ Fieldbus (FF)
- Modulating through 4 to 20 mA analog input
- Over 25 alerts and alarms
- Diagnostics and self-calibration features

General Specifications

Input Power (AC)

- Three-phase 50 Hz
 - 220, 230, 240, 380, 400, 440, 460, 480, 500, 550, 575, 600 volts
- Three-phase 60 Hz
 - 208, 220, 230, 380, 440, 460, 480, 575, 600 volts
- Single-phase 50 Hz
 - 110, 115, 220, 230, 240 volts
- Single-phase 60 Hz
 - 115, 120, 208, 220, 230 volts

Input Power (DC)

- 24 volts
- Additional DC motor voltage consult factory

Note: The nominal operating voltage must be specified at time of order. Published actuator performance data is for power supply variations of a $\pm 10\%$ voltage and a ± 5 Hz frequency. If power supply variations are outside these limits, please consult Biffi factory to ensure that actuator performance meets your requirements.

Conduit Entry Sizes

- Three 1 in. NPT
- One 1.5 in. NPT entry

Local Operation and Display

- Open/Close selector knob
- Local/Off/Remote lockable selector switch
- Full color LCD display
- On-screen alarm and alerts display
- Local/Off/Remote position indication on-screen
- Hydraulic hand pump manual override

Remote Operation (Inputs)

- Discrete Open/Close/Stop/ESD signals
- Discrete PST signal
- 4 to 20 mA positioning (1% accuracy)

Remote Operation (Outputs)

- Discrete open/close limits
- 4 to 20 mA hydraulic pressure feedback
- 4 configurable relays
- 1 ESD monitor relay
- 4 to 20 mA position feedback

Operating Temperature

- -20 to +60 °C (standard)
- -40 to +60 °C (low temp optional)
- Contact factory for extended high temperature range

Hydraulic Fluid

- ENI® Arnica 22 (or equivalent)
For temperatures down to -30 °C
- Shell® Aeroshell 41 (or equivalent)
For temperatures down to -40 °C

Ingress Protection

- Control enclosure: IP68
- Hydraulic actuator: IP67M and IP66M
- Motor: IP68
- Reservoir: IP54 (IP66 optional)

Hazardous Area Classification and SIL Certification

- CSA, Canadian Standard Association Certification
 - Class I, Division I, Groups C and D
 - Group B configuration upon request
- Factory Mutual (FM) Certification
 - Class I, Groups C, D and Division I, T4
 - Group B configuration upon request
- ATEX Directive
 - EExd IIB T4
- IECEx Certificate of Conformity
 - Ex d IIB T4
- RoHS Directive

Note: This product is only intended for use in large-scale fixed installations excluded from the scope of Directive 2011/65/EU on the restriction of the use of certain hazardous substances in electrical and electronic equipment (RoHS 2).

- IEC 61508-1 to7:2010 -
Suitable for use in SIL 3 applications

Torque Output Data and Stroking Time

Spring-Return, Fail-Safe Actuator

Table 1. Fail to Close

Spring-Return Model	Actuator MOP (bar)	Actuator Displacement (L)	Spring Cycle (Nm)			Pressure Cycle @ 172 bar (Nm) or designated pressure			Pressure Cycle @ 207 bar (Nm) or designated pressure		
			Spring ETC (Nm)	Spring RUN (Nm)	Spring BTC (Nm)	Pressure BTO @ 172 bar unless indicated (Nm)	Pressure @ 172 bar RUN (Nm)	Pressure ETO @ 172 bar (Nm)	Pressure BTO @ 207 bar (Nm)	Pressure @ 207 bar RUN (Nm)	Pressure ETO @ 207 bar (Nm)
OLGAS/H 0.3S-0150-40-CL	285	0.2	932	438	567	1,446	805	1,206	1,858	1,066	1,678
OLGAS/H 0.9S-0350-60-CL	335	0.5	1,414	1,095	2,335	3,848	2,159	3,277	4,920	2,840	4,503
OLGAS/H 1.5S-1200-85-CL	235	1.1	5,096	3,798	7,315	9,427	4,498	5,439	12,379	6,244	8,287
OLGAS/H 3S-2000-85-CL	275	2.5	8,067	5,779	11,011	15,665	7,940	10,557	20,477	10,826	15,364
OLGAS/H 6S-2500-95-CL	350	2.9	12,005	8,394	15,763	22,580	11,624	15,840	29,610	15,836	22,845
OLGAS/H 6S-3800-110-CL	285	3.9	17,778	11,738	21,163	28,672	15,044	21,106	38,097	20,692	30,498
OLGAS/H 14S-5100-110-CL	350	4.2	21,650	14,096	24,831	29,907	15,136	20,187	40,363	21,321	30,275
OLGAS/H 14S-5400-125-CL	350	5.4	25,890	17,699	32,271	40,659	20,159	26,028	54,161	28,146	39,055
OLGAS/H 14S-8300-145-CL	295	7.3	33,727	22,869	41,468	55,860	28,159	37,328	74,029	38,906	54,857
OLGAS/H 14C-8300-175-CL	200	10.6	48,401	23,616	37,914	90,251 @125 barg	30,781 @125 barg	36,012 @125 barg	118,013 @150 barg	42,016 @150 barg	51,659 @150 barg
OLGAS/H 18S-9800-185-CL	240	13.6	56,517	43,271	84,518	11,1288	52,644	62,698	145,338	72,766	95,468
OLGAS/H 18S-11000-200-CL	220	15.9	74,441	54,866	104,825	121,795	56,803	65,873	161,590	80,321	104,172

Table 2. Fail to Close (continuation)

Spring-Return Model	Actuator MOP (bar)	Actuator Displacement (L)	Oil					Spring	
			3-Phase ⁽¹⁾ @ 400 V AC 50 Hz	1-Phase ⁽¹⁾ @ 230 V AC 50 Hz	Motor Power Size (hp)	DC ^(2,3) 24 V DC 1/2 HP	Fastest stroking time with accumulator ⁽⁴⁾	Fastest SR stroking time to fail position	Slowest recommended SR Stroke time to fail position
			Time Stroke (s)	Time Stroke (s)		Time Stroke (s)	Time Stroke (s)	Time Stroke (s)	Time Stroke (s)
OLGAS/H 0.3S-0150-40-CL	285	0.2	10	10	1	16	C/F	1.5	60
OLGAS/H 0.9S-0350-60-CL	335	0.5	28	28	1	41	C/F	3.0	90
OLGAS/H 1.5S-1200-85-CL	235	1.1	57	57	1	97	C/F	8.0	90
OLGAS/H 3S-2000-85-CL	275	2.5	78	117	1.5	123	C/F	17.0	120
OLGAS/H 6S-2500-95-CL	350	2.9	88	132	1.5	151	C/F	22.0	120
OLGAS/H 6S-3800-110-CL	285	3.9	113	169	1.5	C/F	C/F	25.0	120
OLGAS/H 14S-5100-110-CL	350	4.2	119	179	1.5	C/F	C/F	25.0	120
OLGAS/H 14S-5400-125-CL	350	5.4	158	237	1.5	C/F	C/F	38.0	120
OLGAS/H 14S-8300-145-CL	295	7.3	238	357	1.5	C/F	C/F	60.0	120
OLGAS/H 14C-8300-175-CL	200	10.6	285	427	1.5	C/F	C/F	60.0	120
OLGAS/H 18S-9800-185-CL	240	13.6	500	C/F	1.5	N/A	C/F	133.0	180
OLGAS/H 18S-11000-200-CL	220	15.9	500	C/F	1.5	N/A	C/F	133.0	180

NOTES:

C/F = Consult factory
N/A = Not applicable

- Estimated Stroking speeds will vary with temperature and hydraulic fluid viscosity changes. For stroking speed requirements less than the values proposed in the table, consult factory (additional hydraulic accumulator to decrease opening stroke times can be add).
- If slower stroke time is required, please consult factory.
- Single-phase motors will be 1 hp only.
- If accumulator is required, please consult factory before selecting an actuator size.

Table 3. Fail to Open

Spring-Return Model	Actuator MOP (bar)	Actuator Displacement (L)	Spring Cycle (Nm)			Pressure Cycle @ 172 bar (Nm) or designated pressure			Pressure Cycle @ 207 bar (Nm) or designated pressure		
			Spring ETC (Nm)	Spring RUN (Nm)	Spring BTC (Nm)	Pressure BTO @ 172 bar unless indicated (Nm)	Pressure @ 172 bar RUN (Nm)	Pressure ETO @ 172 bar (Nm)	Pressure BTO @ 207 bar (Nm)	Pressure @ 207 bar RUN (Nm)	Pressure ETO @ 207 bar (Nm)
OLGAS/H 0.3S-0150-40-OP	290	0.2	508	417	835	1,532	807	1,212	1,960	1,070	1,674
OLGAS/H 0.9S-0350-60-OP	320	0.5	1,189	999	2,022	4,150	2,212	3,371	5,266	2,899	4,572
OLGAS/H 1.5S-1200-85-OP	260	1.1	4,100	3,677	8,039	8,210	4,407	6,240	10,800	6,167	9,549
OLGAS/H 3S-2000-85-OP	285	2.5	6,596	5,541	11,645	14,209	7,916	12,037	18,562	10,825	17,442
OLGAS/H 6S-2500-95-OP	350	2.9	9,842	8,016	16,561	20,661	11,658	18,062	27,031	15,905	25,941
OLGAS/H 6S-3800-110-OP	290	3.9	14,994	11,368	22,538	26,084	15,019	23,865	34,626	20,713	34,429
OLGAS/H 14S-5100-110-OP	350	4.2	17,957	13,768	27,596	26,095	14,955	23,264	35,269	21,190	34,983
OLGAS/H 14S-5400-125-OP	350	5.4	21,071	17,120	35,521	35,633	19,983	30,184	47,480	28,036	45,317
OLGAS/H 14S-8300-145-OP	300	7.3	27,394	20,997	45,564	49,074	28,039	43,443	65,015	38,874	63,806
OLGAS/H 14C-8300-175-OP	160	10.6	23,128	19,942	67,393	48,943 @ 125 barg	31,932 @ 125 barg	70,991 @ 125 barg	63,986 @ 150 barg	43,273 @ 150 barg	101,801 @ 150 barg
OLGAS/H 18S-9800-185-OP	265	13.6	43,508	38,132	91,349	82,825	42,118	54,349	109,492	60,271	88,498
OLGAS/H 18S-11000-200-OP	250	15.9	63,684	52,232	119,521	101,925	52,892	70,728	136,755	76,601	115,330

Table 4. Fail to Open (continuation)

Spring-Return Model	Actuator MOP (bar)	Actuator Displacement (L)	Oil					Spring	
			3-Phase ⁽¹⁾ @ 400 V AC 50 Hz	1-Phase ⁽¹⁾ @ 230 V AC 50 Hz	Motor Power Size (hp)	DC ^(2,3) 24 V DC 1/2 HP	Fastest stroking time with accumulator ⁽⁴⁾	Fastest SR stroking time to fail position	Slowest recommended SR Stroke time to fail position
			Time Stroke (s)	Time Stroke (s)		Time Stroke (s)	Time Stroke (s)	Time Stroke (s)	Time Stroke (s)
OLGAS/H 0.3S-0150-40-OP	290	0.2	10	10	1	16	C/F	2	60
OLGAS/H 0.9S-0350-60-OP	320	0.5	28	28	1	41	C/F	3	90
OLGAS/H 1.5S-1200-85-OP	260	1.1	57	57	1	97	C/F	8	90
OLGAS/H 3S-2000-85-OP	285	2.5	78	117	2	123	C/F	17	120
OLGAS/H 6S-2500-95-OP	350	2.9	88	132	2	151	C/F	22	120
OLGAS/H 6S-3800-110-OP	290	3.9	113	169	2	C/F	C/F	25	120
OLGAS/H 14S-5100-110-OP	350	4.2	119	179	2	C/F	C/F	25	120
OLGAS/H 14S-5400-125-OP	350	5.4	158	237	2	C/F	C/F	38	120
OLGAS/H 14S-8300-145-OP	300	7.3	238	357	2	C/F	C/F	60	120
OLGAS/H 14C-8300-175-OP	160	10.6	285	427	2	C/F	C/F	60	120
OLGAS/H 18S-9800-185-OP	265	13.6	500	C/F	2	N/A	C/F	133	180
OLGAS/H 18S-11000-200-OP	250	15.9	500	C/F	2	N/A	C/F	133	180

NOTES:

C/F = Consult factory

N/A = Not applicable

- Estimated Stroking speeds will vary with temperature and hydraulic fluid viscosity changes. For stroking speed requirements less than the values proposed in the table, consult factory (additional hydraulic accumulator to decrease opening stroke times can be add).
- If slower stroke time is required, please consult factory.
- Single-phase motors will be 1 hp only.
- If accumulator is required, please consult factory before selecting an actuator size.

Model Code Information

Table 5. Spring-Return EHO

Code	Product Description	
EHO SA	Smart Self-Contained Electro-Hydraulic Actuator	
Code	Actuator Size	
Spring-Return Actuator Model		
OLGAS/H 0.3S-0150-40	-	
OLGAS/H 0.9S-0350-60	-	
OLGAS/H 1.5S-1200-85	-	
OLGAS/H 3S-2000-85	-	
OLGAS/H 6S-2500-95	-	
OLGAS/H 6S-3800-110	-	
OLGAS/H 14S-5100-110	-	
OLGAS/H 14S-5400-125	-	
OLGAS/H 14S-8300-145	-	
OLGAS/H 14C-8300-175	-	
OLGAS/H 18S-9800-185	-	
OLGAS/H 18S-11000-200	-	
Code	Temperature Rating	
A	-29 °C / -20 °F	
B	-40 °C / -40 °F	
C	-20 °C / -4 °F see certification note	
Code	Valve Rotation Direction	
0	Clockwise to close (counterclockwise to open)	
1	Counterclockwise to close	
Code	Actuator Function	
B	On/Off or Intermittent Positioning	
C	Modulating	
Code	Fail Function	
Loss of Power		Loss of ESD Signal
0	Stay put (No ESD)	N/A
1	Stay put	Close
2	Close	Close
3	Stay put	Open
4	Open	Open
5	Close (No ESD)	N/A
6	Open (No ESD)	N/A
Code	ESD Solenoid Valve (Contact factory to verify compatible functions)	
X	No ESD Solenoid Valve (Fail Function Code 0 only)	
N	Internally Powered ESD Solenoid Valve, No ESD Signal (Fail Function Codes 5 and 6 only, if Low Wattage Required Add -S)	
S	Internal Standard Solenoid Valve, 24 V DC SIGNAL (Fail Function Codes 1, 2, 3, and 4) - Common	
R	Internal Standard Solenoid Valve with External Manual Reset Pushbutton Box, 24 V DC SIGNAL (Fail Function Codes 1, 2, 3, and 4)	
L	External Low Wattage Solenoid Valve (down to -36 °C), 24 V DC SIGNAL (Fail Function Codes 1, 2, 3, and 4)	
D	Dual ESD Solenoid Valves, 24 V DC SIGNAL (Fail Function Codes 1, 2, 3, and 4)	
T	Internal Standard Solenoid Valve, 120 V AC SIGNAL (Fail Function Codes 1, 2, 3, and 4) - Common	
P	Internal Standard Solenoid Valve with External Manual Reset Pushbutton Box, 120 V AC SIGNAL (Fail Function Codes 1, 2, 3, and 4)	
K	External Low Wattage Solenoid Valve (down to -36 °C), 120 V AC SIGNAL (Fail Function Codes 1, 2, 3, and 4)	
E	Dual ESD Solenoid Valves, 120 V AC SIGNAL (Fail Function Codes 1, 2, 3, and 4)	
U	Internal Standard Solenoid Valve, Non-standard Signal Voltage Specified in -S (Fail Function Codes 1, 2, 3, and 4) - Uncommon	
Q	Internal Standard Solenoid Valve with External Manual Reset Pushbutton Box, Non-standard Signal Voltage Specified in -S (Fail Function Codes 1, 2, 3, and 4) - Uncommon	
J	External Low Wattage Solenoid Valve (down to -36 °C), Non-standard Signal Voltage Specified in -S (Fail Function Codes 1, 2, 3, and 4) - Uncommon	
F	Dual ESD Solenoid Valves, Non-standard Signal Voltage Specified in -S (Fail Function Codes 1, 2, 3, and 4) - Uncommon	

NOTE:

From code X to F, contact factory before selecting.

Table 6. Spring-Return EHO (continuation)

Code		Communication Protocols		
1		Modbus (CAM05) (Default)		
2		HART (CAM16)		
3		FOUNDATION Fieldbus (CAM228)		
Code		Limit Switches		
N		No Limit Switches		
A		2 SPDT		
Code		Output		
0		None		
1		Internal pressure transmitter with 4 to 20 mA output for hydraulic pressure monitoring		
2		Internal pressure switch for low pressure alarm		
3		Internal pressure switch for low pressure alarm (accumulator)		
Code		Power Supply (Contact factory)		
		Volts	Phase	Hz
1		208	AC	3
2		230	AC	3
3		460	AC	3
T		460	AC	3
4		575	AC	3
5		380	AC	3
N		380	AC	3
6		115	AC	1
7		208	AC	1
8		230	AC	1
9		415	AC	3
K		220	AC	1
P		220	AC	3
L		115	AC	1
R		550	AC	3
S		660	AC	3
A		400	AC	3
V		690	AC	3
W		690	AC	3
F		24	DC	-
Code		Orientation (Operator to Pipeline)		
		Pipeline Orientation	Valve Stem Orientation	Actuator Cylinder Orientation
1		Horizontal	Vertical	Parallel to pipeline
2		Horizontal	Vertical	Perpendicular to pipeline
3		Horizontal	Horizontal	Parallel to pipeline
4		Horizontal	Horizontal	Perpendicular to pipeline
5		Vertical	Horizontal	Perpendicular to pipeline
6		Vertical	Horizontal	Parallel to pipeline
Code		Valve Mounting		
MN		No Valve Mounting Adaptor		
MA		Valve mounting Adaptor		
Code		Options (Multiple Choices)		
AX		Accumulator for X strokes, for example, A1 means accumulator for 1 stroke		
CB		Close coupled circuit breaker		
PC		Customer specified paint		
PS		Biffi standard paint		
RB		Remote mounted circuit breaker		
RD		Remote display module		
SP		Solar panel and battery (only 24 V DC model)		
SW		Level Switch		
Code		Certificates (Multiple Choices)		
AX		ATEX Eexd IIB T4 Limited to -20 °C / -4 °F		
CS		CSA Class I Div. I Group C, D		
CB		CSA Class I Div. I Group B, C, D		
FM		FM Class I Div. I Group C, D		
FB		FM Class I Div. I Group B, C, D		
IE		IECEX Limited to -20 °C / -4 °F		
S3		SIL 3		
Code		Special Configuration		
S		Special Configuration		

Table 7. Double-Acting EHO

Code	Product Description	
EHO DA	Smart Self-Contained Electro-Hydraulic Actuator	
Code	Actuator	
OLGA-H	Contact factory	
Code	Temperature Rating	
A	-29 °C / -20 °F	
B	-40 °C / -40 °F	
C	-20 °C / -4 °F see certification note	
Code	Valve Rotation Direction	
0	Clockwise to close (counterclockwise to open)	
1	Counterclockwise to close	
Code	Actuator Function	
B	On/Off or Intermittent Positioning	
C	Modulating	
Code	Fail Function	
	Loss of Power	Loss of ESD Signal
0	Stay put (No ESD)	N/A
1	Stay put	Close
2	Close	Close
3	Stay put	Open
4	Open	Open
5	Close (No ESD)	N/A
6	Open (No ESD)	N/A
Code	ESD Solenoid Valve (Contact factory to verify compatible functions)	
X	No ESD Solenoid Valve (Fail Function Code 0 only)	
N	Internally Powered ESD Solenoid Valve, No ESD Signal (Fail Function Codes 5 and 6 only, if Low Wattage Required Add -S)	
S	Internal Standard Solenoid Valve, 24 V DC SIGNAL (Fail Function Codes 1, 2, 3, and 4) - Common	
R	Internal Standard Solenoid Valve with External Manual Reset Pushbutton Box, 24 V DC SIGNAL (Fail Function Codes 1, 2, 3, and 4)	
L	External Low Wattage Solenoid Valve (down to -36 °C), 24 V DC SIGNAL (Fail Function Codes 1, 2, 3, and 4)	
D	Dual ESD Solenoid Valves, 24 V DC SIGNAL (Fail Function Codes 1, 2, 3, and 4)	
T	Internal Standard Solenoid Valve, 120 V AC SIGNAL (Fail Function Codes 1, 2, 3, and 4) - Common	
P	Internal Standard Solenoid Valve with External Manual Reset Pushbutton Box, 120 V AC SIGNAL (Fail Function Codes 1, 2, 3, and 4)	
K	External Low Wattage Solenoid Valve (down to -36 °C), 120 V AC SIGNAL (Fail Function Codes 1, 2, 3, and 4)	
E	Dual ESD Solenoid Valves, 120 V AC SIGNAL (Fail Function Codes 1, 2, 3, and 4)	
U	Internal Standard Solenoid Valve, Non-standard Signal Voltage Specified in -S (Fail Function Codes 1, 2, 3, and 4) - Uncommon	
Q	Internal Standard Solenoid Valve with External Manual Reset Pushbutton Box, Non-standard Signal Voltage Specified in -S (Fail Function Codes 1, 2, 3, and 4) - Uncommon	
J	External Low Wattage Solenoid Valve (down to -36 °C), Non-standard Signal Voltage Specified in -S (Fail Function Codes 1, 2, 3, and 4) - Uncommon	
F	Dual ESD Solenoid Valves, Non-standard Signal Voltage Specified in -S (Fail Function Codes 1, 2, 3, and 4) - Uncommon	
Code	Communication Protocols	
1	Modbus (CAM05) (Default)	
2	HART (CAM16)	
3	FOUNDATION Fieldbus (CAM228)	

NOTE:

From code X to F, contact factory before selecting.

Table 8. Double-Acting EHO (continuation)

Code		Limit Switches		
N		No Limit Switches		
A		2 SPDT		
Code		Output		
0		None		
1		Internal pressure transmitter with 4 to 20 mA output for hydraulic pressure monitoring		
2		Internal pressure switch for low pressure alarm		
Code		Power Supply (Contact factory)		
		Volts	Phase	Hz
1		208	AC	3
2		230	AC	3
3		460	AC	3
T		460	AC	3
4		575	AC	3
5		380	AC	3
N		380	AC	3
6		115	AC	1
7		208	AC	1
8		230	AC	1
9		415	AC	3
K		220	AC	1
P		220	AC	3
L		115	AC	1
R		550	AC	3
S		660	AC	3
A		400	AC	3
V		690	AC	3
W		690	AC	3
F		24	DC	-
Code		Orientation (Operator to Pipeline)		
		Pipeline Orientation	Valve Stem Orientation	Actuator Cylinder Orientation
1		Horizontal	Vertical	Parallel to pipeline
2		Horizontal	Vertical	Perpendicular to pipeline
3		Horizontal	Horizontal	Parallel to pipeline
4		Horizontal	Horizontal	Perpendicular to pipeline
5		Vertical	Horizontal	Perpendicular to pipeline
6		Vertical	Horizontal	Parallel to pipeline
Code		Valve Mounting		
MN		No Valve Mounting Adaptor		
MA		Valve mounting Adaptor		
Code		Options (Multiple Choices)		
AX		Accumulator for X strokes, for example, A1 means accumulator for 1 stroke		
CB		Close coupled circuit breaker		
PC		Customer specified paint		
PS		Biffi standard paint		
RB		Remote mounted circuit breaker		
RD		Remote display module		
SP		Solar panel and battery (only 24 V DC model)		
SW		Level Switch		
Code		Certificates (Multiple Choices)		
AX		ATEX Eexd IIB T4 Limited to -20 °C / -4 °F		
CS		CSA Class I Div. I Group C, D		
CB		CSA Class I Div. I Group B, C, D		
FM		FM Class I Div. I Group C, D		
FB		FM Class I Div. I Group B, C, D		
IE		IECEX Limited to -20 °C / -4 °F		
Code		Special Configuration		
S		Special Configuration		

Dimensions

Spring-Return, Fail to Close Actuator

Figure 1. Spring-Return, Fail to Close Actuator Assembly Drawing

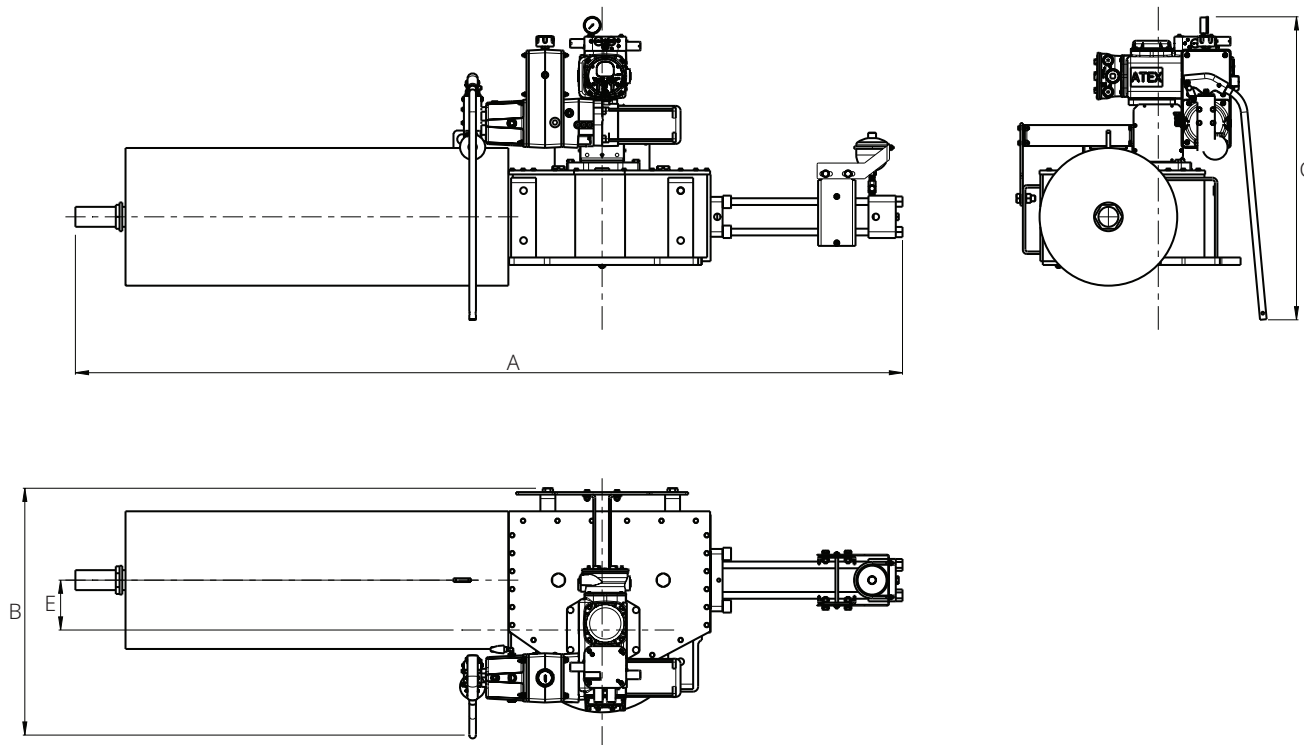

Table 9. Outline Dimensions and Details

Spring-Return Model Fail Close	A (mm)	B (mm)	C (mm)	E (mm)	Weight (kg)
OLGAS/H 0.3S-0150-40-CL	1,288	690	1,260	70	394
OLGAS/H 0.9S-0350-60-CL	1,526	1010	1,260	83	507
OLGAS/H 1.5S-1200-85-CL	1,800	726	1,260	100	661
OLGAS/H 3S-2000-85-CL	2,356	816	1,260	160	938
OLGAS/H 6S-2500-95-CL	3,004	925	1,260	185	1,155
OLGAS/H 6S-3800-110-CL	3,252	925	1,260	185	1,684
OLGAS/H 14S-5100-110-CL	3,366	1,005	1,260	200	1,900
OLGAS/H 14S-5400-125-CL	3,307	1,005	1,260	200	1,985
OLGAS/H 14S-8300-145-CL	3,456	1,005	1,260	200	2,095
OLGAS/H 14C-8300-175-CL	3,460	1,005	1,260	200	2,175
OLGAS/H 18S-9800-185-CL	4,100	1,035	1,260	230	3,320
OLGAS/H 18S-11000-200-CL	4,136	1,035	1,260	230	3,855

NOTE:

B and C are with lever always included.

Spring-Return, Fail to Open Actuator

Figure 2. Spring-Return, Fail to Open Actuator Assembly Drawing

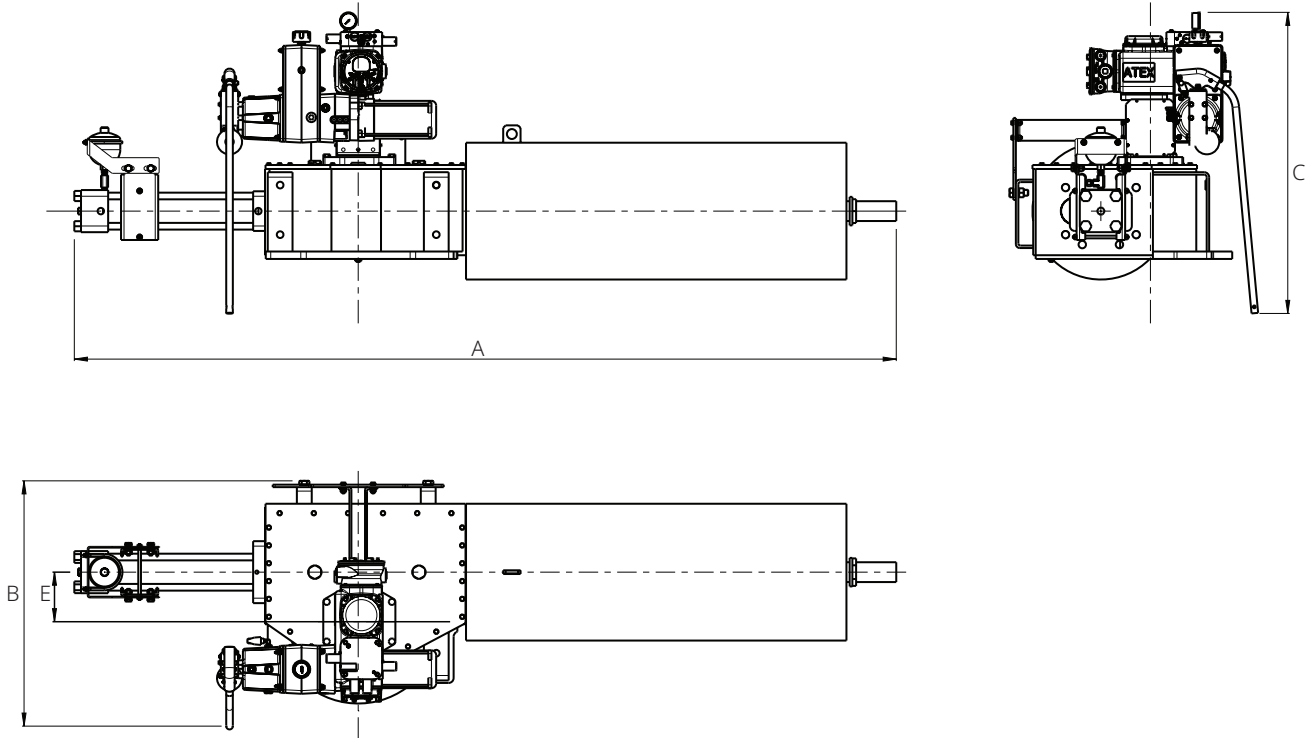

Table 10. Outline Dimensions and Details

Spring-Return Model Fail Open	A (mm)	B (mm)	C (mm)	E (mm)	Weight (kg)
OLGAS/H 0.3S-0150-40-OP	1,288	690	1,260	70	394
OLGAS/H 0.9S-0350-60-OP	1,526	1010	1,260	83	507
OLGAS/H 1.5S-1200-85-OP	1,800	726	1,260	100	661
OLGAS/H 3S-2000-85-OP	2,356	816	1,260	160	938
OLGAS/H 6S-2500-95-OP	3,004	925	1,260	185	1,155
OLGAS/H 6S-3800-110-OP	3,252	925	1,260	185	1,684
OLGAS/H 14S-5100-110-OP	3,366	1,005	1,260	200	1,900
OLGAS/H 14S-5400-125-OP	3,307	1,005	1,260	200	1,985
OLGAS/H 14S-8300-145-OP	3,456	1,005	1,260	200	2,095
OLGAS/H 14C-8300-175-OP	3,460	1,005	1,260	200	2,175
OLGAS/H 18S-9800-185-OP	4,100	1,035	1,260	230	3,320
OLGAS/H 18S-11000-200-OP	4,136	1,035	1,260	230	3,855

NOTE:

B and C are with lever always included.

Diagrams

Biffi EHO

Figure 3. Electrical Connection Diagram

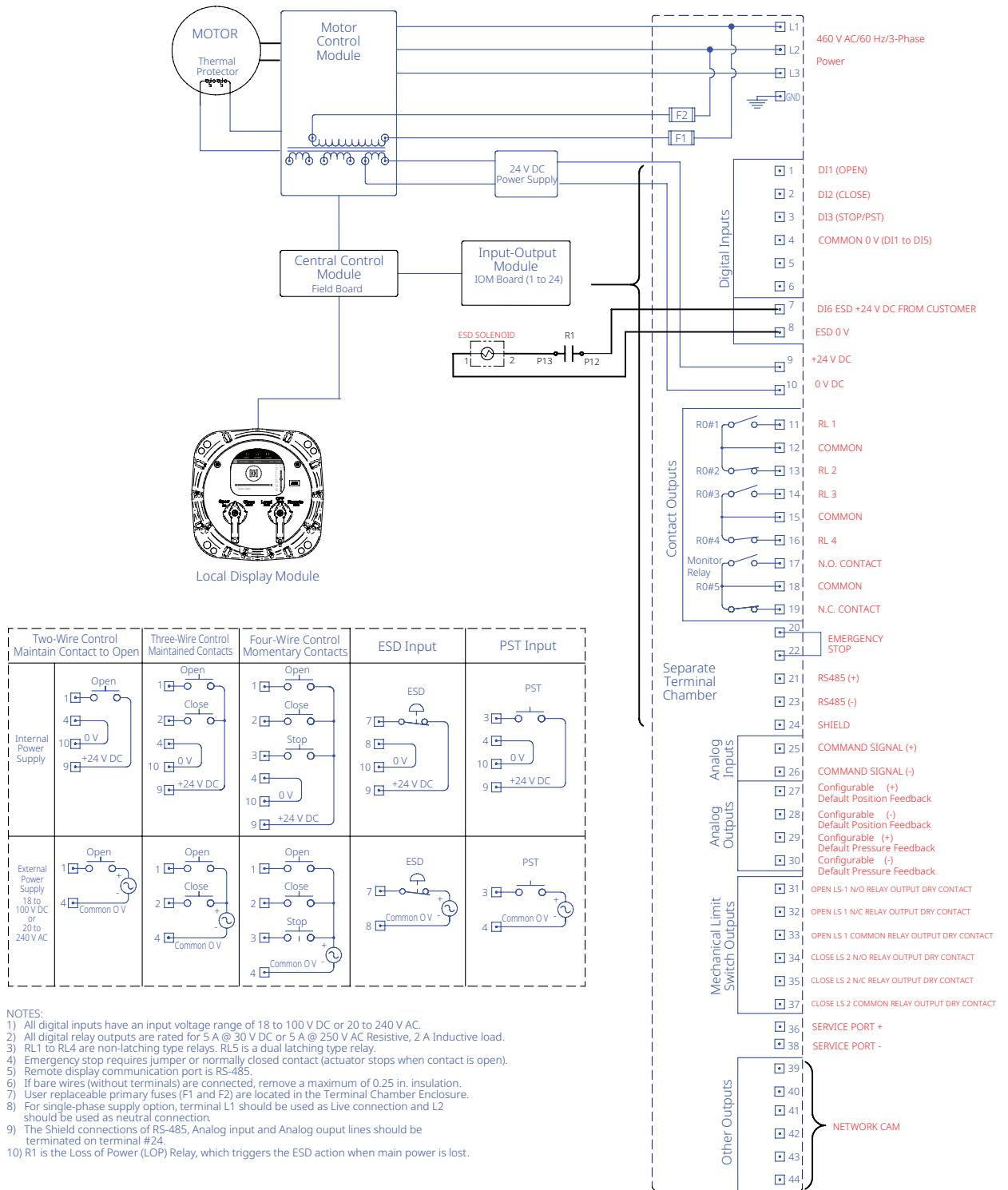

Table 11. Terminal Assignment Based on Network Interface Type

Network Interface Type	Terminal Number	Signal Description
Modbus	39	Channel A +
	40	Shield
	41	Channel A -
	42	Shield
	43	Channel B +
	44	Channel B -
HART	41	Output +
	42	Output -
	43	Input +
	44	Input -
FOUNDATION Fieldbus	42	Shield
	43	FIELDBUS +
	44	FIELDBUS -

NOTE:

If the HART interface cable has Shield connection, the Shield should be connected to Terminal #24.

This page is intentionally left blank.

Biffi Italia s.r.l.
Strada Biffi 165
29017 Fiorenzuola d'Arda (PC)
Italy
T +39 0523 944 411

For complete list of sales and manufacturing sites, please visit
www.biffi.it or contact us at biffi_italia@biffi.it

VCPDS-17034-EN (CP-13426) © 2022, 2024 Biffi. All rights reserved.

The contents of this publication are presented for informational purposes only, and while every effort has been made to ensure their accuracy, they are not to be construed as warranties or guarantees, express or implied, regarding the products or services described herein or their use or applicability. All sales are governed by our terms and conditions, which are available upon request. We reserve the right to modify or improve the designs or specifications of such products at any time without notice.

