

## ECU1000 ELECTRONIC CONTROL UNIT

An advanced electronic system capable to be integrated in a SMART Electro Hydraulic System for heavy modulating, stepping, PST, diagnostic and ESD/BDV actions



### FEATURES

- Standard functions:
  1. Positioning of modulating actuator (heavy duty, low drain-heavy duty, stepping)
  2. Control of integral HPU with single or dual pump. Automatic switch of electrical pumps
  3. Control of on-off actuator
  4. Partial Stroke Test
  5. Input characterization
  6. Failsafe function
  7. ESD function
  8. Stay in position by optional SOV
  9. Outputs to control Servovalves, Proportional Valves, on-off Solenoid Operated Valves (SOV's), contactors of Electrical Motor of hydraulic pumps
  10. Inputs to read 4-20mA transmitters and switches
  11. Optional module to drive proportional valves by PWM signals
- Functions on demand :
  - Process PID, Interlock controls, Process valve watching
  - Hardwired and BUS remote control
  - Local control
  - Local Operator Interface with graphic OLED display and pushbuttons, visible from -40°C
  - User friendly navigation in the menu. English language menu.
  - Diagnostic function
  - Full local parameterization.
  - Access to parameter protected by four levels of password
  - Configuration data saved in 3 separated permanent memories
  - 2 Watch-dog timer working in parallel
  - Real Time Clock and battery to maintain date and time
  - CRC function to validate communication messages and memory content
  - Bluetooth wireless communication
  - Temperature, humidity and acceleration sensors of electronic cards
  - Electronic NAME PLATE of electronic cards
  - Failure, Alarm, Event, Connection loggers, graph and recorder
  - BIFFI-Assistant, SW tool for PC for connection to actuator via Bluetooth or RS232

### GENERAL APPLICATION

ECU1000 is a control unit designed to grant hydraulic (PowerUnit and System) control in oil and gas, petrochemical or power plant. This electronic device is used for the control of any Biffi single and double acting high pressure actuators, suitable for heavy duty modulating and on/off service.

### STANDARD AND APPROVALS

- EMI test according to European directive 2004/108/EC
- Low voltage test according to European directive 2006/95/EC
- Vibration test according to IEC 60068-2-6 and 60068-2-57
- Temperature test according to IEC 60068-2-1, 60068-2-2 and 60068-2-78
- Cabinet IP 65 or Explosion proof ATEX Ex-d IIB

### TECHNICAL DATA

Operating temperature from -40 °C to +75 °C

# ECU1000 ELECTRONIC CONTROL UNIT

## PRODUCT OVERVIEW

### ECU1000 CABINETS



IP65 cabinet



ATEX Ex-d IIB cabinet

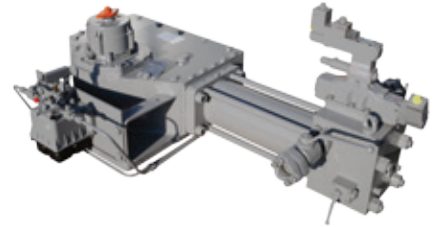

High pressure hydraulic actuator

#### The cabinet contains

- ECU1000 electronic cards
- Power supply module
- Line filter, fuse, surge arrester, breaker
- Terminals for connection with control room, HA, HPU, HCU
- Optional Heater

#### 1.1 Inputs and Outputs

##### Analog inputs

5 x 4-20mA analog inputs, insulating amplifiers and surge arresters

##### Analog output

1 x 4-20mA analog output, insulating amplifier and surge arresters

##### Servo valve / proportional valve control

1 x analog output configurable by jumpers, insulating amplifier and surge arresters, dither

- +-10V, +-10mA, +-15mA, +-50mA, +-100mA
- 1 x digital output, optocoupled, surge arrester
- enable control to servo valve / proportional valve or general output
- 1 x digital input, optocoupled, surge arrester
- fault status of servo valve / proportional valve or general input

##### Digital inputs

10 x digital inputs, optocoupled, max voltage 30Vdc, surge arresters

##### Digital output

1 x digital outputs, optocoupled, surge arresters

##### Output relays

- 4 x single side stable, SPDT contact, voltage free, max 30Vdc/230Vac/1A
- 5 x single side stable, SPST NO contact, voltage free, max 30Vdc/230Vac/1A,
- 2 x single side stable, SPST NO contact, voltage free, max 30Vdc/230Vac/1A (on demand latching relay)

##### Extension connector

It allows increasing the number of I/O's and connection to optional driver card

- optional card with 2 PWM channel e 2 analog inputs to drive 2 BIFFI Proportional Solenoid Operated Valves "PSOV's" or generic proportional valve with PWM control input

Each input and output is configurable and can be associated either to signals to/from control room or HA, HCU, HPU.



Local display



Control cabinet

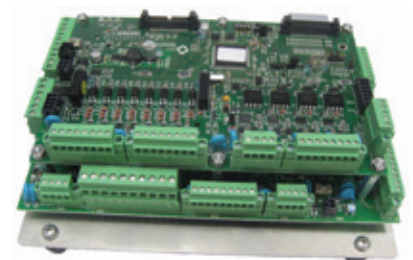

ECU1000 electronic cards

## 1.2 Status signalling

According to NAMUR NE107 the ECU1000 provides the following outputs:

- Failure
- Alarm (out of spec)
- Remote not available (function check)
- Maintenance required

The above statuses are available to the control room by means of output relays and locally by the ECU1000 Local Operator Interface. By the configuration options the conditions associated to output relays can be changed.

8 outputs are provided on the local operator interface to drive 8 optional LED's for local signalling. The status associated to the additional LED's is configurable.

# ECU1000 ELECTRONIC CONTROL UNIT

## ACTUATOR FOR HEAVY MODULATING SERVICE AND LOW OIL DRAIN

Main features:

- Failsafe by spring or accumulator
- Quarter turn or linear
- Integral HPU with single or dual motor pump, or separated HPU
- Proportional PSOV "Biffi design".
- Very low oil drain in off state
- PWM driver card to control the Biffi PSOV's
- ESD function and Fast operation by optional dedicated SOV's
- Standard hardwired or BUS remote control

The figures below show the operating principle.

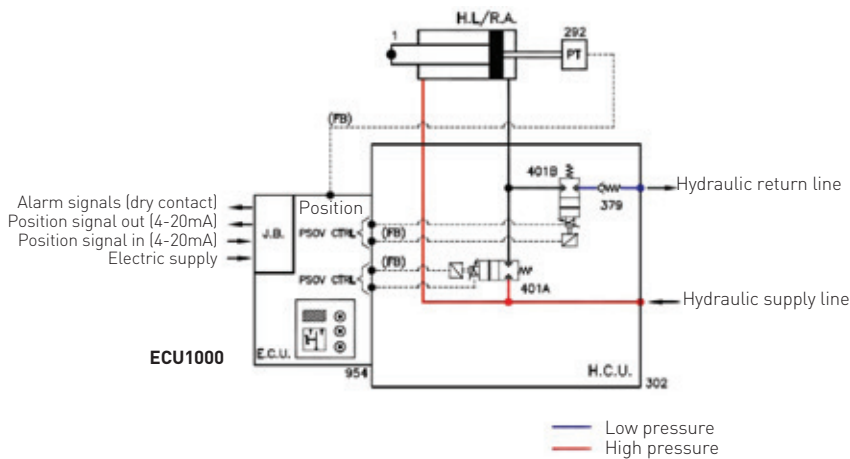

Double acting actuator for heavy modulating service, stay in position in case of loss of electrical power

### PARTS LIST

1	Double acting hydraulic linear actuator
292	Position transmitter
302	Panel
379	Check valve
401	2/2 N.C. poppet type prop. valve with spool pos. transducer
954	Main control unit enclosure

H.L./R.A.: Hydraulic lin./rot. actuator

H.C.U.: Hydraulic control unit

E.C.U.: Electronic control unit

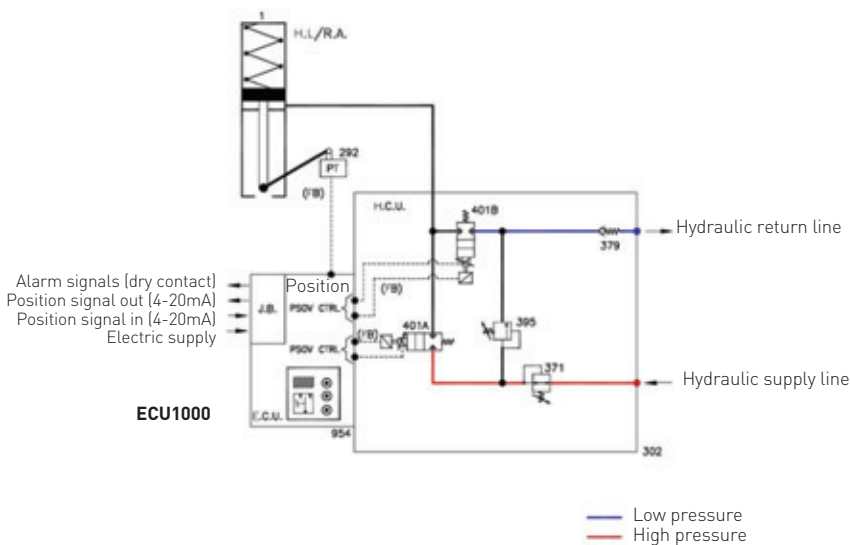

Single acting spring return actuator for heavy modulating service, stay in position in case of loss of electrical power

### PARTS LIST

1	Single acting hydraulic linear actuator
292	Position transmitter
302	Panel
371	Hydraulic pressure regulator
379	Check valve
395	Relief valve
401	2/2 N.C. poppet type prop. valve with spool pos. transducer
954	Main control unit enclosure

H.L./R.A.: Hydraulic lin./rot. actuator

H.C.U.: Hydraulic control unit

E.C.U.: Electronic control unit

# ECU1000 ELECTRONIC CONTROL UNIT

## 2 ACTUATOR FOR STEPPING MODULATING SERVICE

Main features:

- Failsafe by spring or accumulator
- Quarter turn or linear
- Integral HPU with single/dual motor pump, or separated HPU
- On-off Solenoid Operated Valves (SOV's) control

- Stepping modulating service with optional "fast/slow speed" SOV
- Hardwired or BUS remote control
- Optional PST function

The figures below show the operating principle

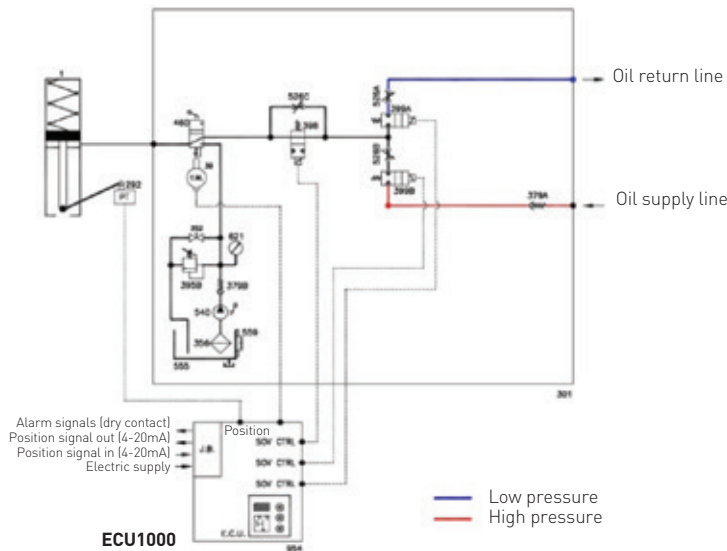

### PARTS LIST

1	Single acting spring return hydraulic actuator
39	Signalling microswitch
292	Electric position transmitter
302	Panel
352	Needle valve
356	Hydraulic filter
379	Check valve
398	2/2 N.O. poppet type solenoid valve
399	2/2 N.C. poppet type solenoid valve
526	Bidirectional flow regulator (adjustable setting)
540	Handpump
555	Oil tank
559	Level gauge
621	Pressure gauge
954	Main control unit enclosure

E.C.U.: Electronic control unit

Single acting spring return actuator for modulating service, two SOV's to open/close the actuator, one fast/slow speed SOV, manual pump with selector.

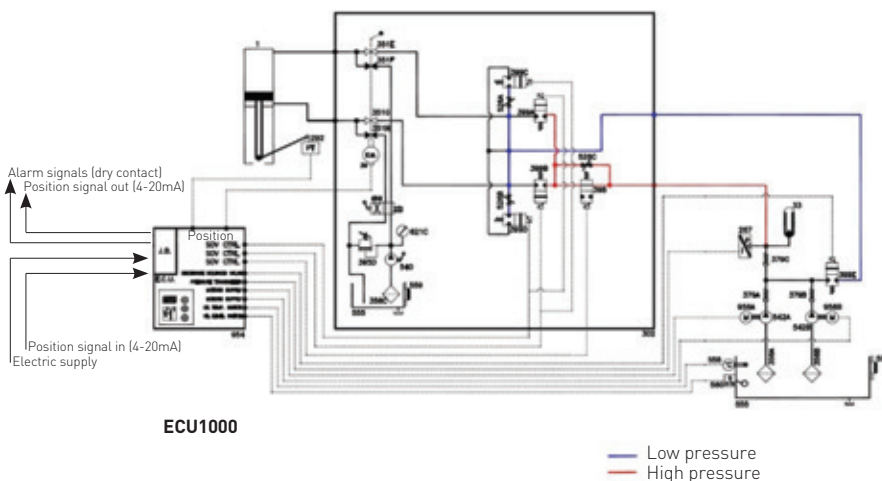

### PARTS LIST

1	Double acting hydraulic linear actuator
33	Hydraulic accumulator (bladder type)
39	Signalling microswitch
267	Pressure transmitter
292	Position transmitter
302	Panel
351	Stop valve
356	Hydraulic filter
379	Check valve
395	Relief valve
398	2/2 N.O. poppet type solenoid valve
399	2/2 N.C. poppet type solenoid valve
484	4/2 hand actuated valve
526	Bidirectional flow regulator (adjustable setting)
540	Handpump
542	Hydraulic rotating pump
555	Oil tank
558	Electric temperature switch
559	Level gauge
560	Electric level switch
621	Pressure gauge
954	Main control unit enclosure
956	Electric motor

E.C.U.: Electronic control unit

Double acting actuator for modulating service, four SOV's to open/close the actuator and one fast/slow speed SOV, integral HPU with dual motor pump, manual pump, manual pump

# ECU1000 ELECTRONIC CONTROL UNIT

## 3 ACTUATOR FOR ON-OFF SERVICE

Main features:

- Failsafe by spring or accumulator
- Quarter turn or linear
- Integral HPU with single/dual motor pump, or separated HPU
- On-off Solenoid Operated Valves (SOV's) control
- On-off service
- Hardwired or BUS remote control
- ESD function by optional dedicated SOV
- Optional PST function

The figures below show the operating principle

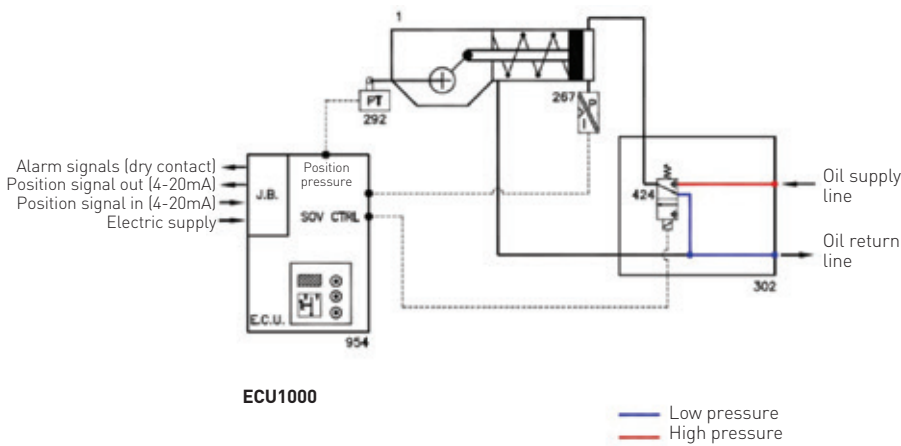

Single acting spring return actuator for ON-OFF service, pressure transmitter for Partial Stroke Test, one SOV to open and close the actuator

### PARTS LIST

1	Single acting spring return hydraulic actuator
267	Pressure transmitter
292	Position transmitter
302	Panel
424	3/2 N.C. poppet type solenoid valve
954	Main control unit enclosure

E.C.U.: Electronic control unit

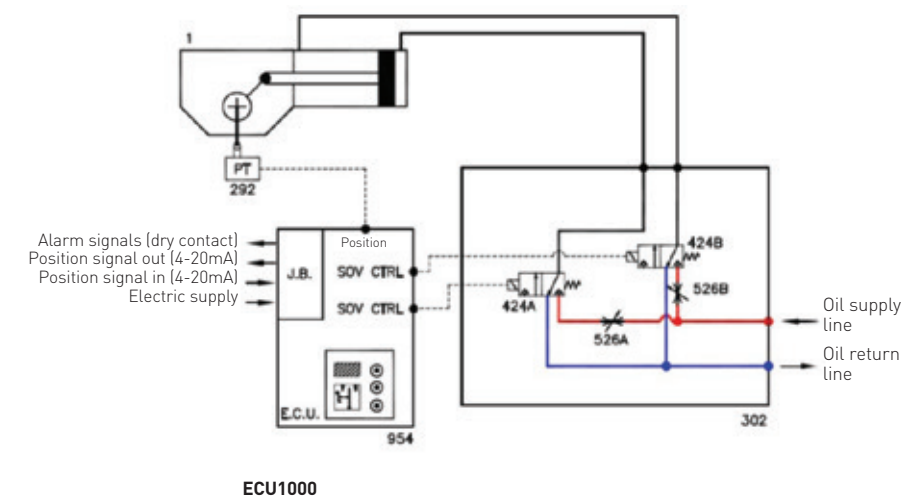

Double acting actuator for ON-OFF service, two SOV's to open and close the actuator. Additional on-off SOV's and pressure transmitter can be added for emergency operation or Partial Stroke Test.

### PARTS LIST

1	Double acting hydraulic actuator
292	Position transmitter
302	Panel
424	3/2 N.C. poppet type solenoid valve
526	Bidirectional flow regulator (adjustable setting)
954	Main control unit enclosure

E.C.U.: Electronic control unit

# ECU1000 ELECTRONIC CONTROL UNIT

## 4 HYDRAULIC POWER UNIT HPU

The HPU gives the hydraulic power requested to move the "actuator + valve" system. It consists in electrical motor, hydraulic pump, reservoir, sensors, manual pump, check valves, oil filter etc. Through its analog and digital inputs and outputs, the ECU1000 controls the oil pressure, monitors the HPU status, drives

the electrical motors, generates alarm in case of malfunction, controls the cycle and switching conditions in case of dual redundant pump. The figures below show the basic diagram of an HPU for modulating and on-off actuator.

INTEGRAL HPU WITH DUAL MOTOR

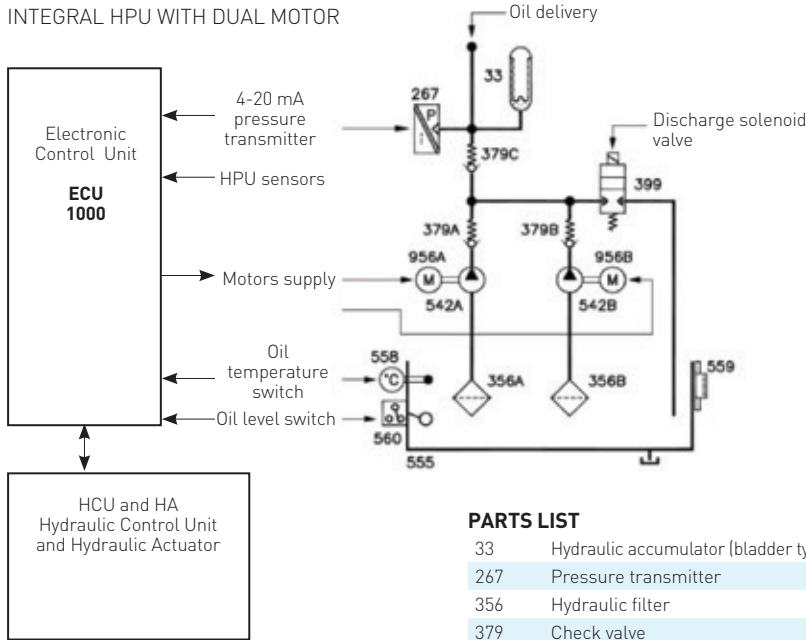

**PARTS LIST**

33	Hydraulic accumulator (bladder type)
267	Pressure transmitter
356	Hydraulic filter
379	Check valve
399	2/2 N.C. poppet type solenoid valve
542	Hydraulic rotating pump

INTEGRAL HPU FOR ON-OFF ACTUATOR

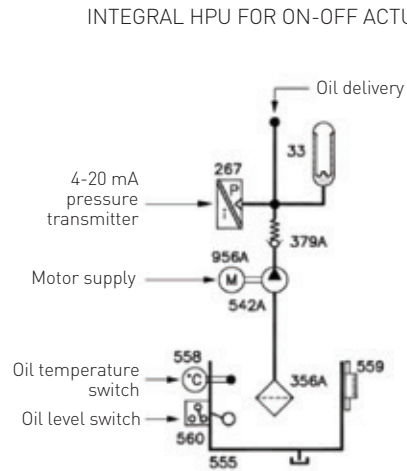

555	Oil tank
558	Electric temperature switch
559	Level gauge
560	Electric level switch
956	Electric motor

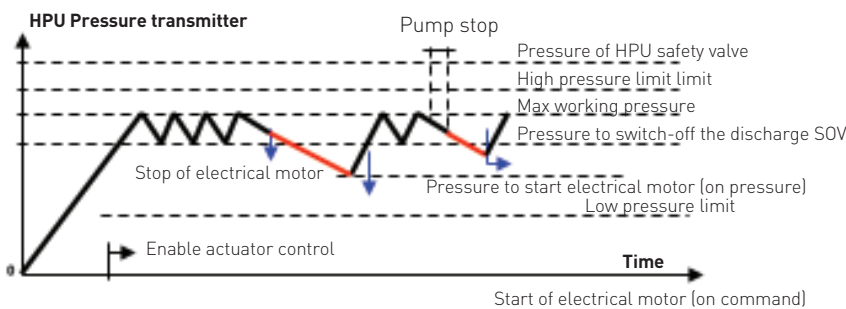

The figure shows the control of HPU pressure for actuator in modulating service. The HPU pressure is measured by a 4-20mA transmitter.

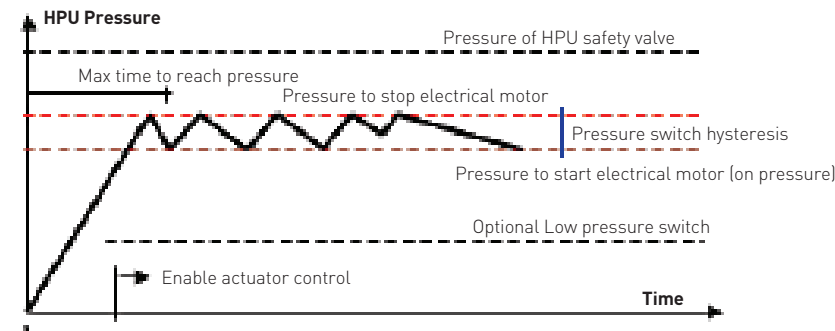

Additional sensors (oil level switch, oil temperature switch, motor thermostat, motor supply on, clogged filter, manual pump switch, etc.) can be added to monitor the HPU operation and signal to control room in case of malfunction.

The figure shows the control of HPU pressure for actuator in on-off service. The HPU pressure is measured by a pressure switch.



Biffi reserve the the right to change product designs and specifications without notice.

**Biffi Italia S.r.L.**

Località Caselle San Pietro, 420, 29017 Fiorenzuola d'Arda (PC) ITALY Ph: +39 (0)523 944 411 E-mail: [biffi\\_italia@biffi.it](mailto:biffi_italia@biffi.it) [www.biffi.it](http://www.biffi.it)