

Biffi F01-3000

Electric Actuator



This page is intentionally left blank

Table of Contents

Section 1: General Safety Instructions

1.1	Range of Application	1
1.2	Safety Instructions for Installation in Hazardous Area.....	1
1.2.1	Marking.....	2
1.3	Applicable Standards and Regulations	2
1.4	Terms and Conditions.....	3

Section 2: Storage and Pre-Installation

2.1	Tests to be Carried Out When the Actuator is Received	4
2.2	Storage Procedure.....	4
2.2.1	General	5
2.2.2	Short-term Storage (One Year or Shorter)	5
2.2.3	Long-term Storage (More Than One Year).....	6
2.3	Checks to be Performed Before Installation.....	6

Section 3: Installation

3.1	Working Condition.....	7
3.1.1	Heater Options	8
3.2	Coupling Block: Disassembly from the Actuator	9
3.3	Manual Operation.....	11
3.4	Mounting the Actuator onto the Valve.....	11
3.5	Electrical Connections.....	12
3.5.1	Identification of Entries.....	13
3.5.2	Plants Requirements	14
3.6	Removing the Electrical Enclosures' Covers.....	14
3.6.1	Terminal Board Enclosure	14
3.7	Cable Entries	15
3.8	Terminal Board	16
3.9	Instructions for the Explosion-Proof Enclosures	20
3.10	Installation in Environment with Explosive Dusts.....	21

Section 4: Lubrication

4.1	Lubrication Inspection.....	22
-----	-----------------------------	----

Section 5: Operating the F01-3000

5.1	Operation by Handwheel	23
5.2	Setting of Mechanical Stops	24
5.3	Electrical Operation	26
5.4	Local Control	26
5.5	Local Indication	27
5.6	Lock of the 3-Position Selector	29
5.7	Remote Control	29
5.7.1	Remote Commands	29
5.7.2	Output Contacts	32
5.7.3	ESD Operation	32
5.7.4	ESD Operation	33
5.7.5	Interlock Inputs	33
5.8	Operating the F01-3000 for the First Time	35
5.9	Optional Modules	35
5.9.1	Fieldbus Interface for Remote Control via Fieldbus	36
5.9.2	Ain/Aout Card	36
5.10	Base Card of the F01-3000	39

Section 6: Local Controls

6.1	Description of the Local Operator Interface	42
6.2	Configuration Options	47
6.3	Entering the View Mode	50
6.4	Entering the Set-Up Mode	50
6.5	Exit from View and Set-Up Mode	51

Section 7: Set-Up Menu

7.1	Set-Up Menu	53
-----	-------------------	----

Section 8: View Menu

8.1	View Menu	55
-----	-----------------	----

Section 9: Set-Up Routines

9.1	Actuator Set-Up	57
9.1.1	Set Stroke Limits	57
9.1.2	Torque Set-Up	59
9.1.3	ESD Control	59
9.1.4	Remote Controls	61
9.1.5	Local Controls	61
9.1.6	Output Relays	62
9.1.7	Positioner	67
9.1.8	Fail-safe	70
9.1.9	Out 4 to 20 mA	71
9.1.10	Interlock	72
9.1.11	2-Speed Timer	72
9.1.12	BUS (or FDI Control)	74
9.1.13	Miscellaneous	74
9.2	Valve Data	77
9.2.1	Sample Configuration Procedure	78

9.3	Maintenance	78
9.3.1	Set Password	79
9.3.2	Clear Alarm Log	79
9.3.3	Set Torque Reference	79
9.3.4	Set Curve Reference	80
9.3.5	Clear Recent Data Log.....	80
9.3.6	Configuration (Backup/Restore).....	81
9.3.7	Set PST Reference	82
9.3.8	PST Command	82
9.3.9	Set Maintenance Date.....	83
9.3.10	Set Data Logger	84
9.4	Example of Set-Up Routine.....	85
9.4.1	Torque Set-Up	85

Section 10: View Routines

10.1	Actuator Set-Up.....	86
10.2	Nameplate	87
10.3	Valve Data	88
10.4	Maintenance	88
10.4.1	Alarm Log.....	88
10.4.2	Torque Profile.....	89
10.4.3	Torque Curve.....	90
10.4.4	Operation Log.....	91
10.4.5	Maintenance Date.....	94
10.4.6	Data Logger.....	94
10.5	Example of View Routine.....	97
10.5.1	View Torque Set-Up	97

Section 11: Maintenance

11.1	Standard Maintenance	98
11.2	Special Maintenance	100
11.3	Lithium Battery Change.....	100

Section 12: Troubleshooting

12.1	The Electronics Do Not Switch on When Powered.....	104
12.2	DC Output Voltage Not Available at the Terminals	105
12.3	The Actuator Does Not Work from Remote Controls	105
12.4	The Motor is Very Hot and Does Not Start.....	106
12.5	The Motor Runs But the Actuator Does Not Move the Valve.....	106
12.6	The Valve Does Not Seat Correctly.....	106
12.7	Excessive Torque for Valve Operation.....	106
12.8	The Actuator Does Not Stop in Fully Open or Fully Closed Position	107
12.9	The Numeric Position Display Indicates "E01"	107
12.10	Diagnostic Messages	107

Section 13: Parts List and Drawings

13.1	Introduction	111
------	--------------------	-----

This page is intentionally left blank

Section 1: General Safety Instructions

1.1 Range of Application

F01-3000 electric actuators covered in this Installation, Operation and Maintenance Manual are designed for the operation of industrial valves used in heavy industrial, chemical and petrochemical plants. Biffi will not be liable for any possible damage resulting from use in other than the designated applications. Such risk lies entirely with the user.

The noise emitted by the electric actuator in normal working conditions is less than 66 dB (A) with peak value 115 dB (C). Standard reference ISO 11202 (1st ed., 1995-12-15).

WARNING

It is assumed that the installation, setting, commissioning, maintenance and repair works are carried out by qualified personnel and checked by responsible specialists.

The electric actuators are designed in accordance with the applicable international rules and specifications but the following regulations must be observed in any case:

- The general installation and safety regulations.
- The plant specific regulations and requirements.
- The proper use of personal protective devices (glasses, clothing, gloves).
- The proper use of tools, lifting and transport equipment.

1.2 Safety Instructions for Installation in Hazardous Area

WARNING

In case the electric actuator must be installed in a HAZARDOUS AREA, as defined by the local rules, it is mandatory to check if the nameplate of the electric actuator specifies the appropriate degree of protection. Maintenance and repair works must be carried out by qualified personnel and checked by responsible specialists.

Electric actuators F01-3000 have been designed and manufactured according to 2014/34/EU Directive. Different types of protections are available, depending on the marking printed on the actuator label: Ex d e IIB Txx and Ex tb Txx with "Explosion-proof" terminal board enclosure or Ex d e IIB Txx and Ex tb Txx with "Increased safety" terminal board enclosure. They are suitable for use in hazardous area classified against the risk of explosion due to the presence of gas and dust.

Actuators have IP68 degree of protection according to EN 60529.

1.3.1 Marking

IECEX INE XX.ZZZZ	IECEX reference certificate (CoC)
XX ATEX ZZZZ	ATEX reference certificate
0080	Notified body for ATEX quality assurance (INERIS)
II	Group II (surface industries)
2	Category 2 apparatus
G	Explosive atmospheres caused by gas, mists or vapors
D	Explosive atmospheres caused by gas dusts
IP66/68	Degree of protection

Table 1. Equipment Protection Level (EPL) EN 60079-14

Explosive Atmosphere	Zone	EPL
Gas, mists or vapors	0	1G
Gas, mists or vapors	1	2G or 1G
Gas, mists or vapors	2	3G, 2G or 1G
Dust	20	1D
Dust	21	2D or 1D
Dust	22	3D, 2D or 1D

1.3 Applicable Standards and Regulations

EN ISO 12100-1	Safety of machinery - Basic concepts, general principles for design. Part 1 - Basic terminology, methodology
EN ISO 12100-2	Safety of machinery - Basic concepts, general principles for design. Part 2 - Technical principles and specification
EN 60204-1	Safety of machinery - Electrical equipment of industrial machines
2006/42/EC	Machinery Directive
2014/35/EU	Low Voltage Directive
2014/30/EU	EMC Directive
2014/34/EU	ATEX Directive
2014/53/EU	RED Directive

Low Voltage Requisition in accordance with IEC-61010-1.

All MAINS circuits are to be considered in overvoltage CATEGORY II.

Applications at altitudes below 2000 m must comply with:

- All circuits connected to the actuator relays contacts (OUTPUT SIGNALS) must refer to the same power supply system (both SELV or NON-SELV).
- All remote commands (INPUT SIGNALS) must refer to the same power supply system.

Applications in altitude between 2000 and 4000 m must have INPUT and OUTPUT SIGNALS referred to the same power supply system (both SELV or NON-SELV).

1.4 Terms and Conditions

Biffi Italia s.r.l. guarantees every product to be free from defects and to conform to industry standards. The warranty period is one year from the date of installation by the first user or eighteen (18) months from the date of shipment to the first user, whichever occurs first. No warranty is given for products or components manufactured by third-party companies or for goods which have been subject to misuse, improper installation, corrosion or which have been modified or repaired by unauthorized personnel. Repair work due to improper use will be charged at standard rates.

Before carrying out any operation with the actuator or any maintenance intervention, all the instructions, procedures and warnings described in this Installation, Operation and Maintenance (IOM) Manual must be read and understood.

Figure 1. F01-3000 Product Overview

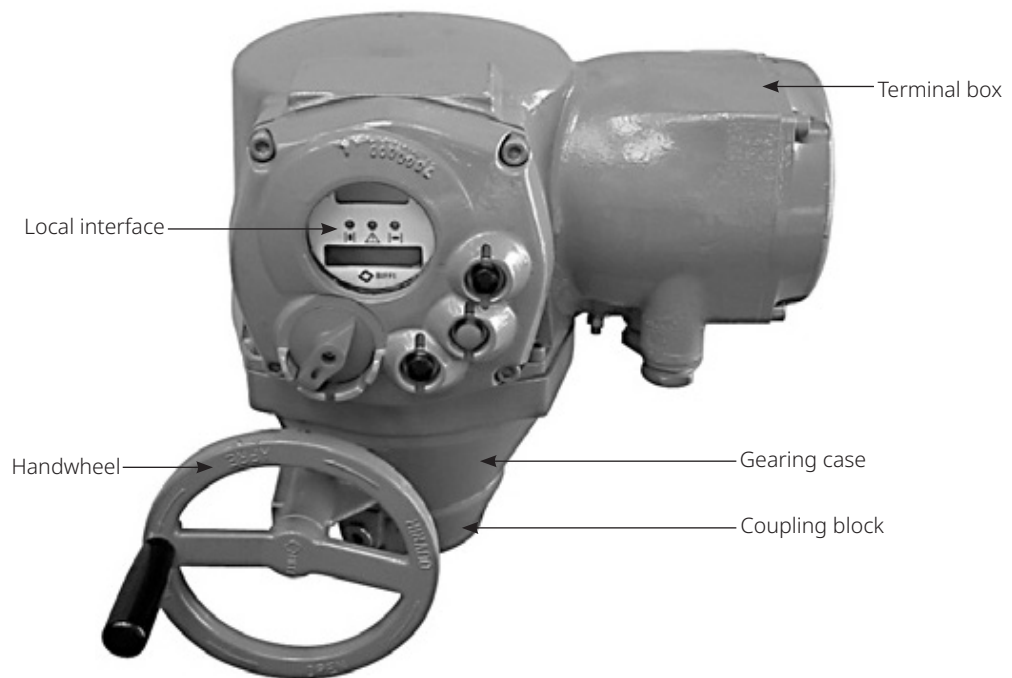

Section 2: Storage and Pre-Installation

2.1 Tests to be Carried Out When the Actuator is Received

If the actuator is received already mounted on the valve, all operations should have already been performed during valve/actuator assembly.

- Check that the display is active, only if lithium battery is present.
- Turn the handwheel until the valve is in a completely open position.
- Check that the display reads 100% indicating that the valve is completely open, only if lithium battery is present.
- Rotate the handwheel clockwise and bring the valve to a completely closed position.
- Check that the display reads 0% indicating that the valve is completely closed.

If the test result is satisfactory, the actuator has already been adjusted and you can proceed with the electrical connection.

If the actuator is delivered separately from the valve or the above procedure shows that the position is incorrect, all operations described in this manual must be carried out, only if lithium battery is present.

- Check that no damage has occurred during transport, especially to the pushbuttons, the display area glass and the selector.
- Check the information on the nameplate: serial number and performance data (nominal torque, operation speed, protection class, motor supply voltage, etc.) and verify the corresponding data on the display, see Section 10.

Make sure all accessories have been received with the shipment as described in the delivery documentation.

2.2 Storage Procedure

NOTICE

Not following the procedures according to this document will invalidate the product warranty.

2.2.1 General

The actuator leaves the factory in perfect condition, as guaranteed by an individual test certificate. In order to maintain these characteristics until the actuator is installed on site, proper procedures must be taken for preservation during the storage period.

F01-3000 actuators are weatherproof to IP66/68; this condition can only be maintained if the unit is correctly installed on-site and if the actuator was correctly stored. The standard plastic plugs used to close the cable entries are not weatherproof; their only function is to prevent the entry of foreign objects during transport.

Ambient temperature for storage:

- For standard version: from -20 to +85 °C / from -4 to +185 °F
- For special version: from -40 to +85 °C / from -40 to +185 °F

2.2.2 Short-term Storage (One Year or Shorter)

2.2.2.1 Indoor Storage

Make sure that the actuators are kept in a dry place, laid on a wooden pallet and protected from dust.

2.2.2.2 Outdoor Storage

- Make sure that the actuators are protected from the direct action of weather agents (protection by a canvas tarp or similar cover).
- Place the actuators on a wooden pallet or some other raised platform, so that they are not in direct contact with the ground.
- If the actuators are supplied with standard plastic plugs, remove them from the conduit entries and replace them with weatherproof plugs.

2.2.3 Long-term Storage (More Than One Year)

2.2.3.1 Indoor Storage

In addition to the instructions at Section 2.2.2.1.

- If the actuators are supplied with standard plastic plugs, replace them with weatherproof plugs.
- If the actuator is provided with a lithium battery, remove it and store it in a clean and dry location. See Section 11.3, Lithium Battery Change to prevent reduction of lithium battery life.

2.2.3.2 Outdoor Storage

In addition to the instructions at Section 2.2.2.2.

- Check the general conditions of the actuator, paying particular attention to the terminal board, fuse enclosure and local display glass.
- If the actuator is provided with a lithium battery, remove it and store it in a clean and dry location. See Section 11.3, Lithium Battery Change to prevent reduction of lithium battery life.

2.3 Checks to be Performed Before Installation

- Make sure the valve to be motorised is the appropriate one for coupling to the actuator.
- The electrical supply cables must be suitable for the power rating (see the test certificate that comes with the actuator).
- Gather the right tools for the assembly and for setting the actuator controls.

If a long storage period has occurred, before reinstalling the actuator, please:

- Check the status of the O-ring seals.
- Check the installation of the plugs or conduit glands on the conduit entries.
- Check whether the enclosure covers or the actuator body are cracked or broken.
- Check the oil level in the actuator and top up if necessary.
- Put the batteries back into place (see Section 11.3, Maintenance - Lithium Battery Change).

In case of negative check, refer to Section 12, Troubleshooting.

Section 3: Installation

3.1 Working Condition

The standard actuators are suitable for the following environment temperatures:

- -20 to +85 °C / -4 to +185 °F

Special versions are available for extreme environment temperatures:

- -40 to +85 °C / -40 to +185 °F - Low temperature version
- -50 to +65 °C / -58 to +149 °F* - Extreme Low temperature version

Altitude up to 4000 m maximum.

NOTICE

The above conditions apply only to Ex d or Ex d e versions. For other ambient temperature range, refer to the applicable addendum.

NOTICE

Check the "temperature environment range" embossed on the nameplate, for the correct utilization with respect to the environment temperature.

NOTICE

For hazardous area, minimum temperature can be different according to model or certification requested.

NOTICE

The minimum working temperature mentioned for extra-low temperature version is intended with heater permanently supplied.

⚠ WARNING

For actuator model with heater supplied by reserved voltage (R1 and R2 terminals), when ambient temperature < -40 °C is mandatory, switch on heater supply at least 1 hour before power on actuator.

⚠ WARNING

For actuators model with heater supplied by actuator main voltage (L1 and L2 or L1 and L3 terminals), is forbidden, switch on the actuator supply when ambient temperature is < -40 °C, the user needs to verify ambient temperature before switch on actuator power supply.

3.1.1 Heater Options

Actuators are suitable for ambient temperature range as per Product Data Sheet. Heater options are available for specific application.

Table 2. Heaters

	Model			Ambient Temperature Range		Control Type
	Heater Type	Heater Power Supply	Heater Power	Low Temperature up to -40 °C / -40 °F	Extreme Low Temperature -41 to -60 °C / -41.8 to -76 °F	Power ON and OFF managed by thermostat assembled on the kit; Power ON: < 0 °C ; Power OFF: > 10 °C
						Heater Externally powered
1	PTC - A	24 V DC	maximum 15 W	Optional	N/A	✓
2	PTC -B	110 to 240 1 ph	maximum 15 W	Optional	N/A	✓
3	PTC - C*	24 V DC	maximum 65 W	N/A	Mandatory	✓
4	PTC - D*	110 to 240 1 ph	maximum 45 W	N/A	Mandatory	✓

NOTE:

* Default in case of Extreme Low Temperature Range.

NOTICE

PTC (C) Actuator Power Supply ON (Start up or after Power shortage)

In the event of an ambient temperature below -40 °C (°F), the Actuator Main Power supply must be kept ON or preceded by a preheating time. Actuator Main Power supply can be switch ON after a warming up period. The minimum heating time must not be less than 60 minutes in case of ambient temperatures down to -60 °C.

NOTICE

Installation in an environment where the ambient temperature range falls outside the rated temperature will invalidate the warranty. Refer to the nameplate to verify the rated ambient temperature.

3.2 Coupling Block: Disassembly from the Actuator

The bushing is delivered already assembled to the drive sleeve, even when it is unmachined. In order to perform the necessary machining, remove the bushing from its housing. Remove the fixing screws from the coupling block.

Actuator view from the coupling side, with the bushing separated from the gearbox. Do not lose the seal ring between the coupling block and the gear reduction unit.

Figure 2. Access to the Drive Sleeve

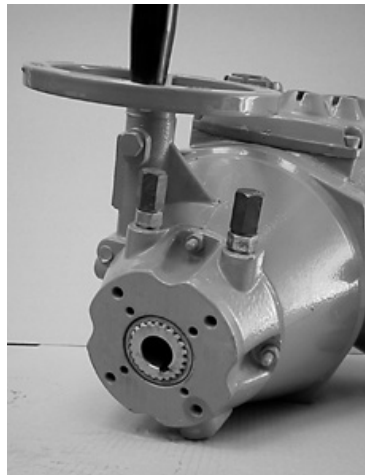

Figure 3. Drive Sleeve Retraction

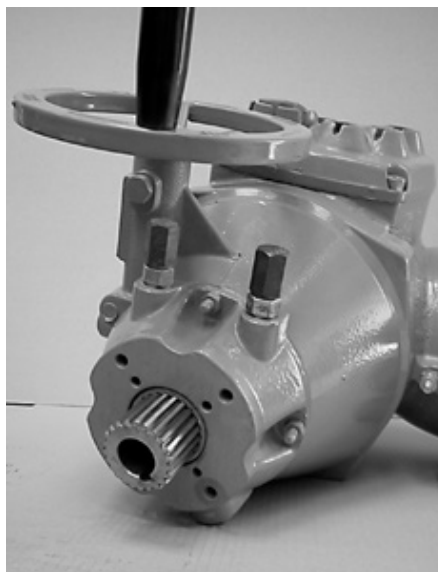

Figure 4. Drive Sleeve Removed

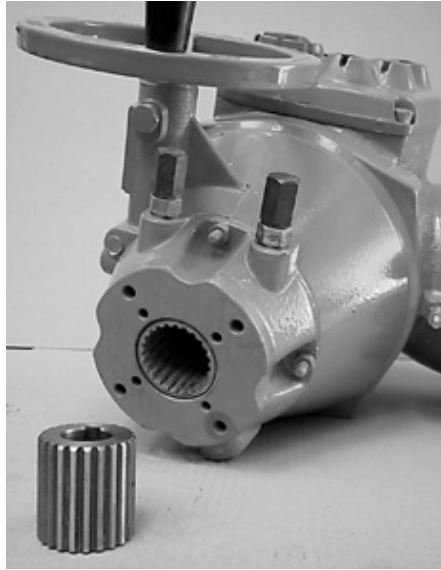
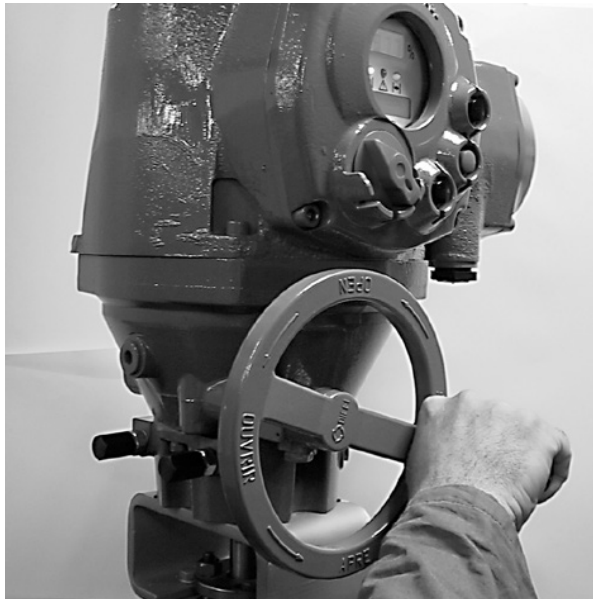

Figure 5. Handwheel Operation



3.3 Manual Operation

To manually operate the actuator, it is sufficient to turn the handwheel in the desired direction.

⚠ WARNING

Do not manually operate the actuator with devices other than the handwheel. Using cheater bars, wheel wrenches, pipe wrenches or other such devices on the actuator handwheel may cause serious personal injury and/or damage to the actuator or valve.

3.4 Mounting the Actuator onto the Valve

Lubricate the valve stem. Thoroughly clean the coupling surfaces of the valve and actuator flanges, degreasing them carefully since torque is transmitted by friction.

Lift the actuator with slings suitable for its weight. Check the dimensions of the valve mounting details, paying particular attention to the protrusions of the valve stem in order to avoid any axial thrusts to the internal parts of the actuator or the valve when the screws are tightened.

Place the actuator vertically on the valve stem. Carry out the coupling operations (if necessary with the help of manual operation); make sure no mating parts are forced.

Figure 6. Actuator Lifting

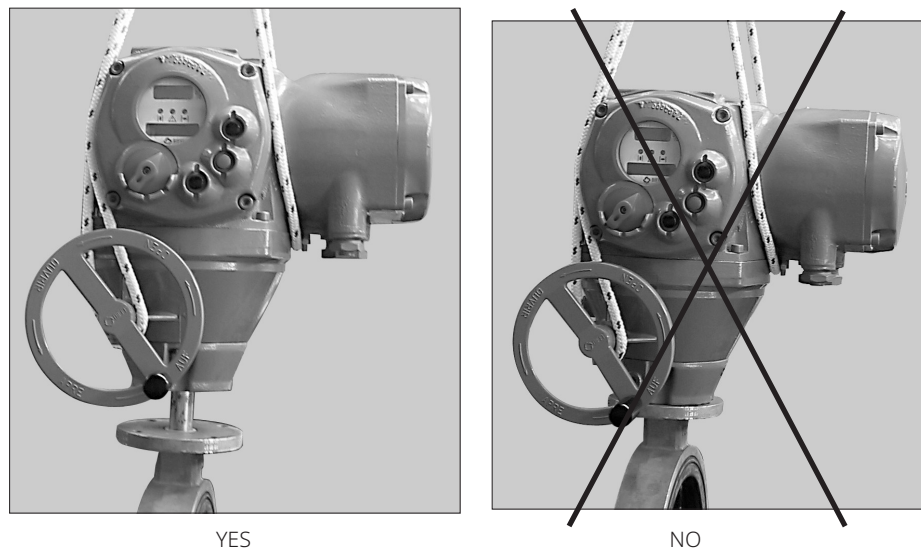

NOTICE

In case the actuator is supplied without stud bolts and nuts the following materials must be used as a minimum:

- ISO class 8.8 for studs bolts and nuts or
- ASTM A 320 Grade L7 (or L7M) for studs bolts
- ASTM A 194 Grade 4 for nuts

⚠ WARNING

Never lift the valve/actuator assembly without securing slings to both the valve and the actuator.

Table 3. Actuator Weight

Size (DN)	Maximum Weight (kg)
F01-3000/150	26
F01-3000/300	26
F01-3000/600	28

Table 4. Mounting Bolt Tightening Torque

Model	Tightening Torque (Nm)
F01-3000/150	40
F01-3000/300	40
F01-3000/600	80

3.5 Electrical Connections

Before powering to the actuator, check that the supply voltage details on the nameplate are correct for the plant. Access to terminals for electrical connections and commissioning is through the terminal cover since all settings are non-intrusive. The removal of any other covers without Biffi's approval will invalidate the warranty.

Biffi will not accept any responsibility for any damage or deterioration that may be caused.

NOTICE

All the accessories (in particular cable glands) must be certified according to 2014/34/EU Directive.

3.5.1 Identification of Entries

Electric actuators series F01-3000 are equipped with 4 entries (3 are standard, the fourth is supplied when requested).

With reference to Figure 7, the thread form/size for entry is as follows:

Figure 7. Wiring Terminals

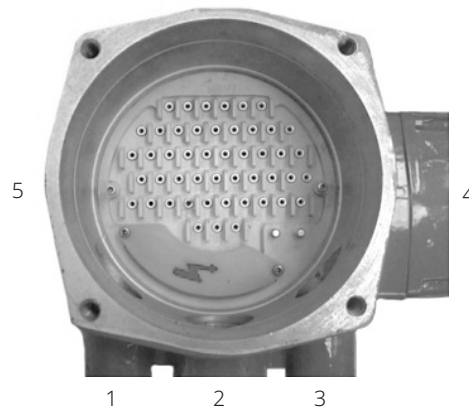

Table 5. Cable Entry List

Entry	NPT Size	Tightening Torque (Nm)
1	1 in.	M32x1.5
2	1-1/2 in.	M40x1.5
3	1 in.	M32x1.5
4*	3/4 in.	M25x1.5
5*	3/4 in.	M25x1.5

NOTE:
* optional

NOTICE

When alternative entries according to ISO 965 are used, indication of the dimensions is imprinted on the adapter bush or directly on the housing when ISO 965 entries are created by machining the housing.

⚠ WARNING

Unused entries may remain unmachined or must be plugged with a certified plug suitable for the subject environment.

3.5.2 Plants Requirements

Protection devices (overcurrent breakers, magneto-thermal switches or fuses) should be provided on the plant at Customer care, to protect the mains line in case of motor overcurrent or loss of insulation between phases and earth.

For the proper sizing of protection devices, refer to certificate attached to the actuator (Is current).

Protection devices must be easily reached and identifiable by the operator.

3.6 Removing the Electrical Enclosures' Covers

Using a 8 mm Allen key, loosen the four screws and remove the cover.

3.6.1 Terminal Board Enclosure

WARNING

Be careful not to damage the joint surfaces of the terminal cover or seal during removal.

CAUTION

Using a fastener other than the approved type may result in damage to the actuator or valve. Refer to Table 7.

NOTICE

If the screws of the cover must be replaced, a SS AISI 316 must be used with minimum yield strength of 450 N/mm² / 65266 psi.

CAUTION

Failure to use proper torque values can result in damage to the actuator and/or valve.

3.7 Cable Entries

The sealing of cables and conduit entries should be carried out in accordance with National Standards or the Regulatory Authorities that have certified the actuators. This is particularly true for units that are certified for use in hazardous areas where the method of sealing must be to an approved standard and cable glands, reducers, plugs and adapters must be approved and separately certified.

Standard cable entries (housing):

- 1 in. NPT, Quantity 2
- 1-1/2 in. NPT, Quantity 1
- Optional: 3/4 in. NPT, up to Quantity 2

On request, certified conduit entry adapters may be added:

- Metric, Pg, Rc, ASA, etc.

Remove the conduit entry plugs.

NOTICE

All accessories (including cable glands) must comply with approved specifications for the site requirements and be certified according to the standard directive.

To guarantee weatherproof and explosion-proof fit, screw the cable glands tightly (at least 5 turns) and block them with a thread sealant. The use of a thread sealant is necessary in case of explosion-proof application.

If some parts of the cable glands have been removed while working on the cable entries, put them back into place now to avoid losing the dismantled parts.

Unused entries:

- For explosion-proof construction: unused entries must be plugged with metal explosion-proof plugs and blocked with a thread sealant.
- For weatherproof construction: replace the plastic standard protection plugs supplied with the actuator with metal plugs.

Figure 8. Cable Entries



3.8 Terminal Board

WARNING

Installation, configuration, commissioning, maintenance and repairs must be performed by approved and qualified personnel only.

WARNING

The actuator is non-intrusive. The control compartment is sealed in dry and clean conditions and contains no site-serviceable components. Do not open the control compartment unless absolutely necessary. Unauthorized access will invalidate the warranty.

NOTICE

Be careful not to damage the joint surfaces of the terminal cover or seal during removal.

NOTICE

When removing the cover assembly or terminal block cover on existing installations, follow all safety and applicable site-specific rules.

NOTICE

The removal of any other covers without Biffi's approval will invalidate the warranty. Biffi will not accept any responsibility for any damage or deterioration that may occur as a result of cover removal.

Terminate the ground connections to the ground stud marked \perp , one internal and one external ground studs are provided. Before performing service or maintenance operations (unless otherwise indicated), ensure that power is turned off to the unit to avoid injury or damage to equipment. Check the wiring diagram (always enclosed with the actuator) and the layout displayed on the back of the terminal's enclosure cover, to ensure a correct electrical connection.

All terminations should be made by insulated ring or spade connectors using the appropriate crimping tool. This operation will ensure easy and correct electrical connection.

Connect the motor supply cable previously sized in accordance with:

- The absorbed current correspondent to the actuator nominal torque with the torque limiting device set at 100 percent (see the test certificate attached to the actuator).
- The applicable plant and safety norms.

Assemble the power terminals protective barrier, located in the terminal board compartment, using the enclosed screws. The control circuit (controls and signals) must be connected by means of a multicore cable to the corresponding numbered terminals according to the wiring diagram.

The internal cables of the actuator are also numbered according to the wiring diagram. Actuators are always delivered with the motors wound and connected in accordance to customer requests. Voltage and frequency values are stated on the motor nameplate.

Figure 9. Ground Stud

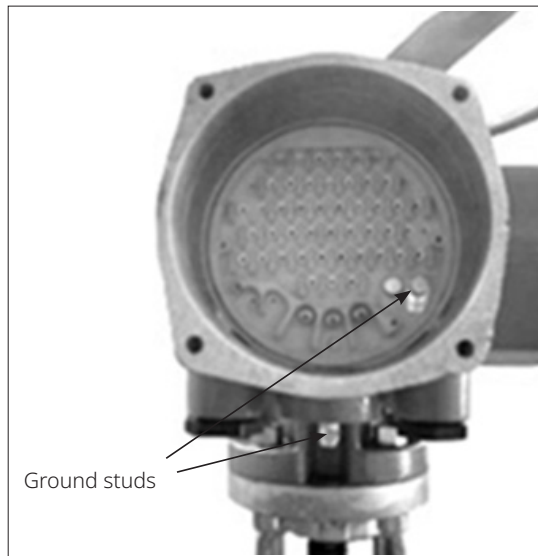

Figure 10. Wiring Terminals



Figure 11. Terminal Indication



Connections for Ex e terminals enclosure

The wires must be terminated in accordance with the following method (see connection in Table 6):

Table 6. Connection Table

	Power Cables	Control Cables
Type of terminal	Insulated ring tongue	
Eye dimensions (mm)	5.50	3.20
Recommended tightening torques (Nm)	2.0 to 2.8	1.0 to 1.5
Wires section (mm ²)	4	2.5

Table 7. Bolting Table

Model	Motor Cover	Terminal Enclosure/ Local Interface Covers	Material
F01	M10x35	M10x30	AISI 316/ASME B16.11 A182-F316 (yield strength ≥ 450 N/mm ²)

Figure 12. Ring Terminal

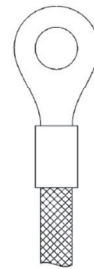

NOTICE

When alternative entries are used, indication of the dimensions is imprinted directly on the housing close to the entry.

NOTICE

To prevent any water infiltration through the line cable conduits, be sure the cable glands used have the minimum degree of protection IP66.

⚠ WARNING

Unused entries may remain unmachined or must be plugged with a certified plug suitable for the area.

3.9 Instructions for the Explosion-Proof Enclosures

NOTICE

Electric actuator F01-3000 shall be installed and maintained according to the applicable rules regarding the electrical installations in hazardous area (other than mines) classified as zone 1 (gas); example: EN 60079-10 (hazardous area classification), EN 60079-14 (electrical installation), EN 60079-17 (maintenance) and/or other national standards.

During the dismantling and subsequent reassembling of the explosion-proof enclosures (covers, cable glands, joints), be careful to bring these enclosures back to their original condition to maintain their integrity. In particular, be sure the joint surfaces of all enclosures are spread with a film of recommended grease (see Section 4, Lubrication) to prevent damages to explosion-proof joints.

So please:

- Do not damage the explosion-proof mating surfaces on the housing and on the electrical enclosures covers.
- Reinstall all the screws that go with the dismantled parts and block them with a thread sealant after spreading them with a film of copper- or molybdenum-based grease. This will keep screws from sticking and make maintenance operations easier.
- Check that the bolts and screws are the same dimension and quality as the original ones (see bolting table) or of a better quality.

DANGER

Do not electrically operate the actuator when the electrical covers are removed. Do not open the actuator covers when an explosive atmosphere may be present. Ignoring the above precautions may result in personal injury or death.

- Replace the weatherproof seals that may have been removed (O-ring for the covers, O-ring for the explosion-proof joint of the motor).

When the Ex d e version is supplied, according to the protection degree shown on the nameplate, waterproof cable glands with a minimum IP68 protection degree, can be used.

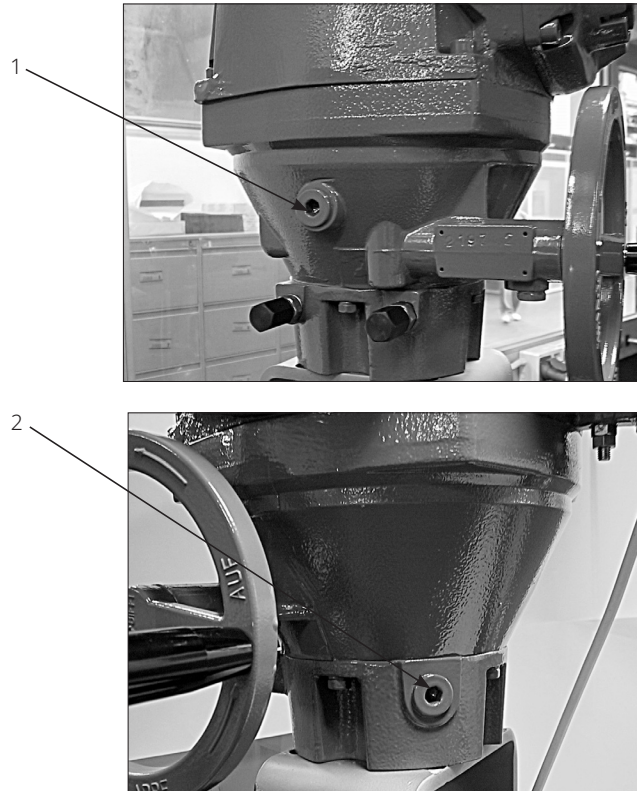
Figure 13. Lubrication Port

3.10 Installation in Environment with Explosive Dusts

NOTICE

Electric actuator F01-3000 shall be installed and maintained according to the applicable rules regarding the electrical installations in hazardous area (other than mines) classified as zone 21 (dust); example: EN 61241-14 (dust) and/or other national standards.

Please make sure that:

- The joint surfaces are greased with silicon oil or equivalent before assembly.
- The cable glands have minimum protection degree IP6X (EN 60529).
- Periodically verify the quantity of dust deposited on the enclosure and clean it if more than 5 mm.

Section 4: Lubrication

4.1 Lubrication Inspection

The actuator is lubricated for the duration of its service life; under normal working conditions, it is not necessary to replace or refill the oil. However, it is recommended to check the oil level every 3 to 5 years using holes 1 or 2 (see Figure 13) depending on what orientation the actuator was mounted.

The actuator is fitted with oil plugs (parts 1 and 2), such that any assembly on the valve has at least one oil plug on the upper part of the housing and one on the lower part.

A spherical head lubricator (part 3) is fitted on the coupling block for the proper greasing of the inside thrust or sliding bearings.

The actuator is supplied with oil and greased where necessary.

Should maintenance become necessary, the following OILS are recommended:

Ambient temperature from -20 to +85 °C

- SHELL - OMALA® S4 WE 320 or equivalent

Ambient temperature from -40 to +85 °C

- SHELL - TELLUS® S4 ME 46 or equivalent

Ambient temperature from -60 to +65 °C

- Synduro® SHB 46 or equivalent

Should maintenance become necessary, the following GREASES are recommended:

Ambient temperature from -20 to +85 °C

- AGIP GREASE MU EP 2 or equivalent

Ambient temperature from -40 to +85 °C

- Molykote® 33M or equivalent

Ambient temperature from -60 to +65 °C

- Molykote 33M or equivalent

Table 8. Oil Fill Volume

Actuator Size	Oil Quantity (l)
F01-3000/150	0.7
F01-3000/300	0.7
F01-3000/600	0.8

Section 5: Operating the F01-3000

5.1 Operation by Handwheel

To manually operate the actuator, it is sufficient to turn the handwheel in the desired direction. The manual operation is always possible without any clutching mechanism.

Figure 14. Handwheel Operation

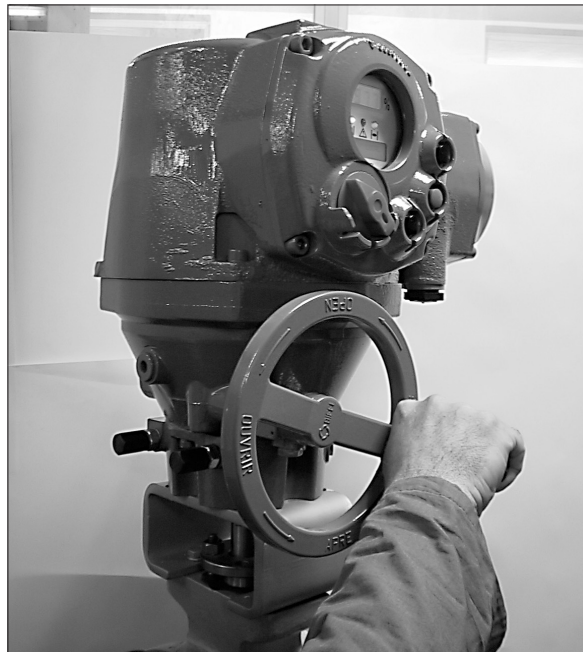

⚠ WARNING

Do not manually operate the actuator with devices other than the handwheel. Using cheater bars, wheel wrenches, pipe wrenches or other such devices on the actuator handwheel may cause serious personal injury and/or damage to the actuator or valve.

5.2 Setting of Mechanical Stops

Necessary equipment: a 3 mm hexagonal key.

According to the type of valve to be operated, the actuator can be stopped by means of torque or position limit switches, as detailed in the following list:

Valve type: metal seated butterfly valve

Closing: torque

Closing: position

Valve type: ball valve, butterfly valve, plug valve

Opening: position

Opening: position

Before any setting operation, it is necessary to unscrew the adjustable mechanical stops.

Figure 15. Mechanical Stops

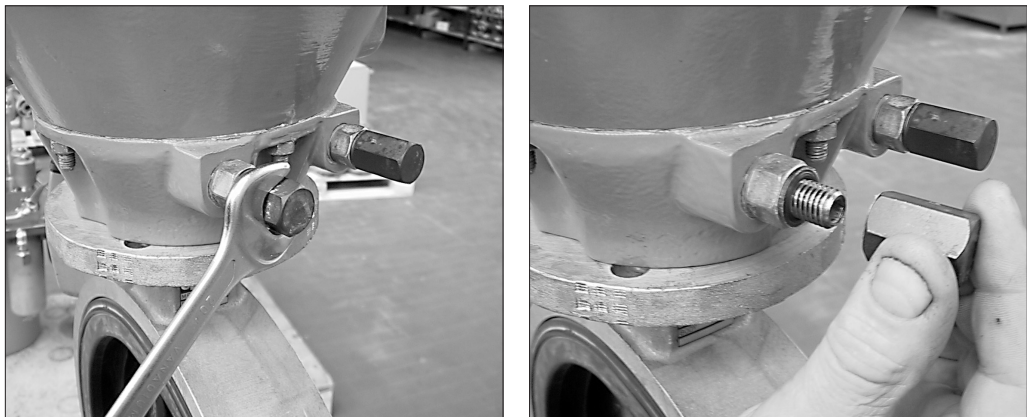

Hold the lock nut and remove the mechanical stop protection by unscrewing it. Remove the seal washer.

Figure 16. Stop Screw Adjustment

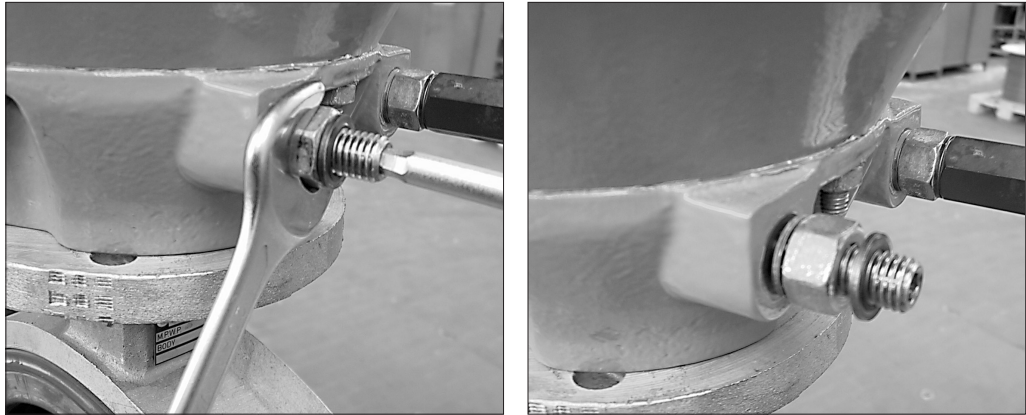

Hold the mechanical stop by means of a suitable Allen key and in the same time loosen the lock nut by one turn.

Screw the closing or opening mechanical stop until it reaches the end stroke. From here unscrew it by half a turn and lock it with the lock nut. Check the protrusion of the mechanical stop, for a stroke of $90^\circ \pm 5^\circ$, length "L" should be within the following values:

Table 9. Stop Screw Adjustment Range

Size	L Maximum (mm)	L Minimum (mm)
F01-3000/150	24	16
F01-3000/300	24	16
F01-3000/600	29	18

Figure 17. Stop Screw Adjustable Range

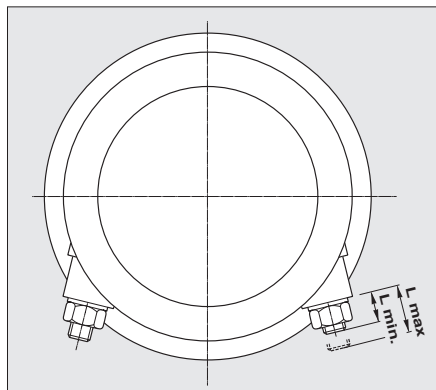

5.3 Electrical Operation

Before connecting power to the actuator, check that the voltage is correct and according to the indications on the nameplate. Wrong power supply could cause a permanent damage to the electrical components. Check of phase rotation is not necessary since the unit is provided with automatic phase rotation correction. Place the 3-position selector in OFF and then switch on the power. Do not operate the actuator without first checking that the configuration is according to the required application. Using the "VIEW and SET-UP" features can do this, see Section 6.4.

Power supply limits

Voltage: +/- 10% (continuous) +10% -15% (intermittent)

Nominal duty: -5%/5% according to IEC 60034-1

Total Harmonic Distortion (THD): maximum 5% according to IEC 60034-1

Form and symmetry on voltages and currents: according to IEC 60034-1 (Section 7.2.1.1)

CAUTION

Working outside the above limitations could damage the actuator. Be careful if an inverter or generator is used as a power supply.

5.4 Local Control

After configuring the actuator, if no alarm is present, place the 3-position selector in LOCAL and control the actuator by OPEN, CLOSE and STOP pushbuttons.

If "push-to-run" was selected the actuator can be driven to the desired position by pressing and holding the OPEN/YES or CLOSE pushbutton. As the pushbutton is released, the motor is de-energized.

If "latched" was selected, as the OPEN or CLOSE pushbutton is pressed the motor is energized and it runs on after the control is released. To stop the motor, press the STOP pushbutton. To reverse the direction, press the STOP pushbutton and then press the pushbutton relevant to the opposite direction.

In "latched with instant reverse" mode, the local controls work as in the "latched" mode, but to reverse the motor direction you only need to press the pushbutton relevant to the opposite direction.

Depending on the position of the local selector, the OPEN/YES and CLOSE/NO push-buttons work as follows:

- OPEN/CLOSE commands if the selector is in the LOCAL position.
- YES/NO to answer prompts in the menu, if the selector is in the OFF or REMOTE positions.

Figure 18. Local User Interface

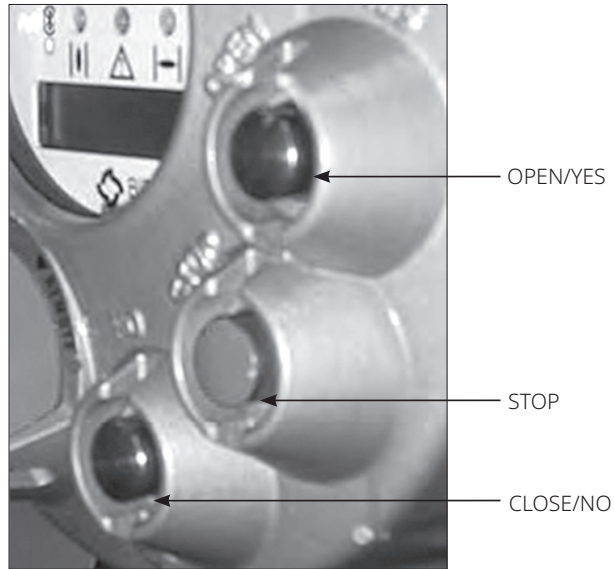

5.5 Local Indication

By default, the upper display indicates the valve position as a percentage of opening (open = 100%). The lower display in the upper part shows icons that indicate the actuator status or the Menu, where the user is operating.

The lower display in the lower part is organized in two lines. The upper line indicates the actuator status and the 3-position selector status. The lower line indicates the actuator operation or the position request % value, according to the configuration.

Two Light-Emitting Diodes (LEDs) indicate the actuator position and operating direction (OPEN or CLOSE), while a third and fourth LED indicate alarms and Bluetooth® connectivity, respectively.

Figure 19. Local User Interface



Figure 20. Pushbuttons

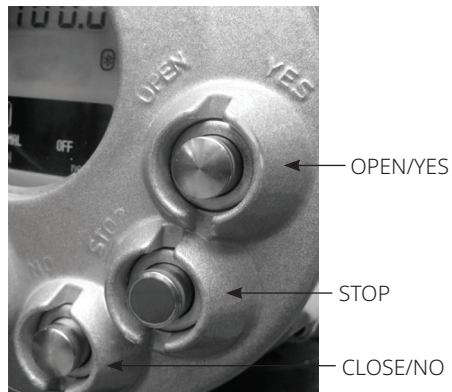
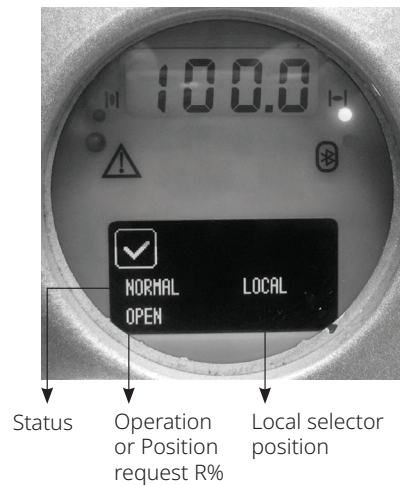

Figure 21. Display



5.6 Lock of the 3-Position Selector

The 3-position selector can be locked in any of its three positions by means of a padlock.

Figure 22. Lockable Selector

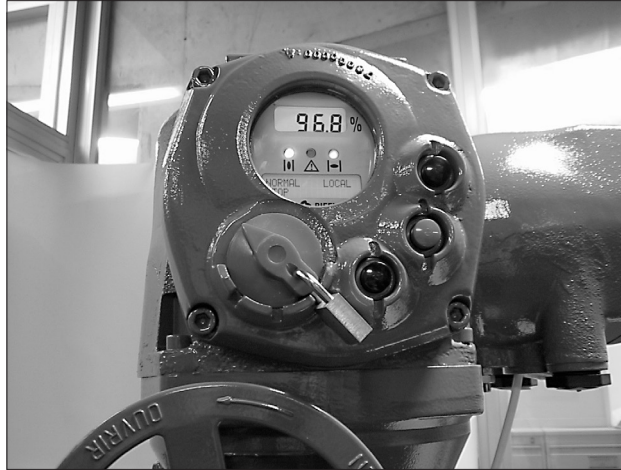

5.7 Remote Control

Place the 3-position selector in REMOTE to transfer the actuator control to a remote device. Local OPEN or CLOSE operation will be inhibited. Only local STOP control remains active.

Using the "VIEW and SET-UP" features may configure different control modes. The remote controls are opto-coupled.

A non-regulated 24 V DC voltage (variable from 23 to 27 V DC, maximum 4 W) is available on the actuator terminal board to supply the remote controls or external devices.

5.7.1 Remote Commands

Using the "VIEW and SET-UP" features may configure different control modes.

4 WIRES (see the remote connections diagram) In "4 wires latched" (OPEN, CLOSE, STOP, COMMON) mode, with the OPEN or CLOSE signal switched to ON, the motor is energized and it runs on after the signal returns to OFF. To stop the motor, press STOP. To reverse the direction, press STOP and then press the button relevant to the opposite direction.

3 WIRES (see the remote connections diagram) With option “3 wires” (OPEN, CLOSE, COMMON), the actuator can be driven in either “push-to-run” or “latched with instant reverse” mode.

In “push-to-run” mode, the actuator can be driven to the desired position by switching the OPEN or CLOSE signal to ON. As the signal returns to OFF, the motor is de-energized.

In “latched with instant reverse” mode, when the OPEN or CLOSE signal switches to ON, the motor is energized and it runs on after the signal returns to OFF. If the signal relevant to the opposite direction goes ON, the actuator reverses its direction and maintains the new direction also if the signal returns to OFF.

2 WIRES (see the remote connections diagram) With the “2 wires” option 2 different activities may be selected:

In “2 wires, signal ON to open”, the actuator opens if the signal switches to ON and closes if the signal goes to OFF. In “2 wires, signal ON to close”, the actuator closes if the signal switches to ON and opens if the signal switches to OFF.

The circuits associated to the inputs can be supplied by the internally generated 24 V DC or by an external 20 to 125 V DC or 20 to 120 V AC (50/60 Hz).

The signal levels are the following:

- Minimum ON signal > 20 V DC or 20 V AC (50/60 Hz)
- Maximum ON signal < 125 V DC or 120 V AC (50/60 Hz)
- Maximum OFF signal < 3 V DC or V AC
- Minimum signal duration > 500 ms
- Total current drawn from remote controls < 25 mA

Figure 23. Wiring Diagram

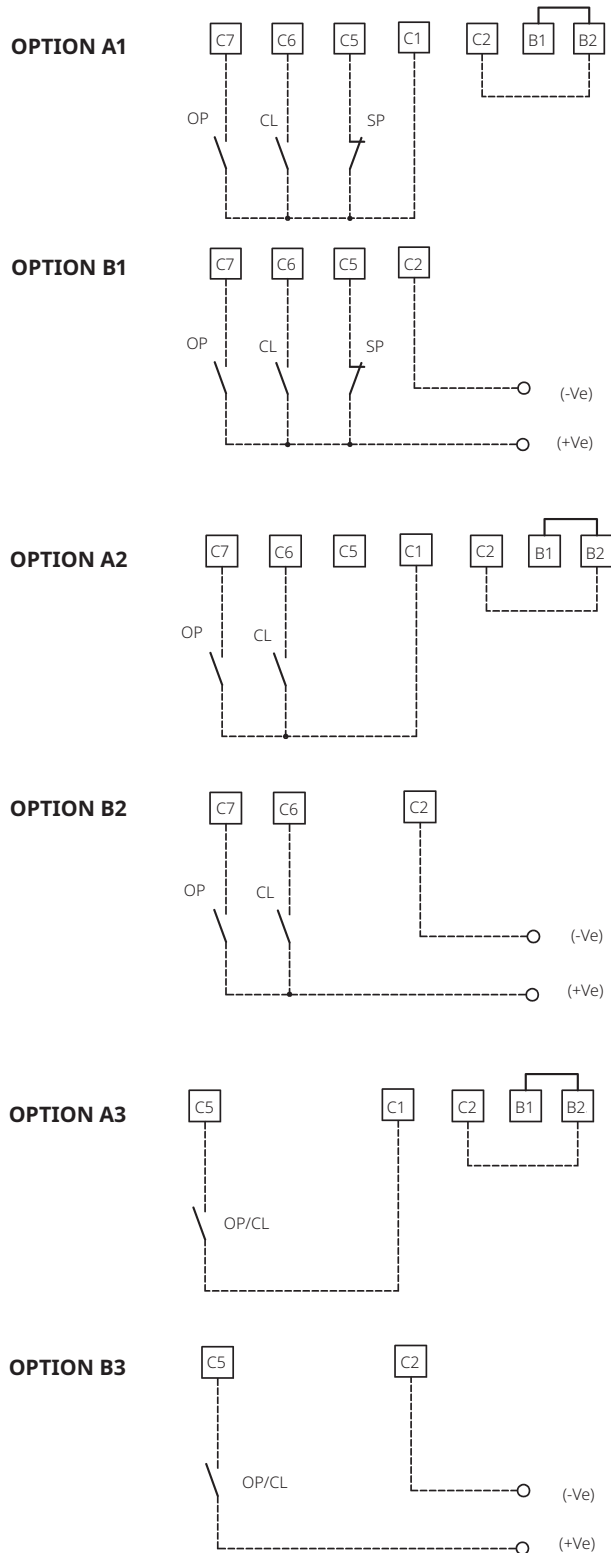

5.7.2 Output Contacts

- Monitor relay: on the terminal board, the voltage-free, change-over contacts of the monitor relay are available. The monitor relay indicates that the actuator can be remotely controlled or that there is a problem or condition which prevents remote control of the valve. The conditions that cause the relay to switch over are listed in Section 9.1.6, Output Relays.
- AS1, 2, 3, 4, 5, 6, 7 relays: the voltage-free contacts of 7 latching relays are available on the terminal board. The status (make or break) and the conditions that cause switching of a given relay can be viewed and configured by using the "VIEW and SET-UP" features. The status of the latching relays is immediately updated if the associated conditions for change occur or are cyclically updated (every second).
- AS8 relay: a further voltage-free, change-over contact is available on the terminal board. The conditions that cause the switching of the relay can be viewed and configured by using the "VIEW and SET-UP" features.
- Contact rating:
 - Maximum voltage 250 V AC / 30 V DC
 - Maximum current 5 A
 - Minimum voltage 5 V DC
 - Minimum current 10 mA

5.7.3 ESD Operation

An ESD (Emergency Shut Down) signal can be sent to the actuator to override any existing command and to drive the valve to a predetermined position. The control is not self-maintained, that is, the ESD action continues until the relevant signal is present.

The "VIEW and SET-UP" features can configure different ESD options. The ESD command is opto-coupled. The circuits associated to the input can be supplied by the internally generated 24 V DC or by an external 20 to 125 V DC or 20 to 120 V AC (50/60 Hz).

The signal levels are the following:

- Minimum ON signal > 20 V DC or 20 V AC (50/60 Hz)
- Maximum ON signal < 125 V DC or 120 V AC (50/60 Hz)

5.7.4 ESD Operation

An ESD (Emergency Shut Down) signal can be sent to the actuator to override any existing command and to drive the valve to a predetermined position. The control is not self-maintained, that is, the ESD action continues until the relevant signal is present.

The "VIEW and SET-UP" features can configure different ESD options. The ESD command is opto-coupled. The circuits associated to the input can be supplied by the internally generated 24 V DC or by an external 20 to 125 V DC or 20 to 120 V AC (50/60 Hz).

The signal levels are the following:

- Minimum ON signal > 20 V DC or 20 V AC (50/60 Hz)
- Maximum ON signal < 125 V DC or 120 V AC (50/60 Hz)
- Maximum OFF signal < 3 V DC or V AC
- Current drawn from ESD controls < 15 mA

5.7.5 Interlock Inputs

Two additional inputs are available to inhibit actuator movement in open or close direction. The controls are momentary and the inhibit action continues until the relevant signal is present. The interlock controls work when the local selector is in either LOCAL or REMOTE positions. The ESD control overrides the interlock controls. The "VIEW and SET-UP" features can configure the polarity of INTERLOCK signal as described in Section 9.1.10.

The interlock inputs are opto-coupled and can be supplied by the internally generated 24 V DC or by an external 20 to 125 V DC or 20 to 120 V AC (50/60 Hz).

The signal levels are the following:

- Minimum ON signal > 20 V DC or 20 V AC (50/60 Hz).
- Maximum ON signal < 125 V DC or 120 V AC (50/60 Hz).
- Maximum OFF signal < 3 V.
- Total current drawn from remote controls < 25 mA.

Figure 24. Wiring Diagram

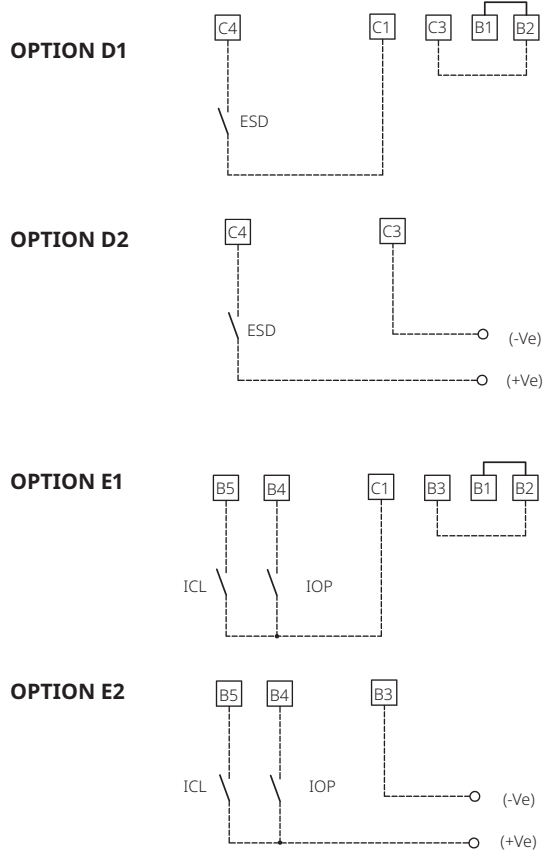

5.8 Operating the F01-3000 for the First Time

Before attempting to operate the F01-3000 for the first time, check that the actuator is correctly mounted on the valve. Place the 3-position selector in OFF and switch the power on. The alphanumeric display will show "F01-3000" for a few seconds.

If an alarm is active (i.e., the Alarm icon is shown on the display), take the necessary action to resolve the alarm before proceeding (see Section 12.10).

If a warning is active (i.e., the Warning icon is shown on the display), a warning condition is present. One can proceed since the F01-3000 will continue to function, but some data are not according to the configured parameters (see Section 12.10).

If the lower lines of the display show "INT OFF", then an interlock input is active. If the lower lines of the display show "ESD ON OFF", the ESD input is active.

Do not operate the actuator without first checking that the configuration is according to the required application by using the "VIEW and SET-UP" features (see Sections 6.3 and 6.4).

Set torque limits, position limits and close direction by means of the "Stroke Limits Routine" of the "Actuator Set-up" menu (see Section 9).

When the stroke limits and the configurations are correct, bring the 3-position selector to LOCAL and drive the actuator to open or closed position (see Section 5.4).

5.9 Optional Modules

CAUTION

The actuator contains parts and assemblies susceptible to damage via Electrostatic Discharge. Prior to performing work, use protection or discharge static electricity by touching grounded metal.

Additional modules can be plugged in the base card of the F01-3000 to provide the following functions:

5.9.1 Fieldbus Interface for Remote Control via Fieldbus

This card allows to connect the F01-3000 to FIELDBUS.

The following bus interface cards are available:

- PROFIBUS DPVO
- PROFIBUS DPV1 with or without redundancy
- PROFIBUS DPV2 with or without redundancy
- FOUNDATION™ Fieldbus
- LonWorks®
- Modbus® RTU

A Hardware alarm is generated if the F01-3000 was set to be equipped with bus card, but the card is damaged or missing. A BUS REPORT is also present in the list of reports if the card is present (see Section 6). See the specific manuals for instructions and the setting of the above modules.

5.9.2 Ain/Aout Card

With the above card, the F01-3000 is provided with a 4 to 20 mA analog input and a 4 to 20 mA analog output. This card should be plugged on the base card, replacing the "TERMINAL BOARD ADAPTOR" card supplied as standard. A Hardware alarm is generated if the F01-3000 was set to be equipped with an Ain/Aout card and the card is damaged or missing. An Ain/Aout REPORT is also present in the list of reports if the card is present (see Section 6).

4 to 20 mA analog output

The 4 to 20 mA output can be configured to provide a signal proportional to either "position" or "torque". The polarity option allows to reverse the relationship between the position or torque and the 4 to 20 mA output signal. See "VIEW and SET-UP" features (Section 9.1.9, OUT 4 to 20 mA).

The 4 to 20 mA output is opto-coupled. It should be powered by a 20 to 30 V DC voltage (externally or internally generated) and the maximum load, including the cable resistance, should be less than 300 ohm.

Figure 25 shows the wiring diagram.

Figure 25. Wiring Diagram

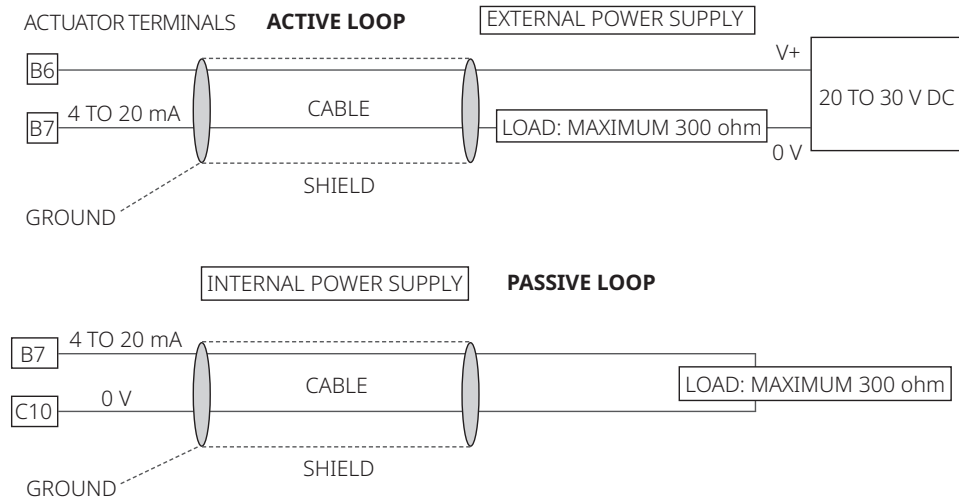

The behavior in case of loss of main voltage is different if the power supply of the 4 to 20 mA output stage is internally or externally generated:

- Internal power supply (or passive loop): In case of loss of main voltage, the output 4 to 20 mA drops to 0. The correct output will be restored when the main voltage returns.
- External power supply (or active loop): If the actuator is provided with a lithium battery (or supplied by the auxiliary 24 V DC) and if the main voltage fails, the output 4 to 20 mA maintains the last value. If the actuator is moved by handwheel, the output 4 to 20 mA will be updated. If the actuator is not provided with a lithium battery (or not supplied by the auxiliary 24 V DC) and if the main voltage fails, the output 4 to 20 mA maintains the last value. If the actuator is moved by handwheel, the output 4 to 20 mA will not be updated.

4 to 20 mA analog input

The 4 to 20 mA analog input is the position request R% signal and is used by the F01-3000 to position the valve in inching and modulating actuators. The "POSITIONER" routine processes the input signal, compares the present actuator position % with the position request R% and if the difference is greater than the dead band, the actuator is driven to reach the requested position. 4 mA corresponds to request R% = 0% = valve closed and 20 mA corresponds to request R% = 100% = valve open. The relationship between position and request signals can be reversed by the "Polarity" function. The 4 to 20 mA input is opto-coupled. The input impedance is less than 500 ohm. The loss of the 4 to 20 mA input signal is indicated as follows:

- Change-over of the monitor relay
- Alarm LED on
- List of ALARMS (see Section 12.10, Diagnostic Messages)
- Alarm log

Figure 26 shows the wiring diagram.

Figure 26. Wiring Diagram

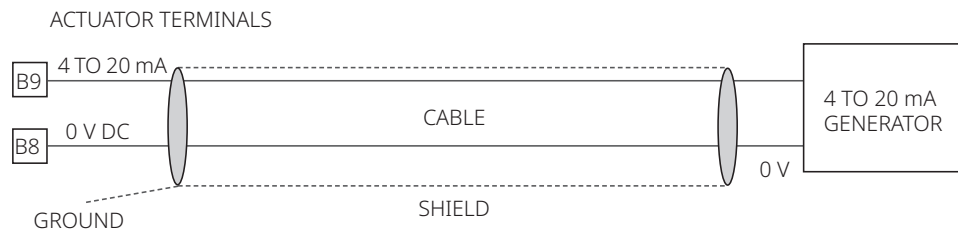

The "VIEW and SET-UP" features can configure different options which are described in Section 9.1.7, Positioner.

If the POSITIONER function is active the alpha-numeric display indicates the value of the position request in % (R%: xxx.x).

Figure 27. Wiring Diagram

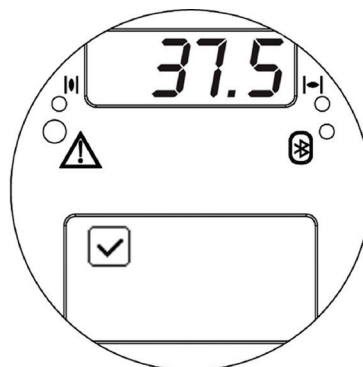

5.10 Base Card of the F01-3000

Figure 28. Bottom View of Base Card

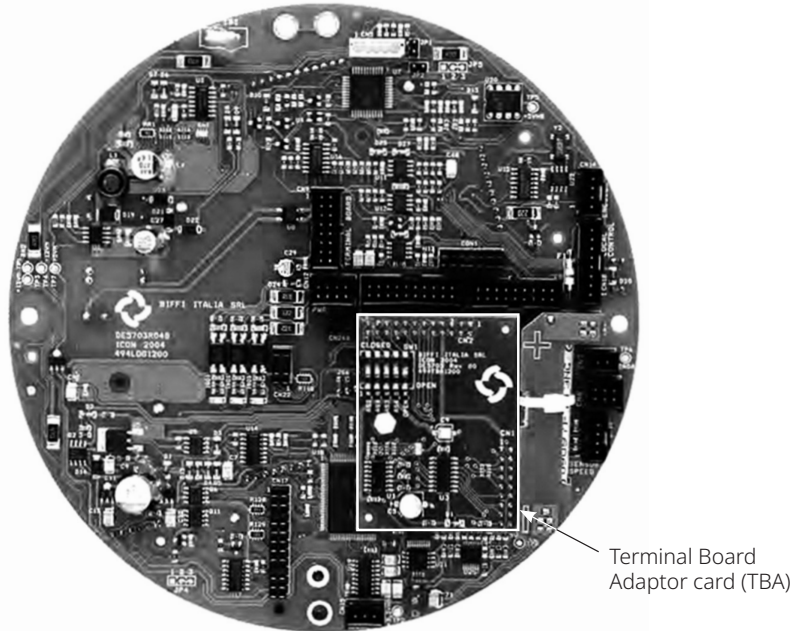

Top view of base card

Base card equipped with fieldbus interface card and Terminal Board Adaptor card.

Figure 29. Top View of Base Card

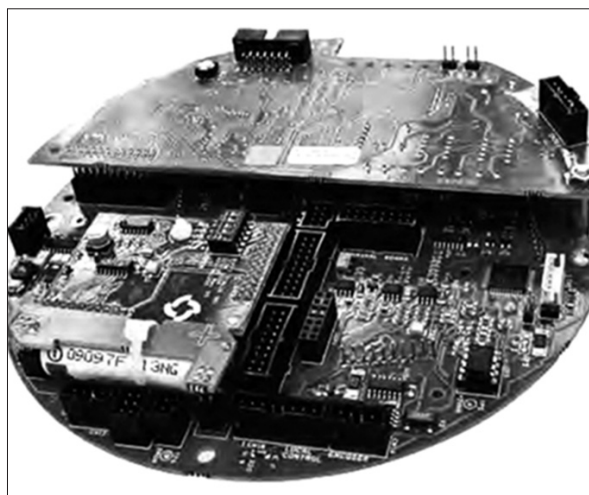

Fieldbus interface card

The type of card depends on the fieldbus present in the plant.

Figure 30. Fieldbus Interface Card

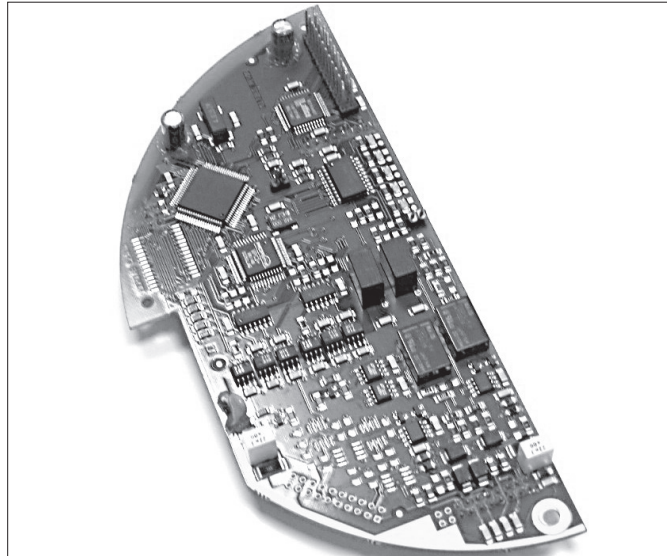
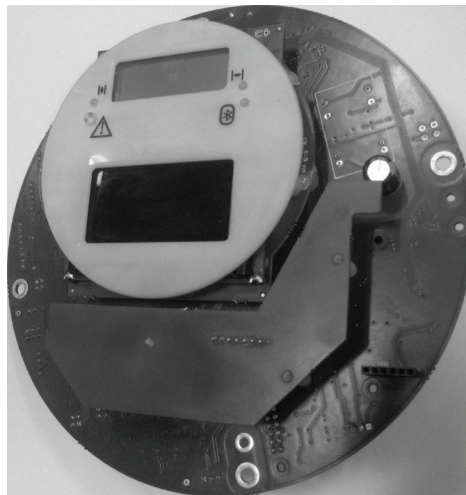

Figure 31. Logic Card



Potentiometer card

This card allows the base card to read position and torque values from the potentiometers installed on the actuator.

Figure 32. Potentiometer Card

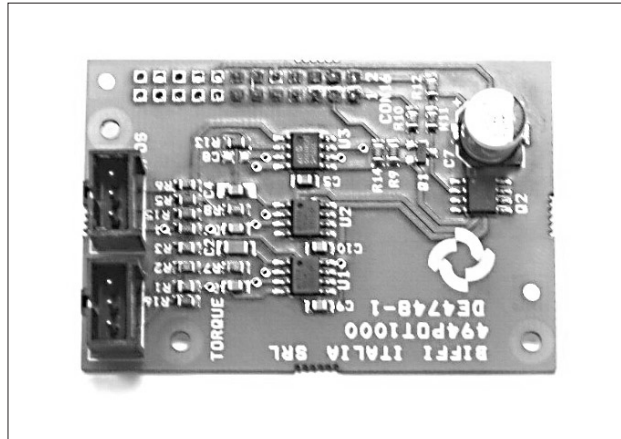

Ain/Aout card

This optional card is used in place of the Terminal Board Adaptor (TBA) card when an analog 4 to 20 mA input and output signal is requested. This card cannot be used in the actuators with terminal board series F01-3000 (see Section 5.8, Operating the F01-3000 for the First Time).

Figure 33. Ain/Aout Card

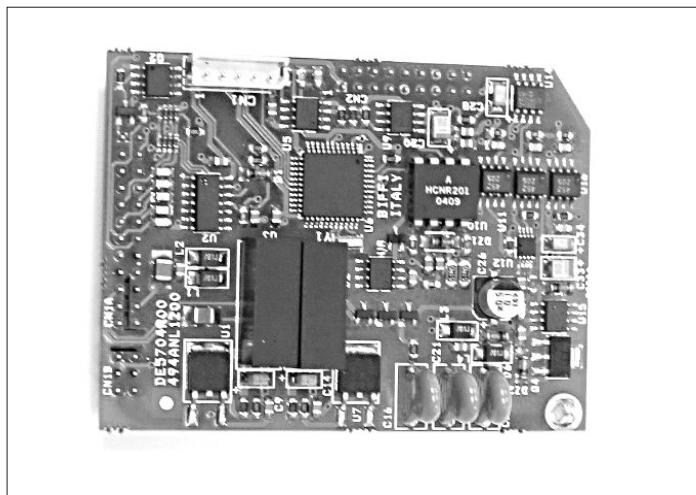

Section 6: Local Controls

6.1 Description of the Local Operator Interface

The following functions are available by the F01-3000 local operator interface:

- Actuator control
- Actuator configuration
- Actuator status visualization

Figure 34 describes the function of each component of the local operator interface.

Figure 34. Local Operator Interface Components

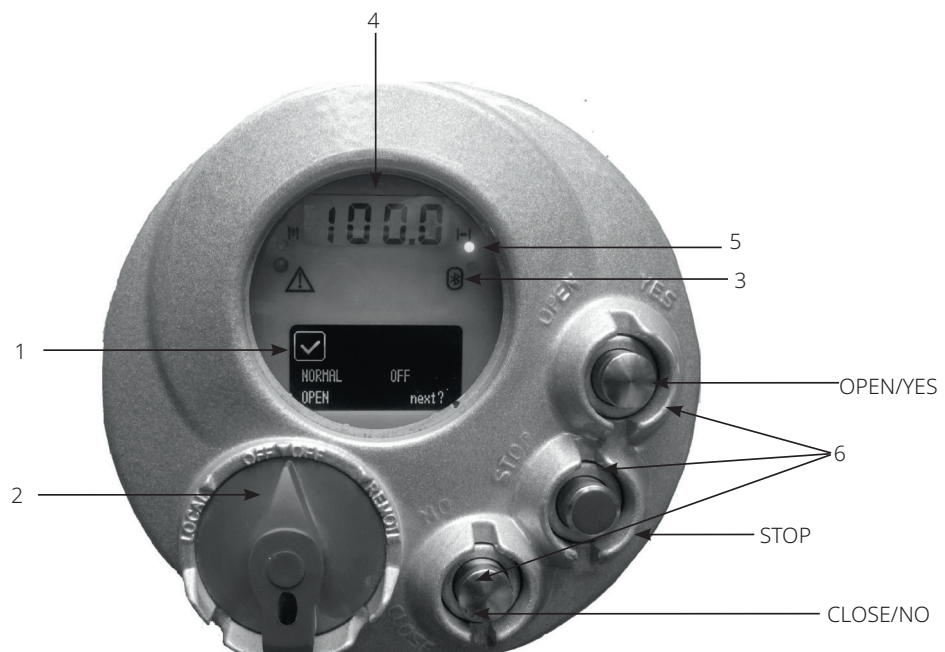

1. **OLED Graphic display:** during normal operation, the alphanumeric display shows the present status (NORMAL, ESD ON, ALARMS, WARNINGS, INTERLOCK, INT.EFS, SLEEP, EFS OFF, PST ON), the 3-position selector status (LOCAL, OFF, REMOTE) and the actuator action (OPEN, OPENING, CLOSED, CLOSING, STOP or R% : xxx.x). If the local selector is in OFF or REMOTE, pressing the YES push-button allows the user to scroll through the list of variables, alarms and reports:

—	output torque	mot temp
—	motor speed	term temp
—	main voltage	log status
—	current	wireless report
—	temperature	node report *
—	time	FDI report *
—	date	base report
—	alarm	term report
—	warning	Ain/Aout report *
—	Ktemp	

The data with * are only present if the relevant modules are present.
2. **3-position selector** to set the following operation modes:
 - LOCAL: for local control only
 - OFF: no control is active but the actuator is still connected to the mains
 - REMOTE: for remote control only
3. The F01-3000 can be provided with a radiofrequency wireless connection based on a qualified **Bluetooth** class 1 module. This allows to establish a connection and exchange data with a PDA or PC with built-in Bluetooth technology. The following tasks can be wirelessly performed:
 - View and change configuration
 - Set maintenance function
 - Read maintenance data
 - Download new firmware to the F01-3000
 - The blue LED indicates that the communication with a host device is established
4. Numeric display to indicate the present valve position as a % of the opening. Display resolution in function of the actuator stroke turns:
 - From 2.8 to 5.5 turns = 1%
 - From 5.5 to 13.8 turns = 0.5%
 - From 13.8 to 27.7 turns = 0.2%
 - From 27.7 to 10,000 turns = 0.1%

5. **Three LED's** to indicate the actuator status according to the following logic:
- green ON / red OFF: the actuator is stopped in open position
 - green OFF / red ON: the actuator is stopped in closed position
 - green OFF / red flashing: the actuator is running in closing direction
 - green flashing / red OFF: the actuator is running in opening direction
 - green ON / red ON: the actuator is stopped in intermediate position
 - yellow ON: alarm
 - yellow flashing: warning

The above color combination is supplied as standard, but it may be changed (red with green, green with red and yellow with red), during actuator setting operations.

6. **Local controls:** OPEN/YES, CLOSE/NO and STOP pushbuttons. The STOP pushbutton resets any existing command and is active both in local and remote. If the 3-position selector is in LOCAL, the OPEN / YES and CLOSE / NO pushbuttons work as OPEN and CLOSE commands.

If the 3-position selector is in REMOTE or in OFF, the OPEN / YES and CLOSE / NO pushbuttons work as YES and NO to answer the prompt (next? OK? view?, change? exit?) of the alphanumeric display.

In OFF, the OPEN / YES and CLOSE / NO pushbuttons allow to scroll down the menu, to view and change the actuator configuration or to scroll the list of variables, status and alarms.

In REMOTE, the above pushbuttons allow scrolling the list of variables, status, alarms and reports but the actuator configuration cannot be viewed or changed.

Description of Variables and Reports

torque	output torque in % of the nominal torque stated in the NAMEPLATE menu
motor speed	RPM of electrical motor
main voltage	voltage (V) and frequency (Hz) of mains
current	current (A) absorbed by the motor
temperature	temperature (°C), inside the electronic compartment
time	present time
date	present date
alarm	list of present alarms (see Section 12.10, Diagnostic Messages)
warning	list of present warnings (see Section 12.10, Diagnostic Messages)
Ktemp	temperature factor
mot temp	temperature (°C) of the electrical motor
term temp	temperature (°C) inside the terminal board compartment
log status	data logger status (off, ready, in progress: E: event number - n° of memory cycle or R: sample number - n° of memory cycle)
wireless report	Bluetooth interface status (ready, not ready)
node report	report of bus interface card (only present if the bus card is present) (see the relevant instruction manual)
FDI report	report of FDI function (only present if the LonWorks bus card is present) (see the relevant instruction manual)
base report	base card report <ul style="list-style-type: none"> - card code - manufacturing week and year - electrical diagram, etc.
term report	terminal board card report <ul style="list-style-type: none"> - card code - manufacturing week and year - electrical diagram, etc.
Ain/Aout report	Ain/Aout card report (only present if the card is present) <ul style="list-style-type: none"> - card code - manufacturing week and year - electrical diagram, etc.

The warning condition occurs when a variable reaches a critical value and/or a maintenance action is required, but the actuator control functions are still available. The alarm condition occurs when a variable is out of the acceptable range and the actuator control functions are not available.

The alarm and warning lists only contain the present alarms and warnings. When the fault condition disappears, the corresponding alarm or warning disappears from the list. A reset routine is provided to clear the type of alarm/warning that are memorized (over-torque, jammed valve, etc.).

Figure 35 shows the use of the OPEN/YES, CLOSE/NO and STOP pushbuttons in function of the local selector position.

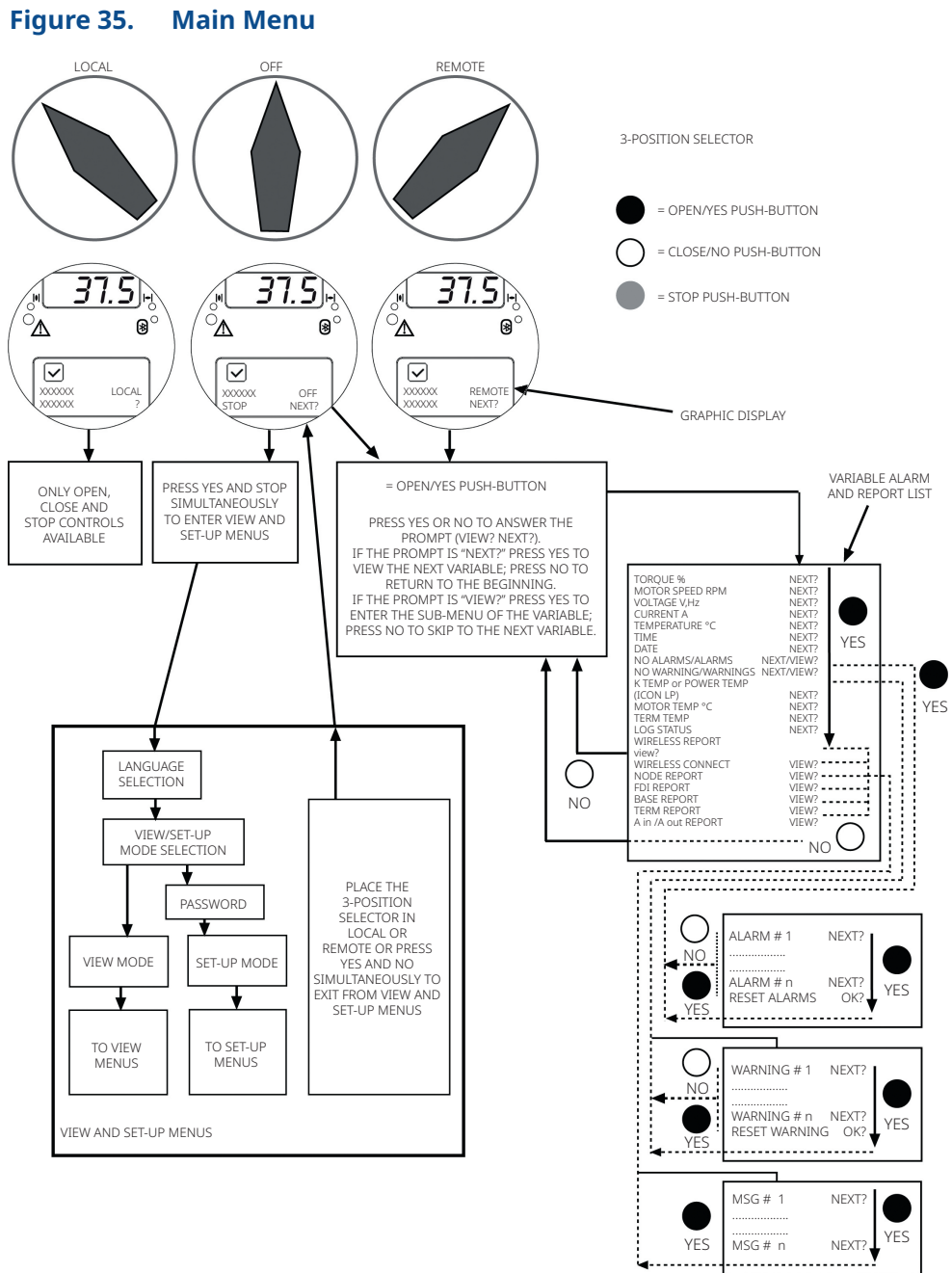

6.2 Configuration Options

The F01-3000 actuator can be totally configured from the local interface by means of a series of menus that can be selected from the alphanumeric display. The operator is guided through the different displays by answering YES or NO to the appropriate prompt (change? OK?, view?, next?, etc.) in the right corner of the lower row of the alphanumeric display.

To access the menus: set the local selector in OFF and then simultaneously press OPEN/YES and STOP. The alphanumeric display will now show the present language. Press YES if the language is correct, press NO to scroll the list of available languages and then YES to select. Press YES to when the menu reaches the desired language.

After choosing the language, the next step is the selection among view and set-up mode. Use "View" mode to see the actuator configuration and use "Set-up" mode to change the present configuration. Unauthorized access to the set-up mode is prevented by a 4-character alphanumeric password. The actuator is supplied by Biffi with the default password "0 0 0 0".

Once the correct password has been entered, the actuator parameters can be configured. The present password can also be modified by the "set password" routine in the Maintenance menu. After entering the new password, the old one ceases to be valid, so it is important to record the password in a secure location for future retrieval.

The configuration functions (view and set-up mode) are grouped in 4 main menus: Actuator set-up, Nameplate, Valve data, Maintenance.

Actuator set-up

This menu includes the routines that allow the actuator to be configured according to the requested control mode and to the valve it is mounted on.

- stroke limits
- torque set-up
- ESD set-up
- PST set-up
- remote controls
- local controls
- output relays
- positioner *
- fail-safe *
- out 4 to 20 mA *
- interlock
- 2-speed timer
- Bus *
- miscellaneous

The routines with * are only available if the relevant modules are present. If bus interface is LonWorks, the "BUS" routine changes to "FDI control".

Nameplate

This menu includes a series of data identifying the actuator characteristics, service and utilization mode. The data are entered by the manufacturer and can only be viewed (i.e., this menu is only available in View mode).

List of routines:

- serial number
- actuator type
- torque/thrust
- actuator speed
- power supply
- motor data
- test date
- wiring diagram
- enclosure
- certificate
- lubricant
- revision
- torque sensor

Valve data

This menu includes a series of data relevant to the valve. The valve manufacturer and end user should enter the data.

List of routines:

- tag name (maximum 28 characters)
- manufacturer (maximum 28 characters)
- break OP torque (maximum 28 characters)
- serial number (maximum 28 characters)
- break CL torque (maximum 28 characters)
- maximum stem thrust (maximum 28 characters)
- flange type (maximum 28 characters)

Maintenance

This menu includes all diagnostic and historic data which can help the operator in case of failure or during maintenance operations. The Maintenance menu also includes the "Set password" routine.

List of routines:

- Set-up mode
 - set new password
 - clear alarm log
 - set torque profile reference
 - set torque curve reference
 - clear recent data log
 - configuration (backup/restore)
 - set maintenance date
 - set data logger
 - PST reference (only if INTERLOCK = ADVANCED)
 - PST cmd (only if INTERLOCK = ADVANCED)
- View mode
 - alarm log
 - torque profile
 - torque curve
 - operation log
 - maintenance date
 - data logger

The parameters appear on the alphanumeric display in the same order both in view and set-up mode. At the end of each routine the program will automatically return to the beginning of the routine and the operator can choose to either re-enter (by pressing YES) or to move on to a next routine (by pressing NO).

6.3 Entering the View Mode

The existing actuator configuration should be checked before commissioning. The parameters are configured in factory according to a standard setting or to customer requirements. In view mode, no password is requested, but no change of parameters can be made.

- Ensure the electrical main power is applied.
- Move the 3-position selector to OFF and then simultaneously press OPEN/YES and STOP.
- The display shows the present language. Press YES to confirm or NO to scroll the list of available languages. Press YES to select a new language. Press YES to confirm.
- Press NO to scroll the list of available menus (actuator set-up, nameplate, valve data, maintenance) and then press YES to select the desired menu.
- Press NO to scroll the list of available routines and press YES to select the routine where the parameter to be changed is located.
- Press NO to scroll the list of parameters and press YES to view the value.

6.4 Entering the Set-Up Mode

To change the existing settings or to set the stroke limits, it is necessary to enter the correct password.

- Ensure the electrical main power (or the external auxiliary supply) is applied.
- Move the 3-position selector to OFF and then simultaneously press OPEN/YES and STOP.
- The display shows the present language. Press YES to confirm or NO to scroll the list of available languages. Press YES to select. Press YES to confirm the chosen language.
- Press NO when the message is "VIEW MODE OK?". Press YES to answer prompt "ENTER PASSWORD OK?".
- Enter password. Enter one digit at a time. Press YES if digit is correct, press NO to scroll the list of available characters and then press YES when the character is correct. Enter 4 digits. After entering the last digit, the microprocessor checks the password. If it is correct the messages "PASSWORD CORRECT" and then "SET-UP MODE OK?" appear. Press YES.
- Press NO to scroll the list of available menus (actuator set-up, valve data, maintenance) and press YES to select the desired menu.
- Press NO to scroll the list of available routines and press YES to select the routine where the parameter to be changed is located.
- Press YES and NO to answer the prompt on the display and change the parameter.
- If the password is wrong the message "PASSWORD WRONG" appears and set-up mode will not available.

All settings are automatically saved to a non-volatile memory and retained also if the electrical power is removed from the actuator. All F01-3000 actuators are configured before shipping with a standard default setting unless alternatives were requested on order. In case of difficulty during commissioning, the default setting can be re-instated by the appropriate function in the routine "miscellaneous" of the actuator set-up menu. The actuator returns to its original configuration and commissioning can be resumed.

6.5 Exit from View and Set-Up Mode

The following conditions cause the exit from view and set-up mode:

- Move the 3-position selector to LOCAL or REMOTE.
- Answer YES when the display asks "EXIT OK?".
- Press YES and NO simultaneously.
- Automatic exit after 90 minutes without any parameter change or view.
- Remove the electrical power from the unit.

Figure 36 shows the procedure to enter view and set-up mode.

Figure 36. Enter View and Set-Up Mode

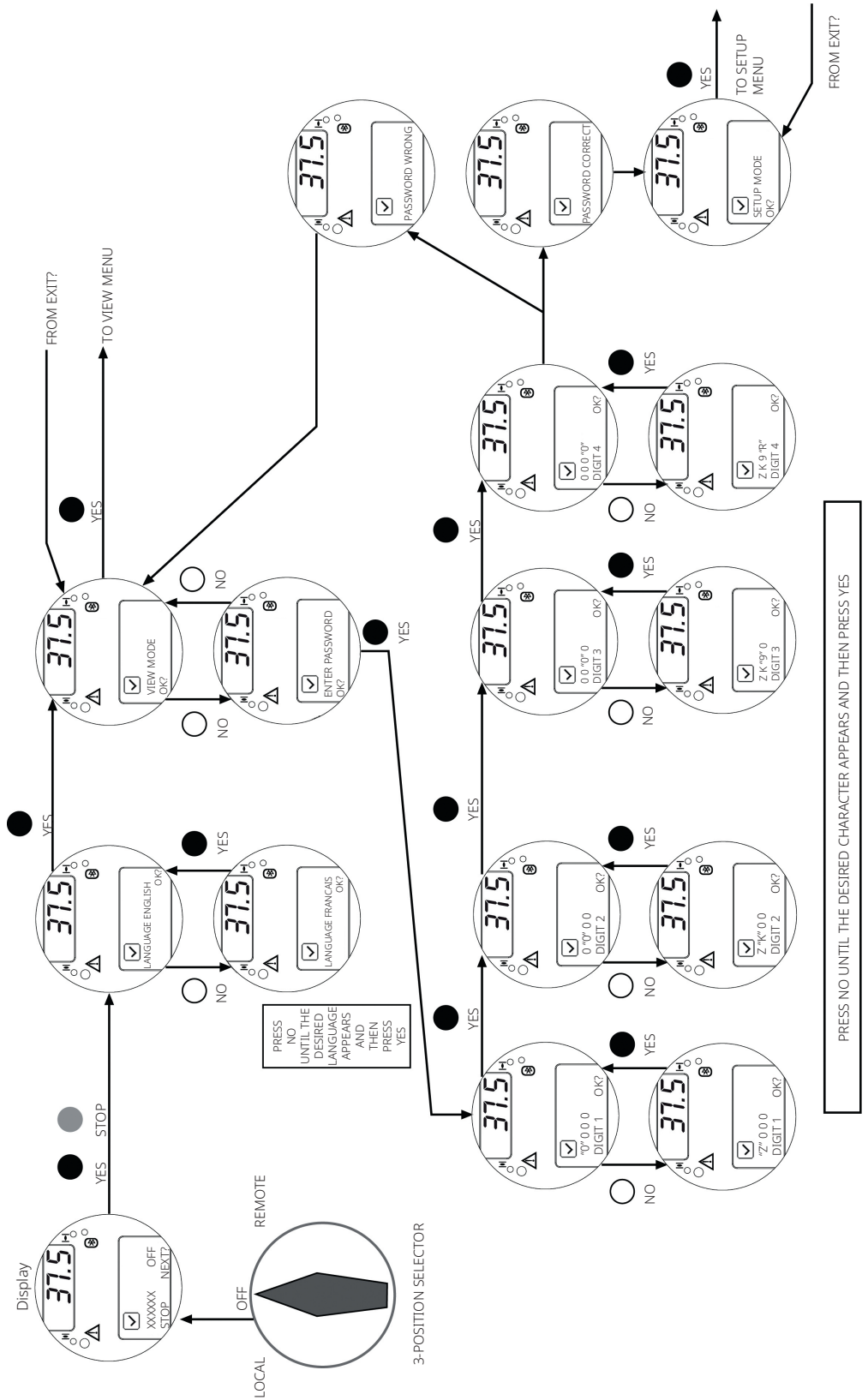

Section 7: Set-Up Menu

Figure 37. Set-up Menu

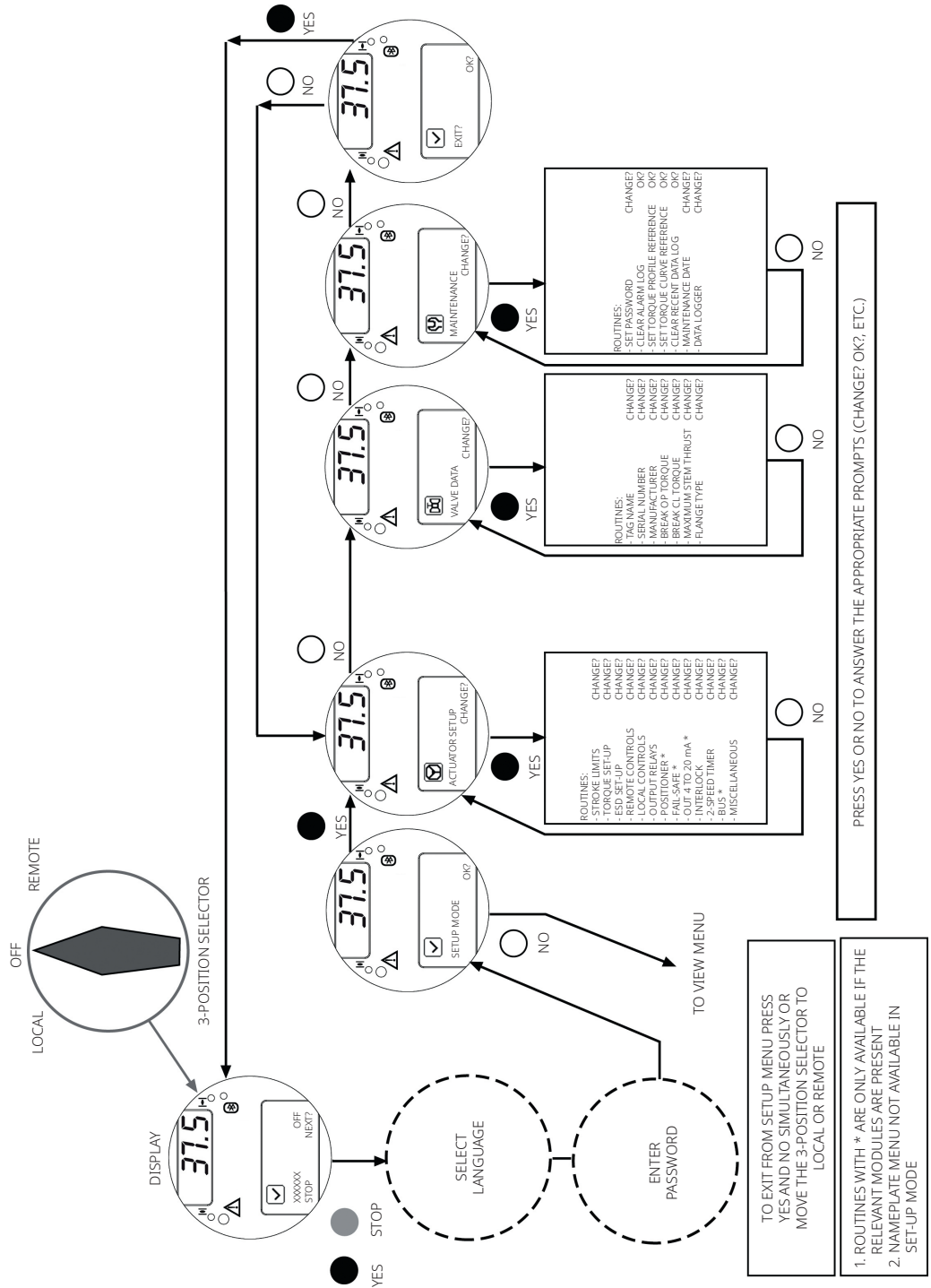

Section 8: View Menu

Figure 39. View Menu

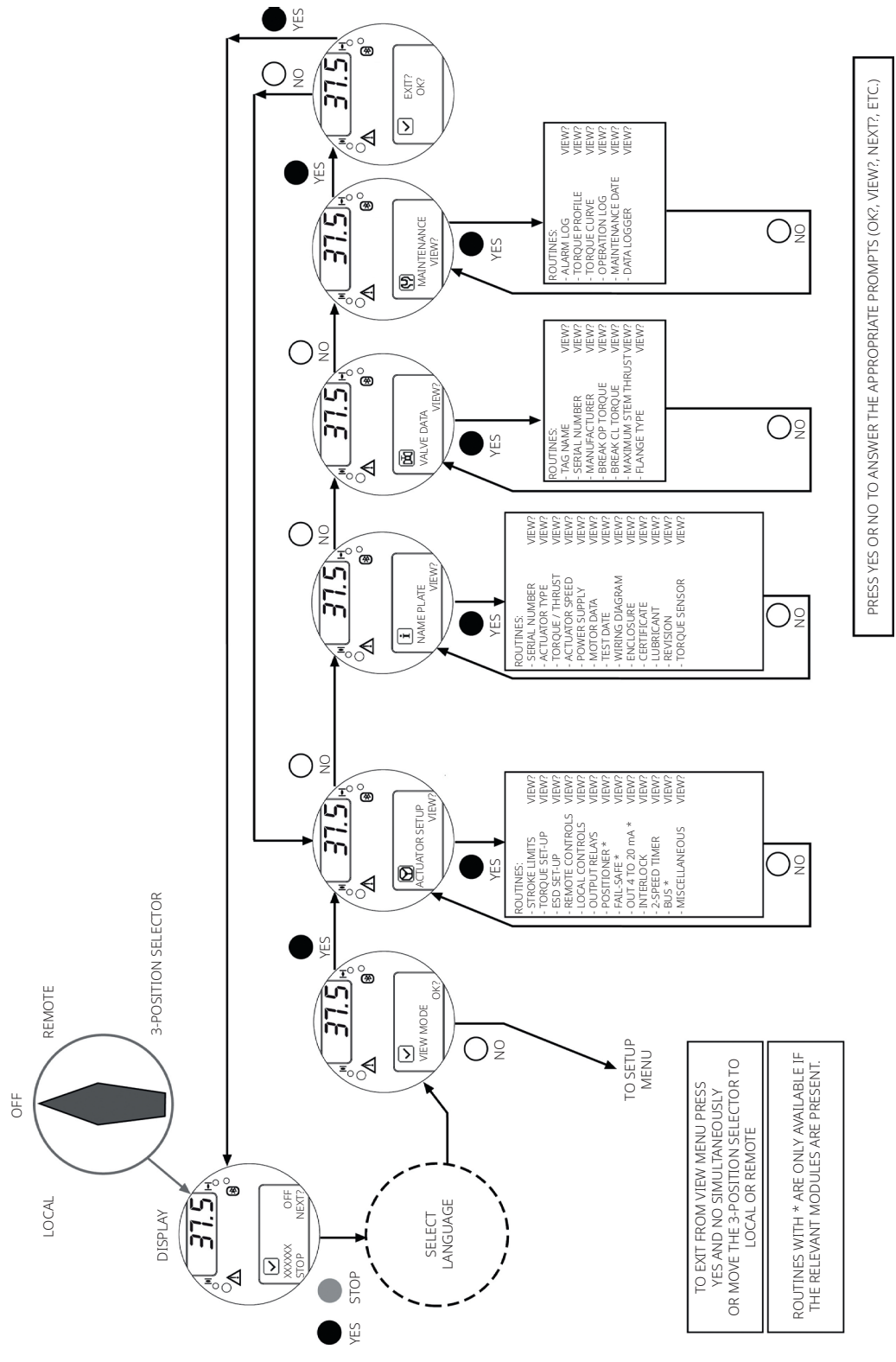

The Figure 40 shows the procedure to move in the view routines.

Figure 40. View Menu

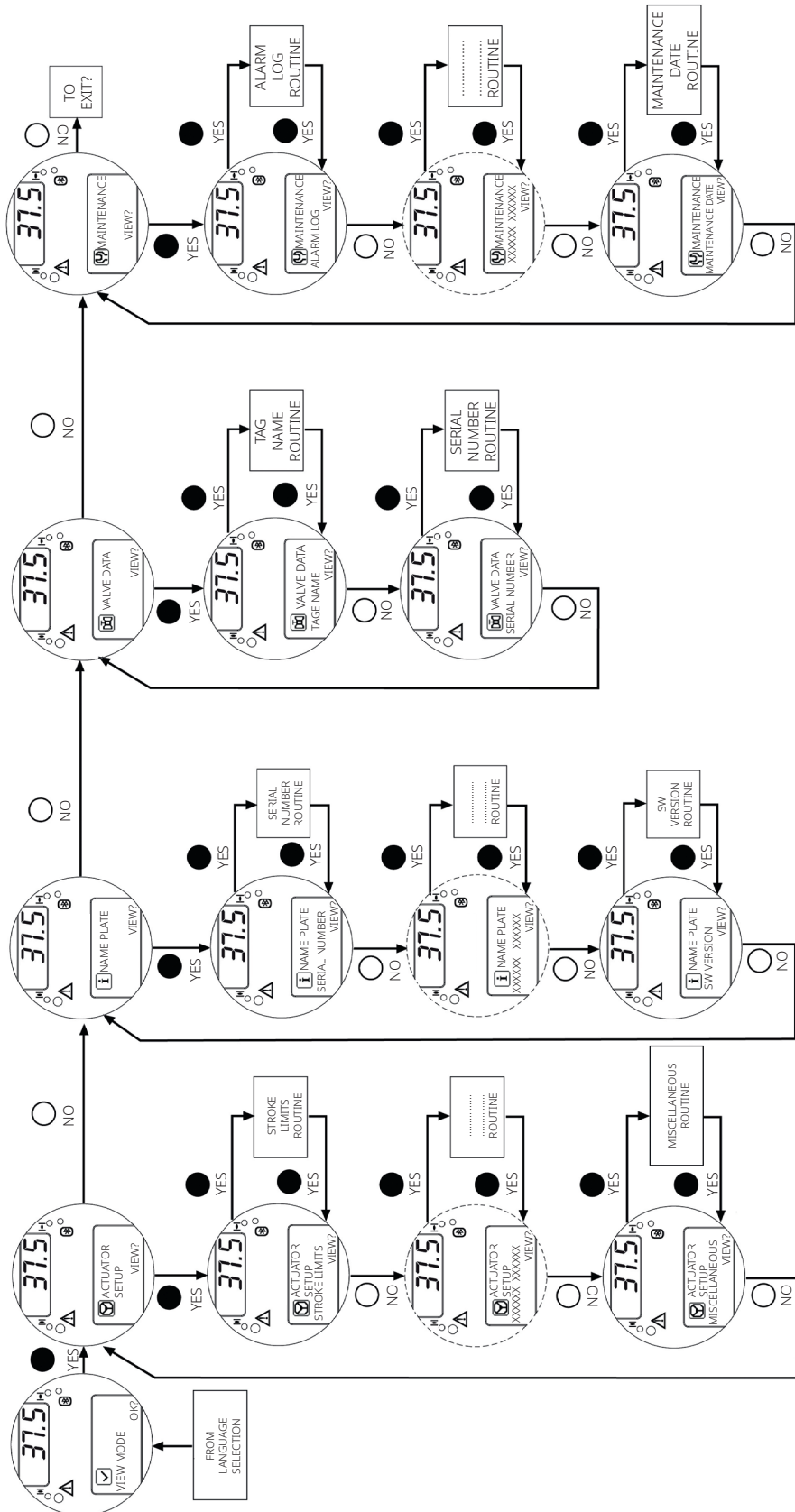

Section 9: Set-Up Routines

9.1 Actuator Set-Up

9.1.1 Set Stroke Limits

This routine allows the actuator to be configured according to the type of valve it is mounted on.

The following parameters will be set:

- Opening and closing torque limits: from 40% to 100% of the nominal torque. The nominal torque corresponding to 100% is set in-house and is stated in the nameplate menu for reference.
- Close direction: clockwise (CW) or counterclockwise (CCW). Most valves require clockwise rotation of the stem when viewed from the handwheel. Engage the manual override and check if the valve closes with clockwise or counterclockwise rotation of the handwheel.
- Close and open limits type: by position or by torque. Use the table below to choose.

Set-up procedure

- Engage the manual override and move the valve to the mid-travel position.
- Move the local selector to OFF and then simultaneously press OPEN and STOP. Select the language and then enter the password according to the instructions (see "Entering the set-up mode"). When the message displayed is "SET-UP MODE OK?" press YES. Press YES to select the actuator set-up menu and then press YES again to start with the stroke limits routine.
- Press YES if the closing torque limit is correct or NO to scroll the list of available values. When the value is correct, press YES.
- Press YES if the opening torque limit is correct or NO to scroll the list of available values. When the value is correct press YES.
- Press YES if the rotation to close is correct (CW or CCW) or NO to change. When the value is correct press YES.
- Press YES to set the close limit or NO and then YES to set the open limit.

Close limit type

Press YES if the close limit type is correct (torque or position), press NO to change it. Press YES when the type is correct.

Close limit by position

- Move the local selector to LOCAL. The local controls can be used.
- Move the valve to closed position (by CLOSE control or by handwheel).
- Move the local selector to OFF.
- Press YES to confirm.
- Press YES to continue with the open limit setting or press NO and again NO to repeat the close limit setting procedure. Press NO and then YES to exit from the stroke limits routine.

Close limit by torque

- Move the local selector to LOCAL. The local controls can be used.
- Press the CLOSE control. The actuator moves in closing direction and when the configured torque value is reached the motor is stopped and the new position limit is memorized.
- Move the local selector to OFF.
- Press YES to confirm.
- Press YES to continue with the close limit setting or press NO and again NO to repeat the close limit setting procedure. Press NO and then YES to exit from the stroke limits routine.

Open limit type

Press YES if the open limit type is correct (torque or position), press NO to change it. Press YES to confirm.

Open limit by position

- Move the local selector to LOCAL. The local controls become active.
- Move the valve to open position (by OPEN control or by handwheel).
- Move the local selector to OFF.
- Press YES to confirm.
- Press YES to exit or press NO and then YES to repeat the close limit setting procedure.

Open limit by torque

- Move the local selector to LOCAL. The local controls become active.
- Press the OPEN control. The actuator moves in opening direction and when the configured torque value is reached the motor is stopped and the new position limit is memorized.
- Move the local selector to OFF.
- Press YES to confirm.
- Press YES to exit or press NO and then YES to repeat the close limit setting procedure.

If parameter "direction to close" is changed, both limits (open and close) must be set. Before leaving the stroke limits routine, the microprocessor calculates the new value of the position resolution. If the stroke turns are less than 2.7, the message "error re-try" appears and the stroke limits procedure must be repeated.

9.1.2 Torque Set-Up

The output torque limits to close or to open may be configured between 40% and 100% of the nominal torque stated on the actuator nameplate.

Set-up procedure

- Move the local selector to OFF and then simultaneously press OPEN and STOP. Select the language and then enter the password according to the instructions (see "Entering the set-up mode"). When the message displayed is "SET-UP MODE OK?" press YES. Press YES to select the actuator set-up menu, press NO and then press YES to select the torque set-up routine.
- Press YES if the opening torque limit is correct, press NO to scroll the list of available values. Press YES when the value is correct.
- Press YES if the closing torque limit is correct, press NO to scroll the list of available values. Press YES when the value is correct.

Table 10. Torque Limit Settings

Valve Type	Close Limit	Open Limit
Gate (solid, flexible and split wedge), globe, metal seated butterfly valves	Torque	Position
Ball, gate (parallel slide), plug valves, rubber seated butterfly valves	Position	Position
Linear valves with back-seating on stem	Torque or position	Torque

9.1.3 ESD Control

An ESD signal can be connected to the actuator to override any existing command and drive the valve to a predetermined position. The ESD control is not self-maintained: the ESD action is only performed if the relevant input is active. The ESD control is active when the 3-position selector is in REMOTE and no alarm is present.

WARNING

The user may select ESD to override the situations indicated by (*). If these situations occur and if "ESD > ..." is configured, the actuator may be damaged. Therefore, selecting "ESD > ..." will invalidate the warranty.

Function "ESD priority" allows the ESD command to override the following additional situations: (*) motor thermostat alarm, (*) torque limit tripped, (*) local stop pressed, 3-position selector in local, 2-speed timer, (*) 3-position selector in OFF.

Configuration procedure

- Move the local selector to OFF and then simultaneously press OPEN and STOP. Select the language and then enter the password according to the instructions (see "Entering the set-up mode"). When the message displayed is "SET-UP MODE OK?" press YES. Press YES to select actuator set-up menu, press NO to scroll the list of available routines and then press YES to select ESD set-up.
- Press YES if the ESD action is correct or press NO to scroll the list of available options (off, open, close, stay-put, go to position xx %). Press YES to select the desired option.
- Press either YES or NO to select the signal type (present, absent).
- Press YES to change ESD priority with reference to the following signals or status:
 - (*) Motor thermostat alarm. Choosing ESD > THERMOSTAT, the ESD action will be carried out also in case of motor over-heating. Vice-versa, if ESD < THERMOSTAT was chosen, the ESD action will not be done in case of motor over-heating.
 - (*) Torque limit tripped. Choosing ESD > TORQUE LIMIT, the ESD action will be carried out also in case of torque alarm. Vice-versa, if ESD < TORQUE LIMIT was chosen, the ESD action will not be done in case of torque alarm.
 - (*) Local stop pressed. Choosing ESD > LOCAL STOP, the ESD action will override the local STOP signal. Vice-versa, if ESD < LOCAL STOP was chosen, the ESD action will not be performed if the local STOP pushbutton is pressed.
 - Local selector in LOCAL. Choosing ESD > LOCAL CONTROLS, the ESD action will be carried out also when the local selector is in LOCAL. Vice-versa, if ESD < LOCAL CONTROLS was chosen, the ESD action will not be performed if the 3-position selector is in LOCAL.
 - 2-speed timer. Choosing ESD > 2-speed timer, the 2-speed timer function will be inhibited during ESD action. Vice-versa, if ESD < 2-speed timer was chosen, the 2-speed timer function will be active during ESD action.
 - (*) Local selector in OFF. By choosing ESD > OFF, the ESD action will be carried out also when the local selector is in OFF. Vice-versa, if ESD < OFF was chosen, the ESD action will not be performed if the 3-position selector is in OFF.

The factory configuration is the following: action: CLOSE, signal type: PRESENT, priorities: ESD > LOCAL CONTROLS, ESD > 2-SPEED TIMER, ESD < all other cases.

9.1.4 Remote Controls

The actuator may be remotely controlled by 4, 3 or 2 wires depending on the connection made on the terminal board of the actuator. The following options are available:

- 4 wires latched: requires 2 momentary signals (since the control is self-maintained) to open or close and one signal to stop in mid-travel. The action of the stop signal can be reversed (stop when signal is On [MAKE] or stop when signal is Off [BREAK]).
- 3 wires latched instant reverse: requires 2 momentary signals (since the control is self-maintained) to open or close. Reverse momentary signal reverses the direction.
- 3 wires momentary: requires 2 push-to-run type signals (since the control is not self-maintained) to open or close.
- 2 wires open if signal On: requires signal On to open and no signal to close.
- 2 wires open if signal Off: requires signal Off to open and signal On to close.

By selecting the option Off, the remote controls are disabled. Configuration should be done during actuator set-up.

Configuration procedure

- Move the local selector to OFF and then simultaneously press OPEN and STOP. Select the language and then enter the password according to the instructions (see "Entering the set-up mode"). When the message displayed is "SET-UP MODE OK?" press YES. Press YES to select actuator set-up menu, press NO to scroll the list of available routines and then press YES to select Remote controls.
- Press YES if the control mode is correct or NO to scroll the list of available options: 4 wires, 3 wires, 2 wires, off. Press YES to select the desired option. If 4 wires was chosen use YES and NO to select the STOP signal: set MAKE to stop when signal is on and set BREAK to stop when signal is off. If "3 wires" was chosen, use YES or NO to answer the prompt on the display and choose among "push-to-run" or "latched instant reverse" control modes. If "2 wires" was chosen, use YES and NO to choose among "open if signal ON" or "open if signal OFF" control modes.

9.1.5 Local Controls

This routine allows:

- To configure the control mode by means of the local controls when the 3-position selector is in LOCAL. The available options are "push-to-run", "latched", "latched with instant reverse".
- To set the LED's color. The following options are available: open LED: green or red; close LED: green or red; alarm LED: yellow or red.

Configuration procedure

- Move the local selector to OFF and then simultaneously press OPEN and STOP. Select the language and then enter the password according to the instructions (see "Entering the set-up mode"). When the message displayed is "SET-UP MODE OK?" press YES. Press YES to select the actuator set-up menu, press NO to scroll the list of available routines and then press YES to select Local controls.
- Press YES to change control mode or press NO to proceed to LED's color setting.

Control mode

Press YES if the display shows the correct control mode or press NO to scroll the list of available options (push-to-run, latched). Press YES to confirm. Option "push-to-run rel. AS5-6" is used when a remote enabling of local commands is required. With the local selector in LOCAL, pressing the OPEN or CLOSE local pushbuttons causes relays AS5 or AS6 to switch, but no command is sent to motor. The control PLC should read the status of the above-mentioned relays and send an open or close command on the remote inputs (see Section 5.7, push-to-run mode; see relevant electrical diagram when the option is used).

LED's color

- Press YES if the color of the open LED is correct. Press NO to change it, then YES to confirm.
- Press YES if the color of the close LED is correct. Press NO to change it, then YES to confirm.
- Press YES if the color of the alarm LED is correct. Press NO to change it, then YES to confirm.

9.1.6 Output Relays

Monitor relay

The voltage-free, change-over, contacts of the monitor relay indicate that the actuator is either available for remote control or that a problem or a condition preventing remote control of the valve exists.

The monitor relay is normally energized and will be de-energized on:

- main voltage failure
- lost phase
- internal temperature alarm
- K1 contactor failure
- K2 contactor failure
- position sensor failure
- speed sensor failure
- configuration error
- HW error
- mid-travel alarm
- request signal (available if positioner enabled and request from 4 to 20 mA)

The following situation can be configured individually to switch-over the monitor relay:

- motor over-temperature
- over-torque
- jammed valve
- LOCAL/OFF selected
- manual operation
- ESD signal on (ESD-EFS)
- low lithium battery (if present)
- LOCAL/STOP pressed

Auxiliary output relays

For status indication or diagnostic purposes, 8 voltage-free contacts of 8 relays are available to be configured individually to switch for the following conditions:

Status

- open limit
- closed limit
- position \geq xx %
- position \leq xx %
- closing
- opening
- motor running
- blinker
- mid-travel position
- local selected
- remote selected
- local stop active
- ESD/PST-efs
- manual operation
- interlock PST-icon
- heater (only AS8)

Alarm

- motor over-temperature
- over-torque
- over-torque in OP
- over-torque in CL
- valve jammed
- valve jammed in OP
- valve jammed in CL
- low lithium battery (if present)
- mid travel alarm in CL/OP
- mains-only AS8

Warning

- warnings
- PST failed (i.e., Partial Stroke Test failure)

The contacts may be configured to make or break on condition.

Configuration procedure

- Move the local selector to OFF and then simultaneously press OPEN and STOP. Select the language and enter the password according to the instructions (see "Entering the set-up mode"). When the message displayed is "SET-UP MODE OK?" press YES. Press YES to select actuator set-up menu, press NO to scroll the list of available routines and then press YES to select Output relays.
- Press YES to select DEFAULT #1 or press NO to change.
- Press YES to select DEFAULT #2 or press NO to configure the output relays.

Default #1

Monitor relay

- main voltage failure
- lost phase
- local/off selected
- local stop pressed
- manual operation
- internal temperature alarm
- K1 contactor failure
- K2 contactor failure
- position sensor failure
- speed sensor failure
- configuration error
- HW error
- motor over-temperature
- over-torque
- jammed valve
- low lithium battery (if present)
- mid-travel alarm

Auxiliary relays

AS1: open limit; make
AS2: close limit; make
AS3: position >90%; make
AS4: position <5%; make
AS5: motor running; make
AS6: over-torque; make
AS7: ESD active; make
AS8: motor overtemperature

Default #2

Monitor relay

- main voltage failure
- lost phase
- local/off selected
- local stop pressed
- manual operation
- internal temperature alarm
- K1 contactor failure
- K2 contactor failure
- position sensor failure
- speed sensor failure
- configuration error
- HW error
- motor over-temperature
- over-torque
- jammed valve
- low lithium battery (if present)
- mid-travel alarm

Auxiliary relays

AS1: open limit; break

AS2: close limit; break

AS3: position >90%; break

AS4: position <5%; break

AS5: motor running; make

AS6: remote selected; make

AS7: warning; make

AS8: local selected

Configure output relays

Press YES to change the monitor relay or NO to change auxiliary relays AS1, 2, 3, 4, 5, 6, 7 and 8.

Monitor relay

Press YES or NO to enable or disable the following situations from the conditions which de-energize the monitor relay: motor over-temperature, over-torque, jammed valve, manual override, ESD signal on, low lithium battery (if present), local STOP pressed, LOCAL/OFF selected.

Auxiliary relays AS1, 2, 3, 4, 5, 6, 7 and 8

- Press NO to answer prompt "MONITOR RELAY change?".
- Press YES to change AS1, press NO to select the other relays.
- Press YES if the condition associated to AS1 relay is correct, press NO to scrolls the list of conditions and press YES to set.
- Press YES or NO to either confirm or change the type of contact when the condition occurs (break, make). Since relay AS8 is change-over, this option is not available.
- Press NO to pass to AS2 and then repeat the procedure for the other relays.
- Press NO to exit.

9.1.7 Positioner

The positioning function is only available in inching or modulating F01-3000 actuators and allows to position the valve according to a "position request R%" command signal.

The positioning function compares the present actuator position % with the position request R% and if the difference is greater than the dead band the actuator is driven to reach the new requested position.

The "position request R%" signal may either be received from the bus or the 4 to 20 mA analog input. If the F01-3000 is set to receive the position request R% from the bus, a fieldbus interface card must be present or a Hardware alarm will be generated. If the F01-3000 is set to receive the position request R% from the 4 to 20 mA generator, the Ain/Aout card must be present or a Hardware alarm will be generated.

The following options can be configured via local operator interface:

- Dead band: configurable from "position resolution%" to 25.5% of the maximum position error. The configured value should be great enough to avoid the hunting effect.
- Polarity of the 4 to 20 mA position request signal: it allows to reverse the relationship between the 4 to 20 mA input signal and the "position request R%", according to the following diagrams. The option is not available when the F01-3000 is set to receive the "position request R%" from the bus.
- Motion inhibit time: it allows to adjust the length of the delay time between two cycles of the motor. It can be configured from 1 to 255 s and allows to set the maximum number of start/hour of the electrical motor.
- % MINIMUM and % MAXIMUM, 4 to 20 mA input signal range: it allows to change the relationship between the input signal and the position request R%. This function is useful when a single 4 to 20 mA signal is used to control the position of 2 valves (e.g., split range applications). The option is not available when the F01-3000 is set to receive the "position request R%" from the bus.

Figure 41. Analog Input Setting

Figure 42 may better clarify the above option:

Example A

With input signal = 4 mA, the position request is 0% and the actuator is driven to close. With input signal = 20 mA, the position request is 100% and the actuator is driven to open. With input signal = 12 mA the position request is 50% and the actuator is driven to reach position 50%.

Example B

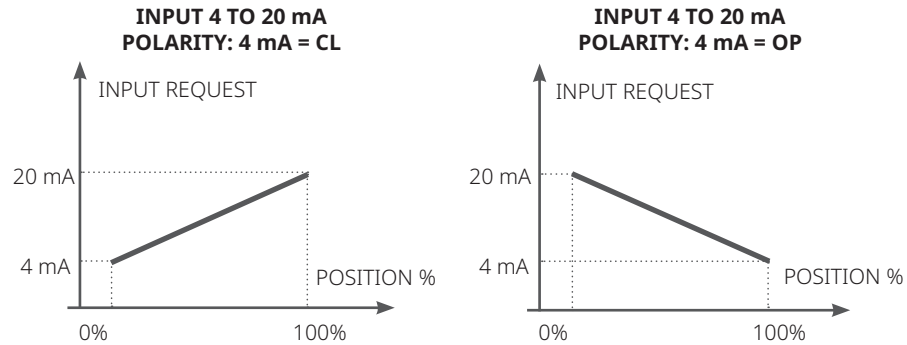
With input signal < 8 mA, the position request is 0% and the actuator is driven to close. With input signal = 16 mA, the position request is 100% and the actuator is driven to open. With input signal = 12 mA the position request is 50% and the actuator is driven to reach position 50%.

Example C

With input signal = 4 mA, the position request is 100% and the actuator is driven to open. With input signal = 20 mA, the position request is 0% and the actuator is driven to close. With input signal = 12 mA the position request is 50% and the actuator is driven to reach position 50%.

Example D

With input signal < 8 mA, the position request is 100% and the actuator is driven to open. With input signal = 16 mA, the position request is 0% and the actuator is driven to close. With input signal = 12 mA the position request is 50% and the actuator is driven to reach position 50%.

Figure 42. Analog Input Setting

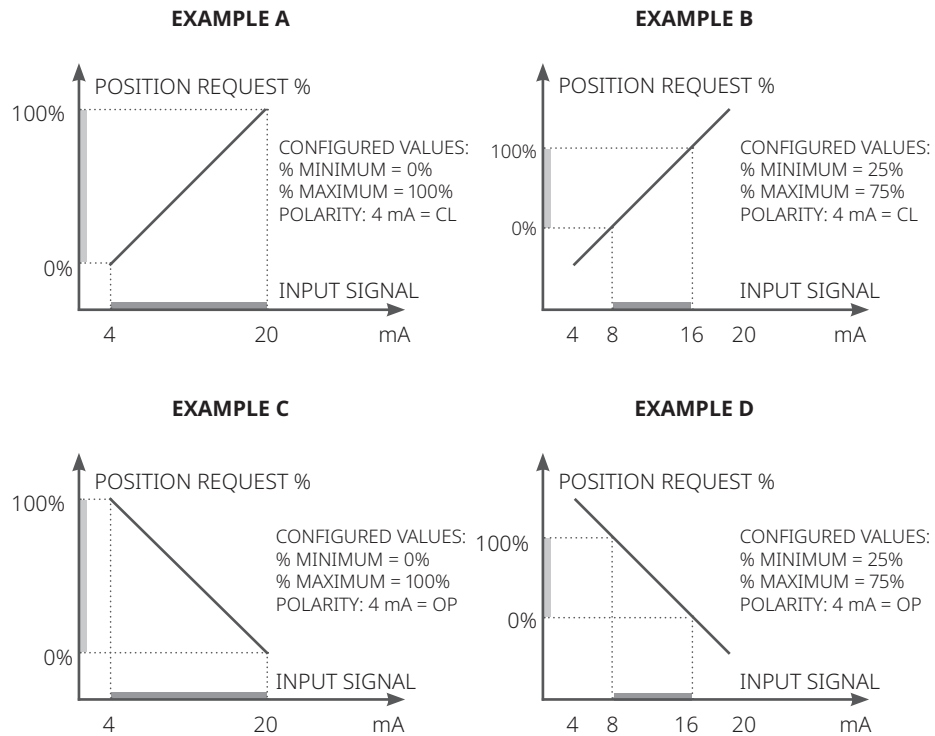

Configuration procedure

- Move the local selector to OFF and then simultaneously press OPEN and STOP. Select the language and then enter the password according to the instructions (see Entering the set-up mode). When the message displayed is "SET-UP MODE OK?" press YES. Press YES to select the actuator set-up menu, press NO to scroll the list of available routines and then press YES to select POSITIONER.
- Press YES if the configured value of the Dead Band is correct (from "position resolution %" to 25.5%) or press NO to change it, then press YES.
- Press YES if the configured value of the Polarity is correct (4 mA=CL or 4 mA=OP) or press NO to change it, then press YES.
- Press YES if the configured value of the Motion Inhibit Time is correct (from 1 to 255 s) or press NO to change it, then press YES.
- Press YES if the configured value of the % MINIMUM is correct (from 0 to 75%) or press NO to change it, then press YES. The standard value is 0.
- Press YES if the configured value of the % MAXIMUM is correct (from 25 to 100%) or press NO to change it, then press YES. The difference between % MAXIMUM and % MINIMUM should be greater than 25%. The standard value is 100.

9.1.8 Fail-safe

This function configures the actuator action in case of loss of the 4 to 20 mA input or bus signals. This action only takes place if the local selector is in REMOTE and if the positioning function or the bus interface are active. When the 4 to 20 mA or bus signal is restored, the F01-3000 resumes its normal functioning. The Interlock and ESD controls override the fail-safe action according to Figure 43.

Figure 43. Fail-safe Priority

OP/CL CONTROLS	FAIL-SAFE ACTION	INTERLOCKS	ESD
LOWEST PRIORITY		HIGHEST PRIORITY	

The following options can be configured:

- Action: open, close, stay-put, go to position %, no action (OFF).
- Delay: time before than the Fail-safe action takes place.

Configuration procedure

- Move the local selector to OFF and then simultaneously press OPEN and STOP. Select the language and then enter the password according to the instructions (see entering the set-up mode). When the message displayed is "SET-UP MODE OK?" press YES. Press YES to select the actuator set-up menu, press NO to scroll the list of available routines and then press YES to select FAIL-SAFE.
- Press YES if the configured ACTION is correct (open, close, stay-put, go to position xxx%, off) or press NO to change it, then press YES.
- Press YES if the configured value of the DELAY is correct (from 0 to 255 s) or press NO to change it, then press YES.

9.1.9 Out 4 to 20 mA

This routine is only available if the Ain/Aout card is present. With this card the F01-3000 is provided with a 4 to 20 mA analog input and a 4 to 20 mA analog output.

The 4 to 20 mA output can be configured to provide a current proportional to either "position" or "torque". The polarity option allows to reverse the relationship between the present position or torque and the 4 to 20 mA output signal, according to Figure 44.

Figure 44. Analog Output Setting

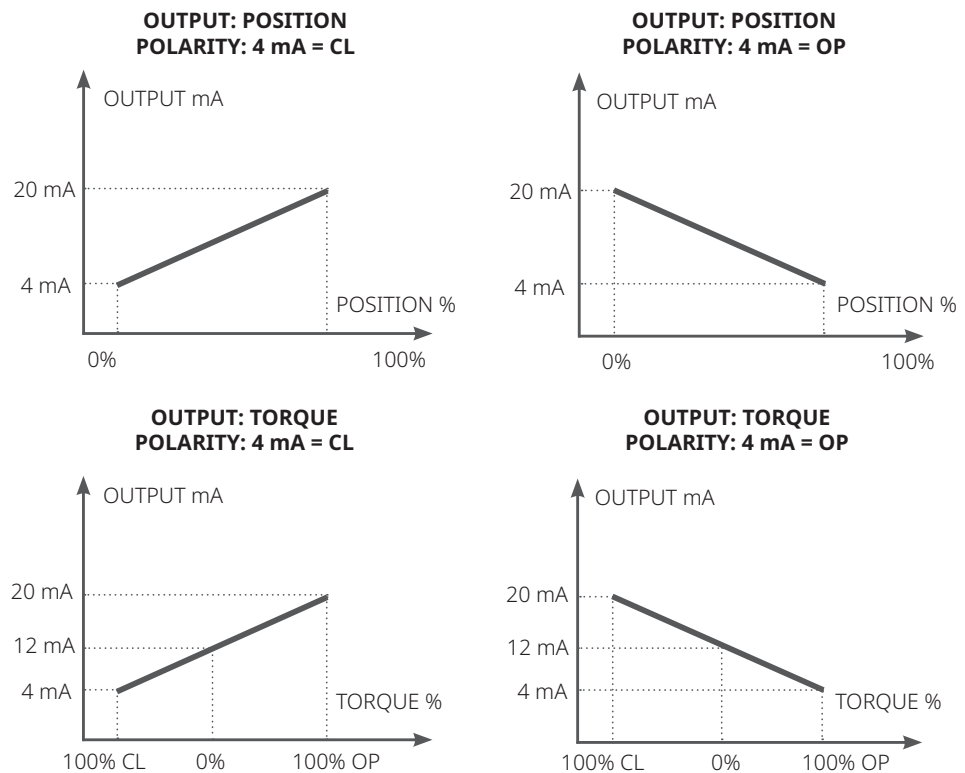

Configuration procedure

- Move the local selector to OFF and then simultaneously press OPEN and STOP. Select the language and then enter the password according to the instructions (see "entering the set-up mode"). When the message of the display is "SET-UP MODE OK?" press YES. Press YES to select the actuator set-up menu, press NO to scroll the list of available routines and then press YES to select Out 4 to 20 mA.
- Press YES if the output is correct (POSITION or TORQUE) or press NO to change it, then press YES.
- Press YES if the polarity is correct or press NO to change it, then press YES.

9.1.10 Interlock

The interlock inputs can be used to inhibit the actuator movement in open or close direction. The controls are momentary, the inhibit action continues until the relevant signal is present. The interlock controls work when the local selector is in LOCAL or in REMOTE. The ESD control overrides the interlock controls. The following options can be configured:

- Interlock OP: active when signal is PRESENT, active when signal is ABSENT, no action (OFF).
- Interlock CL: active when signal is PRESENT, active when signal is ABSENT, no action (OFF).

Configuration procedure

- Move the local selector to OFF and then simultaneously press OPEN and STOP. Select the language and then enter the password according to the instructions (see entering the set-up mode). When the message displayed is "SET-UP MODE OK?" press YES. Press YES to select the actuator set-up menu, press NO to scroll the list of available routines and then press YES to select INTERLOCK.
- Press YES if the configured value of the Open Interlock is correct (PRESENT, ABSENT, OFF) or press NO to change it, then press YES.
- Press YES if the configured value of the Close Interlock is correct (PRESENT, ABSENT, OFF) or press NO to change it, then press YES.

9.1.11 2-Speed Timer

The "2-speed timer" routine is used to extend the actuator travelling time in opening and/or closing direction, by driving the motor by pulses which duration (ON and OFF time) is configurable. Pulsing control can be applied to full travel or only a part of it.

Start position and stop position may be adjusted from 0 to 100% separately in opening and closing direction.

ON time and OFF time may be adjusted from 1 to 200 s separately in opening and closing direction.

Configuration procedure

- Move the local selector to OFF and then simultaneously press OPEN and STOP. Select the language and then enter the password according to the instructions (see "Entering the set-up mode"). When the message displayed is "SET-UP MODE OK?" press YES. Press YES to select actuator set-up menu, press NO to scroll the list of available routines and then press YES to select 2-speed timer.
- Press YES to change close direction parameters, press NO and then YES to change only open direction parameters.

Closing direction

- Press YES if the status is OK or NO to change. Press YES to confirm (status = On, enables 2-speed timer operation in closing direction status = Off, disables timer operation in closing direction).
- Press YES if the position value where pulsing control starts is correct, press NO to scroll the list of available values. Press YES when the value is correct.
- Press YES if the position value where pulsing control stops is correct, press NO to scroll the list of available values. Press YES when the value is correct.
- Press YES if the value of the ON time of pulsing control is correct, press NO to scroll the list of available values. Press YES when the value is correct.
- Press YES if the value of the OFF time of pulsing control is correct, press NO to scroll the list of available values. Press YES when the value is correct.

Opening direction

- Press YES if the status is OK or NO to change. Press YES to confirm (status = On enables 2-speed timer operation in opening direction status = Off, disables timer operation in opening direction).
- Press YES if the position value where pulsing control starts is correct, press NO to scroll the list of available values. Press YES when the value is correct.
- Press YES if the position value where pulsing control stops is correct, press NO to scroll the list of available values. Press YES when the value is correct.
- Press YES if the value of the ON time of pulsing control is correct, press NO to scroll the list of available values. Press YES when the value is correct.
- Press YES if the value of the OFF time of pulsing control is correct, press NO to scroll the list of available values. Press YES when the value is correct.

Figure 45. ON/OFF Intervals

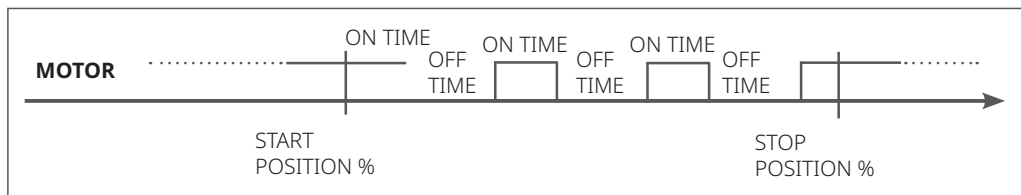

9.1.12 BUS (or FDI Control)

This routine is only available if a fieldbus interface card is present. The routine allows setting the most important parameters (node address, termination, etc.) necessary to connect the actuator to a fieldbus. If the F01-3000 was set to work with fieldbus, but the fieldbus card is not present, a Hardware alarm will be generated. Different interfaces are available to connect the F01-3000 to different types of fieldbus. If the bus interface is LonWorks, the routine "BUS" changes in "FDI control". See the specific manuals for instruction and setting of the above modules.

9.1.13 Miscellaneous

It includes different types of routines as "time and date", "factory settings", "lithium battery", "torque profile", etc. used only for special application or in particular conditions.

9.1.13.1 Time and Date

Time and date are used in maintenance functions to associate the time information to the memorized event (torque profile, alarm log, maintenance request, etc.). Time and date are entered at the time of manufacture, but they can be adjusted during commissioning or maintenance operations.

Configuration procedure

- Move the local selector to OFF and then simultaneously press OPEN and STOP. Select the language and enter the password according to the instructions (see "Entering the set-up mode"). When the message displayed is "SET-UP MODE OK?" press YES. Press YES to select actuator set-up menu, press NO to scroll the list of available routines and then press YES to select Miscellaneous.
- Press YES to enter the time and date routine.
- Press YES if the time is correct, press NO to change it.
- Enter hours, minutes and seconds. Press NO to scroll the list of available values, press YES to select.
- Press YES when the time is correct.
- Press YES if the date is correct, press NO to change.
- Enter day, month and year. Press NO to scroll the list of available values, press YES to select.
- Press YES if the date is correct.

9.1.13.2 Torque Limits

Torque limits are used as a reference for torque alarm and end of travel. With the option "standard", the torque limits are constant along the full stroke. The limits can be configured in the "stroke limits" or "torque set-up" routines and determine the torque alarm or end of travel situations. In the same particular application, it is useful to configure 3 different torque thresholds for each travelling direction, to limit separately the unseating, running and ending torque. To select this option pick "3-point limits" and then follow the torque set-up and stroke limits routines (see Figure 46).

Configuration procedure

- Move the local selector to OFF and then simultaneously press OPEN and STOP. Select the language and enter the password according to the instructions (see "Entering the set-up mode"). When the message displayed is "SET-UP MODE OK?" press YES. Press YES to select actuator set-up menu, press NO to scroll the list of available routines and then press YES to select Miscellaneous.
- Press NO and then NO to select "torque mode". Press YES if setting is correct, press NO to change. Press YES when the value is correct.
- Repeat stroke limits setting routine.

Figure 46. Torque Limit Setting

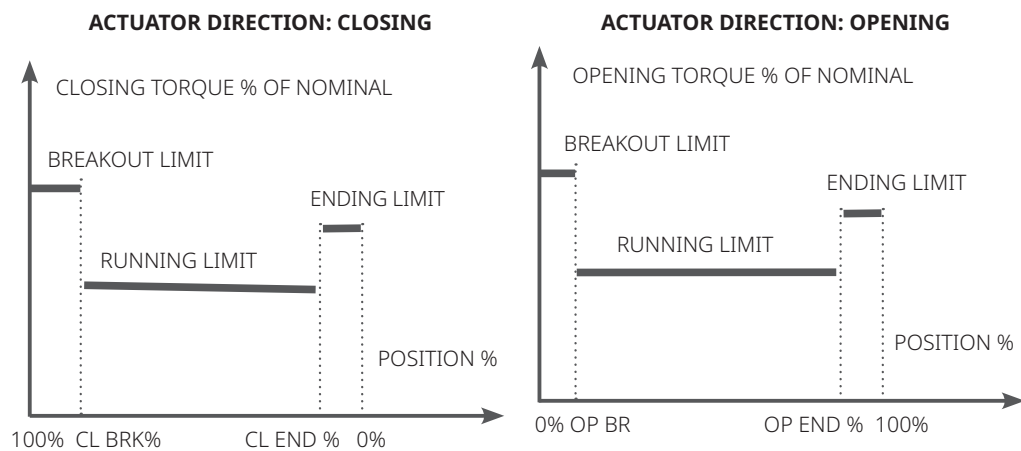

9.1.13.3 Lithium Battery

In the standard version, the actuator is provided with a lithium battery to keep visible the local position display, to back-up the RTC (real-time-clock) for diagnostic functions, to test the battery charge and to update the remote outputs (output relays status when set as "open limit" or "close limit" and 4 to 20 mA when externally supplied) in case of electrical power failure and manual override operations.

The program runs the functions relevant to the battery only if the appropriate flag "lithium battery" is configured with "present". If the battery is absent or if the above functions are not requested, the flag "lithium battery" should be configured with "absent".

Configuration procedure

- Move the local selector to OFF and then simultaneously press OPEN and STOP. Select the language and enter the password according to the instructions (see "Entering the set-up mode"). When the message displayed is "SET-UP MODE OK?" press YES. Press YES to select actuator set-up menu, press NO to scroll the list of available routines and then press YES to select Miscellaneous.
- Press No to scroll the list of routines and press YES to select lithium battery. Press YES if the setting is correct, press NO to change. Press YES when the value is correct.

9.1.13.4 Torque Bypass (%)

Since a high torque may be required to unseat certain valves, the torque bypass routine masks the torque alarm when an open or close command is received and the actuator is fully open or closed. The torque bypass is expressed in % of position and is configurable from 0 to 20%. For example, if a 10% bypass value is set, we may have:

- bypass active in Opening: from 0 to 10%
- bypass active in Closing: from 100 to 90%

To exclude torque bypass configure 0%.

Configuration procedure

- Move the local selector to OFF and then simultaneously press OPEN and STOP. Select the language and enter the password according to the instructions (see "Entering the set-up mode"). When the message displayed is "SET-UP MODE OK?" press YES. Press YES to select actuator set-up menu, press NO to scroll the list of available routines and then press YES to select Miscellaneous.
- Press No to scroll the list of routines and press YES to select torque bypass. Press YES if the setting is correct, press NO to change. Press YES when the value is correct.

9.1.13.5 Valve Jammed (Time)

The valve jammed time is used to monitor the following situations:

1. The time passed after receiving an open or close control is greater than the "valve jammed time", but the valve position variation is smaller than 0.5%. The motor is blocked, the command is cleared and the "valve jammed" alarm indication is generated.
2. The valve is moving, but during the travel the position valve variation is smaller than 0.5% in a time equal to "valve jammed time". The motor is blocked, the command is cleared and the "mid-travel alarm" indication is generated.

The valve jammed time is expressed in seconds and can be configured from 0 to 100 s. Configure "0" to exclude the routine.

Configuration procedure

- Move the local selector to OFF and then simultaneously press OPEN and STOP. Select the language and enter the password according to the instructions (see "Entering the set-up mode".) When the message displayed is "SET-UP MODE OK?" press YES. Press YES to select actuator set-up menu, press NO to scroll the list of available routines and then press YES to select Miscellaneous.
- Press No to scroll the list of routines and press YES to select valve jammed. Press YES if the setting is correct, press NO to change. Press YES when the value is correct.

9.2 Valve Data

The valve data allow identifying the valve and its function in the process. The valve manufacturer and the end user can enter the data. The following data can be entered:

- Tag name (maximum 28 characters)
- Serial number (maximum 28 characters)
- Manufacturer (maximum 28 characters)
- Break OP torque (maximum 28 characters)
- Break CL torque (maximum 28 characters)
- Maximum stem thrust (maximum 28 characters)
- Flange type (maximum 28 characters)

9.2.1 Sample Configuration Procedure

Tag name

- Move the local selector to OFF and then simultaneously press OPEN and STOP. Select the language and enter the password according to the instructions (see "Entering the set-up mode"). When the message displayed is "SET-UP MODE OK?" press YES.
- Press NO to scroll the list of available menus and then press YES to select valve data menu.
- Press NO to scroll the list of available routines and then press YES to select Tag name.
- Press YES if the 1st character of the string is correct. Press NO to scroll the list of available characters. Press YES to select the desired character.
- Enter up to 28 characters. Enter a blank character and "←" as end of string.

The configuration of all other valve data items is made in the same way, by selecting the relevant item from the list of available routines.

9.3 Maintenance

A large amount of data is stored in the actuator memory and is available for future analysis or to assist the operator in the maintenance program. The maintenance menu also includes the set password routine and the possibility to modify or start the maintenance functions.

The following data are available:

- new password
- clear alarm log
- torque profile reference
- torque curve reference
- clear recent data log
- configuration (backup/restore)
- maintenance date
- data logger
- PST reference (only if INTERLOCK = ADVANCED)
- PST cmd (only if INTERLOCK = ADVANCED)

9.3.1 Set Password

The actuator is supplied by Biffi with a default password ("0 0 0 0"). By the above routine, the end user can enter a different password consisting of 4 alphanumeric characters. After entering the new password, the old one ceases to be valid. Therefore, it is mandatory "NOT TO FORGET THE PASSWORD" after the default one has been modified. Forgetting the new password makes it impossible to enter the set-up menu and to configure the actuator.

Configuration procedure

- Move the local selector to OFF and then simultaneously press OPEN and STOP. Select the language and enter the password according to the instructions (see "Entering the set-up mode"). When the message displayed is "SET-UP MODE OK?" press YES. Press NO to scroll the list of available menus and then press YES to select Maintenance menu.
- Press NO to scroll the list of available routines and then press YES to select Set password. Press YES again to select Enter new password.
- Enter the new password one digit at a time. Press YES if the digit is correct, press NO to scroll the list of available characters and then press YES to select. Enter 4 digits. When the display shows the message "Password changed", the old password is no longer valid.

9.3.2 Clear Alarm Log

Clear Procedure

- Move the local selector to OFF and then simultaneously press OPEN and STOP. Select the language and enter the password according to the instructions (see "Entering the set-up mode"). When the message displayed is "SET-UP MODE OK?" press YES. Press NO to scroll the list of available menus and then press YES to select the Maintenance menu.
- Press NO to scroll the list of available routines and then press YES to select clear alarm log.
- Press YES to clear alarm log.

9.3.3 Set Torque Reference

The set torque profile reference routine allows to transfer the last torque profile to the reference profile registers. The old reference data are lost and the new ones are used as a new reference torque profile.

- Move the local selector to OFF and then simultaneously press OPEN and STOP. Select the language and enter the password according to the instructions (see "Entering the set-up mode"). When the message displayed is "SET-UP MODE OK?" press YES. Press NO to scroll the list of available menus and then press YES to select maintenance menu.
- Press NO to scroll the list of available routines and then press YES to select Set torque reference.
- Press YES to update the torque reference data.

9.3.4 Set Curve Reference

The “set curve reference” routine allows to select 1 off 100 opening and closing torque curves in the memory of the F01-3000 and to transfer them to the torque curve reference registers. The old reference data are lost and the new ones will be the new torque curves reference (see View Routines, Maintenance, Torque Curve, Section 10.4.3).

Configuration procedure

- Move the local selector to OFF and then simultaneously press OPEN and STOP. Select the language and then enter the password according to the instructions (see “Entering the set-up mode”). When the message displayed is “SET-UP MODE OK?”, press YES. Press NO to scroll the list of available menus and then press YES to select maintenance menu.
- Press NO to scroll the list of available routines and then press YES to select Set curve reference.
- Press NO to scroll the list and then press YES to select the desired curves (in opening and closing).
- Press YES to update the torque curve reference.

9.3.5 Clear Recent Data Log

The clear recent data log routine allows to clear the counters of the recent operation log. This command does not affect the content of the “general operation log”.

The date of the “clear recent data log” is memorized and can be viewed in the maintenance date routine of the view menu.

Configuration procedure

- Move the local selector to OFF and then simultaneously press OPEN and STOP. Select the language and enter the password according to the instructions (see “Entering the set-up mode”). When the message displayed is “SET-UP MODE OK?”, press YES. Press NO to scroll the list of available menus and press YES to select the maintenance menu.
- Press NO to scroll the list of available routines and then press YES to select clear recent data log.
- Press YES.
- Press YES to clear or press NO to exit.

9.3.6 Configuration (Backup/Restore)

This routine allows the user to save or restore a copy of the current actuator configuration. After completing the configuration operations and verifying that they are working properly, the Backup sub-routine creates a copy of the configuration in the actuator's permanent memory. The copy thus created can be used by means of the Restore sub-routine in the future to return to a known condition to cancel any subsequent changes.

Backup procedure

- Move the local selector to OFF and then simultaneously press OPEN and STOP. Select the language and enter the password according to the instructions (see "Entering the set-up mode"). When the message displayed is "SET-UP MODE OK?", press YES. Press NO to scroll through the list of available menus and press YES to select the "Configuration (Backup/Restore)" menu.
- Press NO to scroll through the list of available routines and then press YES to select "Backup".
- Press YES to confirm the operation or press NO to exit.
- At the end of the operation, the display shows the message "BACKUP DONE" for a few seconds.

Restore procedure

- Move the local selector to OFF and then simultaneously press OPEN and STOP. Select the language and enter the password according to the instructions (see "Entering the set-up mode"). When the message displayed is "SET-UP MODE OK?", press YES. Press NO to scroll through the list of available menus and press YES to select the "Configuration (Backup/Restore)" menu.
- Press NO to scroll through the list of available routines and then press YES to select "Restore".
- Press YES to confirm the operation or press NO to exit.
- At the end of the operation, the display shows the message "RESTORE DONE" for a few seconds.

9.3.7 Set PST Reference

This routine allows the user to select as reference a PST curve among the curves already stored.

Configuration procedure

- Move the local selector to OFF and then simultaneously press OPEN and STOP. Select the language and enter the password according to the instructions (see "Entering the set-up mode"). When the message displayed is "SET-UP MODE OK?", press YES. Press NO to scroll through the list of available menus and press YES to select the "PST reference" menu.
- Press NO to scroll through the list of available routines and then press YES to select "Sel. curve".
- Press NO to scroll through the list of the available curves from 1 to 16 considering that 16 is the index of the last curve, press YES to select the selected curve.
- At the end of the operation, the display shows the message "REFERENCE OK" for a few seconds.

9.3.8 PST Command

This routine allows the user to execute on the actuator a PST command.

Configuration procedure

- Move the local selector to OFF and then simultaneously press OPEN and STOP. Select the language and enter the password according to the instructions (see "Entering the set-up mode"). When the message displayed is "SET-UP MODE OK?", press YES. Press NO to scroll through the list of available menus and press YES to select the "PST cmd" menu.
- In the menu "New base line", select if the PST that is going to be executed is a reference curve: press NO to scroll through the list of available options "Enabled" or "Disabled" and press YES to confirm the selection.
- Press YES to confirm the PST execution and follow the instructions on the local display.

9.3.9 Set Maintenance Date

The maintenance date routine allows the following operations:

- to set the last maintenance date
- to set the next maintenance date
- to set the start-up date

Configuration procedure

- Move the local selector to OFF and then simultaneously press OPEN and STOP. Select the language and enter the password according to the instructions (see "Entering the set-up mode"). When the message displayed is "SET-UP MODE OK?", press YES. Press NO to scroll the list of available menus and then YES to select the maintenance menu.
- Press NO to scroll the list of available routines and press YES to select maintenance date.
- Press YES to set the last maintenance date. Press NO to skip to "next maintenance date".

Last maintenance date

- Press YES if the date is correct, press NO to change it.
- Enter day, month and year. Press NO to scroll the list of available values, press YES to select.
- Press YES if the date is correct.

Next maintenance date

- Press YES if the date is correct, press NO to change it.
- Enter day, month and year. Press NO to scroll the list of available values, press YES to select.
- Press YES if the date is correct.

Start-up date

- Press YES if the date is correct, press NO to change it.
- Enter day, month and year. Press NO to scroll the list of available values, press YES to select.
- Press YES if the date is correct.

9.3.10 Set Data Logger

The “data logger” routine allows to set the data logger parameters (see View Routines, Maintenance, Data Logger, Section 10.4.6). To start the data logger, the following data should be set:

Logger mode	recorder, event, off
Sampling time	from 1 to 3600 s (the sampling time is only used in recorder mode)
Memory mode	stop when memory is full, continuous (stop after overwriting the memory 5000 times (event) and 10000 times (recorder/T-recorder))
Start date	date when the logger starts
Start time	time when the logger starts

Configuration procedure

- Move the local selector to OFF and then simultaneously press OPEN and STOP. Select the language and then enter the password according to the instructions (see “Entering the set-up mode”). When the message displayed is “SET-UP MODE OK?”, press YES. Press NO to scroll the list of available menus and then press YES to select maintenance menu.
- Press NO to scroll the list of available routines and then press YES to select “data logger”.
- Press YES if the mode is correct. Press NO to scroll the list of modes and press YES to select the desired value.
- Press YES if the sampling time is correct. Press NO to scroll the list of times and press YES to select the desired value.
- Press YES if the memory mode is correct (stop when full or continuous). Press NO to change and press YES to select.
- Press YES if the start time is correct. Press NO to scroll the list and press YES to select the desired sampling times (hour, min, sec).
- Press YES if the start date is correct. Press NO to scroll the list and press YES to select the desired sampling times (day, month, year).
- Press YES to confirm the above settings.

9.4 Example of Set-Up Routine

9.4.1 Torque Set-Up

Figure 47. Torque Set-Up Menu

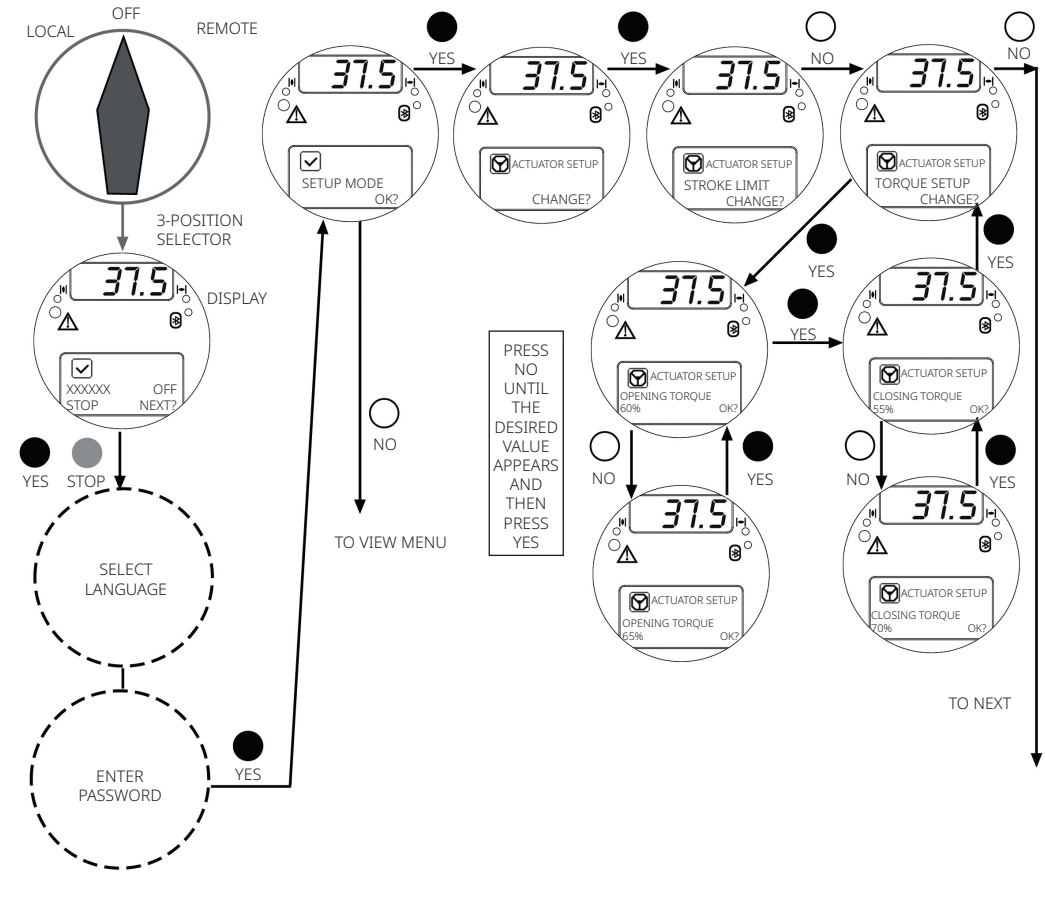

To exit from the SETUP menu, press YES and NO simultaneously or move the 3-position selector to LOCAL or REMOTE.

Section 10: View Routines

10.1 Actuator Set-Up

The above menu allows to view the present actuator configuration. No change can be made to the present data. The following data can be viewed (see Table 11).

Table 11. Actuator Set-Up Settings

Routine	Parameters
Stroke limits	Close direction (CW, CCW), close limit type (torque or position), open limit type (torque or position)
Torque set-up	Closing torque limit %, opening torque limit %
ESD control	ESD action, signal type, ESD priority
PST set-up	PST configuration. Available if INTERLOCK= ADVANCED
Remote controls	Control type
Local controls	Control type, color of LEDs
Output relays	Monitor relay conditions, ASi conditions, contact action
Positioner *	Dead band, motion inhibit time, polarity, %minimum, %maximum (%minimum and %maximum are present only if "position request R%" is from 4 to 20 mA input)
Fail-safe *	Action, delay
Out 4 to 20 mA *	Output signal (position or torque), polarity
Interlock	Signal type in OP, signal type in CL
2-speed timer	Close direction: status, start, stop, on time, off time Open direction: status, start, stop, on time, off time
Bus *	Node address, terminations, etc. depending on fieldbus type
Miscellaneous	Time and date, torque mode, lithium battery, torque bypass %, valve jammed time

NOTE:

The routines with * can only be viewed if the relevant electronic cards are present. If the bus interface is LonWorks, the "BUS" routine changes to "FDI control". Detailed descriptions of the above routines and their parameters can be found in Section 9.

View procedure

- Move the local selector to OFF and then simultaneously press OPEN and STOP. Select the language according to the instructions (see "Entering the view mode"). When the message displayed is "VIEW MODE OK?", press YES. Press YES to select the actuator set-up menu.
- Press NO to scroll the list of available routines and press YES to select.
- Press YES to answer at the prompt "view" or "next" and to see the data.

10.2 Nameplate

Use this menu to view the data identifying the actuator. The data are entered in-house and can only be changed by the manufacturer. The following data may be viewed:

- Serial number: maximum 28 characters, univocal identifier of the actuator by reference to Biffi acknowledgment.
- Actuator type: maximum 28 characters, describes the type of actuator with reference to Biffi catalog.
- Torque / Thrust: nominal torque or thrust of actuator.
- Actuator speed: nominal speed of actuator.
- Power supply: nominal voltage and frequency of actuator.
- Motor data: includes the following data relevant to the electrical motor:
 - Power type (3ph, 1ph, dc)
 - Power rating, maximum 99.9 kW
 - In, maximum 99.9 A
 - Is, maximum 99.9 A
 - Icc, maximum 999.9 A
 - Duty (S2/15 min, etc.)
 - Poles (2, 4, etc.)
 - Biffi name, maximum 28 characters
 - Gear ratio, maximum 1000
- Test date: date of the in-house functional test of actuator.
- Wiring diagram (WD): wiring diagram number, maximum 28 characters.
- Enclosure: type of enclosure (Ex d, etc.), maximum 28 characters.
- Certificate: number of certificate, maximum 28 characters.
- Lubricant: type of lubricant, maximum 28 characters.
- Revision: HW revision of base card, SW revision of H8 microprocessor, SW revision of PIC microprocessor.
- Torque sensor: data relevant to the relationship between motor torque and speed. This set of data also includes the factory torque limit setting, "Torque set CL" and "Torque set OP".

View procedure

- Move the local selector to OFF and then simultaneously press OPEN and STOP. Select the language according to the instructions (see "Entering the view mode"). When the message displayed is "VIEW MODE OK?" press YES. Press NO to scroll the list of available menus and press YES to select the nameplate menu.
- Press YES to answer the prompt "view" or "next" and see the data in the above list.

10.3 Valve Data

To identify the valve and its function in the process, the following data can be viewed:

- Tag name (maximum 28 characters)
- Serial number (maximum 28 characters)
- Manufacturer (maximum 28 characters)
- Break OP torque (maximum 28 characters)
- Break CL torque (maximum 28 characters)
- Maximum stem thrust (maximum 28 characters)
- Flange type (maximum 28 characters)

The data should be entered by the valve manufacturer or by the end user during set-up operations.

View procedure

- Move the local selector to OFF and then simultaneously press OPEN and STOP. Select the language according to the instructions (see "Entering the view mode"). When the message displayed is "VIEW MODE OK?" press YES. Press NO to scroll the list of available menus and press YES to select the valve data menu.
- Press YES to answer prompts "view" or "next" and see the data in the above list.

10.4 Maintenance

10.4.1 Alarm Log

The alarm log routine is used to view the list of the latest 5 alarms and 5 warnings and the data when they occurred. The "clear alarm log" routine of the set-up menu should be used to clear the list.

View procedure

- Move the local selector to OFF and then simultaneously press OPEN and STOP. Select the language according to the instructions (see "Entering the view mode"). When the message displayed is "VIEW MODE OK?" press YES. Press NO to scroll the list of available menus and press YES to select the Maintenance menu.
- Press YES to answer the prompt "Alarm log view?".
- Press YES to scroll the list of alarms ("Alarms view?").
- Press NO to move on to "Warnings view?" and then YES to scroll the list of warnings.

10.4.2 Torque Profile

The torque profile routine gives important information on the actuator working conditions in comparison with a previously memorized reference profile. It can give an indication of a change in the process conditions. Details are given of the reference and latest torque expressed in % of the nominal torque.

At the end of a full stroke in opening or closing, the F01-3000 stores the 3 maximum torque values in position intervals 0 to 10%, 10 to 90%, 90 to 100% in opening and the 3 maximum torque values in position intervals 100 to 90%, 90 to 10%, 10 to 0% in closing. Time and date of strokes are also saved. The above data are updated at the end of every full valve stroke and the previous ones are lost. Function "set torque reference", in the SET-UP MENU, Maintenance, (Section 9.3), allows to save the "torque profile" data in the "torque profile reference" with date and time. The "torque profile reference" will not be updated until a new "set torque reference" command is entered. The user can compare the last torque profile relevant to the last valve stroke with the torque profile reference saved before.

The following definitions will be used:

- Breakout: maximum torque % in position interval 0 to 10% in opening or 100 to 90% in closing = maximum % of torque to unseat the valve.
- Peak running: maximum torque % in position interval 10 to 90% in opening or 90 to 10% in closing = maximum % of torque when the valve runs from Breakout to Ending (maximum mid-travel).
- Ending: maximum torque % in position interval 90 to 100% in opening or 10 to 0% in closing = maximum % of torque to seat the valve.

The following data may be viewed:

Closing torque

- Breakout %
- Breakout reference %
- Peak run %
- Peak run reference %
- Ending %
- Ending reference %
- Date of the last stroke
- Date of reference (same of opening)

Opening torque

- Breakout %
- Breakout reference %
- Peak run %
- Peak run reference %
- Ending %
- Ending reference %
- Date of the last stroke
- Date of reference (same of closing)

View procedure

- Move the local selector to OFF and then simultaneously press OPEN and STOP. Select the language according to the instructions (see “Entering the view mode”). When the message displayed is “VIEW MODE OK?” press YES. Press NO to scroll the list of available menus and press YES to select the Maintenance menu.
- Press NO to scroll the list of routines and press YES to select torque profile.
- Press YES to scroll the list of values.

10.4.3 Torque Curve

The torque curve routine gives important information on the actuator working conditions in comparison with a previously memorized reference torque curve. It can be used to perform a detailed analysis of a change in the process conditions.

During a full valve stroke in opening or closing, the F01-3000 measures the torque values relevant to every 1% of position variation. At the end of the stroke, the collected 101 values (one torque value every 1% of position change) are saved in the F01-3000 memory together with the time and date of strokes, main voltage, motor temperature, temperature inside the electronics compartment and temperature inside the terminal board compartment. Up to 100 curves in opening and 100 curves in closing can be saved. When a new curve is available, the oldest one is cancelled and the new one is memorized. The above data are updated at the end of every full valve stroke. Data relevant to a partial stroke are discharged. Function “set curve reference” in the SET-UP MENU, Maintenance, Section 9.3, allows to save the full set of data relevant to 1 off 100 “torque curves” in the “torque curve reference”. The “torque curve reference” will not be updated until a new “set curve reference” command is entered.

The user can compare the last 100 torque curves in opening and closing relevant to the last 200 valve strokes with the torque curve reference saved before.

Table 12 shows the list of saved data for each opening or closing curve:

Table 12. Torque Curve Settings

Date	Date of the valve stroke
Time	Time of the valve stroke
Temperature	Temperature (°C) inside the electronics compartment during the valve stroke
Term temp	Temperature (°C) inside the terminal board compartment during the valve stroke
Motor temp	Temperature of the electrical motor (°C) during the valve stroke
Main voltage	Main voltage supply (V) during the valve stroke
Closing / Opening time	
Torque 0	Torque value in % of the nominal torque/thrust stated in the nameplate menu. In opening “Torque 0” corresponds to position 0% and in closing “Torque 0” corresponds to position 100%
Torque 100	Torque value in % of the nominal torque / thrust stated in the nameplate menu. In opening “Torque 100” corresponds to position 100% and in closing “Torque 100” corresponds to position 0%

The amount of data to be viewed is large and the local display can only visualize one datum at a time. To use this function, we suggest to utilize the features available with PDAs and PC through Bluetooth wireless connection. The figure below shows an example of graph available on PDA or PC screen, showing the reference opening torque curve and the latest opening torque curve.

View procedure

- Move the local selector to OFF and then simultaneously press OPEN and STOP. Select the language according to the instructions (see "Entering the view mode"). When the message displayed is "VIEW MODE OK?" press YES. Press NO to scroll the list of available menus and press YES to select the Maintenance menu.
- Press NO to scroll the list of routines and press YES to select torque curve.
- Press NO to scroll the list of available curves (from 1 to 5 and reference). The curve 1 is the latest and the curve 5 is the oldest. Press YES to select.
- Press YES to select the opening or closing curve. Press NO to exit.
- Press YES to scroll the list of values. Press NO to exit.

10.4.4 Operation Log

The operation log consists of different counters and routines that provide information to assist in the maintenance program. The data are grouped into 2 families: general and recent data. The general data log collects data from "test date" to "present date". The test date is set in house, can be viewed in the "nameplate" menu but cannot be changed. The recent data log collects data from the last "clear recent data log" date to "present date".

Command "clear recent data log" is available in the SET-UP MENU, Maintenance, Section 9.3. This command clears the content of the recent data log and resets the counters to 0. The old data are lost.

The main differences between "general" and "recent" data log are the following:

- The general data log gives information relevant to the full life of the actuator, starting from the manufacturing date.
- In the recent data log, the same data are collected starting from a date set by the user. The date may be viewed in the MAINTENANCE DATE paragraph.

Figure 48. Torque Log

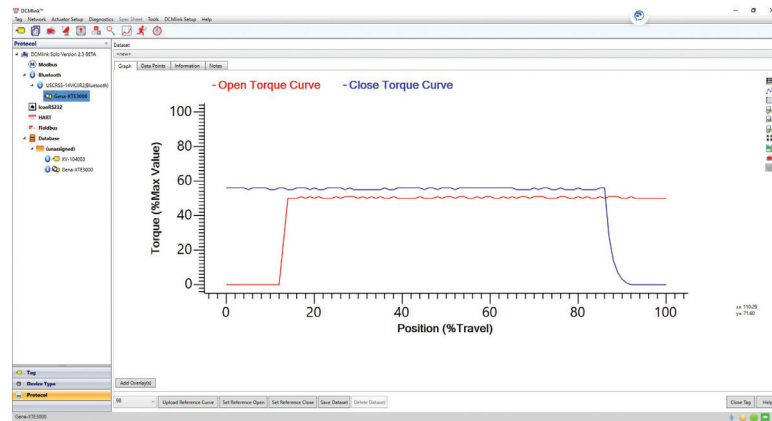

Table 13 shows list of data collected by the general and recent data log.

Table 13. Operation Log List

Routine	Parameters
Opening time	-
Closing time	-
Contactors cycles	Contactors cycles
Motor run time	Motor run time
No power time	No power time
Utilization rate	Utilization rate
Temperature minimum	Temperature minimum
Temperature maximum	Temperature maximum
Term temp minimum	Term temp minimum
Term temp maximum	Term temp maximum
Motor temp maximum	Motor temp maximum
Thermostat alarms	Thermostat alarms
Torque alarms	Torque alarms

View procedure

- Move the local selector to OFF and then simultaneously press OPEN and STOP. Select the language according to the instructions (see “Entering the view mode”). When the message displayed is “VIEW MODE OK?”, press YES. Press NO to scroll the list of available menus and press YES to select the Maintenance menu.
- Press NO to scroll the list of available routines and press YES to select operation log.
- Press YES to select general data or press NO to skip to recent data.
- Press YES to scroll the list of values.
- Press YES to view the recent data log or press NO to exit.
- Press YES to scroll the list of values.

Table 14. View Log List

General Data	
Opening time	This datum is only available in the general data log. It is updated at the end of every full valve stroke of the valve in opening direction. The data of the previous stroke are lost. It gives the time necessary to the valve to move from the close position to the open position, expressed in hours, minutes and seconds.
Closing time	This datum is only available in the general data log. It is updated at the end of every full valve stroke of the valve in closing direction. The data of the previous stroke are lost. It gives the time necessary to the valve to move from the open position to the close position, expressed in hours, minutes and seconds.
Contactors cycles	This number counts the cycles of contactors K1 and K2. The value indicated in the general data log is also used to generate the “maximum contactor cycles” warning when the maximum allowable number of cycles of the contactor is reached (see Section 12.10, Diagnostic Messages). If the main power is DC or single phase and in modulating actuators, the counters (general and recent) are hold to 0.
Motor run time	This number counts the hours with motor energized.
No power time	This number counts the hours without electrical power.
Utilization rate	This number % is incremented every 200 full strokes of the actuator. It reaches 100% after 20000 full strokes.
Temperature minimum	This is the lowest temperature value (in °C) measured inside the electronics compartment.
Temperature maximum	This is the highest temperature value (in °C) measured inside the electronics compartment.
Term temp minimum	This is the lowest temperature value (in °C) measured inside the terminal board enclosure.
Term temp maximum	This is the highest temperature value (in °C) measured inside the terminal board enclosure.
Motor temp maximum	This is the highest temperature value (in °C) measured in the electrical motor.
Thermostat alarms	This counts the number of alarms due to the high temperature of the electrical motor and to the tripping of the motor thermostat.
Torque alarms	This counts the number of alarms due to high torque in opening and closing.

10.4.5 Maintenance Date

The routine allows viewing the following dates:

- Last date
- Next date
- Start-up date
- Recent log date

See Table 15.

View procedure

- Move the local selector to OFF and then simultaneously press OPEN and STOP. Select the language according to the instructions (see “Entering the view mode”). When the message displayed is “VIEW MODE OK?”, press YES. Press NO to scroll the list of available menus and press YES to select the Maintenance menu.
- Press NO to scroll the list of available routines and press YES to select the maintenance date routine.
- Press YES to scroll the list of dates.

Table 15. Maintenance Date

Maintenance Date	Setting
Last date	This is the date of the last maintenance operation. The date should be updated by the user after all maintenance operations (see Section 9.3).
Next date	This is the date of the next scheduled actuator maintenance. When the date is reached, the F01-3000 generates a maintenance request warning. The date should be updated by the user after all maintenance operations (see Section 9.3).
Start-up date	This is the date of actuator start-up. During commissioning, the user should enter the start-up date (see Section 9.3).
Recent log date	This is updated after entering command “Clear recent data log” (see Section 9.3). This command clears the “recent data log” counters. The content of “recent log” is updated starting from “recent log date”.

10.4.6 Data Logger

The “data logger” routine allows to collect different types of data useful in maintenance or in diagnostic programs. Since the amount of collected data is very large, the data logger can only be viewed by means of a PDA or PC. The data can be uploaded from F01-3000 to PDA or PC by the Bluetooth wireless connection.

The local display only allows to view the value of the configured parameters (see also SET-UP Routines, Maintenance, Set Data Logger, Section 9.3.10). The following data can be viewed on the local display:

- Logger mode
- Sampling time
- Memory mode
- Date
- Time

Data logger modes:

- OFF: the data logger is not active.
- RECORDER mode: the F01-3000 measures and memorizes the following 3 data:
 - Main voltage supply (V)
 - Motor temperature (°C)
 - Temperature inside the compartment of electronics (°C)
- T-RECORDER mode: the F01-3000 measures and memorizes the following 3 data:
 - Torque in OP/CL
 - Motor temperature (°C)
 - Voltage

In RECORDER and T-RECORDER mode, the SAMPLING TIME fixes the time interval among two sets of measures. Up to 256 sets of measures (equivalent to 256x4 samples) can be memorized. The sampling time can be configured from 1 to 3600 s. As the memory is full, the recorder stops recording or overwrites the previous data according to the selected MEMORY MODE (“stop when full” or “continuous”). If “continuous” was selected, as a new set of measures is achieved, the oldest one is cancelled and the new one becomes the latest. Up to 10000 cycles of full memory overwriting are done, then the recorder stops. In T-RECORDER mode, the recording operation is also stopped in case of OVER-TORQUE ALARM, in opening or in closing. This additional feature allows to maintain in the memory the last 256 samples and see the trend of torque, motor temperature and main voltage before the alarm. A new start of T-RECORDER clears the data stored in the memory. By a PDA or PC, the recorded data can be viewed by a graph where time is on the X axis and the measured data on the Y axis.

Figure 49 shows a graph with sampling time 2 s in RECORDER mode.

Figure 49. Recorder Mode

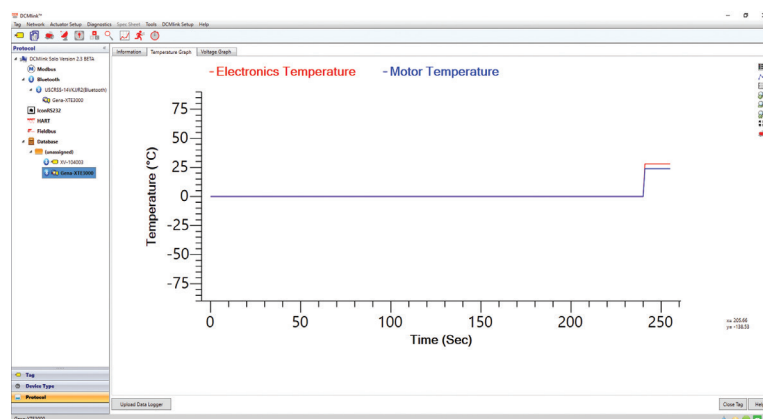
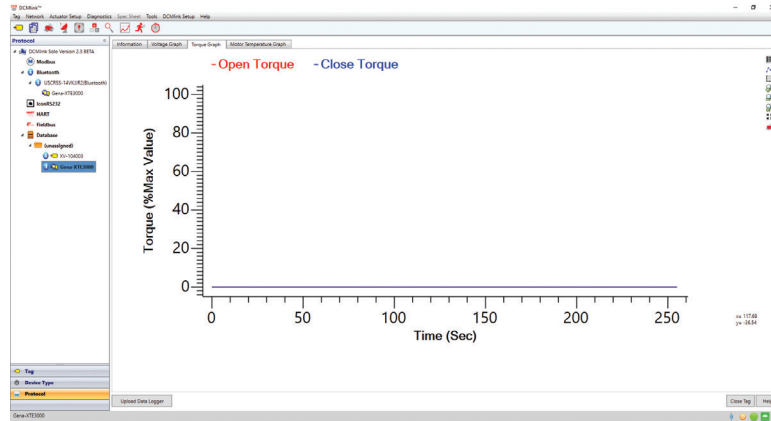

Figure 50 shows a graph with sampling time 1 s in T-RECORDER mode.

Figure 50. T-Recorder Mode



T-logger stops recording if a torque alarm is triggered. The last 256 samples remain in the actuator memory until a new start of the logger is initiated.

- **EVENT mode:** the F01-3000 detects the type of received command (OPEN or CLOSE), the source of the command (local controls, remote controls, bus, etc.) and date and time of command. Up to 128 EVENTS can be memorized. As the memory is full, the logger stops to memorize events or overwrites the previous data according to the selected MEMORY MODE ("stop when full" or "continuous"). If "continuous" was selected, as a new event is achieved, the oldest one is cancelled and the new one becomes the latest. Up to 50 cycles of full memory overwriting is done, then the logger stops. The START DATE and START TIME fix date and time to start recording operation. By a PDA or PC, the collected data can be viewed by a graph or event table. Parameter "sampling time" is not used.

Figure 51 shows an example of report in EVENT mode.

Figure 51. Event Mode

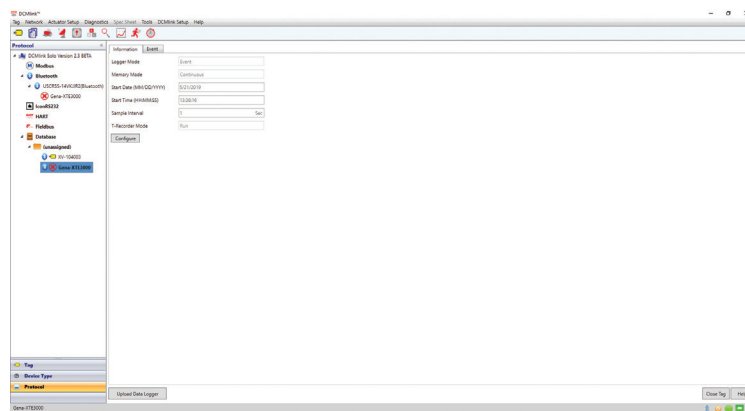

View procedure

- Move the local selector to OFF and then simultaneously press OPEN and STOP. Select the language according to the instructions (see “Entering the view mode”). When the message displayed is “VIEW MODE OK?”, press YES. Press NO to scroll the list of available menus and press YES to select maintenance menu.
- Press NO to scroll the list of routines and press YES to select data logger.
- Press YES to view the MODE, the SAMPLING time, the MEMORY mode, the start DATE and the start TIME.
- Press YES to return data logger. Press NO to exit.

10.5 Example of View Routine

10.5.1 View Torque Set-Up

Figure 52. Torque Set-Up Menu

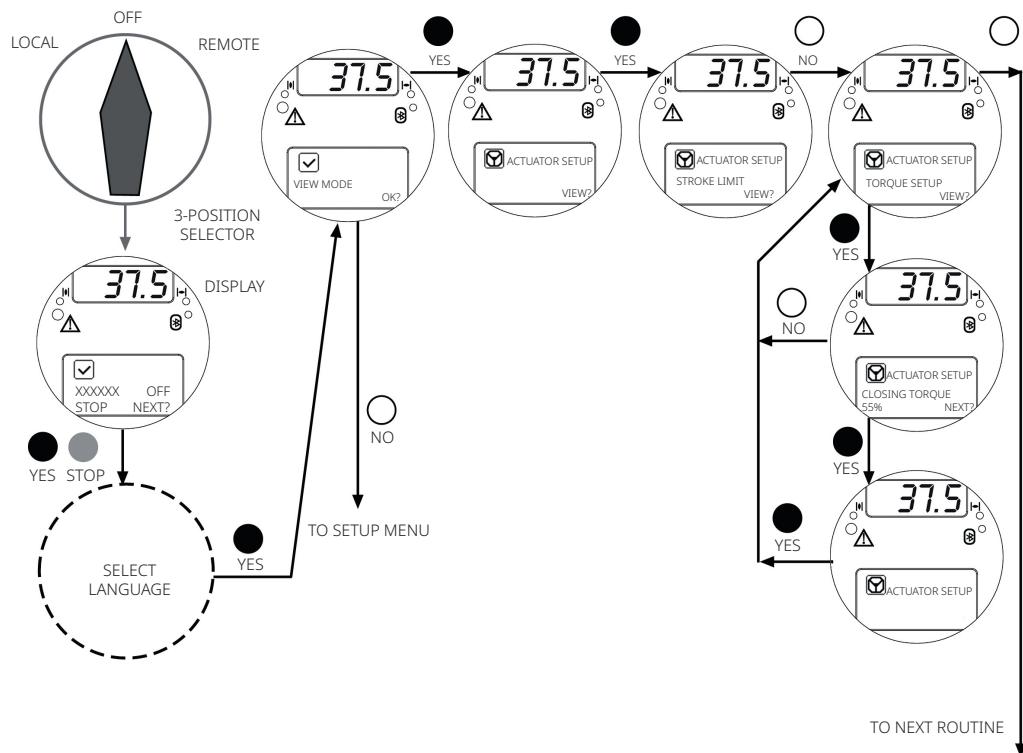

To exit from VIEW menu, press YES and NO simultaneously or move the 3-position selector to LOCAL or REMOTE.

Section 11: Maintenance

11.1 Standard Maintenance

Approximately every 2 years:

Under normal operating conditions, the F01-3000 is maintenance-free: no actuator maintenance is formally required, even though visual inspection for oil leakage or external visible damages is recommended every two years. When conditions are severe (frequent operation or high temperatures), inspect the oil level and oil quality more often. Replace all seals that permit oil leakage or water ingress.

NOTICE

Before starting any maintenance operation, make sure that the mains and all other service voltage connected to terminal board are switched-off.

⚠ WARNING

Installation, configuration, commissioning, maintenance and repairs must be performed by approved and qualified personnel only.

⚠ WARNING

Before performing service or maintenance operations (unless otherwise indicated), ensure that power is turned off to the unit to avoid injury and/or damage to equipment.

⚠ WARNING

The actuator is non-intrusive. The control compartment was sealed in dry and clean conditions and contains no site serviceable components. Do not open it unless absolutely necessary. Unauthorized access will invalidate the warranty.

⚠ CAUTION

Using a fastener other than the approved type may result in damage to the actuator or valve.

The following checks will assure optimum performance and can be considered as good practice in preventive and/or predictive maintenance:

- External visual inspection and general health check.
- Electrical enclosures: Check the external parts for possible damage and replace them immediately if necessary. If the window glass is broken, the complete cover must be replaced (see Section 13, Parts List and Drawings for individual item numbers).
- Electrical enclosures: perform an internal check of the cable glands and tightness of cable terminals and replace the cover O-ring.
- Make sure that there are no oil leaks from the actuator housing. Check the oil level; it should be approximately 20 mm from the fill plug. Top-up the oil volume if needed (see Section 4, Lubrication).
- Lubricate the internal components of the coupling block (if present) via the spherical head lubricator using suggested greases (see Section 4, Lubrication).
- If the stem is external, check that the valve stem is clean and lubricated. If not, clean and lubricate it in order to prevent damage to the threaded bush.
- Check that all nuts and bolts securing the actuator to the valve are tight. If necessary, retighten them with a torque wrench (for tightening torque values see, Section 3.4, Actuator Mounting).
- For actuators provided with lithium batteries, make sure that the display is still visible when the power is off and that there is no "Battery low" warning message. If the "Battery low" warning appears, replace the battery (see Section 11.3, Lithium Battery Change). Always replace batteries if the actuator has been subjected to long periods without power (see Section 12, Troubleshooting).
- Manual override operation check (if valve operation allows).
- Check local and remote electrical commands (if valve operation allows).
- Full Stroke test (FST) or Partial Stroke Test (PST) (if valve operation allows), torque vs. position diagram report (via AManager, if Bluetooth or a serial cable connection is available).
- Download .icon file (via AManager, if Bluetooth or a serial cable connection is available).
- Identification of recommended spare parts based on inspection results.
- Identification of next routine inspection date.
- Identification of maintenance needs during next planned plant outage/shut down.
- Final report, including .icon file.
- Repaint all areas where paint is missing. In chemically aggressive or saline environments, remove rust from surfaces and protect the unit with a rust preventative.
- For severe applications or if actuator operation is infrequent, more frequent maintenance checks are recommended.

11.2 Special Maintenance

In case of actuator failure, please refer to Section 12, Troubleshooting for possible causes. Spare parts can be required to Biffi: please refer to the individual item number shown in Section 13, Parts List and Drawings.

NOTICE

Special maintenance is also recommended when, during operations, the actuator generates an excessive noise.

11.3 Lithium Battery Change

Figure 53. Open Terminal Cover

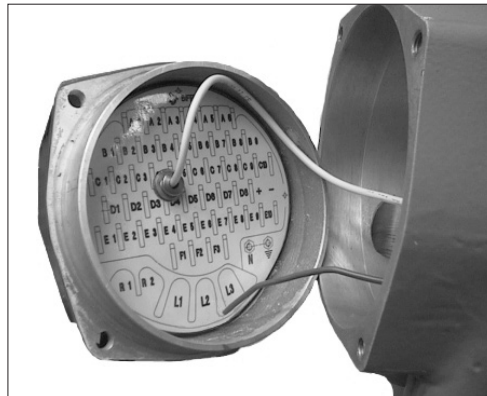

- Isolate the main supply to the actuator and all other control voltages.
- Open the terminal boards cover.
- Disconnect two wires (+) (-) from the main board.
- Bring the cover to a safe area. When in a safe area:
 - Remove the label.

Figure 54. Remove the Terminal Indication Label



Figure 55. Open the Battery Enclosure



Figure 56. Remove the Battery Cover

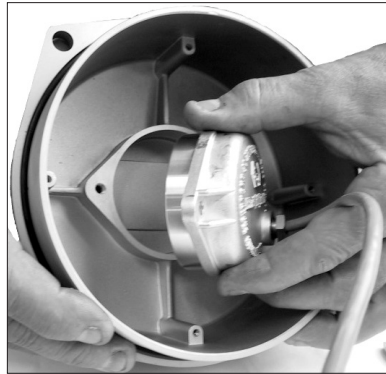

Figure 57. Loosen the Lock Nut

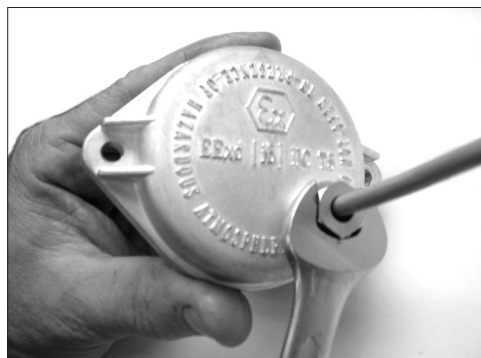

Figure 58. Detach Sealing Bushing

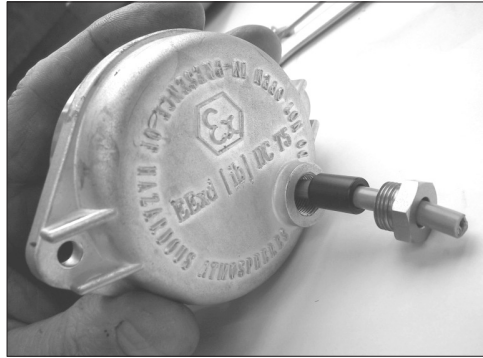
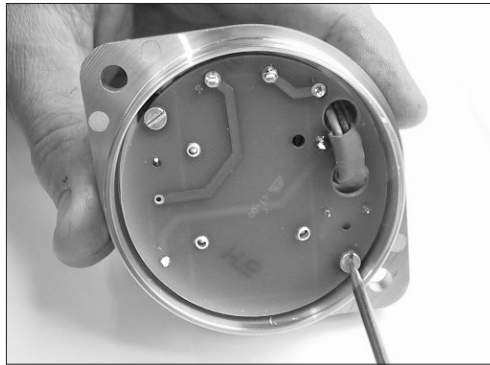

Figure 59. Detach Battery Board



-
- Replace the battery.

Figure 60. Access to the Battery



Figure 61. Remove the Battery



Figure 62. Replace with New Battery



⚠ WARNING

If the actuator is located in a hazardous area, a “hot work” permit must be obtained unless the actuator can be moved to a non-hazardous area.

NOTICE

The new battery must be the same type as the one provided: Lithium – SAFT LS 9 V.

NOTICE

To check the battery status, press the STOP button for at least 3 s. In any event, the battery status is automatically checked at least once a day. The expected battery life is up to 5 years but this can vary depending on frequency of usage and environmental conditions. Battery life may be reduced at high and low temperatures.

Section 12: Troubleshooting

The F01-3000 actuator has passed the functional test performed by Biffi Quality Assurance personnel.

WARNING

The actuator is non-intrusive. The control compartment was sealed in dry and clean conditions and contains no site serviceable components. Do not open it unless absolutely necessary. Unauthorized access will invalidate the warranty.

WARNING

Installation, configuration, commissioning, maintenance and repairs must be performed by approved and qualified personnel only.

WARNING

Before performing service or maintenance operations (unless otherwise indicated), ensure that power is turned off to the unit to avoid injury and/or damage to equipment.

If the actuator does not work before troubleshooting, make sure that:

- The numeric display indicates xx %
- The local selector is not in OFF
- The main supply voltage is the same as stated in the nameplate menu
- You move the local selector to OFF and check that the alphanumeric display shows one of the following messages:
 - “normal, off, stop”
 - “alarm, off, stop”
 - “warning, off, stop”
 - “ESD ON off”
 - “INT off”

If the above checks are satisfactory, try to locate the fault using the diagnostic facilities.

12.1 The Electronics Do Not Switch on When Powered

- Check that the value of the main voltage on terminals L1, L2, L3 is correct.
- Remove the cover of the compartment where the electronic cards are located.
- Check the fuse mounted on the power card. Replace it if burnt.
- If the fuse is OK, check the wires between terminals L1, L2, L3 and connector M1 of the power card. If it is correct, replace the power card.

12.2 DC Output Voltage Not Available at the Terminals

- Switch the main power supply off and disconnect all wires from terminals B1 to B2 and C1.
- Switch the main power supply on and check if the voltage on the terminals B1 to B2 and C1 is between 23 and 27 V DC.
- If the voltage is correct, check the external wiring and the electrical load. It should not exceed 4 W.
 - If the voltage is not correct, replace the power card.

Figure 63. Power Card and Terminals

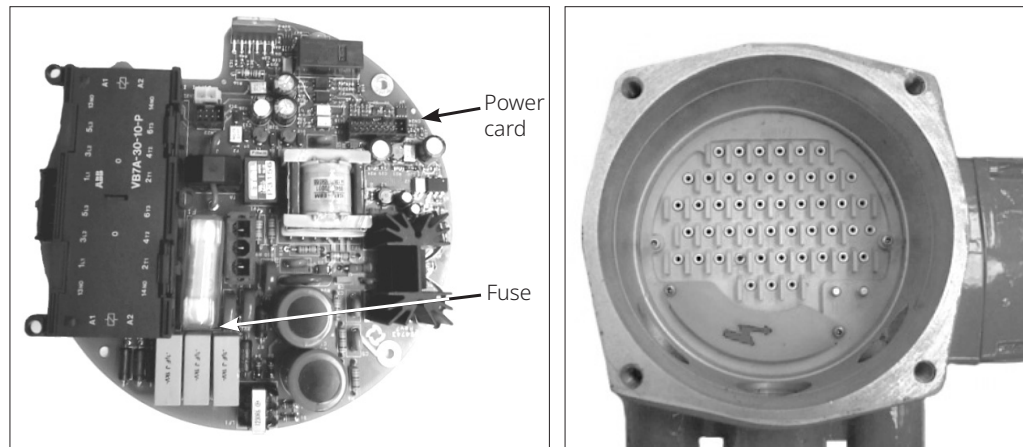

12.3 The Actuator Does Not Work from Remote Controls

- Move the 3-position selector to LOCAL and check that the actuator works from local controls.
- Move the local selector to REMOTE. If the ESD signal is active, the alphanumeric display indicates "ESD On". Check the signal on terminals C3 and C4 and adjust the ESD configuration.
- Check that:
 - the wiring to terminals B1 to B2 and C1 is correct
 - there is no short-circuit between wires
 - the electrical load does not exceed 4 W
 - the value is in the range 20 to 120 V AC 50/60 Hz or 20 to 125 V DC, if external voltage supply is used.

12.4 The Motor is Very Hot and Does Not Start

- Check that no alarm other than motor overheating is present.
- Wait until the motor cools down and the normally closed contact of the thermal switch automatically resets before trying to operate the actuator again.
- Check that the number of operations per hour and their duration is suitable for the actuator service (see the nameplate menu).
- Check that the valve operating torque is within the range of the unit's designed operating torque.
- Always check the causes of abnormal operation.

12.5 The Motor Runs But the Actuator Does Not Move the Valve

In case the local display does not change, the valve position indicators:

- Rotate the handwheel a few degrees to remove all possible sticking between the handwheel and the drive sleeve.

In case the local display changes, the valve position indicators:

- Verify the stem nut correctly fits in the actuator base.
- Verify the stem nut has sufficient engagement with the valve stem.
- Verify the key correctly fits in bore/keyways applications.
- Check that the valve works in manual operation.

12.6 The Valve Does Not Seat Correctly

- If the valve is stopped by the torque limit in closing, increase the actuator output torque limit.
- If the valve is stopped by the position limit in closing, check that the valve reaches its seat position, then readjust the setting of the position limit.
- The internal trim of the valve may be damaged.

12.7 Excessive Torque for Valve Operation

- Clean, lubricate and check the valve stem.
- Valve packing too tight: loosen the gland bolt nuts.
- Coupling: ensure there are no axial forces on the valve stem by leaving an adequate axial clearance between the stem and the drive bush. Also check that all transmission shafts, universal joints or bulkhead passages have sufficient lubrication and check that the transmission shafts are not bent.
- Check that the internal valve trim or the reducer gears are well lubricated and not damaged.
- Check the alphanumeric display for diagnostic messages and proceed with the suitable corrective actions as described in Section 12.10, Diagnostic Messages.

12.8 The Actuator Does Not Stop in Fully Open or Fully Closed Position

- Check that the actual open and close positions of the valve respectively correspond to 100% and 0% on the actuator display.
- Make sure that the torque and travel limits are correctly set (see Section 9.1, Set-Up Routines - Actuator Set-Up).

12.9 The Numeric Position Display Indicates "E01"

It is necessary to recalibrate the stroke limits (see Section 9.1, Set-Up Routines - Actuator Set-Up).

12.10 Diagnostic Messages

The alarm and warning lists contain the alarms and warnings momentarily present.

Warning is the condition that occurs when a variable reaches a critical value and/or when a maintenance action is required but all actuator functions are still available. The flashing of the alarm/warning LED indicates a warning condition.

Alarm is the condition that occurs when a variable is outside the acceptable range and some actuator function is not available. If the alarm/warning LED is on, there is an alarm condition. When the fault condition disappears, the corresponding alarm or warning also disappears from the list.

A reset routine is provided to clear the types of alarms and warnings that are memorized (over-torque, jammed valve, etc.).

View procedure

- Move the 3-position selector to either OFF or REMOTE, then press NO to scroll the list of available variables.
- Press YES when the display shows message "ALARMS view?" Press YES to scroll the list of alarms.
- Press NO when the display shows message "ALARMS view?"
- Press YES when the display shows message "WARNINGS view?" Press YES to scroll the list of warnings.
- Press YES to reset the alarms or warnings with memory.

Figure 64. Diagnostic Menu

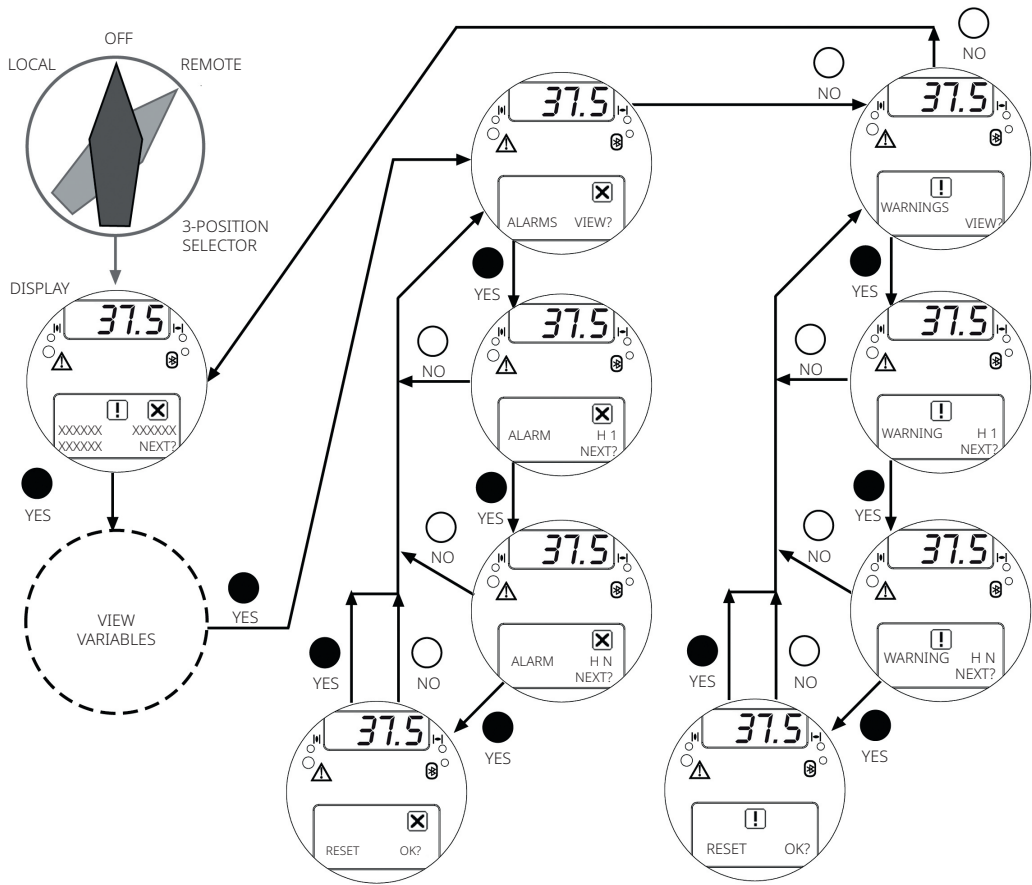

Table 16. Alarm Table

Display Message	Condition for Alarm	Action	Available Controls			Alarm Reset
			Local	Remote	ESD	
High torque in closing	Measured torque greater than the relevant value configured in torque set-up or stroke limits routine	Operate the actuator in open direction. Check the torque needed to operate the valve	Only open	Only open	Configuration dependent	Close control
High torque in opening	Measured torque greater than the relevant value configured in torque set-up or stroke limits routine	Operate the actuator in close direction. Check the torque needed to operate the valve	Only close	Only close	Configuration dependent	Open control
Jammed valve in closing	No position change after receiving a CLOSE control and motor speed is 0 RPM	Check status of actuator and valve mechanical parts	Only open	Only open	Only open	Open control
Jammed valve in opening	No position change after receiving an OPEN control and motor speed is 0 RPM	Check status of actuator and valve mechanical parts	Only close	Only close	Only close	Close control
Motor thermostat	Motor thermostat open for high temperature in the motor windings	Wait until the motor cools down	Not available	Not available	Configuration dependent	When thermostat close
Internal temperature	Temperature inside the actuator enclosure higher than 90 °C or lower than -40 °C	Ambient temperature too high or too low. Verify insulation among actuator and heat source	Not available	Not available	Not available	Control temperature <90 or >-40 °C
Position sensor	Value of the actuator position not valid	Replace position sensor or re-calibrate both stroke limits	Not available	Not available	Not available	Position signal correct
Speed sensor	Measure of motor speed not valid	Replace speed sensor	Not available	Not available	Not available	Speed signal correct
Mid travel alarm in OP	The valve does not move in presence of an open control and motor speed is 0 RPM	Check status of actuator and valve mechanical parts. Recalibrate both stroke limits.	Only close	Only close	Only close	Close control
Mid travel alarm in CL	The valve does not move in presence of a close control and motor speed is 0 RPM	Check status of actuator and valve mechanical parts. Recalibrate both stroke limits.	Only open	Only open	Only open	Open control
Main voltage	Main voltage lower than -20% or higher than +20% of the value stated in the nameplate menu or wrong frequency	Check main voltage supply and frequency on terminals L1, L2, L3. Check that wires section is correct	Not available	Not available	Not available	Main voltage correct
K1 contactor	The test routine reports a failure of K1 (coil or auxiliary contact)	Check the contactor	Opposite direction	Opposite direction	Not available if esd use k1 contactor	Control in opposite direction
K2 contactor	The test routine reports a failure of K2 (coil or auxiliary contact)	Check the contactor	Opposite direction	Opposite direction	Not available if esd use k2 contactor	Control in opposite direction
Configuration error	The checksum of the EEPROM memory that contains the configuration data is wrong	Re-configure all parameters	Not available	Not available	Not available	Memory OK

Table 16. Alarm Table (continued)

Display Message	Condition for Alarm	Action	Available Controls			Alarm Reset
			Local	Remote	ESD	
Configuration error	The checksum of the EEPROM memory that contains the configuration data is wrong	Reconfigure all parameters	Not available	Not available	Not available	Memory OK
HW error	The diagnostic program detects some malfunction in the electronics controlling the actuator	The circuit is damaged. Change control card.	Not available	Not available	Not available	HW OK
Low lithium battery	The voltage of the lithium battery is too low (only detected if the lithium battery is present and the relevant parameter of the miscellaneous routine is set to "present")	Change lithium battery	Available with main voltage	Available with main voltage	Available with main voltage	Lithium battery OK
Lost phase	The alarm appears only with 3-phase main supply. The alarm is generated in case of fault of one of the phases that supply the actuator transformer	Check main power supply on terminals L1, L2, L3	Not available	Not available	Not available	Phase OK

Table 17. Warning Table

Display Message	Condition for Alarm	Action	Available Controls			Alarm Reset
			Local	Remote	ESD	
High torque in OP (near maximum)	Measured torque 10% lower than the relevant value configured in torque set-up or stroke limits routines	Check the torque necessary to move the valve	Available	Available	Available	Close control
High torque in CL (near maximum)	Measured torque 10% lower than the relevant value configured in torque set-up or stroke limits routines	Check the torque necessary to move the valve	Available	Available	Available	Open control
Internal temp. (near limits)	Temperature inside the actuator enclosure higher than 80°C or lower than -35 °C	Find the heat source and insulate the actuator	Available	Available	Available	Control temperature >-35 and <80 °C
Main voltage (near limits)	Value of the main voltage out of the correct range (-15% or +10% of the value stated in the nameplate menu) or wrong frequency	Check section of wires and values of voltage and frequency	Available	Available	Available	Main voltage correct
Contacting cycles (maximum)	Maximum number of contactor cycles reached	Change contactor and reset operation log	Available	Available	Available	Clear recent data log
Maintenance request	Date of the next maintenance reached	Perform maintenance and set next maintenance date	Available	Available	Available	Change date
Motor current	Motor current greater or lower than limits	Check electrical motor	Available	Available	Available	Current OK
Wrong stroke limits	The routine that monitors the stroke limits detects a wrong end of travel condition	Recalibrate both stroke limits	Available	Available	Available	Recalibrate both stroke limits

Section 13: Parts List and Drawings

13.1 Introduction

This chapter includes the drawings and parts list of each component and subassembly of F01-3000 actuators.

CAUTION

Using a fastener other than the approved type may result in damage to the actuator or valve.

NOTICE

- When ordering spare parts, please indicate the serial number embossed on the actuator nameplate.
- When ordering spare parts, please refer to the marked part list items on the attached drawings.
- Recommended spares are marked with this sign * on parts list.

Figure 65. F01-3000

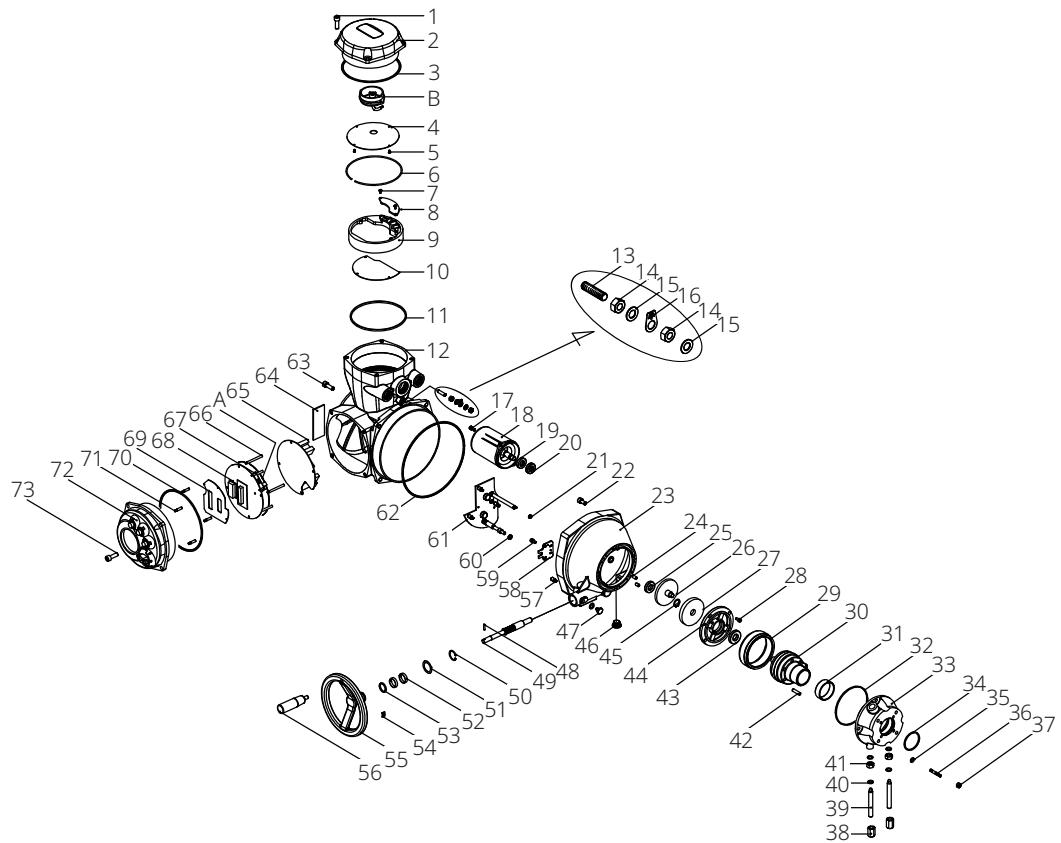

Table 18. Parts List

Item	Quantity	Description	Item	Quantity	Description	Item	Quantity	Description
1	4	Screw	29	1	Worm wheel	57	4	Column
2	1	Terminal board cover	30	1	Planicentric assembly	58	1	Torque plate
3	1	* O-ring	31	1	Guide bush	59	2	Screw
4	1	Terminals label	32	1	* O-ring	60	1	* O-ring
5	4	Screw	33	1	Thrust block	61	1	Torque/Position assembly
6	1	Circlip	34	1	* O-ring	62	1	* O-ring
7	2	Screw	35	4	Washer	63	4	Screw
8	1	Power terminals cover	36	4	Stud bolt	64	1	Data plate
9	1	Terminal board	37	4	Nut	65	1	Power card
10	1	I/O card	38	2	Mechanical stops nut	66	4	Column
11	1	* O-ring	39	2	Mechanical stops	67	1	Potentiometer card
12	1	Cover housing	40	2	Seal washer	68	1	Processor card
13	1	Earth stud	41	2	Nut	69	1	Display plate
14	2	Earth stud nut	42	1	Pin	70	1	* O-ring
15	2	Washer	43	1	Bearing	71	4	Column
16	1	Earth stud indication plate	44	1	Support flange	72	1	Local interface assembly
17	2	Screw	45	1	Circlip	73	4	Screw
18	1	Electric motor	46	2	Oil plug	Optional		
19	1	* Seal ring	47	1	Handwheel stop screw	A	1	Bus interface card
20	1	Bearing	48	1	Pin	B	1	Battery group
21	1	* O-ring	49	1	Worm gear assembly			
22	1	Screw	50	1	Circlip			
23	1	Housing	51	1	Handwheel ring			
24	2	* Pin	52	1	Handwheel slide ring			
25	1	Bearing	53*	1	* O-ring			
26	1	Double wheel 1 st stage	54	1	Handwheel retaining ring			
27	1	Wheel 2 nd stage	55	1	Handwheel			
28	3	Screw	56	1	Hand grip			

NOTE:

* Recommended spare parts

Figure 66. F01-3000 - Planicentric Assembly

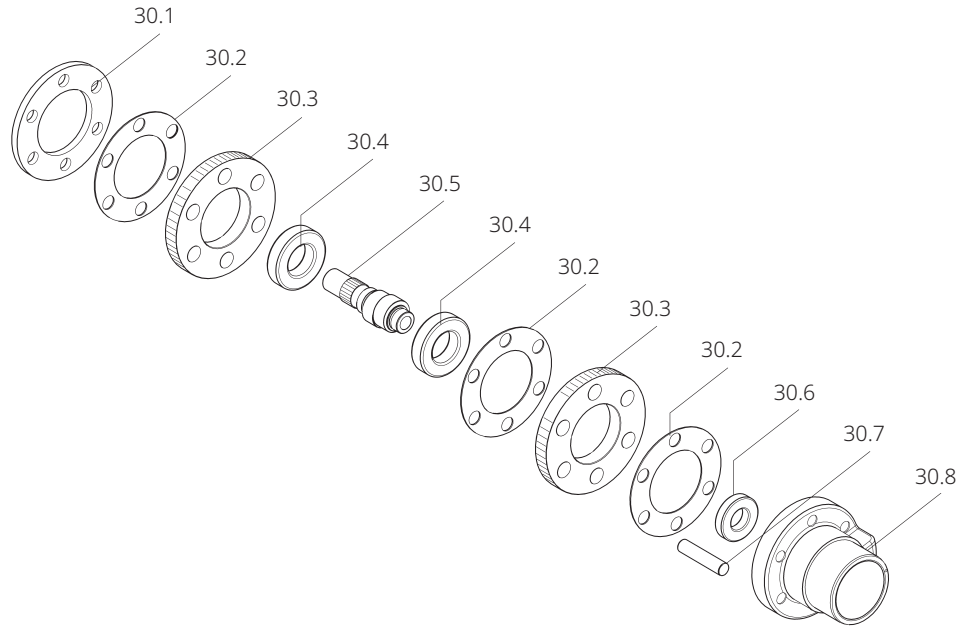

Table 19. Parts List

Item	Quantity	Description
30.1	1	Pin guide ring
30.2	3	Spacer ring
30.3	2	Eccentric wheel
30.4	2	Bearing
30.5	1	Double eccentric shaft
30.6	1	Bearing
30.7	6	Pin
30.8	1	Splined bush

Figure 67. F01-3000 - Worm Gear Assembly

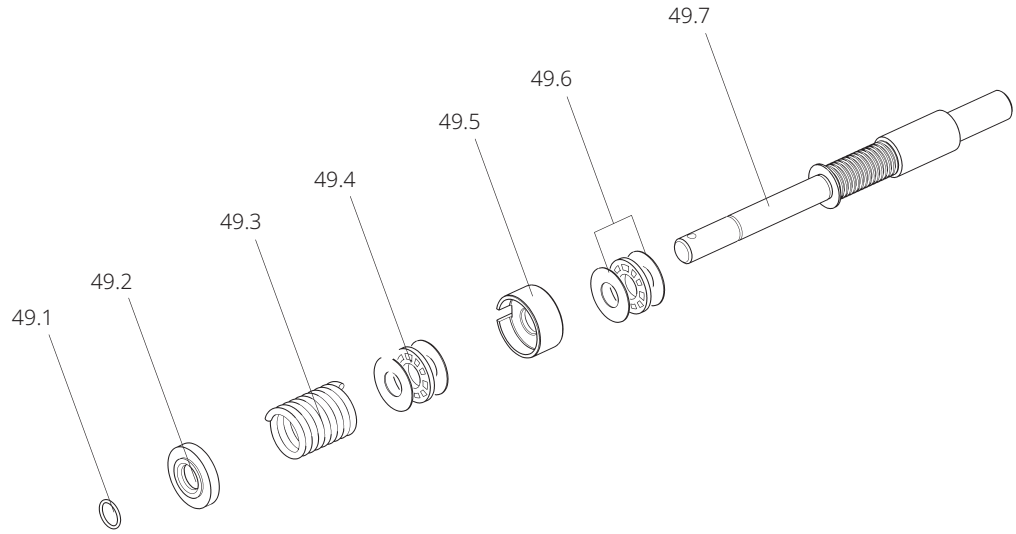

Table 20. Parts List

Item	Quantity	Description
49.1	1	Stop ring
49.2	1	Spring support
49.3	1	Spring
49.4	2	Axial bearing
49.5	1	Thrust bearing support
49.6	4	Axial bearing shoulder
49.7	1	Worm gear

Figure 68. F01-3000 - Torque/Position Assembly

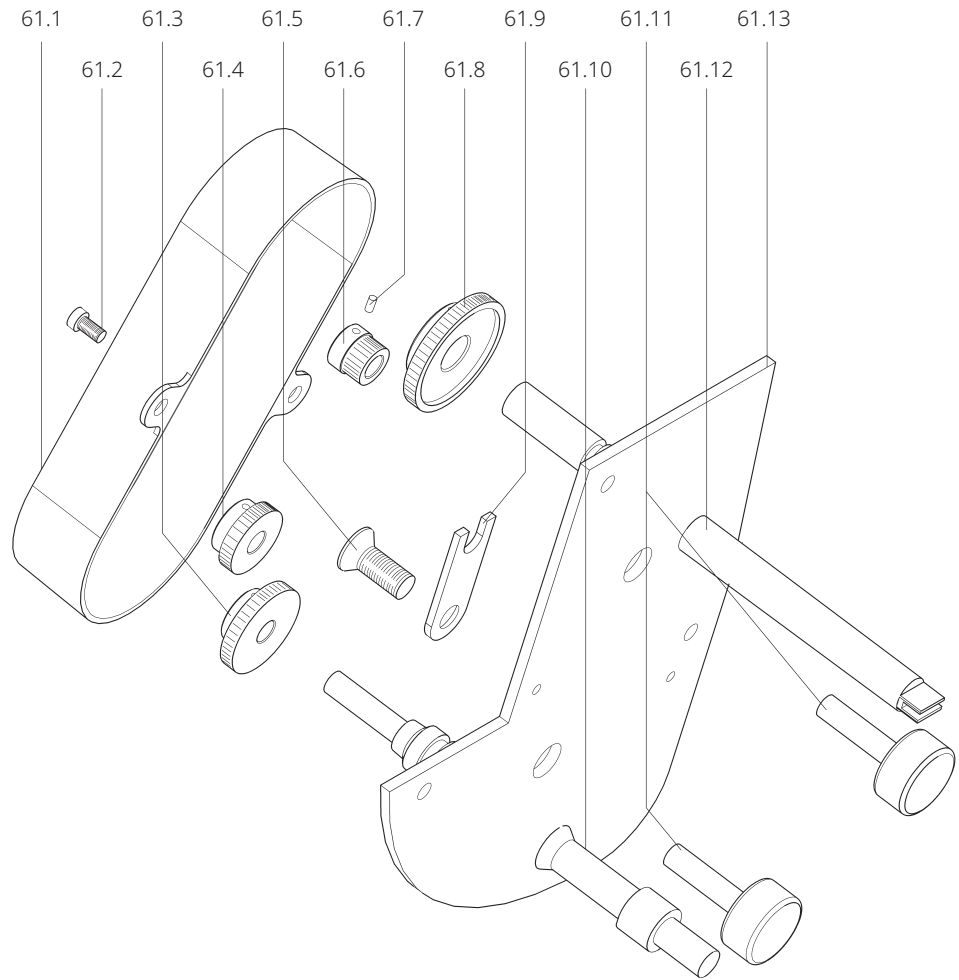

Table 21. Parts List

Item	Quantity	Description
61.1	1	Gear cover
61.2	5	Screw
61.3	1	Gear
61.4	1	Gear
61.5	1	Screw
61.6	1	Gear
61.7	8	Screw
61.8	1	Gear
61.9	1	Torque fork
61.10	1	Torque shaft
61.11	2	Potentiometer
61.12	1	Position shaft
61.13	1	Torque/Position plate

Figure 69. F01-3000 - Local Interface Assembly

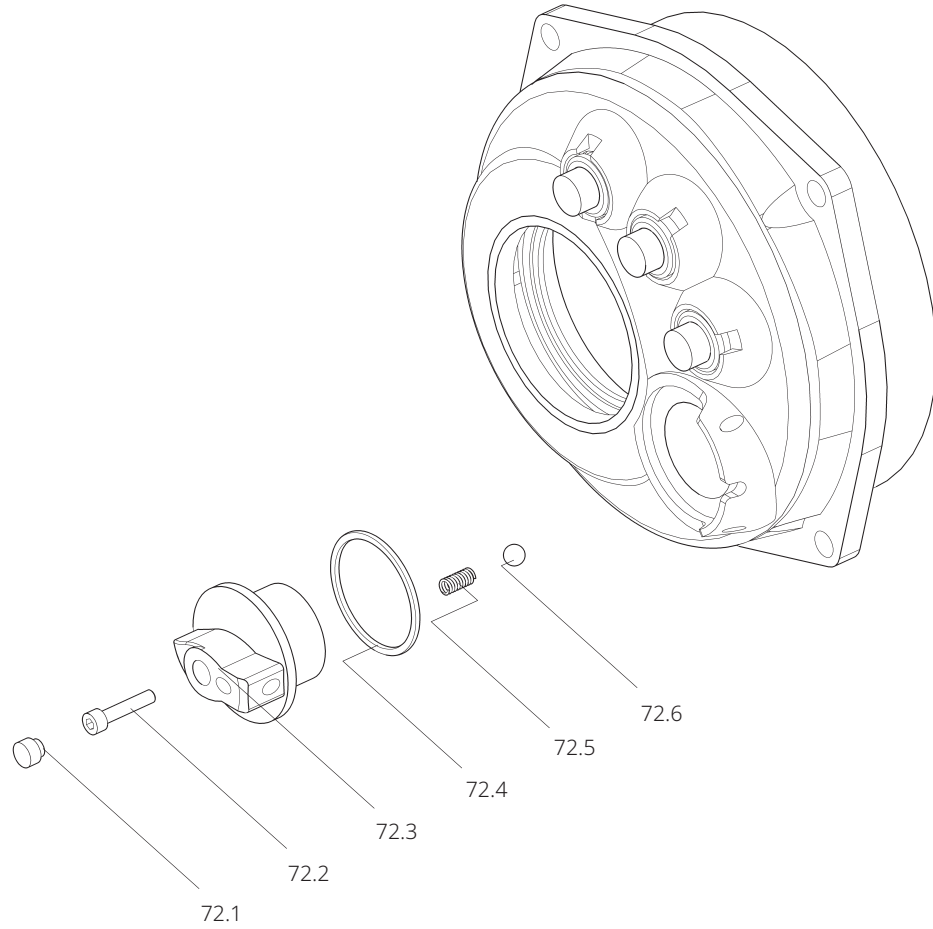

Table 22. Parts List

Item	Quantity	Description
72.1	1	Plug
72.2	1	* Screw
72.3	1	Selector
72.4	1	O-ring
72.5	1	* Spring
72.6	1	Ball

NOTE:

* Recommended spare parts

This page is intentionally left blank

Biffi Italia s.r.l.
Strada Biffi 165
29017 Fiorenzuola d'Arda (PC)
Italy
T +39 0523 944 411

For complete list of sales and manufacturing sites, please visit
www.biffi.it or contact us at biffi_italia@biffi.it

FCIM-20206-EN © 2025 Biffi. All rights reserved.

The contents of this publication are presented for information purposes only, and while every effort has been made to ensure their accuracy, they are not to be construed as warranties or guarantees, express or implied, regarding the products or services described herein or their use or applicability. All sales are governed by our terms and conditions, which are available on request. We reserve the right to modify or improve the designs or specifications of our products at any time without notice.

