

# CAM216/16 HART Instruction and Operation Manual





# Table of Contents

## Section 1: Introduction

1.1	HART CAM16/216 Specifications .....	1
1.2	HART Protocol and Device Description (DD) Information .....	2
1.3	Disclaimer .....	3
1.4	Actuator Description .....	3
1.5	Related Information .....	4
1.6	Specifications .....	4

## Section 2: Installation of CAM216

2.1	Installation of HART CAM16 in 320B M2CP Unit .....	6
2.2	Installation of HART CAM16 in HQ-DCM33 Unit .....	9
2.3	Installation of HART CAM16 in MPA Unit .....	11
2.4	Installation of HART CAM16 in EHO Unit .....	13

## Section 3: Installation of CAM216

3.1	Installation of HART CAM216 in TEC2000 Unit .....	21
-----	---	----

## Section 4: HART Quick Setup and Actuator Options

4.1	M2CP-320B Quick Setup Instructions.....	25
4.2	HQ-DCM33 Quick Setup Instructions.....	26
4.3	MPA Quick Setup Instructions .....	26
4.4	TEC2000, TEC2 and Model 500 Quick Setup Instructions .....	27

## Section 5: Detailed Setup and Options

5.1	Restarting the Actuator.....	29
5.2	Write Lock.....	29
5.3	Simulate.....	29
5.4	Calibrating Travel .....	29
5.5	Function Type .....	30
5.6	Actuator Command (On/Off) .....	30
5.7	Setpoint (Positioner) .....	30
5.8	ESD Command.....	31
5.9	Input Output Channel Listing .....	31
5.10	Actuator Options .....	32
5.11	Alarms and Status .....	32

## Section 6: Device Variables

6.1	Device Variables.....	37
6.2	Dynamic Variables .....	37

## Section 7: Status Information

7.1	Device Status .....	38
7.2	Additional Device Status .....	38

# Table of Contents (continued)

## Section 8: HART Commands Definition

8.1	Universal Commands .....	40
8.2	Common Practice Commands.....	41
8.3	Device Specific Commands .....	42

## Section 9: Device Descriptor

9.1	Procedure for Adding DD to AMS and 375/475.....	45
9.2	Overview Screen .....	56
9.3	Device Status Images .....	56
9.4	Device Information .....	57
9.5	Actuator Status .....	58
9.6	Manual Setup.....	58
9.7	Service Tools .....	59
9.8	Methods .....	61

## Section 10: Miscellaneous

10.1	Stroking the Actuator.....	62
------	----------------------------	----

## Section 11: Installation of Optional THUM Wireless Adapter

11.1	Component Installation on TEC2000, TEC2 and Model 500 .....	64
11.2	Component Installation on M2CP .....	67
11.3	Component Installation on MPA .....	69
11.4	Component Installation on EHO .....	70
11.5	Component Installation on HQ .....	71

## Section 12: THUM Programming and Wireless Setup

12.1	Set Up Gateway Internet Access for AMS Session .....	73
12.2	Set Up a Computer Using a HART Modem .....	73
12.3	THUM Programming – Join to Gateway Network Using a PC.....	73
12.4	Running AMS to Change the Device Setpoint .....	74
12.5	Return Network Settings to Original Settings after AMS Session.....	74

## Section 13: AMS Bulk Transfer

13.1	Create and export Bulk User Configuration File Template .....	75
13.2	Bulk Configuration Transfer Utility Procedure .....	78

## Section 14: Troubleshooting

14.1	Communication Issues .....	80
14.2	Control Issues .....	81

## Section 15: Trademark Acknowledgements

## Section 16: Document Revision

Revision Overview .....	83
-------------------------	----

# Table of Contents (continued)

## Appendix A: List of Certificates and Drawings

A.1	Certificate of Registration HCF Verified .....	84
A.2	Wiring Diagram for Controlinc320B with Analog-CAM16-HART .....	85
A.3	Wiring Diagram for TEC2 -3PH-CAM216-HART .....	86

# Section 1: Introduction

This manual contains specifications, installation, operating, and maintenance information for Communication Adapter Module (CAM216/16) Model No. 6 with HART option.

The CAM16 is used with Valve Automation M2CP, MPA, HQDCM33 and EHO valve actuators, whereas the CAM216 is used with the TEC2, TEC2000 and Model 500. Functionality of the actuator using the HART option supports both block valve (On/Off control) and modulating/positioning control. This manual also describes actuator setup using the HART specified Device Description (DD), parameter access, and methods. Display and control using these parameters depend on the SCADA or DCS host software being used. Refer to the host software documentation for information on executing methods and accessing parameters.

## 1.1 HART CAM16/216 Specifications

**Table 1. Card and Device Type**

Product Name	Expanded Device Type	Applicable Devices
CAM16	0xE28B (Hex)	M2CP
		MPA
		HQ
CAM216	0xE28C (Hex)	Model 500
		TEC2000
		TEC2
		EHO

**Table 2. General Device Information**

Type	Specifications
Manufacturer Name	Valve Automation
Manufacturer ID	0x6060 (Hex)
HART Protocol Revision	7.5
Device Revision	01
DD Revision	01

**Table 3. HART Device Variables**

Device Variable Code	Device Variable Name	Units
0	Setpoint	%
1	Position	%
2	Torque	%
3	Analog Input 1	%
4	Analog Input 2	%
5	Analog Output 1	%
6	Analog Output 2	%
7	Hydraulic Pressure	PSI (Pounds Per Square Inch)
8	Accumulator Pressure	PSI (Pounds Per Square Inch)

**Table 4. Dynamic Variables**

Sr. No.	Dynamic Variable	Default Assignment	Valid Range
1	Primary Variable	0: Setpoint	0: Setpoint
2	Secondary Variable	1: Position	0: Setpoint
			1: Position
3	Tertiary Variable	2: Torque	2: Torque
			3: Analog Input 1
			4: Analog Input 2
			5: Analog Output 1
			6: Analog Output 2
			7: Hydraulic Pressure
4	Quaternary Variable	3: Analog Input 1	2: Torque
			3: Analog Input 1
			4: Analog Input 2
			5: Analog Output 1
			6: Analog Output 2
			7: Hydraulic Pressure
			8: Accumulator Pressure

**Table 5. Device Physical Information**

Type	Specifications
Electrical Input	HART Interface
Voltage Level	10 to 18 VDC
Nominal Current	50 mA
Reverse Polarity Protection	Polarity Sensitive
Digital Communication Protocol	1200bps binary phase continuous Frequency Shift Keying (FSK)
Operating Ambient Temperature Limits	-40°C to 80°C (-40°F to 175°F)

## 1.2 HART Protocol and Device Description (DD) Information

Valve Automation electric motor actuators equipped with CAM16/216 option use HART protocol to communicate with other HART devices and a compatible host system. The HART Communications Protocol communicates over 4-20mA instrumentation cable which permits an easy upgrade path for legacy instrumentation systems to migrate into a digital industrial automation protocol.

A HART DD is used to describe the characteristics of the field device to the Host. For more details on the Device Descriptor (DD) please refer to [Section 9: Device Descriptor](#).

When manual installation of the DD is required, please refer to the Emerson Website to find the latest version of the HART CAM16/216 for download. Alternatively, the DD can be downloaded directly from the HART Foundation website at <https://en.hartcomm.org> for third party hosts.

Navigate to Technology | Device Descriptions | DD library | Product Catalogue | and locate the CAM16 or CAM216 DD respectively.

HART technology uses DD to achieve interoperability between actuators and control systems or hosts from various manufacturers. For HART devices, in addition to providing parameter definitions and information required by the control system to communicate with the HART device, the DD may also include methods.

## 1.3 Disclaimer

All rights reserved. No part of this document shall be reproduced, stored in a retrieval system, or transmitted by any means, electronic, mechanical, photocopying, recording, or otherwise without the express written permission of Valve Automation. While every precaution has been taken in the preparation of this document, the publisher and Valve Automation assume no responsibility for technical or editorial errors, omissions made herein; nor for incidental or consequential damages resulting from the performance or use of this document and the information, apparatus, or methods of operations disclosed within this document.

### **⚠ WARNING:**

Failure to follow instructions for proper electrical wiring, storage, setup, and maintenance may cause serious injury, damage equipment, or void the warranty. Refer to Manual E796 for instructions on storage, electrical hook-up and maintenance.

### **⚠ CAUTION:**

Actuator failure or integral electronic controller configuration or setup beyond that is described in this manual must be performed only by qualified Valve Automation personnel. Upgrades or reconfiguration of existing actuators must be performed only by qualified Valve Automation personnel. Repairs must be performed only by qualified Valve Automation personnel.

### **NOTE:**

Advisory and information comments provided to assist personnel through additional details and notable procedures

## 1.4 Actuator Description

Emerson Process Management electric actuators with HART option are microprocessor-based, interoperable, process controllers, communicating with other valve actuators and types of sensors and process control equipment. In addition to the primary function of controlling the position of the valve, the Emerson Process Management electric actuator, using HART communications protocol, gives easy access to information critical to process control. You can gain information from the principal component of the process, the control valve itself, by using a personal computer or operator's console within the control room.

Using a compatible HART configuration device, you can obtain information about the health of the actuator and valve. You can also obtain parameter access information about the actuator. You can set input and output configuration parameters and calibrate the actuator. Using the HART protocol, information from the actuator can be readily integrated into control systems and process control strategies.

## 1.5 Related Information

### 1.5.1 HART Installation and Guidelines

- HART Communication Protocol Specification (HCF\_SPEC-13)
- FSK Physical Layer Specification (HCF\_SPEC-54)
- Network Management Specification (HCF\_SPEC-85)

### 1.5.2 Other Related Information

Other documents containing information related to the Valve Automation Actuators include:

- Controlinc Quick Startup Guide, Document number ECL-400-1000
- Valve Automation series 2000 M2CP Installation and Maintenance Manual, Document number E796
- Multi-Port Actuator Operation and Manintenance Manual, Document number MPA-400-0711
- Digital Futronic HQ DCM 33 Operation Manual

## 1.6 Specifications

Specifications for the HART portion of the Valve Automation Actuator with CAM16/216 option are provided below. Refer to the Valve Automation series 2000 IOM Manuals for specifications on the basic Valve Automation actuator device.

- **Electrical Input**  
- HART Interface
- **Voltage Level**  
10 to 18 VDC
- **Nominal Current**  
50 mA
- **Reverse Polarity Protection**  
Unit is polarity sensitive and +/- is clearly marked for referencing. If the module is connected with reverse polarity, it will not operate and board may get damaged.
- **Digital Communication Protocol**  
1200 bps binary phase continuous Frequency Shift Keying (FSK)
- **Operating Ambient Temperature Limits**  
-40°C to 80°C (-40°F to 175°F)

---

### NOTE:

Temperatures below -40°C requires a low temperature actuator option.

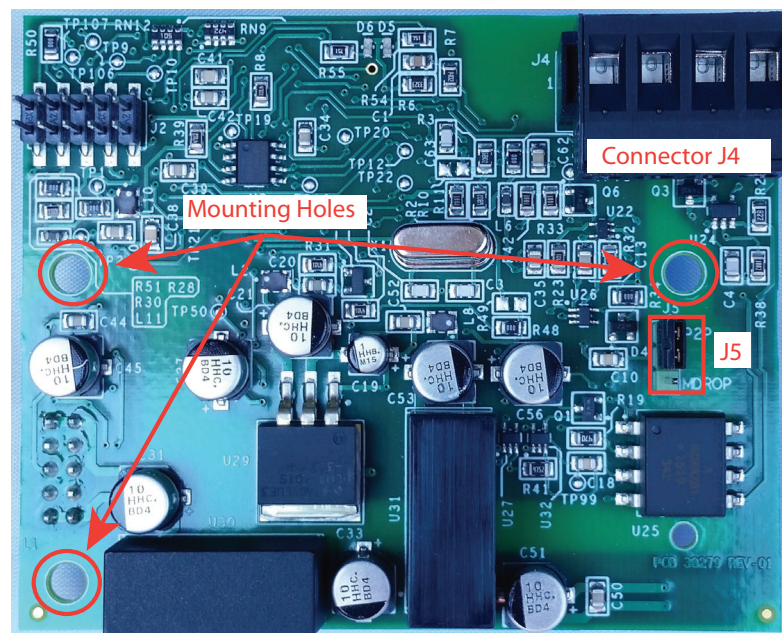
- 
- **Network Connection**  
Terminal Block with two elevator type screw terminals
  - **Auxiliary Digital Outputs**  
Quantity and Type – Two, Independent isolated Form 'A' dry contact relays  
Voltage – 250 VAC or 30 VDC  
Current – 5 Amps resistive, 2 Amps inductive

- **Auxiliary Digital Inputs**  
Quantity and Type – Two, Independent opto-isolated with high-side and low-side sensing  
Voltage – 10-30 VDC  
Current – 4 mA maximum turn-off, 10 mA minimum turn-on, 12 mA typical at 24 VDC
- **Auxiliary Analog Inputs**  
Two, 4-20 mA (24 VDC power available from actuator to power all auxiliary I/O)
- **Optional Analog Output** (Option must be specified at Time of Order)  
One, 4-20 mA

## Section 2: Installation of CAM16

CAM16 is supported by M2CP, HQ, EHO and MPA electric actuators when equipped with the proper networking features. Emerson Process Management electric actuators equipped with HART CAM16 option require a main power source. This source will power the electric motor and all electronic controls including the CAM16. The CAM16 HART interface is powered directly from the device, and is not capable of communication when the actuator does not have power. Refer to the site planning guide for proper wire types, termination and length into an Emerson Process Management electric actuator.

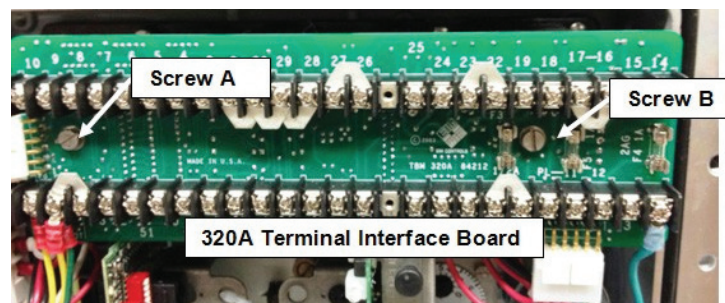
Figure 1 CAM16 Card



### 2.1 Installation of HART CAM16 in 320B M2CP Unit

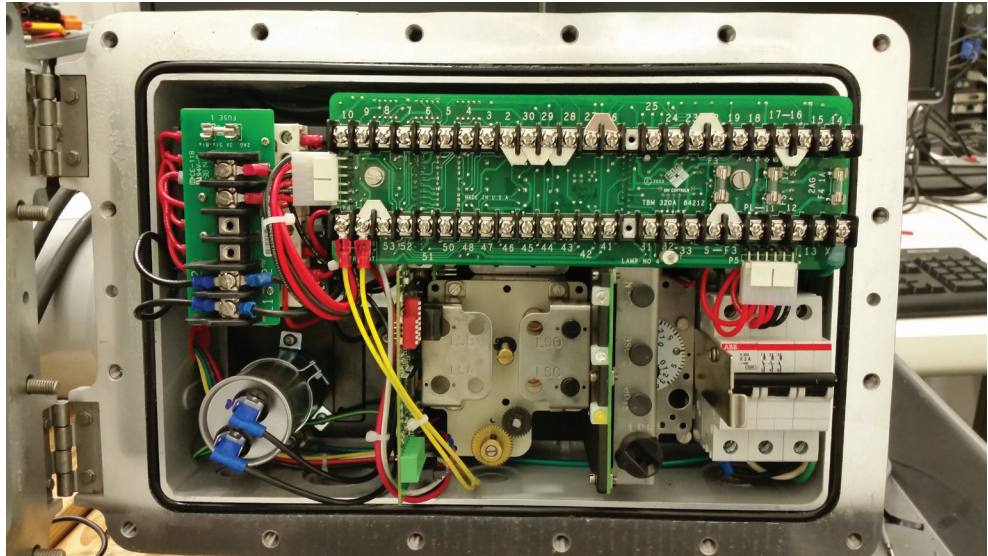
1. After removing power from the device, remove the front cover to expose the internal electronics. Locate and unplug the TBM 320A board located inside the control housing by loosening screws (A) and (B) and carefully pulling the board forward to expose the mounting location for the CAM16 board (no wires need to be disconnected).

Figure 2 CAM16 Screw Mounts



2. Lower the TBM 320A board without disconnecting the wires attached on the sides and bottom. This will provide access to the 320B board.

**Figure 3 Accessing the 320B Board**



3. Locate the J2 connector on the 320B Board, and connect to the J3 connection on the CAM16. Align the J2 to J3 and the 3 white plastic holders to mount the CAM16 in place.
4. Follow Step 5, 6 or 7 depending on desired HART Network type:

**Table 6. HART Control Types (1)**

Control Type	Step to Follow
HART – Analog Control (Point-to-Point)	Step 5
HART – Digital Control (Multi-Drop)	Step 6
HART – Digital Control (Wireless THUM)	Step 7

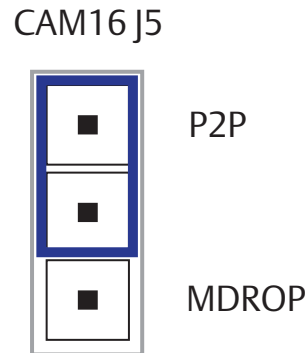
5. HART Analog Control (Point-to-Point; Actuator Must be in Analog Control Mode)
  - a. Connect the HART Analog 4 – 20 mA input signal as follows:

**Table 7. HART Control Types (2)**

4 – 20 mA	Connector J4, PIN 3
4 – 20 mA	Connector J4, PIN 4

- b. Select the Jumper J5 in P2P Mode.

**Figure 4 Jumper J5 Location**



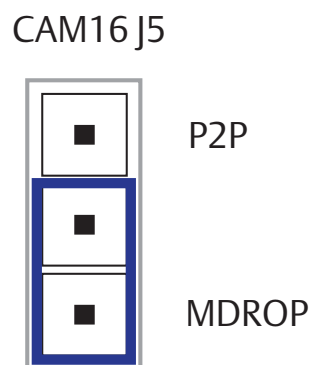
- c. For Analog mode, CAM16 – Connector J4, Pin 1 and 2 (CAM CARD 4 – 20 mA Output) should be connected to Pin 1 and Pin 2 (Analog Input 1) of Connector P1 of 320 B Board.
  - d. Ensure that all connections from step 5 are properly secured among CAM16, 320B board and the HART Input signal. Then, tighten the screws and proceed to close the unit.
6. HART Digital Control (Multi-Drop)
- a. Connect the HART Analog 4 – 20 mA input signal as follows:

**Table 8. HART Control Types (3)**

HART (+)	Connector J4, PIN 3
HART (-)	Connector J4, PIN 4

- b. Select the Jumper J5 in Multi-Drop Mode.

**Figure 5 Jumper J5 in Multi-Drop Mode**



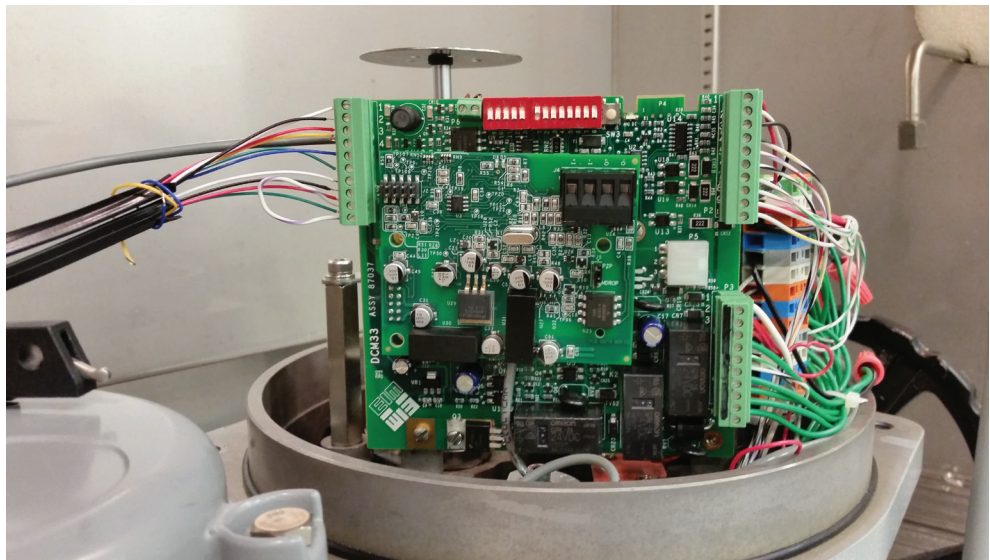
- c. Do the necessary changes in Host. It is important to make sure that all devices to be connected in this mode have a different HART address. The HART polling address can be found under the HART device information for each device. Make sure that you connect one device at the time while changing the addresses to avoid having devices with the same address on the network.

7. HART Digital Control (Wireless THUM)  
Refer to Section 12 for details about the THUM wiring and configuration.

## 2.2 Installation of HART CAM16 in HQ-DCM33 Unit

1. Remove power from the device and open the top main cover to expose the internal electronics. Locate the main DCM33 Board.
2. Locate J2 connector on DCM33 board and J3 connector on CAM16. Connect the CAM16 on the J2 connector. Then, secure the CAM16 board using the 3 plastic screw holders onto the DCM33 board.

**Figure 6 J2 Connection for CAM16**



3. Follow Step 4, 5 or 6 depending on your HART Network type:

**Table 9. HART Control Types (4)**

Control Type	Step to Follow
HART – Analog Control (Point-to-Point)	Step 4
HART – Digital Control (Multi-Drop)	Step 5
HART – Digital Control (Wireless THUM)	Step 6

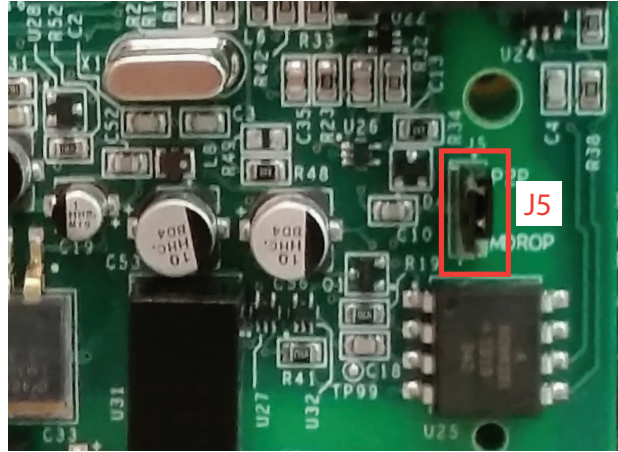
4. HART Analog Control (Point-to-Point; Actuator Must be in Analog Control Mode)
  - a. Connect the HART Analog 4 – 20 mA input signal as follows:

**Table 10. HART Control Types (2)**

4 – 20 mA	Connector J4, PIN 3
4 – 20 mA	Connector J4, PIN 4

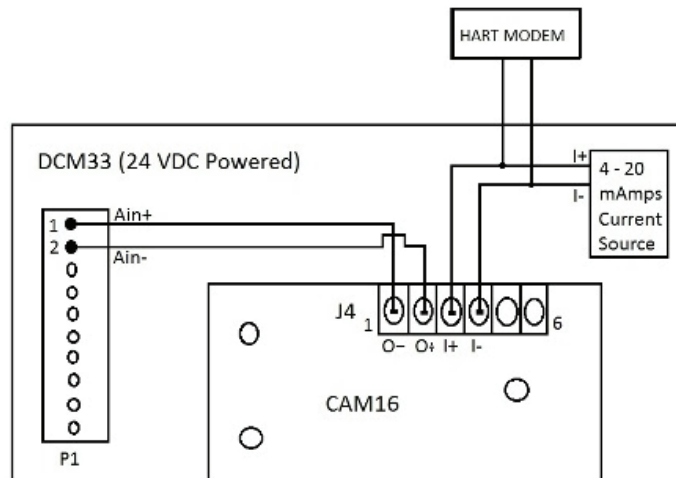
- b. Select the Jumper J5 in P2P Mode.

**Figure 7 Jumper J5 in P2P Mode**



- c. For Analog mode, CAM16 – Connector J4, Pin 1 and 2 (CAM CARD 4 – 20 mA Output) should be connected to Pin 1 and Pin 2 (Analog Input 1) of Connector P1 of 320 B Board.
  - d. Ensure that all connections from step 5 are properly secured among CAM16, 320B board and the HART Input signal. Then, tighten the screws and proceed to close the unit.
5. HART Digital Control (Multi-Drop):
- a. Connect the HART Analog 4–20 mA input signal as follows:

**Figure 8 Connection of CAM16 with 320B Board**



**Table 11. HART Control Types (6)**

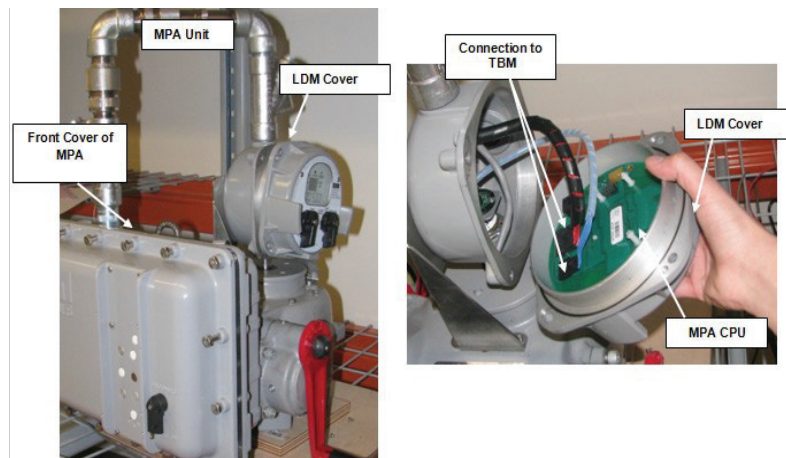
HART (+)	Connector J4, PIN 3
HART (-)	Connector J4, PIN 4

- b. Select J5 Jumper in Multidrop Mode.
  - c. Do the necessary changes in Host. It is important to make sure that all devices to be connected in this mode have a different HART address. The HART polling address can be found under the HART device information for each device. Make sure that you connect one device at the time while changing the addresses to avoid having devices with the same address on the network.
6. HART Digital Control (Wireless THUM):  
Refer to [Section 12](#) for details about the THUM wiring and configuration.

## 2.3 Installation of HART CAM16 in MPA Unit

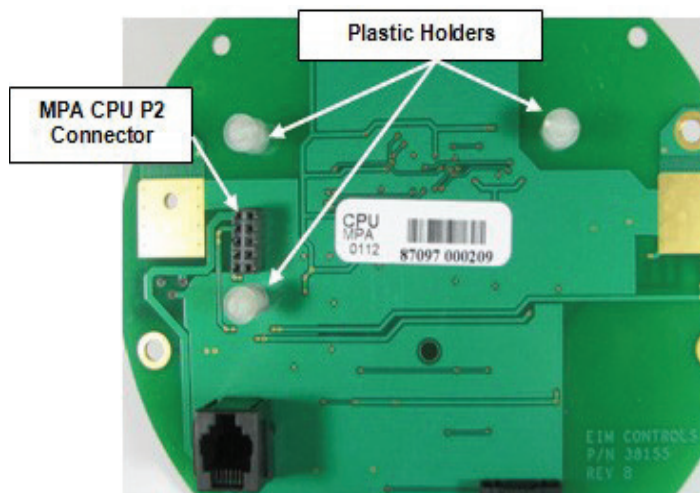
1. Remove power from the device and open the Local Display Module (LDM) by removing the 4 screws on each corner. Access the internal electronics and locate the MPA CPU on the back of the display. While opening the device, pay extra care to the connectors at back of the CPU.

**Figure 9 LDM Connectors**



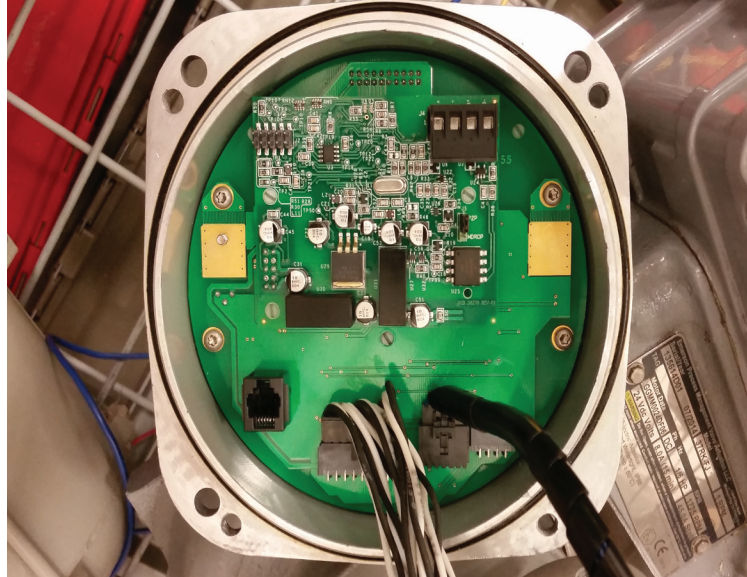
2. Locate the P2 connector on the MPA CPU and the 3 plastic holders:

**Figure 10 P2 Connector**



3. Connect CAM16 J3 into MPA CPU connector P2 and tighten the 3 plastic holders.

**Figure 11 CAM16 J3 Connection**



4. Follow step 5 or 6 depending on your HART Network type:

**Table 12. HART Control Types (7)**

Control Type	Step to Follow
HART – Analog Control (Point-to-Point)	Not Available
HART – Digital Control (Multi-Drop)	Step 5
HART – Digital Control (Wireless THUM)	Step 6

5. HART Digital Control (Multi-Drop):
  - a. Locate the networking port wires (in the back of the MPA CPU) and connect the appropriate wires to the CAM16 I+ and I- for the network port to be used for communications. Once selected, open the front cover of the MPA and connect your HART input to the desired networking port.

**Table 13. HART Control Types (8)**

CAM16 J4	MPA TBM
O-	20
O+	21
I-	22
I+	23

- b. Connect J5 Jumper in Multidrop Mode.

**NOTE:**

The network wires coming from the MPA TBM to the MPA CPU area may not be labeled, if so, verify that you are using the correct wires for the desired communication port.

- 6. HART Digital Control (Wireless THUM):  
Refer to Section 12 for details about the THUM wiring and configuration.

## 2.4 Installation of HART CAM16 in EHO Unit

### Steps for adding CAM16 (HART) Card in Smart EHO unit

- 1. Disconnect the actuator from the power source and open the Local Display Module (LDM) by removing the 4 bolts on each corner.

**Figure 12 LDM Cover Removal**

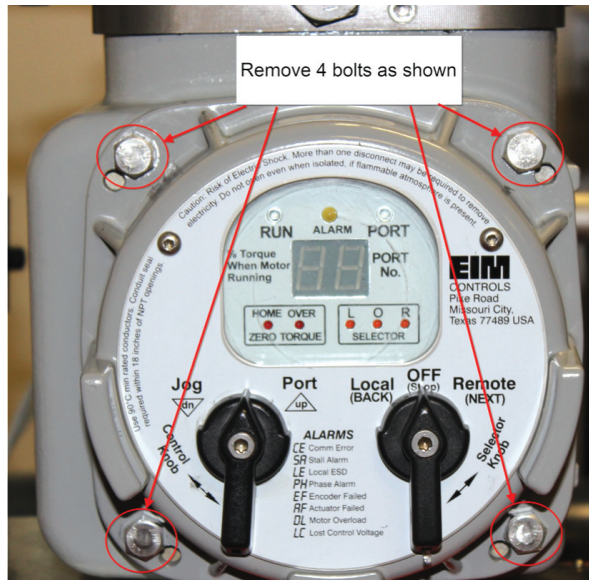
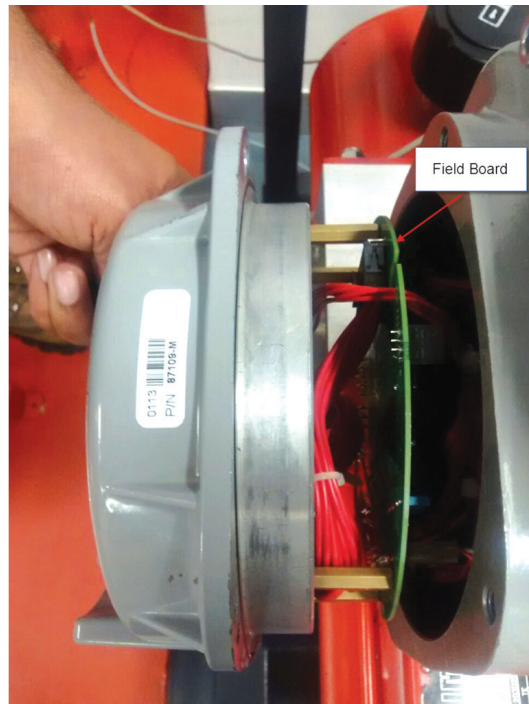
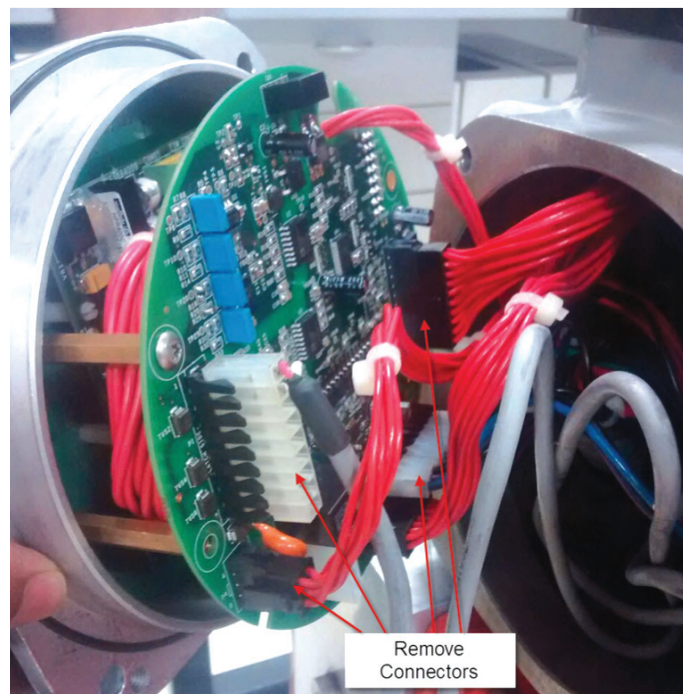


Figure 13 Side View of LDM Cover Removal



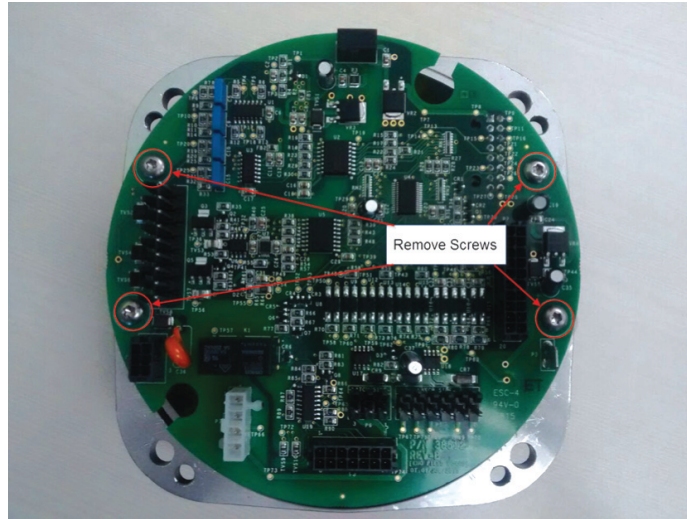
2. Separate the LDM assembly by disconnecting all the wire harnesses. Take care not to break any of the connectors.

Figure 14 LDM Wire Connectors



3. Separate the Field Board from the LDM assembly by removing the screws.

**Figure 15** LDM Board Screws

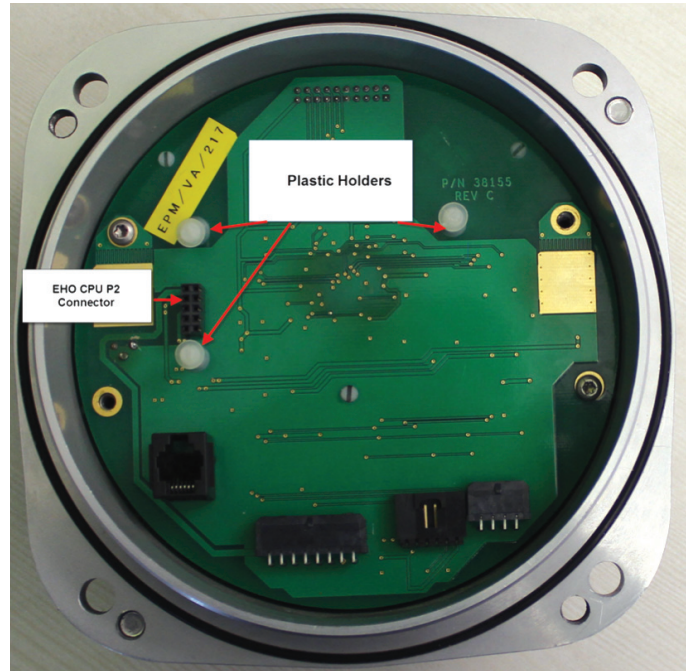


**Figure 16** LDM Board Interior



4. Locate the P2 connector on the EHO CPU and the three plastic holders. Connect CAM16 J3 into EHO CPU P2 while making sure to properly secure it using the 3 plastic holders. Check the image below for HART CAM16 Board installation.

**Figure 17** CAM16 J3 P2 Connector

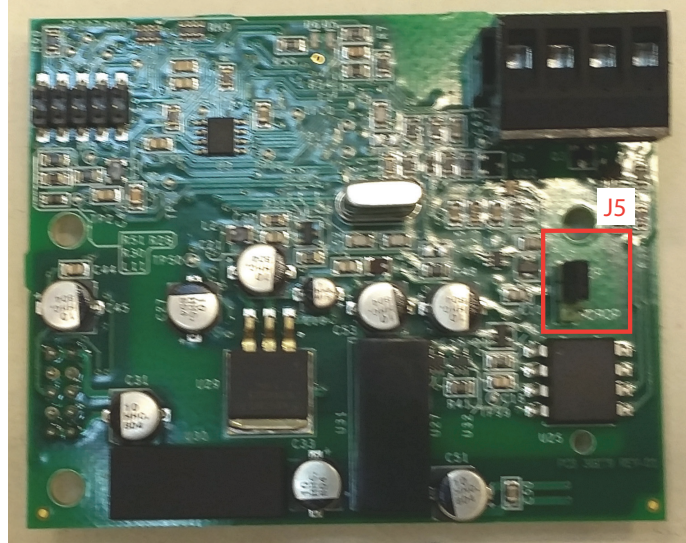


**Figure 18** HART CAM16 Field Board



- Once the CAM16 is installed on the EHO CPU Board, connect the custom cable (Part no. VA-ED-001-6238) to I (+), I (-), O (+) and O (-) respectively as per connection diagram given below:

**Figure 19 Custom Cable Connection**



**Figure 20 Connection Wiring Diagram**

**Connection Diagram Interfacing CAM16 with EHO**

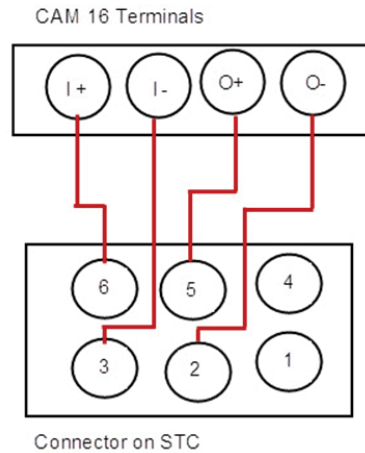
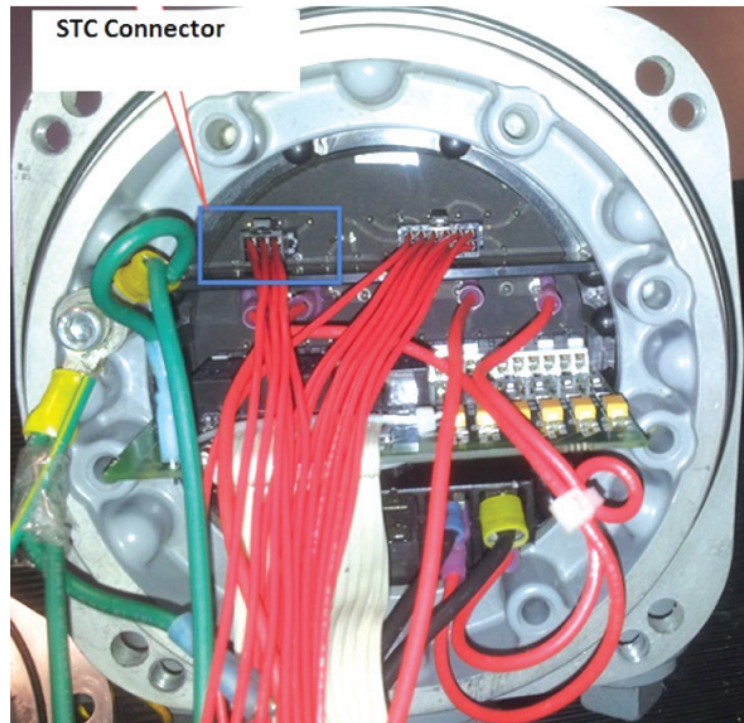


Table 14. STC Pins

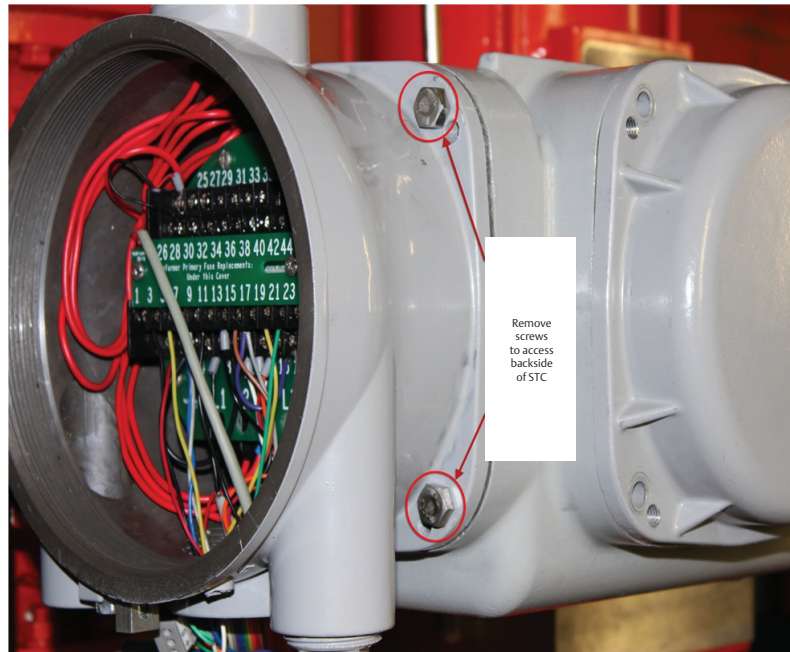
STC Pins	STC Back Pins	CAM card pins	HART Connection
41	5	J4(0+)	HART O+
42	2	J4(0-)	HART O-
43	6	J4(I+)	HART I+
44	3	J4(I-)	HART I-

Figure 21 CAM16 J3 STC Connection



6. To connect the other end of the wire harness to STC  
On the CAM16, locate connector J4 and make sure that it is securely connected to the inside of the actuator using a 6-wire connector. This connector provides the communication between the LDM and the STC on the EHO, if missing or not properly connected; you will not be able to establish communication to your device  
The wire harness fits into the 6-pin micro-fit connector on the inner side of the STC. Temporarily separate the STC from the EHO enclosure by removing 4 bolts, so that it will be easy to connect the wire harness. Plug the wire harness into the 6-pin housing connector on the STC's back side and reinstall the STC assembly.

**Figure 22** CAM16 J3 Connection for EHO STC



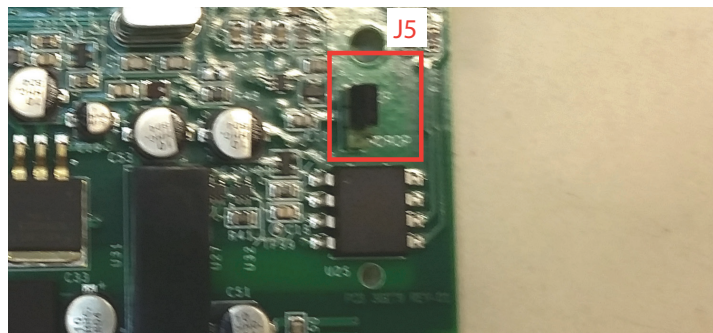
7. Reassemble the Field Board with connectors.
8. Reinstall the LDM assembly back to the EHO unit.
9. Now follow steps 10, 11 or 12 depending on your HART network type.

**Table 15. HART Control Types (8)**

Control Type	Steps to Follow
HART - Analog Control (Point to Point)	Step 10
HART - Digital Control (Multi Drop)	Step 11
HART - Digital Control (Wireless THUM)	Step 12

10. HART – Analog Control (Point to Point; Actuator Must be in Analog Control Mode)
  - a. Connect the HART 4-20 mA signal to the STC Pin 43 and 44. The 4–20 mA output would be available at STC Pin 41 and 42. These output pins must be connected to the actuator’s analog input 1 STC Pin 25 and 26.
  - b. Connect Jumper J5 in P2P

**Figure 23** CAM16 J5 Jumper



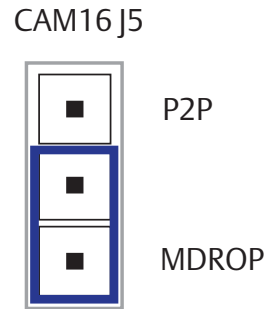
11. HART – Digital Control (Multi-Drop)

**Table 16. HART Control Types (9)**

HART Connection	Pins
HART (+)	STC Pin 43
HART (-)	STC Pin 44

- a. It is important to make sure that all devices to be connected in this mode have a different information for each device. Make sure that you connect one device at a time while changing the addresses as to avoid having devices with the same address on the network.
- b. Connect J5 Jumper in Multidrop Mode

**Figure 24 CAM16 J5 Configured for Multidrop Mode**



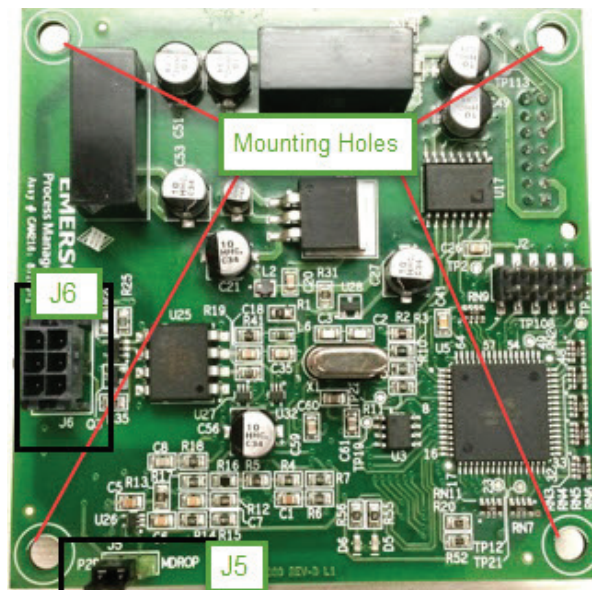
- 12. HART – Digital Control (Wireless THUM)  
Refer to [Section 12](#) for details about the THUM wiring and configuration.
- 13. Switch ON the power to the unit.
- 14. Through LDM Menu;
  - a. Set Control Mode(CO) to 7 (Network)
  - b. Set the Network Adapter Parameter (nA) to 9 (HART Block Mode) or 10 (HART Modulation Mode) (Refer LDM Flow document for navigation)
- 15. Save the settings

## Section 3: Installation of CAM216

Emerson Process electric actuators equipped with HART CAM216 option require a main power source. This source will power the electric motor and all electronic controls including the CAM216. The CAM216 HART interface is powered directly from the device, and is not capable of communication when the actuator does not have power. Refer to the site planning guide for proper wire types, termination, length, and others into an Emerson Process Management electric actuator.

The CAM216 is supported by the TEC2000, TEC2 and Model 500 electric actuators equipped with Auxiliary Control Module (ACM) and proper wiring. For more information about installing the ACM, refer to TEC2000 Installation and Operation Manual E2K-405-0703.

**Figure 25** CAM216



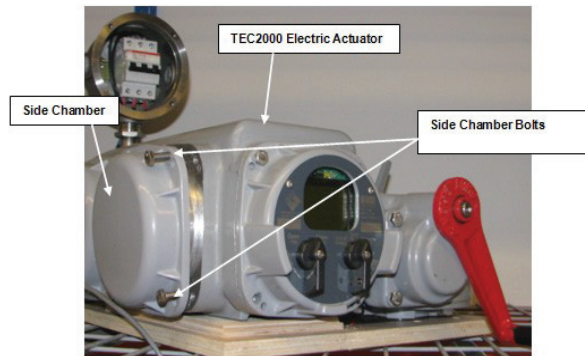
### 3.1 Installation of HART CAM216 in TEC2000 Unit

1. Remove power from the device and open the frontal side chamber on the TEC2000 by removing the 4 bolts located on each corner. After removing the bolts, pull the side chamber outwards to gain access to the ACM. If it is difficult to remove, you might assist the removal of the chamber by driving in the removed bolts on the threaded corner openings to help the cover “push” itself out as you drive in the bolts.

Figure 26 CAM216 in TEC2000

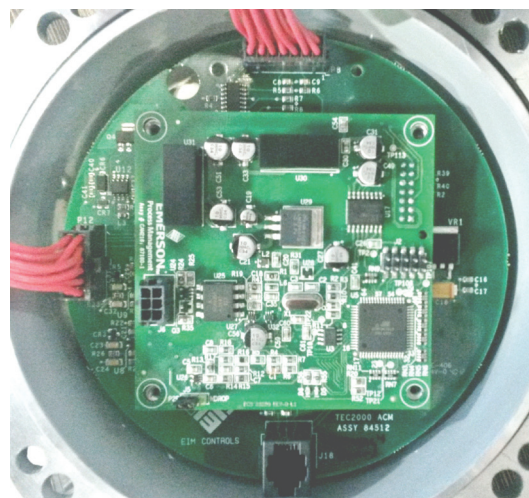


Figure 27 Front View of TEC2000



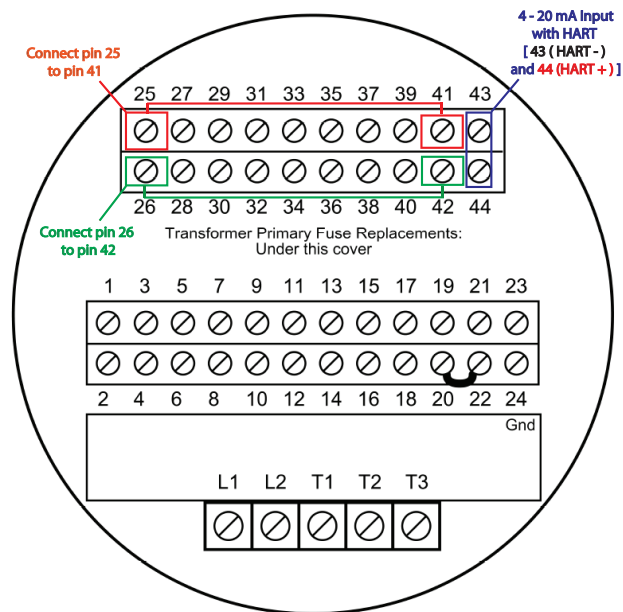
2. Once the chamber is open, locate the ACM inside it and verify that connections P12 and P8 or any other connections (if equipped) were not accidentally disconnected in the process. Locate connector P17 and the openings to mount the CAM216 holders. Mount the CAM216 into the ACM using the 4 holders in the corners making sure that connector J7 on CAM216 is properly aligned to P17 on the ACM then proceed to tighten the CAM216 holders.

Figure 28 CAM216 in the ACM



3. On the CAM216, locate connector J6 and make sure that it is securely connected to the inside of the actuator using a 6-wire connector. This connector provides the communication between the ACM and the STC on the TEC2000, if missing or not properly connected, you will not be able to establish communication to your device.

**Figure 29** TEC2000 Sealed Terminal Chamber Pin Diagram



4. Now that the CAM216 is in place, close and bolt down the ACM chamber. Then, locate the Separate Terminal Chamber (STC) on the back of the TEC2000. Then, follow step 5, 6 or 7 depending on your HART Network type:

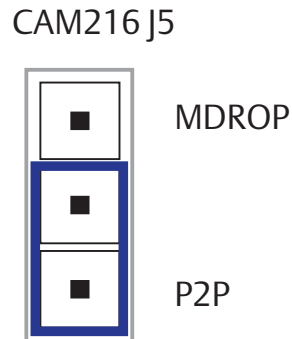
**Table 17.** HART Control Types (9)

Control Type	Step to Follow
HART – Analog Control (Point-to-Point)	Step 5
HART – Digital Control (Multi-Drop)	Step 6
HART – Digital Control (Wireless THUM)	Step 7

5. HART Analog Control (Point-to-Point; Actuator Must be in Analog Control Mode):
  - a. Connect the HART 4-20 mA signal to the STC Pin 43 and 44. The 4–20 mA output would be available at STC Pin 41 and 42. These output pins must be connected to the Actuator’s Analog Input 1 STC Pin 25 and 26.

- b. Connect J5 Jumper in P2P Mode.

**Figure 30 J5 Jumper in P2P Mode**



- 6. HART – Digital Control (Multi-Drop; Actuator Must be in Network Control Mode):  
It is important to make sure that all devices to be connected in this mode have a different HART address. The HART polling address can be found under the HART device information for each device. Make sure that you connect one device at the time while changing the addresses as to avoid having devices with the same address on the network. Connect J5 Jumper in Multidrop Mode.

Connection shall be as follows –

**Table 18. HART Control Types (10)**

HART(+)	STC Pin 43
HART(-)	STC Pin 44

- 7. HART Digital Control (Wireless THUM; Actuator Must be in Network Control Mode):  
Refer to Section 12 for details about the THUM wiring and configuration.
- 8. Modbus Channel on CAM216:  
CAM216 also supports one Modbus channel. Please refer to TEC2000 STC Image and Pin 39 and 40 would be used for RS 485 connection.

**Table 19. HART Control Types (11)**

MODBUS(+)	STC Pin 40
MODBUS(-)	STC Pin 39

# Section 4: HART Quick Setup and Actuator Options

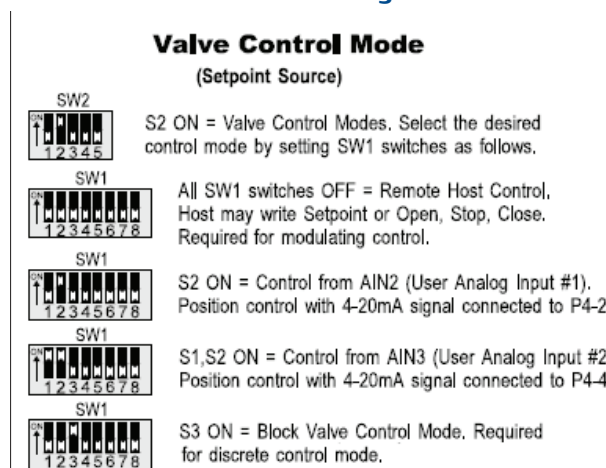
The Emerson Process Management Electric Actuators must have mechanical valve travel and torque switches set first. Refer to Manual E796 to perform these adjustments.

## 4.1 M2CP-320B Quick Setup Instructions

The M2CP-320B is factory configured as specified by the customer purchase order. If field setup changes are required, follow the setup instructions as mentioned below.

- Entering Setup Mode:**  
Locate DIP switches SW1, SW2, and SW3 (Execute button) on the DCM 320B board and make a note of the original configuration of the switches before making modifications. SW1 selects mode, SW2 selects respective setup parameters and SW3 sends the changed configuration. Place the selector switch in the OFF position and select desired setup mode by setting SW2. Please refer to Controlinc Quick Startup Guide for DCM320B. If done correctly, you will see a rapid flashing CPU GOOD indicator.
- Valve Control Mode:**  
Enter the following configuration on SW1 and SW2 to change the Valve Control settings:  
Set both SW1 and SW2 switches as indicated below and press the execute button to store the setup parameter to non-volatile memory.

Figure 31 Valve Control Mode Switch Settings



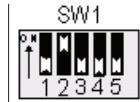
- Exiting Setup Mode:**  
To exit Setup mode, place SW1 and SW2 back to the original configuration and press the execute button. If successful, CPU GOOD will return to a slow and steady flashing.

## 4.2 HQ-DCM33 Quick Setup Instructions

The DCM33 is factory configured as specified by the customer purchase order. If field setup changes are required, follow the setup instructions as mentioned below.

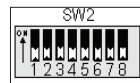
- Entering Setup Mode:**  
Locate DIP switches SW1, SW2, and SW3 (Execute button) on the DCM33 Board and make a note of the original configuration of the switches before making modifications. SW1 selects mode, SW2 selects respective setup parameters and SW3 sends the changed configuration. Place selector switch in the OFF position and select desired setup mode by setting SW1 and SW2. Please refer Controlinc Quick Startup Guide for DCM33. If done correctly, you will see a rapid flashing CPU GOOD indicator.
- Valve Control Mode:**
  - Enter the following configuration on SW1 to change the valve control settings:

**Figure 32 Valve Control Switch Settings**



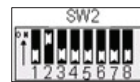
- For Network Control Mode (Host), set all switches to the OFF position as shown below:

**Figure 33 Network Control Mode Switch Settings**



- For Analog Input Control (4-20mA), set switches as shown below:

**Figure 34 Analog Input Control Switch Settings**



- When both SW1 and SW2 switches are set, press the execute button to store the setup parameter to non-volatile memory.
- Exiting Setup Mode:**  
To exit Setup mode, place SW1 and SW2 back to the original configuration and press the execute button. If successful, CPU GOOD will return to a slow and steady flashing.

## 4.3 MPA Quick Setup Instructions

The MPA is factory configured as specified by the customer purchase order. If field setup changes are required, follow the setup instructions as mentioned below. Operating modes for the MPA may be setup by using the MPA CONFIG Software or by navigating on the LDM setup menu.

1. **Setup Mode Display Sequence:**  
The three (3) amber LED's for the LOR section flash to indicate Setup Mode. When in setup mode, the user must enter the REMOTE(NEXT) or LOCAL(BACK) within 120 seconds or the display will revert back to the normal display mode.

Setup data may be changed by using the UP and Down entries of the Control Knob. The UP and Down entries are active only after a valid pass-code is entered and the Selector Switch is in the STOP position. The default pass-code is P1 00 and P2 00. Once the correct pass code is entered and accepted at the actuator controls, the user will then be able to advance through the displays shown in the Main Menu table:

**Table 20. Main Menu Table**

Menu	Parameter	Value	Units	Default
C0	Control Mode	0-1	0=Discrete 1=Network	1

- The table on the following page shows the sequence of the setup menus. It also shows the selections, units, and defaults. Each time the REMOTE (NEXT) selector knob is selected, the display advances to the next menu item. Each time the LOCAL (BACK) selector knob is selected, the display backs up to the previous menu item. The UP and DOWN control knob is used to increment or decrement the value shown in the table.

Once in setup mode, navigate through the menus and verify that the proper setup is configured.

**NOTE:**

RDM port configuration is fixed at 9600 Baud rate, None Parity Bit, 8 Data Bits, 1 Stop Bit and Network Address 254 and may not be changed by the user. Only the network port configuration may be changed. The address programmed for the network port will be accepted by the RDM port in addition to address 254.

## 4.4 TEC2000, TEC2 and Model 500 Quick Setup Instructions

The TEC2000 is factory configured as specified by the customer purchase order. If field setup or factory configuration changes are required, contact your nearest Emerson Process Management representative for assistance. Only authorized Emerson Process Management Representative or trusted partner should make modification to factory settings. Operating modes for the TEC2000 may be reviewed by using DCMLink software or by navigating on the LDM Setup menu. As a minimum, the Network Adapter must be set for HART (On/Off) (Block) mode or the HART Positioner (Analog) (Modulating) mode. Valve Position Feedback must be calibrated for either device type by stroking the valve from the CLOSE to OPEN and OPEN to CLOSE limits with selector switch in the LOCAL mode.

You can set or verify the following information by setting up DCMLink on the device or by navigating on the LDM Setup menu.

**Setup through LDM:**

First, locate the Selector knob (Local, off, remote) and the control knob (Open, Close) on the front of the LDM. You will use the Control knob to answer “yes” or “no” at prompts on screen during setup. You will use the selector knob to navigate “back” or “next” through the menu options.

1. Place the Selector Knob in OFF, then; move the control knob in the following order within 3 seconds: open, close, open, close, open, and close. If done correctly, "Setup?" will appear on screen.
2. By Moving the Control Knob, navigate to Setup -> Display Unit Parameters -> Control Mode and verify that "Network" or "Analog" is selected as required. Select "Next" and verify that "Network Adapter" shows "HART Block" or "HART Modulation" mode.
3. Make sure the Network "Response Delay" parameter; set to 8 mSecs.
4. Place the Selector Knob in BACK and wait until it reaches to "Setup?" then move the Control Knob to "NO" and you will be exited from the Setup Mode.

## Section 5: Detailed Setup and Options

The actuator must be set up as defined in Section 4.4, prior to performing the following detailed setup.

### 5.1 Restarting the Actuator

You can restart the Actuator by turning off and on the main power source. The process of restarting the actuator should be done cautiously because the CAM card is directly powered from the device and is not able to communicate when the actuator does not have power.

#### **⚠ WARNING: DO NOT RESTART AN ACTIVE ACTUATOR**

Restarting the actuator may cause loss of control of the process.

5.1.1 Restarting HART Interface

5.1.2 When the HART Interface is restarted using Device Reset Option (Service Tool -> Maintenance -> Reset)

### 5.2 Write Lock

If the actuator is write protected, that means it will prevent any external change to the static or non-volatile data. It shall not be possible to remove write protect from Network (via DD or Application software). This is due to the security restrictions. To disable write protect, user must use the Actuator knobs / DIP switches. Please refer to Device Instruction Operation Manual to know about disabling the write protect.

### 5.3 Simulate

CAM16/216 does not support simulation.

### 5.4 Calibrating Travel

You must calibrate the actuator manually after the mechanical valve travel limits are set or changed. Calibration is required only one time after the travel limits are set or changed. Calibration parameters are stored in a non-volatile memory, which holds the variables when power is removed from the actuator.

5.4.1 Calibration Procedure

1. Place the LOR selector switch to the “LOCAL/MANUAL” mode.
2. Set travel limit switches as per the valve travel on which the actuator is attached. Refer to VALVE AUTOMATION Manual E796 for “Limit Switch Setting Instructions”.
3. Stroke the valve fully CLOSED, OPEN, and CLOSED using the local push buttons.
4. The actuator automatically calibrates the “Position Feedback” from 0 to 100% scale and makes this data available to the HART Interface.
5. Place the LOR selector switch in the “Remote/Auto” mode to return control to the HART Interface.

---

**NOTE:**

Calibration may be executed remotely by placing the selector switch in the REMOTE/AUTO mode and commanding the actuator to close and then open and then close. The actuator will automatically calibrate "Position Feedback" to the valve travel limits and make this information available to the HART Interface. Both methods of calibration will move the actuator to determine the end of travel points for the actuator. The actuator must move to each limit of travel (fully open and fully close) or else the calibration will not be completed.

---

## 5.5 Function Type

The function type is defined by the parameter Function Type and defines the type or mode of operation of the actuator. The two types allowed are BLOCK and MODULATING.

The Function Type – BLOCK is for on/off or Block type actuation of a valve. The Function Type – MODULATING is for Positioner or Modulation type of valve actuation.

## 5.6 Actuator Command (On/Off)

The Actuator Command is only available when the actuator is configured for Block Mode (On/Off). Actuator Command is used to command the actuator to the desired position of "Closed", "Opened" or "Stop". If the actuator is commanded to its "Open" or "Closed" position, it will remain in that position and will attempt to maintain that position except if something happens to the actuator to cause the position to change, for instance if someone would try to move the valve using the hand wheel. Once the actuator detects the position has changed, it will attempt to move the actuator back to its commanded position. If the Hand wheel position is desired, then the actuator must be placed in LOCAL/MANUAL.

If the actuator is given a "Stop" command, it will stop processing position data and will not command the actuator to any position and will not adjust except the current position change due to external influences. This command is used to manually position the actuator.

## 5.7 Setpoint (Positioner)

The Setpoint Command is only available when the actuator is configured for Modulating Mode (Positioner). Setpoint is used to command the actuator to the desired position. The command is represented as a percentage of the full travel of the device. The actuator will remain in the commanded position (+/- Dead band) and will attempt to maintain that position except when something happens to the actuator to cause the position to change. For instance, if someone would try to move the valve using the Hand wheel, the position may change. Once the actuator detects the position has changed, it will attempt to move the actuator back to its commanded position. To move the actuator via another means, the actuator selector switch must be placed in the Local/Manual or OFF position.

### 5.7.1 Dead band

An integral part of the Setpoint command is Dead band or Position Control Bandwidth. Dead band is handled internally by the DCM and is a basic function of actuator internal inertia, load inertia and the actuator motor starter. The Position Control Bandwidth can be set in the DCM with value between 0.1% to 5.0%. Under most circumstances, the actuator will require one of two options to use a Position Control Bandwidth less than the default value of 1.0%. Both of these are additions to the electro-mechanical reversing contactor.

The first option is the solid-state reversing starter, which will allow a higher degree of accuracy of control, and as such, a smaller degree of Dead band. The second option is a Variable Frequency Controller, which is used for the highest degree of accuracy and the smallest degree of Dead band. The DCM also has a setup for these optional motor starter types and must be set up for them. For more information, please refer to the Valve Automation Controlinc Quick Startup Guide.

## 5.8 ESD Command

This command is available with the device is in both Modulating and Block Modes. This command overrides all other commands and forces the actuator to a pre-selected position, CLOSE, OPEN, or STAY-PUT. These pre-selected positions are options that can be set on the DCM. If the DCM has ESD set and the actuator is commanded into ESD, the actuator will not respond to any other movement commands until the ESD command is removed.

**NOTE:**

“ESD on lost communication” feature is not available when using HART CAM16/216 since the HART board maintains power even after it is cut off from the host and polling of the actuator continues.

## 5.9 Input Output Channel Listing

**Table 21. Input Output Channel Table**

Parameters	MPA	M2CP 320B	HQDCM33	TEC2000	TEC2 / Model 500	EHO
Analog Input 1	N/A	Yes	Yes	Yes	Yes	Yes
Analog Input 2	N/A	Yes	N/A	Yes	Yes	Yes
Analog Output 1	N/A	Yes	Yes	Yes	Yes	Yes
Analog Output 2	N/A	N/A	N/A	N/A 1	Yes 2	Yes
Discrete Input 1	N/A	Yes	Yes	Yes	Yes	Yes
Discrete Input 2	N/A	Yes	Yes	Yes	Yes	Yes
Discrete Input 3	N/A	N/A	N/A	Yes	Yes	Yes
Discrete Input 4	N/A	N/A	N/A	Yes	Yes	Yes
Discrete Input 5	N/A	N/A	N/A	Yes	Yes	Yes
Discrete Input 6	N/A	N/A	N/A	Yes	Yes	Yes
Relay 1	N/A	Yes	N/A	Yes	Yes	Yes
Relay 2	N/A	Yes	N/A	Yes	Yes	Yes
Relay 3	N/A	N/A	N/A	Yes	Yes	Yes
Relay 4	N/A	N/A	N/A	Yes	Yes	Yes
Relay 5	N/A	Yes	N/A	Yes	Yes	Yes

**NOTE:**

- For HART CAM Card, Analog Output 2 is not applicable. The reason for this is, CAM Boards can only be mounted on the Controlinc ACM. The Controlinc ACM supports only 2 Analog Inputs and 1 Analog Output
- Unlike TEC2000, TEC2 has a separate ACM called TEC2 ACM and it supports 2 Analog Inputs and 2 Analog Outputs as well

## 5.10 Actuator Options

The actuator may or may not contain any one or all of the following options:

- Phase Monitor – Phase monitors are not required for actuators with single-phase motors and may not be installed in some actuators with three-phase power. If this option is not installed, then the “Phase Monitor Alarm” of the “Actuator Status” will be inactive. As such, the Phase Monitor alarm will always be “Zero” or “Off”.
- Analog Torque Transducer – If this option is not installed in the actuator, the “Torque” analog channel is not available. The “Open Torque Alarm” and “Close Torque Alarm” are always active from the torque limit switches.
- Analog Auxiliary Output 1 – If this option is not installed, then “Analog Auxiliary Output 1” is not available. The actuator must have the optional 320B-2 module installed to make this option available.
- Torque Parameter - If the optional transducer is installed, it will provide the instantaneous torque being generated by the actuator to the valve stem. The torque value is expressed as a percentage of full scale of the rated torque of the actuator from – 0% (normally closing) to 100% (normally opening). For TEC2, Model 500 and EHO electric actuators, torque is a standard feature. For M2CP, it is optional and must be specified when placing an order. For HQ actuator, torque options are not available.

## 5.11 Alarms and Status

There are no dedicated channels for Status and Read back; however, alarms can be monitored from the DD. The following table depicts the applicability of each Field Device Alarm, with respect to Actuators. These Alarms are mapped to Command #48 Response Bytes.

**Table 22. Alarm Types (1)**

Field Device Alarms	Actuators					
	MPA	M2CP 320B	HQDCM33	TEC2000	TEC2 / Model 500	EHO
Actuator Fail Alarm	Yes	Yes	N/A	Yes	Yes	Yes
Phase Monitor Alarm	Yes	Yes	N/A	Yes	Yes	Yes
Motor Thermal Alarm	Yes	Yes	N/A	Yes	Yes	Yes
Power Monitor Alarm	Yes	Yes	N/A	Yes	Yes	Yes
Moving Wrong Direction	Yes	N/A	N/A	N/A	N/A	N/A
CCM Failure Alarm	N/A	N/A	N/A	Yes	Yes	N/A
LDM Failure Alarm	N/A	N/A	N/A	Yes	Yes	Yes
APD Failure Alarm	N/A	N/A	N/A	Yes	Yes	N/A
RDM1 Failure Alarm	N/A	N/A	N/A	Yes	Yes	Yes
RDM2 Failure Alarm	N/A	N/A	N/A	Yes	Yes	Yes
Hydraulic Power Unit Fault Alarm	N/A	N/A	N/A	N/A	N/A	Yes
Solenoid Valve Fault Alarm	N/A	N/A	N/A	N/A	N/A	Yes

**Table 23. Alarm Types (2)**

Field Device Alarms	Actuators					
	MPA	M2CP 320B	HQDCM33	TEC2000	TEC2 / Model 500	EHO
Pressure Transmitter Fault Alarm	N/A	N/A	N/A	N/A	N/A	Yes
Encoder Fault Alarm	N/A	N/A	N/A	N/A	N/A	Yes
Communication Failed Alarm	Yes	Yes	Yes	Yes	Yes	Yes
Electronics Fault Alarm	N/A	N/A	N/A	Yes	Yes	N/A
Initialization Failed Alarm	Yes	Yes	Yes	Yes	Yes	Yes
Compatibility Error	Yes	Yes	Yes	Yes	Yes	Yes
Over Pressure in Mid Travel Alarm	N/A	N/A	N/A	N/A	N/A	Yes
Analog Input 1 Out Of Range	N/A	Yes	Yes	Yes	Yes	Yes
Analog Input 2 Out Of Range	N/A	Yes	N/A	Yes	Yes	N/A
Close Torque Alarm	N/A	Yes	Yes	Yes	Yes	Yes
Open Torque Alarm	N/A	Yes	Yes	Yes	Yes	Yes
Over Torque Alarm	Yes	N/A	N/A	Yes	Yes	Yes
Overshoot Alarm	Yes	N/A	N/A	N/A	N/A	N/A
Stop between Ports Alarm	Yes	N/A	N/A	N/A	N/A	N/A
Hardwired ESD Alarm	Yes	Yes	Yes	Yes	Yes	Yes
Host Command ESD Alarm	Yes	Yes	Yes	Yes	Yes	Yes
Lost Analog Input 1 Alarm	N/A	N/A	N/A	Yes	Yes	Yes
Lost Analog Input 2 Alarm	N/A	N/A	N/A	Yes	Yes	N/A
Backup Power Alarm	N/A	N/A	Yes	N/A	N/A	N/A
Valve Stall Alarm	Yes	Yes	Yes	Yes	Yes	Yes
Partial Stroke Test Fail Alarm	N/A	N/A	N/A	N/A	N/A	Yes

Table 24. HART Specific Alarms

Field Device Alarms	Actuators					
	MPA	M2CP 320B	HQDCM33	TEC2000	TEC2 / Model 500	EHO
Primary Variable Out of Limit	Yes	Yes	Yes	Yes	Yes	Yes
Non-Primary Variable Out of Limit	Yes	Yes	Yes	Yes	Yes	Yes
Loop Current Saturated	Yes	Yes	Yes	Yes	Yes	Yes
Loop Current Fixed	Yes	Yes	Yes	Yes	Yes	Yes
More Status Available	Yes	Yes	Yes	Yes	Yes	Yes
Cold Start	Yes	Yes	Yes	Yes	Yes	Yes
Configuration Changed	Yes	Yes	Yes	Yes	Yes	Yes
Device Malfunction	Yes	Yes	Yes	Yes	Yes	Yes
Maintenance Required	Yes	Yes	Yes	Yes	Yes	Yes
Device Variable Alert	Yes	Yes	Yes	Yes	Yes	Yes
Out Of Specification	Yes	Yes	Yes	Yes	Yes	Yes
Function Check	Yes	Yes	Yes	Yes	Yes	Yes
Device Configuration Locked	Yes	Yes	Yes	Yes	Yes	Yes
Electronic Defect	Yes	Yes	Yes	Yes	Yes	Yes
Power Supply Condition Out of Range	Yes	Yes	Yes	Yes	Yes	Yes
Non Volatile Memory Defect	Yes	Yes	Yes	Yes	Yes	Yes

- **Actuator Fail Alarm** - This alarm generates due to failure in internal self-test of the actuator.
- **Power Monitor Alarm** - This alarm indicates a device failure due to loss of control voltage internal to the actuator (control voltage is associated with either fuze F1 or F2).
- **Motor Thermal Alarm** - This alarm indicates a device failure because the motor control circuit is disabled due to motor overheating or motor overload relay (if equipped) has tripped.
- **Phase Monitor Alarm** - This alarm indicates a device failure because the optional phase monitor, if installed, indicates a loss of one-phase or reversed-phase rotation of incoming three-phase power.
- **Moving Wrong Direction** - This alarm indicates that the actuator was turning in the wrong direction.
- **Communication Failed Alarm** - This alarm indicates a device failure because communication between the HART Interface and actuator has failed or has an error due to data integrity.
- **Electronic Failure Alarm** - This alarm indicates the internal hardwired system failure of electronics.

- **Initialization Failed Alarm**- This alarm indicates the HART cannot communicate with the actuator or the upload/download generates an error.
- **Compatibility Error Alarm** – This alarm indicates the Actuator model or the Firmware is not compatible with the HART CAM board.
- **Over Pressure in Mid Travel Alarm** - This alert indicates that the hydraulic pressure has exceeded the archived pressure value and Pressure value Tolerance level (%) in the open direction.
- **Analog Input Out of Range Alarm** - This alarm indicates that the analog input to the actuator is beyond the legal limits of the input channel.
- **Overshoot Alarm** - This condition is reported when the valve crossed the target port and the valve must go all the way around. After 3 retries, this alarm will be triggered indicating a maintenance issue.
- **Stop Between Ports Alarm** - This alarm indicates that the actuator has failed to move to the commanded port.
- **CPU Reset Alarm** - This alarm indicates that the CPU has reset due to the power cycle. Additionally, for TEC2 and EHO actuators, this alarm also indicates a request to restart the processor from host has been executed successfully.

---

**NOTE:**

Values of Duty Cycle, Default Setpoint 2 and Analog Output 1 Source are not retained after power cycling. They will go back to the default value when actuator power is restored.

---

- **Valve Drift Alarm** - This Alarm indicates that the movement that has been detected was not initiated from the motor running.
- **Low Battery Alarm** - This Alarm indicates that the actuator has detected a low charge voltage on the internal Super CAP/Battery.
- **Limits Not Set Alarm** - This alarm indicates that the Fully Open and Fully Close limits are not configured.
- **Low Oil Level Alarm** - This alarm indicates oil level in hydraulic tank is less. However, this alert does not prevent actuator operation. This Alarm is only for EHO.
- **Inhibit Alarm** - This alarm indicates that the actuator has been configured to use the discrete inputs as inhibits and one of them is currently active. When active, this alarm will inhibit Actuator from moving.
- **CCM Failure Alarm** - This alarm indicates that Central Control Module has detected an internal failure.
- **LDM Failure Alarm** - This alarm indicates that Local Display Module has detected an internal failure.
- **APD Failure Alarm** - This alarm indicates Absolute Position Detector failure.
- **RDM1 Failure Alarm** - This alarm indicates Remote Display 1 failure. Remote display has been enabled in the configuration and either the RDM is not present, or has communication errors.
- **RDM2 Failure Alarm** - This alarm indicates Remote Display 2 failure. Remote display has been enabled in the configuration and either the RDM is not present, or has communication errors.
- **Hydraulic Power Unit Fault Alarm** - The alarm indicates the Hydraulic Power unit Failure. Triggered when the Motor ran for more than 4 seconds but hydraulic pressure has not increased.

- **Solenoid Valve Fault Alarm** - This alarm indicates SOV failure.
  - **Pressure Transmitter Fault Alarm** - The alarm indicates pressure transmitter failure.
  - **Encoder Fault Alarm** - Encoder alarm indicates the position value is incorrect due to communication error in encoder circuit.
  - **Close Torque Switch Alarm** - The alarm indicates that close torque limit has exceeded its value the last time the actuator attempted to move in the close direction.
  - **Open Torque Switch Alarm** - The alarm indicates that open torque has exceeded the configured value in the open direction.
  - **Over Torque Switch Alarm** - The alarm indicates that torque has exceeded the torque limit.
  - **Config Conflict Error Alarm** - The alarm indicates that actuator has been incorrectly configured, or hardware sanity checks do not match the actuator configuration settings. Internal system corruption of Control board may occur.
  - **Invalid SOV configuration Alarm** - This alarm indicates SOV configuration is incorrect during self-calibration.
  - **Accumulator Pre Charge Alarm** - This alarm indicates that the accumulator nitrogen pre-charge is not within the set range.
  - **Accumulator Charge Fault Alarm** - This alarm indicates that the accumulator did not charge to the maximum pressure within the allowed charge time. The electric motor has been stopped until another command is received.
  - **Lost COM1 Alarm** - This alarm indicates that the Network Communications has failed.
  - **Lost COM2 Alarm** - This alarm indicates that the Network Communications has failed.
  - **ESD from Lost COM** - This alarm indicates that actuator has been configured to perform ESD action on Lost COM alarm and the alarm is active.
- 

**NOTE:**

Loss in communication on HART side does not disturb the communication on Modbus side as HART CAM card is integral part of actuator, hence this alarm will not be generated unless CAM card is removed from actuator.

---

- **Hardwired ESD Alarm** - This alarm indicates that actuator has been configured to perform ESD action on Lost COM alarm and the alarm is active.
- **Host Command ESD** - This alarm indicates that the HOST has sent an ESD command to the actuator.
- **Lost Analog Input 1 Alarm** - This alarm is triggered when the Analog Input 1 signal is not present and the actuator is configured for analog control.
- **Lost Analog Input 2 Alarm** - This alarm is triggered when the Analog Input 2 signal is not present and the actuator is configured for analog control.
- **Backup Power Alarm** - This alarm indicates that the actuator has detected a low charge voltage on the internal Super CAP.
- **Valve Stall Alarm** - This alarm indicates that the actuator has stalled for more than 10 seconds while moving to the commanded position.
- **Partial Stroke Test Fail Alarm** - This alarm is reported when the Partial Stroke Test was not successful.

## Section 6: Device Variables

### 6.1 Device Variables

This Field Device has nine (9) Device Variables. These variables can be selected against the HART primary variables: PV, SV, TV, and QV with some limitations.

**Table 25. Device Variables Table**

Device Variable Code	Device Variable Name	Units
0	Setpoint	%
1	Position	%
2	Torque	%
3	Analog Input 1	%
4	Analog Input 2	%
5	Analog Output 1	%
6	Analog Output 2	%
7	Hydraulic Pressure	PSI (Pounds Per Square Inch)
8	Accumulator Pressure	PSI (Pounds Per Square Inch)

### 6.2 Dynamic Variables

**Table 26. Dynamic Variables Table**

Sr. No.	Dynamic Variable	Default Assignment	Valid Range
1	Primary Variable	0: Setpoint	0: Setpoint
2	Secondary Variable	1: Position	0: Setpoint 1: Position
3	Tertiary Variable	2: Torque	2: Torque 3: Analog Input 1 4: Analog Input 2 5: Analog Output 1 6: Analog Output 2 7: Hydraulic Pressure 8: Accumulator Pressure
4	Quaternary Variable	3: Analog Input 1	2: Torque 3: Analog Input 1 4: Analog Input 2 5: Analog Output 1 6: Analog Output 2 7: Hydraulic Pressure 8: Accumulator Pressure

# Section 7: Status Information

## 7.1 Device Status

Bit 7 (“Device Malfunction”): This bit shall be set when any status Bit mapped to NE107 Category: Failure is set.

Bit 4 (“More Status Available”): This bit shall be set whenever any bit in the Additional Device Status Bytes is set, in other words, whenever any additional status information is available. Command #48 would be used to read the Additional Status Info.

## 7.2 Additional Device Status

Command #48 returns 10 bytes of data, with the following status:

**Table 27. Device Status Alarms (1)**

Byte	Bit	Meaning
0	7 (0x80)	APD Failure Alarm
	6 (0x40)	LDM Failure Alarm
	5 (0x20)	CCM Failure Alarm
	4 (0x10)	Moving Wrong Direction
	3 (0x08)	Power Monitor Alarm
	2 (0x04)	Motor Thermal Alarm
	1 (0x02)	Phase Monitor Alarm
	0 (0x01)	Actuator Fail Alarm
1	7 (0x80)	Electronic Failure
	6 (0x40)	Communication Failed Alarm
	5 (0x20)	Encoder Fault Alarm
	4 (0x10)	Pressure Transmitter Fault Alarm
	3 (0x08)	Solenoid Valve Fault Alarm
	2 (0x04)	Hydraulic Power Unit Fault Alarm
	1 (0x02)	RDM2 Failure Alarm
	0 (0x01)	RDM1 Failure Alarm
2	7 (0x80)	Overshoot Alarm1
	6 (0x40)	Over Torque
	5 (0x20)	Open Torque
	4 (0x10)	Close Torque
	3 (0x08)	AI-2 Out of Range.
	2 (0x04)	AI-1 Out of Range
	1 (0x02)	Over Pressure in Mid Travel Alarm.
	0 (0x01)	Initialization Failed Alarm
3	7 (0x80)	Accumulator Pre-Charge Alarm
	6 (0x40)	Limits Not Set Alarm
	5 (0x20)	Low Battery Alarm
	4 (0x10)	Valve Drift Alarm
	3 (0x08)	Invalid SOV configuration Alarm
	2 (0x04)	Config Conflict Error
	1 (0x02)	CPU Has Reset
	0 (0x01)	Stop Between Ports Alarm1

**Table 28. Device Status Alarms (2)**

Byte	Bit	Meaning
4	7 (0x80)	Reserved for Future Use
	6 (0x40)	Lost COM2 Alarm
	5 (0x20)	Lost COM1 Alarm
	4 (0x10)	Open Inhibit Alarm
	3 (0x08)	Close Inhibit Alarm
	2 (0x04)	Low Oil Level Alarm
	1 (0x02)	Accumulator Charge Fault Alarm
	0 (0x01)	Compatibility Error
5	7 (0x80)	Partial Stroke Test Fail Alarm
	6 (0x40)	Valve Stall Alarm
	5 (0x20)	Backup Power Alarm
	4 (0x10)	Lost Analog Input 2
	3 (0x08)	Lost Analog Input 1
	2 (0x04)	Host Command ESD
	1 (0x02)	Hardwired ESD Alarm
	0 (0x01)	Reserved for future use
6	7 (0x80)	Not used
	6 (0x40)	Not used
	5 (0x20)	Function Check
	4 (0x10)	Out Of Specification
	3 (0x08)	Failure
	2 (0x04)	Not Applicable
	1 (0x02)	Device Variable
	0 (0x01)	Maintenance Required
7	0 – 7	Operating Mode
8	7 (0x80)	Device Configuration Locked
	6 (0x40)	Electronic Defect
	5 (0x20)	Not Applicable
	4 (0x10)	Power Supply Conditions Out-of-Range
	3 (0x08)	Not Applicable
	2 (0x04)	Not Applicable
	1 (0x02)	Non-volatile Memory Defect
	0 (0x01)	Not Applicable
9	7 (0x80)	Not used
	6 (0x40)	Not used
	5 (0x20)	Not used
	4 (0x10)	Not used
	3 (0x08)	Not used
	2 (0x04)	Not Applicable
	1 (0x02)	Not Applicable
	0 (0x01)	Status Simulation Active

# Section 8: HART Commands Definition

## 8.1 Universal Commands

Device supports following Universal Commands –

**Table 29. Universal Commands Table**

Command	Description
0	Read Unique Identifier
1	Read Primary Variable
2	Read Loop Current And Percent Of Range
3	Read Dynamic Variables And Loop Current
6	Write Polling Address
7	Read Loop Configuration
8	Read Dynamic Variable Classifications
9	Read Device Variables with Status
11	Read Unique Identifier Associated With Tag
12	Read Message
13	Read Tag, Descriptor, Date
14	Read Primary Variable Transducer Information
15	Read Device Information
16	Read Final Assembly Number
17	Write Message
18	Write Tag, Descriptor, Date
19	Write Final Assembly Number
20	Read Long Tag
21	Read Unique Identifier Associated With Long Tag
22	Write Long Tag
38	Reset Configuration Changed Flag
48	Read Additional Device Status

Command #3 returns PV, SV, TV and QV for a total of 24 bytes of response data.

Command #48 returns 10 bytes of Additional Device Status.

## 8.2 Common Practice Commands

Device supports following Common Practice Commands –

**Table 30. Common Practice Commands Table**

Command	Description
33	Read Device Variable
34	Write Primary Variable Damping Value
42	Perform Device Reset
49	Write Primary Variable Transducer Serial Number
50	Read Dynamic Variable Assignments
51	Write Dynamic Variable Assignments
54	Read Device Variable Information
56	Write Device Variable Transducer Serial Number
59	Write Number of Response Preambles
71	Lock Device
72	Squawk
76	Read Lock Device State
89	Set Real-Time Clock
90	Read Real-Time Clock
95	Read Device Communications Statistics
103	Write Burst Period
104	Write Burst Trigger
105	Read Burst Mode Configuration
107	Write Burst Device Variable
108	Write Burst Mode Command Number
109	Burst Mode Control
523	Read Condensed Status Mapping Array
524	Write Condensed Status Mapping
525	Reset Condensed Status Map
526	Write Status Simulation Mode
527	Simulation Status Bit

## 8.3 Device Specific Commands

Table 31. Device Specific Commands Table (1)

Command	Description
129	Default User NV Parameters
130	Write Device Variable (MANUAL)
131	Enable Write Protect Mode
132	Enable/Disable S/W Simulation of Alarms
133	Write ESD Delay
134	Write Valve Stall Delay Time
135	Enable/Disable PST
136	Write Analog Control Source
137	Write Maximum Torque
138	Write Stroke Time
139	Write Language Selection
140	Enable/Disable Accumulator
141	Configure Valve Control Mode
142	Write Maximum Hydraulic Circuit Pressure
143	Write Maximum Self Calibration Pressure
144	Write Self Calibration Stroke Count Range
145	Write Pressure Unit
146	Write Control Mode
147	Enable/Disable RDMs
148	Write Control Parameter 1
149	Write Control Parameter 2
150	Write Modulation Parameters
151	Configure Analog Input Alarms
152	Write Actuator Command (MANUAL)
153	Write Host Command ESD (MANUAL)
154	Enter Into Setup Mode
155	Write Limit Switch Trigger Point
156	Write Discrete Input Configuration
157	Write Relay Configuration
158	Write Open Speed Control Parameters
159	Write Custom Characterization Type
160	Write Target Travel ( Indices [0] – [49] )
161	Write Port Information
162	Enable/Disable ESD and Configure Action
163	Write ESD Overrides Parameter
164	Write Default Setpoints
165	Write Bluetooth Parameters
167	Write Configuration Commands
168	Write Torque Limits
169	Write MPA Port Calibration Data
171	Read Software Version ID
172	Read Compatibility Number
173	Read Alarms Simulation (Software) Status

**Table 32. Device Specific Commands Table (2)**

Command	Description
174	Read Field Diagnostic Code
175	Read Alarm – Torque Out of Range
176	Read ESD Delay
177	Read Valve Stall Delay Time
178	Read PST Status
179	Read Analog Control Source
180	Read Maximum Torque
181	Read Stroke Time
182	Read Language Selection
183	Read Prognostics
184	Read Accumulator Status
185	Read Self Calibration Status
186	Read Maximum Hydraulic Circuit Pressure
187	Read Maximum Self Calibration Pressure
188	Read Self Calibration Stroke Count Range
189	Read Actuator Fully Open Time
190	Read Actuator Fully Close Time
191	Read Pressure Unit
192	Read Control Mode
193	Read RDM status
194	Read Control Parameter 1
195	Read Control Parameter 2
196	Read Modulation Parameters
197	Read Analog Parameters
198	Read Factory Hardware Parameters
199	Exit from Setup Mode
200	Read Actuator Command Status
201	Read Host Command ESD Status
202	Read HART Function Type
203	Read Actuator Mode
204	Read Firmware Date
205	Read Limit Switch Status
206	Read Limit Switch Trigger Points
207	Read Discrete Input Status
208	Read Discrete Input Configuration
209	Read Relay Status
210	Read Relay Configuration
211	Read Speed Control Parameter
212	Read Open Torque Profile ( Indices [0] – [50] )
213	Read Open Torque Profile ( Indices [51] – [100] )
214	Read Close Torque Profile ( Indices [0] – [50] )
215	Read Close Torque Profile ( Indices [51] – [100] )
216	Read Firmware Revision Numbers
217	Read Custom Characterization Type
218	Read Target Travel ( Indices [0] – [49] )
219	Read Port Information
220	Read ESD Parameters

**Table 33. Device Specific Commands Table (3)**

Command	Description
221	Read ESD status and Action
222	Read ESD Overrides Parameter
223	Read PST Parameter
224	Read Operations Log
225	Read Default Setpoints
226	Read Bluetooth Parameters
227	Read Valve Control Mode
228	Read Factory Software Details
229	Read Torque Limits
230	Read MPA Port Calibration Data
231	Write Target Travel ( Indices [50] – [99] )
232	Enable / Disable Speed Control
233	Write Analog Output 1 Source
234	Write Analog Output 2 Source
235	Write Tag Information
236	Write Device Variable (AUTO)
237	Write Actuator Command (AUTO)
238	Host ESD / Clear ESD (AUTO)
239	Write Relay status (AUTO)
240	Write Relay status (MANUAL)
241	Read Model Number Details
242	Read Archived Open Torque Profile ( Indices [0] – [50] )
243	Read Archived Open Torque Profile ( Indices [51] – [100] )
244	Read Archived Close Torque Profile ( Indices [0] – [50] )
245	Read Archived Close Torque Profile ( Indices [51] – [100] )
246	Read Target Travel ( Indices [50] – [99] )
247	Write Close Speed Control Parameters
248	Write Anti Water Hammer Speed Control Parameters
249	Read Device Variables' Alarm Control Code
250	Write Device Variables' Alarm Control Code
251	Enable Disable CPU Reset Alarm Control Code
252	Read CPU Reset Alarm Control Code

## Section 9: Device Descriptor (DD)

**NOTE:**

To download the DD for non-Emerson 3rd party host, please refer to the HART Foundation website: <http://en.hartcomm.org/> and navigate to the Product Catalog.

To download the DD for Emerson hosts, please refer to: <http://www.emersonprocess.com> and do a search for “device install kit”, then follow the steps.

### 9.1 Procedure for Adding DD to AMS and 375/475

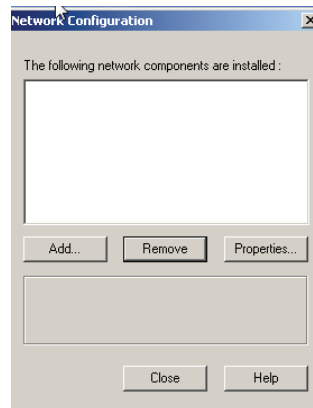
**Steps for installing stand-alone AMS:**

Before we add DD to AMS, we need to configure HART Modem on AMS. (Ensure that HART Modem drivers are already installed before configuring Modems on AMS). Follow steps as stated below:

**Network Configuration:**

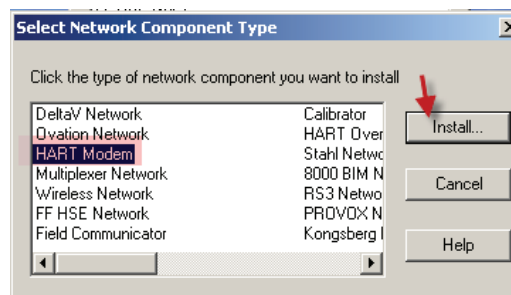
1. Open Start> All Programs> AMS Device Manager> Network Configuration

**Figure 35 Network Configuration Window**



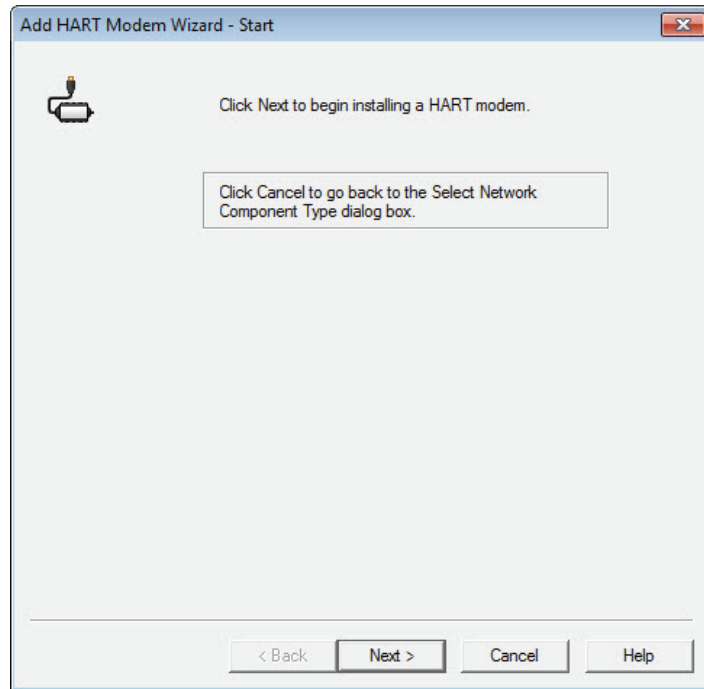
2. Click on Add and select Network Component Type:  
For HART device: HART Modem

**Figure 36 Select Network Component Type**

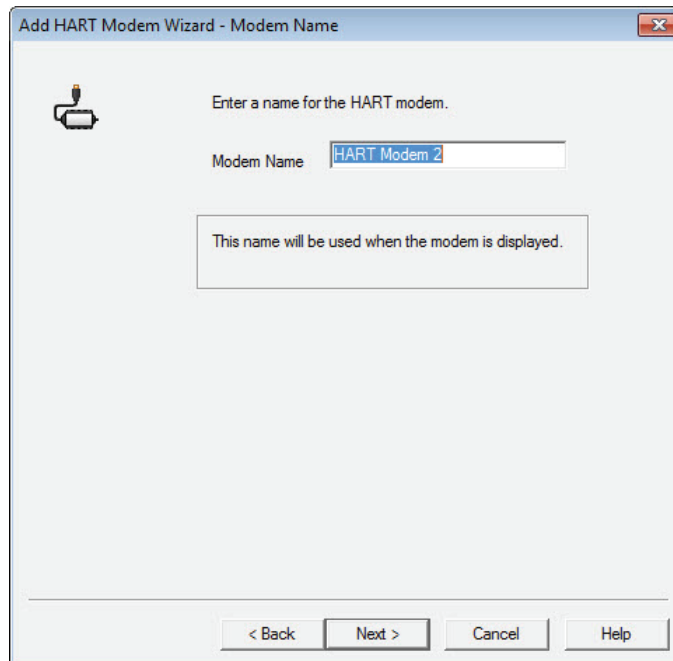


3. Click on Install and follow screen instructions.

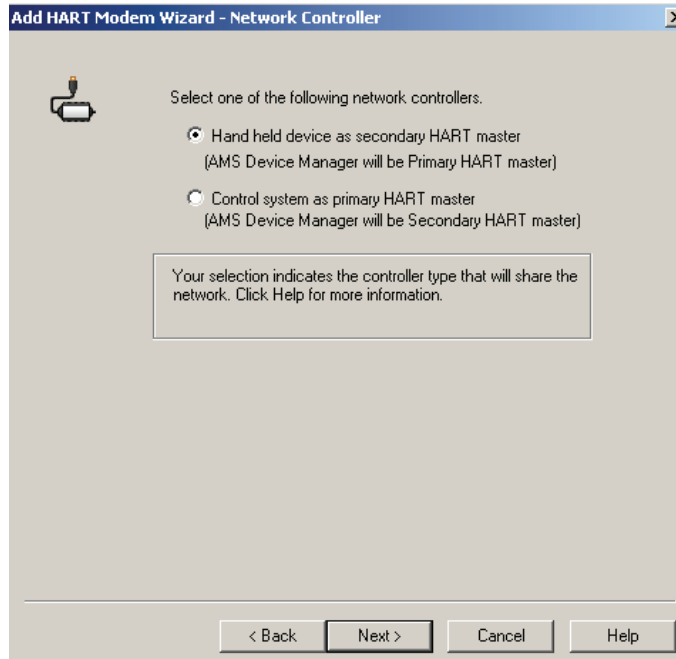
**Figure 37 Adding the HART Modem (1)**



**Figure 38 Adding the HART Modem (2)**



**Figure 39 Adding the HART Modem (3)**



4. Select one COM Port from the list.

**Figure 40 Adding the HART Modem (4)**

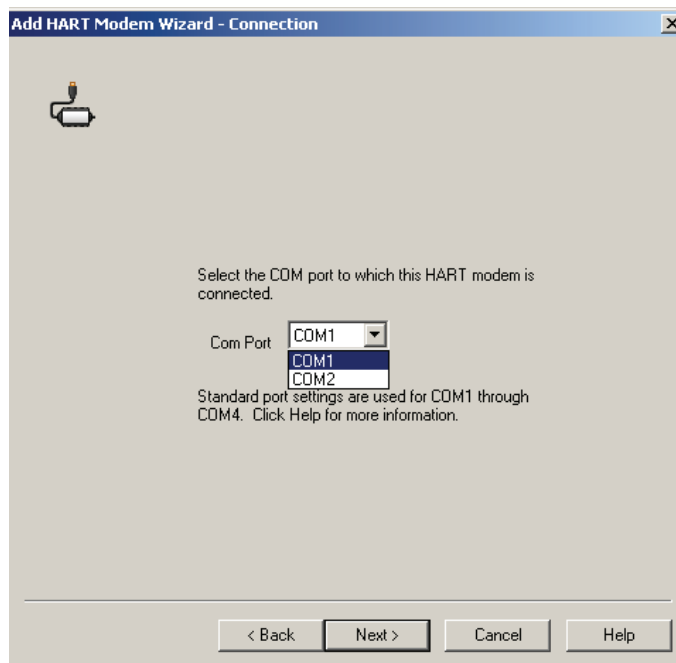
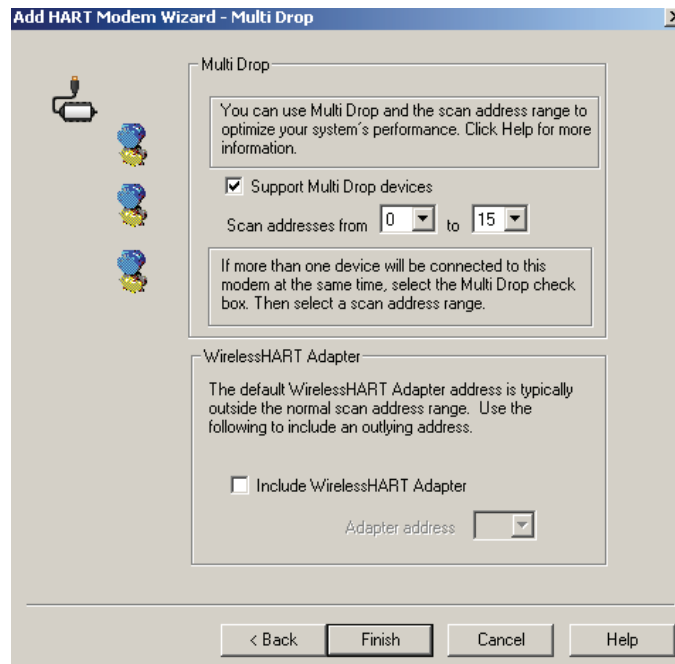
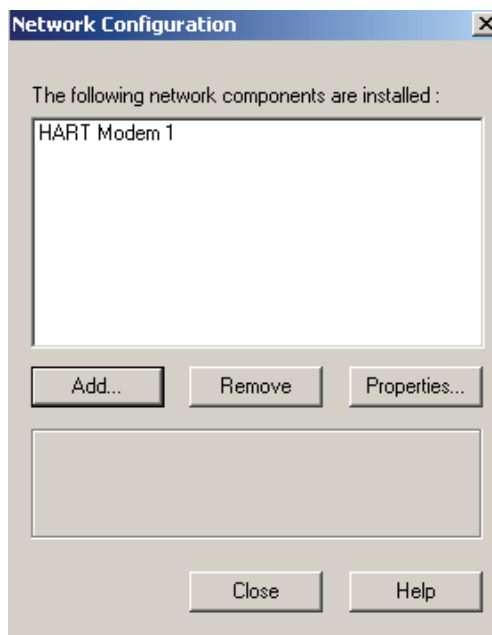


Figure 41 Adding the HART Modem (5)



When it is finished you will see a HART Modem added into the Network Configuration screen.

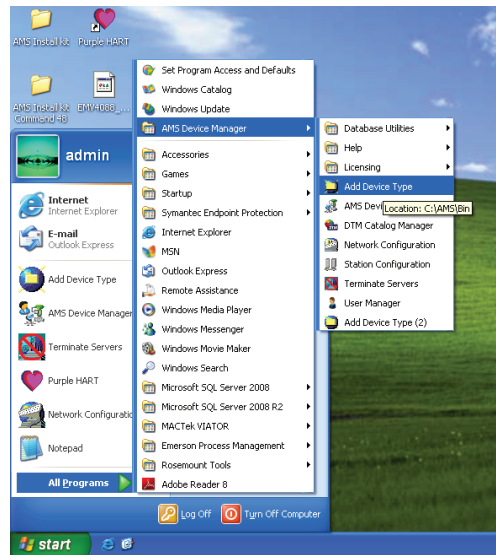
Figure 42 HART Modem 1 Now Added



### Adding a new Device Descriptor (DD) in AMS:

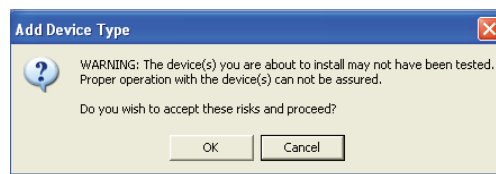
1. Click on the start button and follow the sequence as shown below to open the Add Device Type Program in AMS Device Manager:  
Navigate to All programs -> AMS Device Manager -> Add device type

Figure 43 Starting the AMS



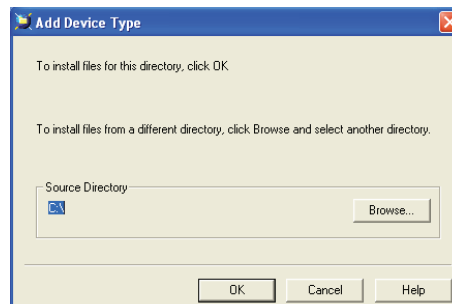
2. A warning message will appear on the screen, click the option “OK” on the generated window.

Figure 44 Add Device Type



3. Click the option “Browse” as shown below and go to the location of the install kit.

Figure 45 Browsing for Installation Folder



Click OK and the DD will install. A progress bar will show for some period of time.

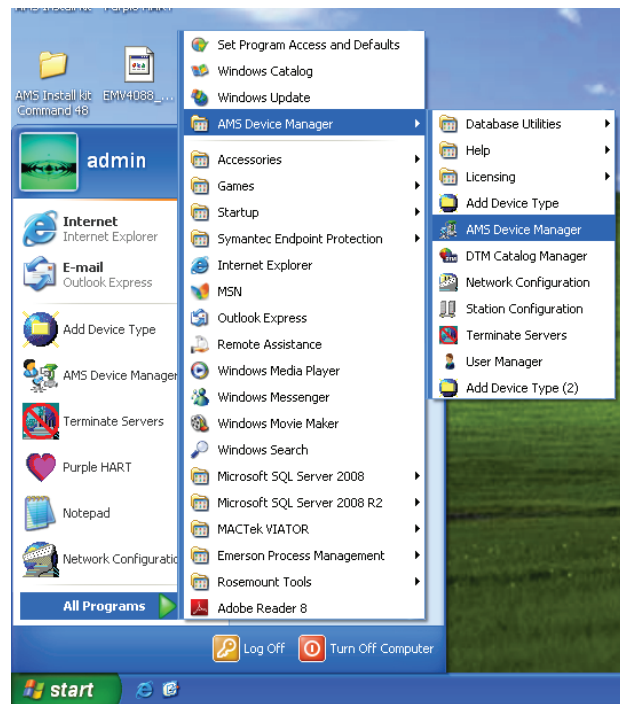
4. When it is finished a message will pop up letting you know if DD is installed successfully or not.

**Figure 46 DD Installation Complete**



5. To start the AMS process, click on the Start button and follow the sequence as shown below:  
Navigate to All Programs -> AMS Device Manager -> AMS Device Manager

**Figure 47 Starting AMS**



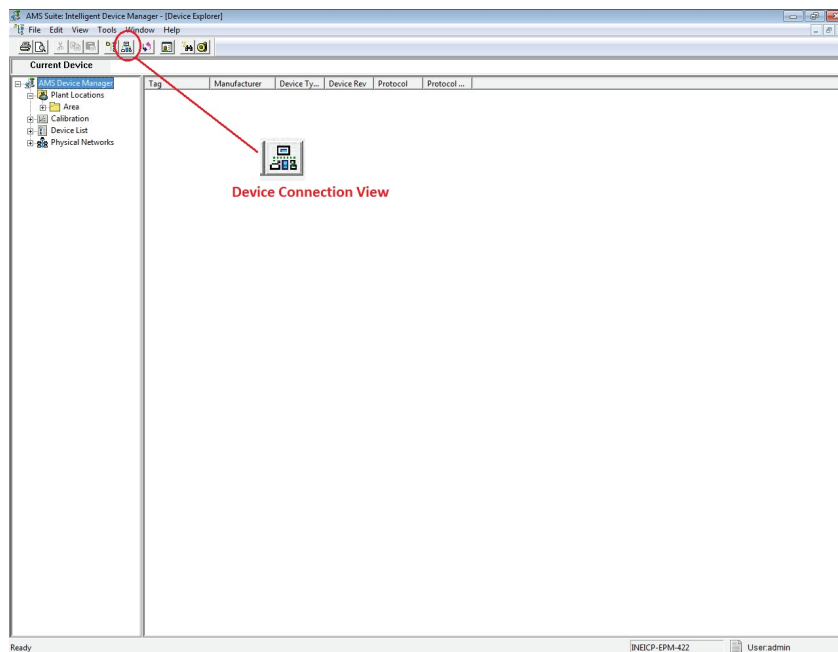
6. Fill the user name as shown below. Password field will be left blank and Press OK.

Figure 48 User Name Window



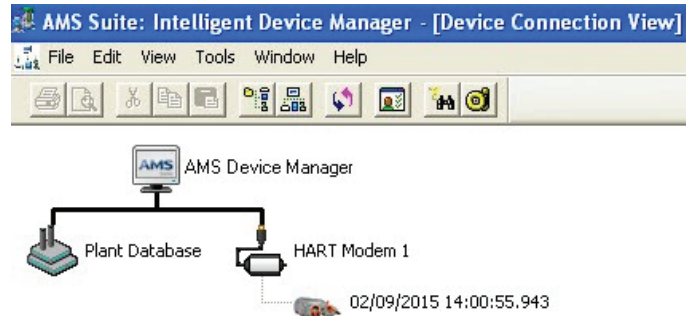
7. Once the Login process is complete, the Device Explorer Screen will appear. On the Device Explorer Screen, Click on Device Connection View.

Figure 49 Device Explorer Window



8. Here, the Device will detect under HART Modem Tab as shown in below image:

**Figure 50 AMS Device Manager Detection**



#### Troubleshooting AMS:

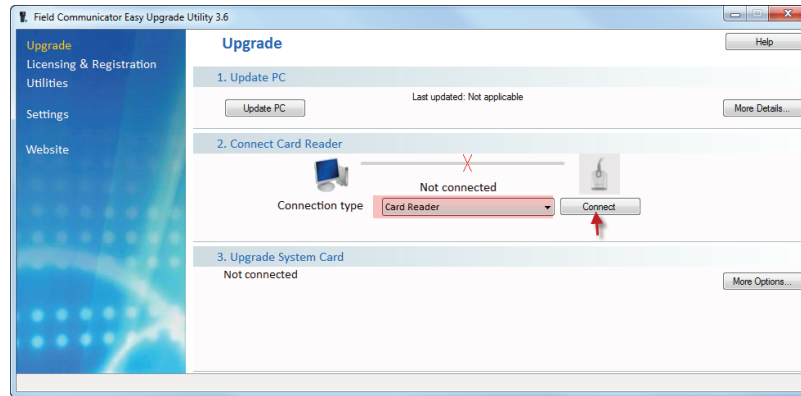
1. If AMS Device Manager does not show the live device on Device Connection View, Under the HART Modem Tab, then do the following:
  - Use the AMS Device Manager Configuration program to ensure that the modem has been assigned to a COM port.
  - Check that the modem is connected to the serial port corresponding to the COM port.
2. If AMS Device Manager gives error messages when it tries to populate the database with the new device, do the following: Run the AMS Device Manager Database Verify/ Repair (Start-All Programs- AMS Device Manager- Database Utilities-Database Verify Repair).
3. If New DD is added in AMS and it shows the old DD. First remove old DD available in database i.e. from C:\AMS\Devices\HART\06060, and then add new DD to AMS through add Device Type.

#### Adding a DD to the 375/475 (HandHeld)

1. Prerequisites:
  - 375/475
  - DD Files
  - SD Card Reader
  - Field Communicator Easy Upgrade Utility
2. DD will be added using the Easy Upgrade Programming Utility (in Start Menu)
3. Open Easy Upgrade Utility
4. 375/475 can be connected to PC via IrDA, Bluetooth and Card Reader

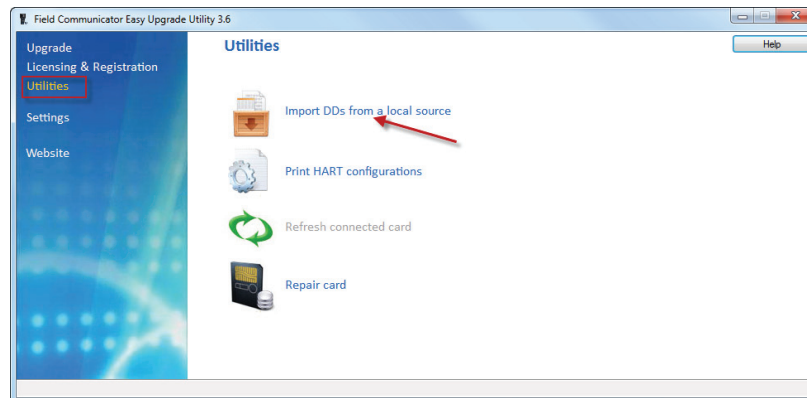
5. Select the connection type “Card Reader” and click connect.

**Figure 51** Connecting to the Card Reader



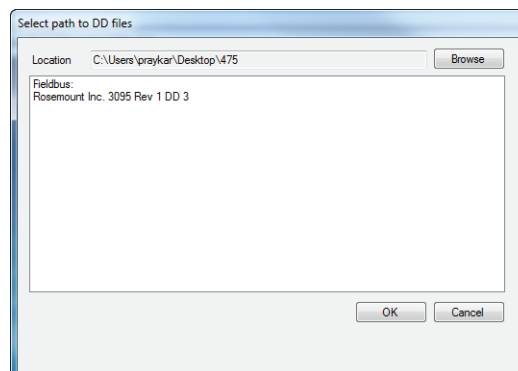
6. After a successful connection, in the left hand menu, click on Utilities and Select Import DDs from Local source.

**Figure 52** Selecting DDs from Local Source



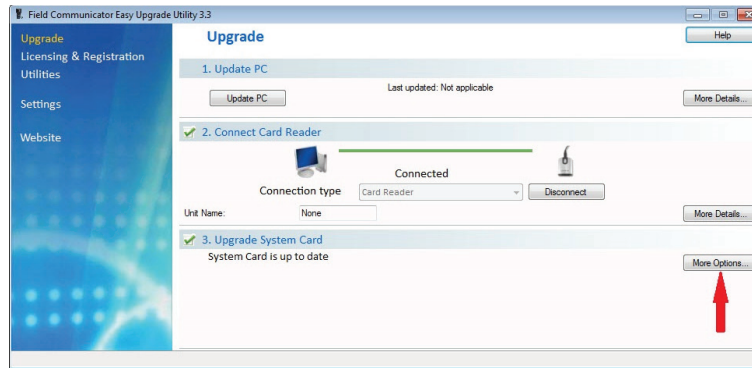
7. Browse to where the 375/475 files (.hdd and .hhd) are located and click OK. You will get a message saying the import was successful.

**Figure 53** Browsing for the Files

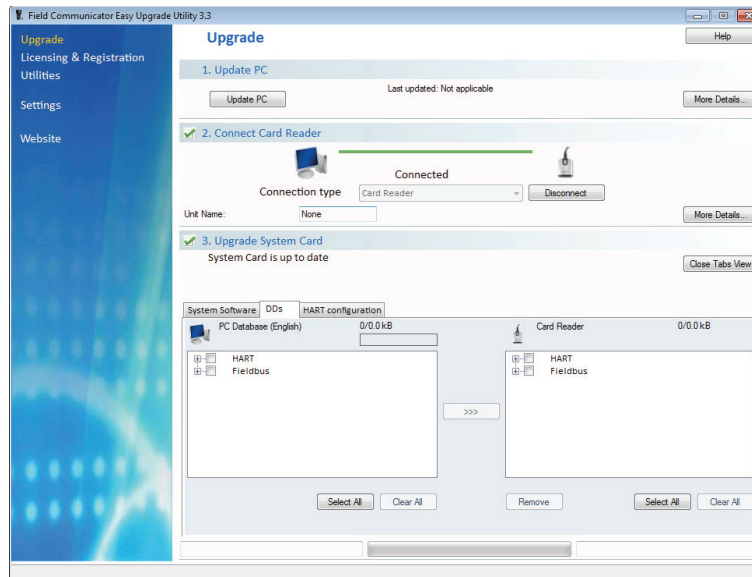


8. Now you have imported DD in your PC database.
9. Next step is to add this DD in your Card Reader.
10. Click on Upgrade and “More Options” in Upgrade System Card.

**Figure 54** Accessing More Options

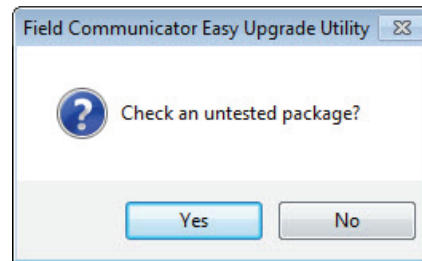


**Figure 55** Options Window



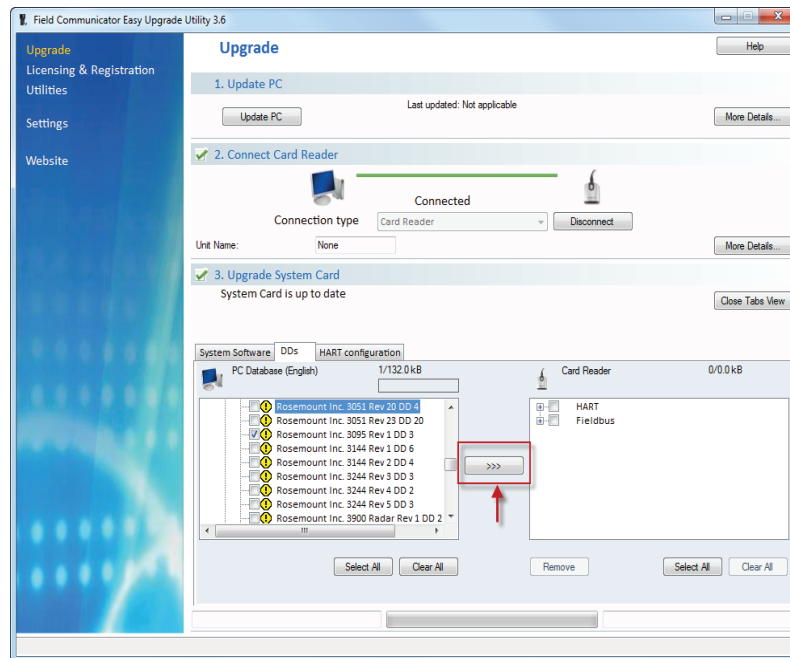
11. The name of the DD and its details will be seen on DDs Tab. Expand HART database. Check the DD, you will get a pop message about the untested package is being created, click on “Yes”.

**Figure 56** Untested Package Checking



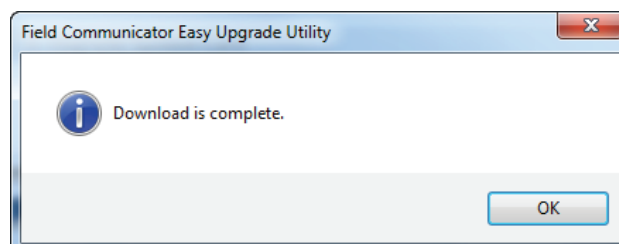
12. Click on “Yes”, this will activate the button.

**Figure 57** Adding the Selected Item



13. Click on the button below, this will add DD to card reader and give a message; “Download is complete”.

**Figure 58** Completion Message



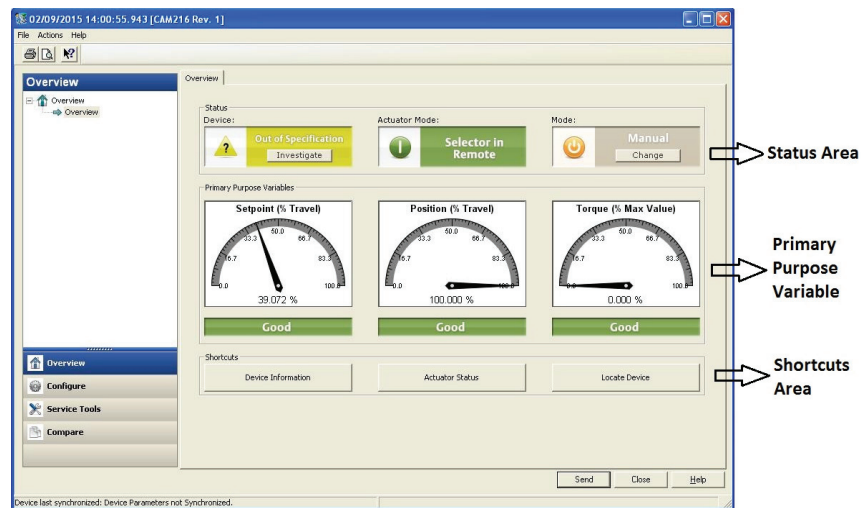
14. Now your DD is ready for use.

## 9.2 Overview Screen

Double-click the device icon; the AMS Device Manager, Window will open with the Overview menu displayed. The Overview screen contains three areas:

- The Status area
- The Primary Purpose Variables (or Variable)
- The Shortcuts area

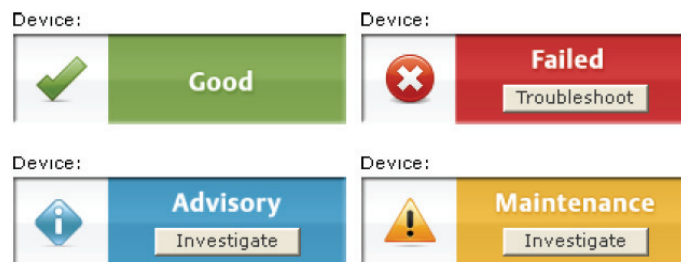
Figure 59 Overview Screen



## 9.3 Device Status Images

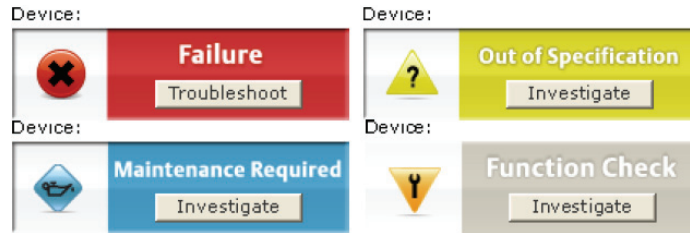
- PlantWeb alerts

Figure 60 PlantWeb Alert Displays



- NAMUR NE107 based alerts

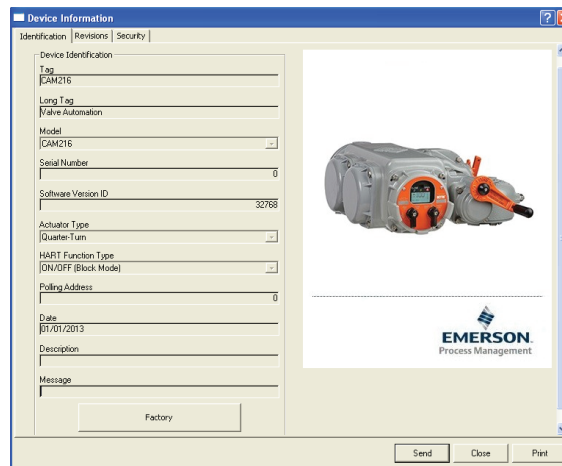
**Figure 61 NAMUR Alert Displays**



## 9.4 Device Information

To get the device information details, click on “Device Information” button (Overview Screen -> Device Information). Device Information Screen can be seen as follows:

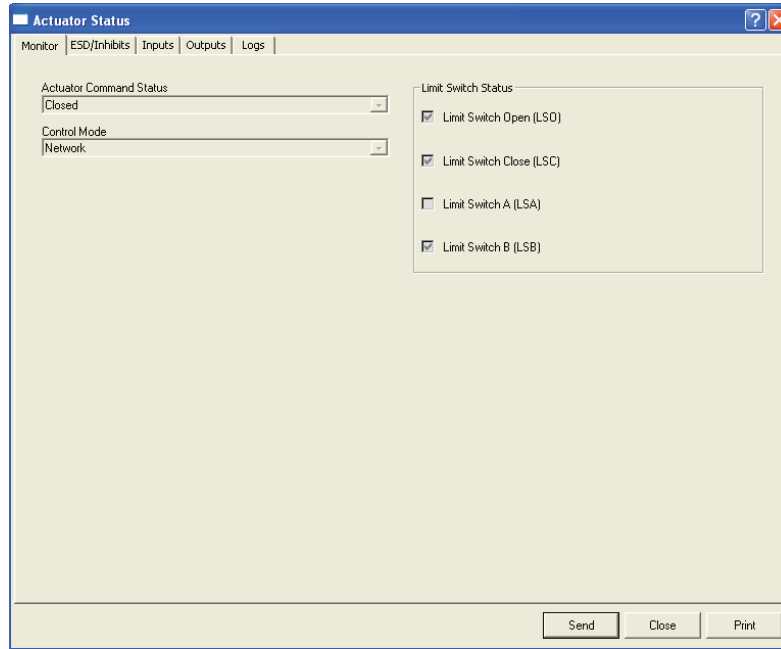
**Figure 62 Device Information Window**



## 9.5 Actuator Status

To get Actuator Information details click on “Actuator Status” button (Overview Screen -> Actuator Status). Actuator Status Screen can be seen as follows:

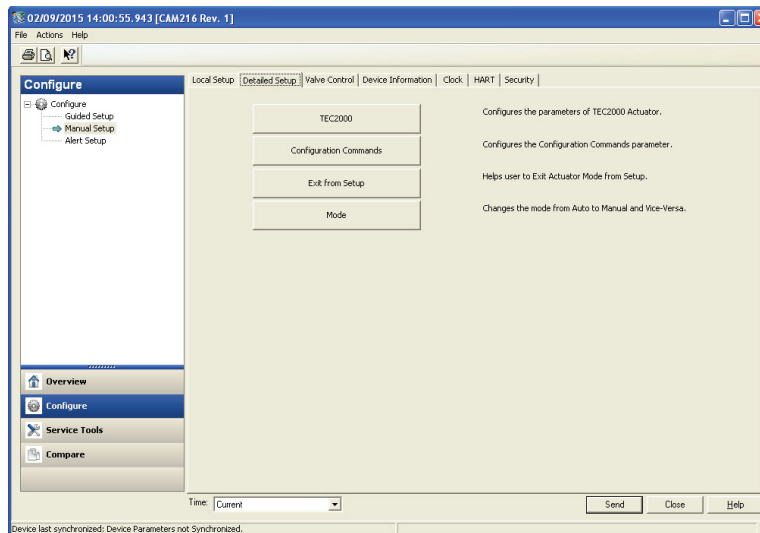
Figure 63 Actuator Status Window



## 9.6 Manual Setup

Manual Setup is used for configuring the device on a parameter basis.

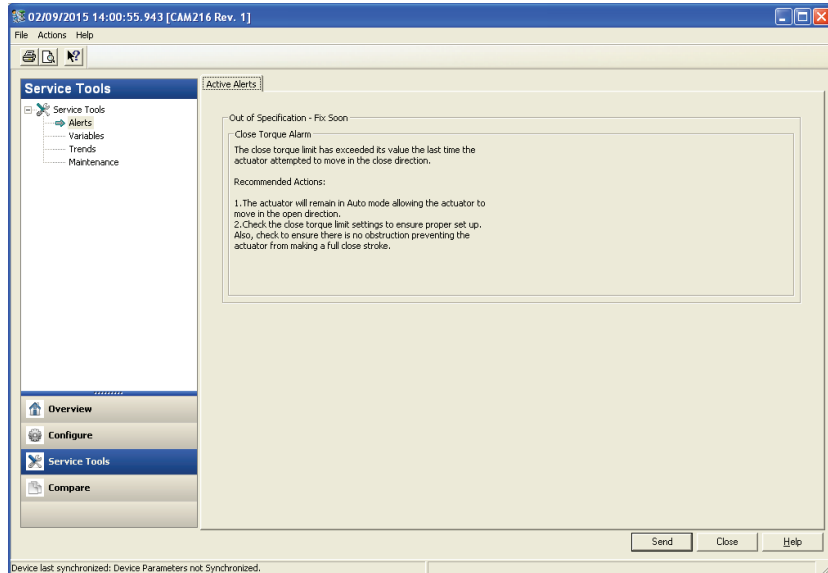
Figure 64 Manual Setup Window



## 9.7 Service Tools

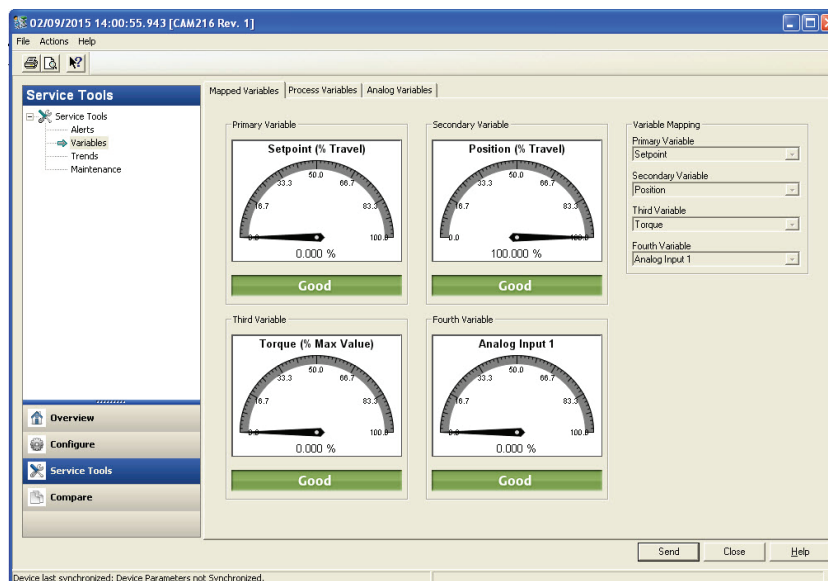
- Alerts**  
This page will contain the active alerts  
If no alerts are active, then “No Active Alerts” image will be displayed.

Figure 65 Active Alerts Window



- Variables**  
This section contains all the measurements or calculated values a device is capable of displaying throughout the user interface.

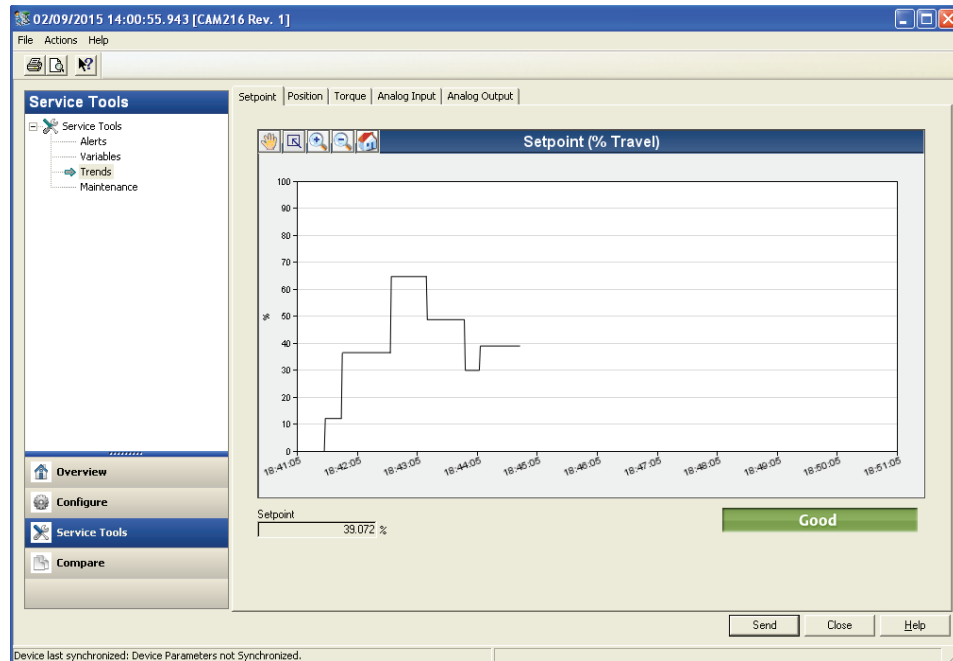
Figure 66 Variables Window



3. Trends

This menu displays the charts and graphs with charts updating in real time.

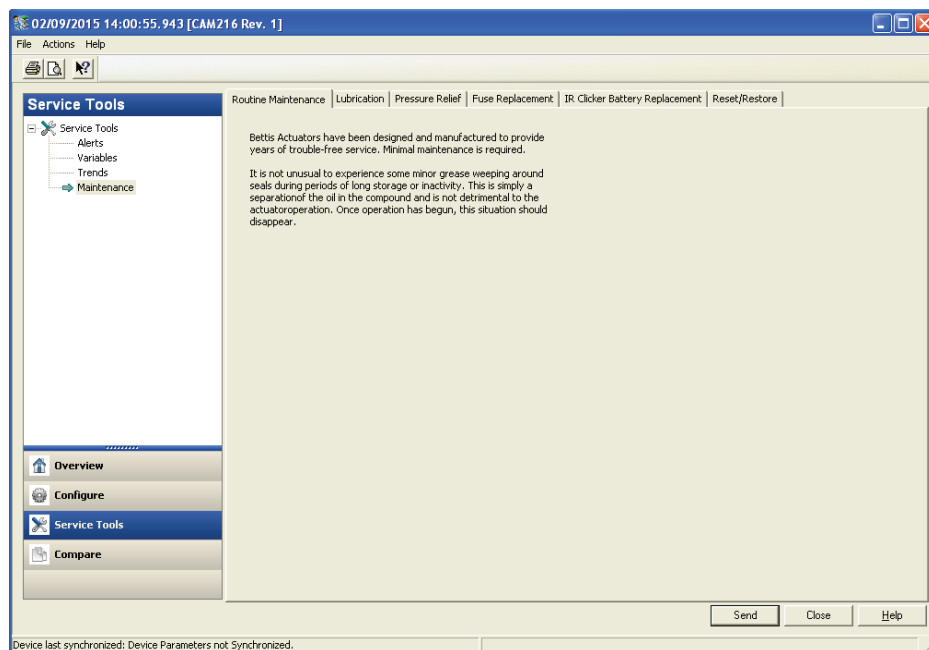
Figure 67 Trends Window



4. Maintenance

This menu is used for common maintenance tasks.

Figure 68 Maintenance Tasks Window



## 9.8 Methods

Methods, as used in HART terms, are a predetermined sequence of steps. These steps usually use a structured programming language and an interface definition. Methods can be used for a variety of functions including changing the mode and configuring the actuator. The hosting system and configuration software determines how these methods are handled and appear to the user.

Emerson Process Management electric actuators using HART CAM16/216 provide the following methods:

- **Locate Device Method:**  
It is used to identify the device in the field by showing pattern (0-0-0) on the device display. This method is applicable to MPA, TEC2000, TEC2, Model 500, and EHO.
- **Change Mode Method:**  
It allows the User to change the mode from Auto to Manual and vice-versa.
- **Detailed Setup Method:**  
It is used to configure the parameters of particular actuator.
- **Target Travel Method:**  
It can be used to configure Custom Characterization data points.
- **Configuration Commands Method:**  
It is used to configure the Configuration Commands parameter. Configuration Commands parameter is reserved for internal use only.
- **Actuator Command Method:**  
It can be used to control the actuator. The device will accept an Open, Close or Stop command and react accordingly. In case of MPA this method is called as Go to Next Port. This method is used to change the port of MPA actuator.
- **Configure Polling Address Method:**  
It allows the User to change the polling address of the device.
- **Configure Advanced Broadcasting Method:**  
It is used to configure three Burst Messages. This method will work only with those hosts who support advanced broadcasting.
- **Write Protection Method:**  
It allows the user to prevent changes to the device's configuration.
- **Lock/Unlock Method:**  
It allows a Master to give exclusive access of Device. It gives basically three options to lock the Device, Temporarily, Permanent, and Lock All to prevent the configurations that can be changed by another master.
- **Configure Setpoint Method:**  
It allows the User to change the Setpoint of the device. This method is applicable only for MPA.
- **Device Reset Method:**  
It is used to reset the CAM card.

## Section 10: Miscellaneous

### 10.1 Stroking the Actuator

The actuator can be stroked (opened or closed) via the following techniques:

1. The hand wheel
2. The Local Push Buttons
3. Remotely using other Host, means such as Emerson's DCMLink software

#### 10.1.1 Using the Hand wheel (On/Off Function Type)

To use the hand wheel to stroke the actuator while the selector switch is in Remote/Auto position, the actuator must be commanded to its "Stop" state via the Actuator Command parameter. Normally, if the hand wheel is turned while the actuator is in control (Auto), and the movement causes the actuator to move more than the Deadband value from its commanded position, the actuator will compensate and attempt to move the actuator to its original commanded position, given that the Setpoint tracking option is selected. Using the "Stop" command will cause the actuator to stop processing position, thereby allowing the user to move the actuator with the hand wheel. Alternately, the LOR selector switch on the Local Control Panel can be moved to the "Local/Manual" or "OFF" position. The actuator electronics no longer has control of the actuator. It may then be moved using the Hand wheel.

---

#### NOTE:

If the selector switch is in the Remote/Auto position and the Actuator Command is changed from "Stop", the actuator will immediately start moving to the commanded position depending on the control source (see the following sections).

- 
1. Send a "Stop" command to the device Actuator Command parameter via the Discrete Output function block.
  2. Move the actuator with the hand wheel.
  3. Command the actuator to the desired position.

#### 10.1.2 Using the hand wheel (Positioning Function Type)

To use the hand wheel to stroke the positioning actuator, the LOR selector switch should be moved to the "Local/Manual" or "OFF" position. If the hand wheel is turned while the actuator is in control, and the movement causes the actuator to exceed its Deadband value, the actuator will compensate and attempt to position the actuator to the originally commanded position. Placing the selector switch in the "Local/Manual" or "OFF" position will remove control from the actuator thereby allowing the user to move the actuator with the hand wheel.

---

#### NOTE:

When the selector switch is moved to the "Remote/Auto" position, the actuator will immediately start moving the actuator to the commanded position depending on the control source (see the following sections).

---

#### 10.1.3 HART Interface Procedure

When in remote mode (Auto) and the actuator is in a normal state, use SV (Setpoint) to command the actuator at desired position (0 to 100%), as long as the actuator is in the network control mode.

If the actuator is in analog control mode, you must use the configured Analog Input designated for control, and supply a signal of 4mA (0%) to close and 20mA (100%) to open.

The M2CP actuator is not polarity sensitive for HART communications, but it is polarity sensitive for analog control purposes. Hence incorrect connection of the analog current cables will not allow a host to control the position of the actuator.

#### 10.1.4 Using the Local Control Station (if equipped)

This section provides information as to the status indications received from the actuator when the actuator is equipped with a Local Control Station.

When the Local Control Station is used, placing the LOR selector switch in the Local/Manual position on the control panel will cause the "Local Override" status in the Actuator Status parameter to become true.

---

#### NOTE:

The Local Control Station has priority over all control sources. When equipped and activated, no other control sources, including HART, can control the actuator until the Local Control Station selector switch is returned to the "Remote/Auto" position, returning control to the other "electronic" control means.

The Local Control Station has two sets of controls; 1) LOR selector switch with three (3) positions (Local/Manual, OFF, and Remote/Auto) and 2) Control push-buttons with three (3) buttons (Open, Stop, and Close).

---

Procedure is as follows –

- Change the LOR selector switch position (mode) to (L) "Local/Manual".
- Move the actuator to the desired position using the Open, Stop, or Closed push buttons.
- When the actuator has moved to the desired position, return control to the HART Interface by placing the LOR in "Remote/Auto" position.
- At this point, the actuator will travel to its commanded position as specified via the Setpoint or Actuator Command parameter.

#### 10.1.5 Using Other Remote Control Means

This section provides information on remote control of the actuator by means other than the HART Interface. The 320B controller within the actuator has two independent communication channels. One channel is used by the HART Interface and the other may be available to other configuration or remote control devices communicating on the other channel with another protocol. Such devices include Emerson's DCMLink, a PC Windows-based software package.

The 320B controller may also be configured to accept control from other means such as "discrete switch inputs" (pulse input mode) and "4-20mA control signal" (analog control mode). Refer to Emerson Process Management Electric Actuator Quick Startup Guide for wire connections and configuration setting of the 320B module.

When the actuator is configured to "Network" mode, it will be controlled by the digital command sent from the control system to the value of SV (set point), or when in block mode, to whichever open, close or stop command has been sent.

When the actuator is configured to "Analog Control" mode, the actuator will be controlled by the input connected to Analog Input 1 channel (4-20mA) to indicate 0-100% once it has been calibrated.

# Section 11: Installation of Optional THUM Wireless Adapter

## 11.1 Component Installation on TEC2000, TEC2 and Model 500

1. Disconnect the actuator from the power source and open the back cover to expose the STC.
2. Apply Teflon tape to both, the THUM and the reducer bushing threads to prevent galling.
3. Insert the Wireless HART THUM and a 3/4 to 1/4 conduit reducer into one of the access ports in the actuator control housing. Then, tighten securely, making sure not to damage wires while turning.

**NOTE:**

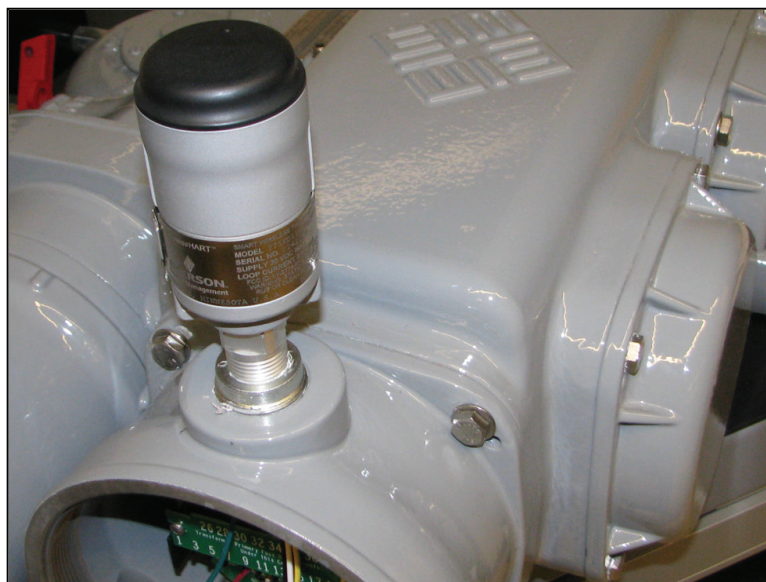
Reducer bushings used for non-hazardous locations installation only.

4. Once the THUM is securely installed, wire as shown below:

**Table 34. TEC2000 and THUM Wiring Configuration**

TEC2000 STC	THUM
9	Red
10	Black 1200 Ohm Series Resistor
24	Green (Optional)
43	Yellow
44	White

**Figure 69 THUM mounted on TEC2000**



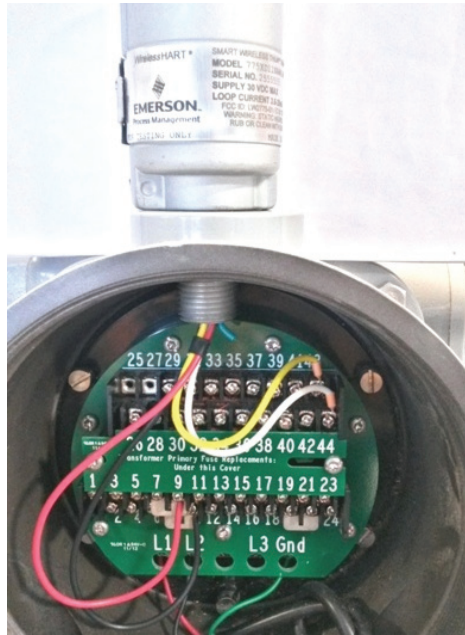
---

**NOTE:**

Resistors and other required parts are available by ordering Part No. 87263 “Wireless HART THUM Kit”.

---

**Figure 70 THUM Wiring for TEC2000**



- 
5. Verify that all connections are secured and make sure the actuator is configured for “Network Mode” (Setpoint changes via THUM will not be accepted if not in proper mode), and then close the actuator.

**11.1.1 Wireless THUM with Intrinsically Safe Barrier on TEC2000**

An Intrinsically Safe Barrier is available for use with the wireless THUM in oil and gas applications. The IS Barrier is wired between the THUM and the STC. The IS Barrier is installed in its own explosion proof case with sealed conduits above and below that separates the intrinsically safe THUM from the explosion proof TEC 2000. It is important that the seal in the conduits above and below the IS Barrier is not disturbed when servicing the unit. A wiring chart for this application is shown below that shows the connections between the THUM and IS Barrier and between the IS Barrier and the STC.

Figure 71 THUM Intrinsically Safe (IS) Barrier

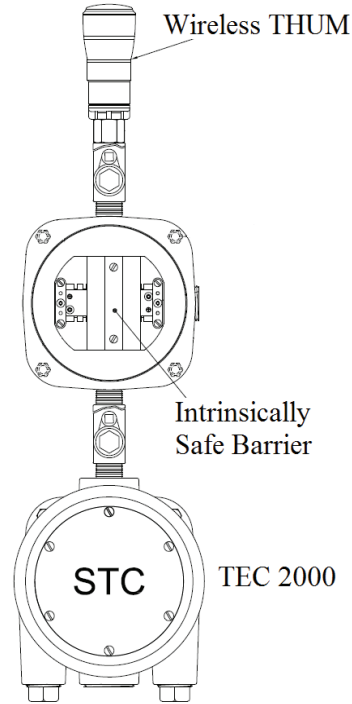


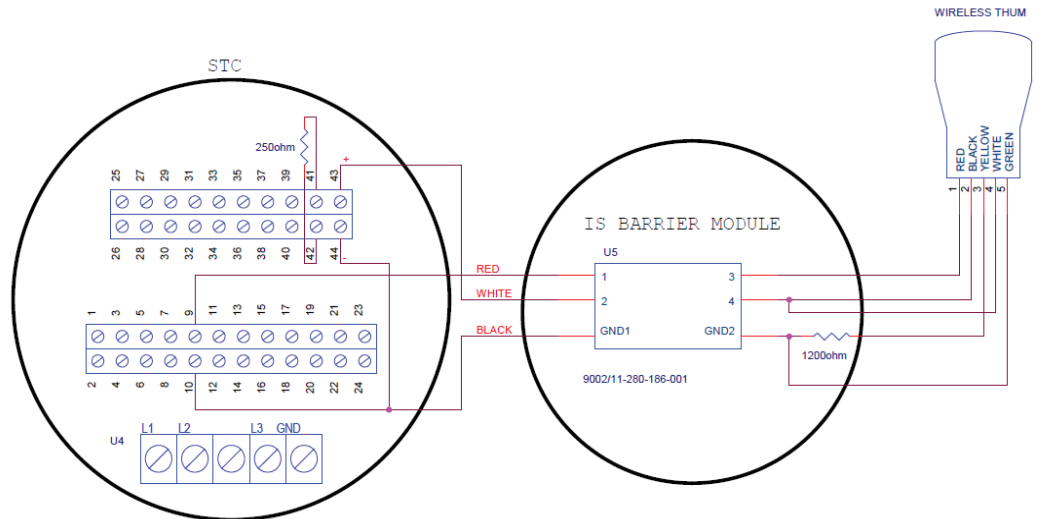
Table 35. Intrinsically Safe Wiring Chart (1)

IS Barrier	
1	Red from STC
2	White from STC
GND Screw	Black from STC
3	Red from THUM
4	Black and White from THUM
GND Screw	Green and Yellow w/ 1200 ohm resistor

Table 36. Intrinsically Safe Wiring Chart (2)

TEC2000 STC	
9	Red
10	Black
41	250 ohm Resistor Side A
42	250 ohm Resistor Side B
43	White
44	Black

**Figure 72 Intrinsically Safe Wiring Diagram**



## 11.2 Component Installation on M2CP

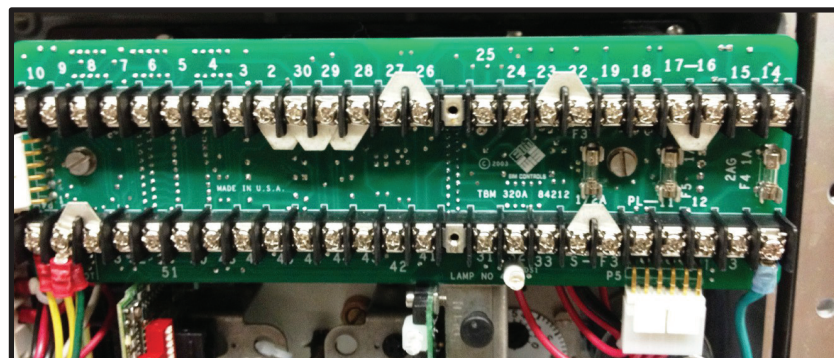
**NOTE:**

The Local Control Station has priority over all control sources. When equipped and activated, no other control sources, including HART, can control the actuator until the Local Control Station selector switch is returned to the “Remote/Auto” position, returning control to the other “electronic” control means.

The Local Control Station has two sets of controls; 1) LOR selector switch with three (3) positions (Local/Manual, OFF, and Remote/Auto) and 2) Control push-buttons with three (3) buttons (Open, Stop, and Close).

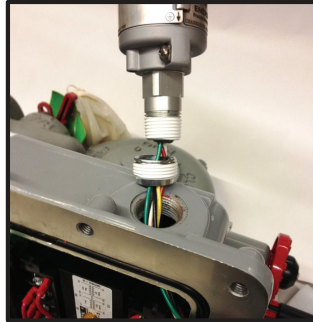
1. Disconnect the actuator from the power source
2. Open the cover to expose the internal electronics.
3. Unplug the 320A terminal interface board located inside the control housing by loosening screws (A) and (B) and carefully pulling the board forward to expose the mounting location for the CAM16 board (no wires need to be disconnected).

**Figure 73 320A Terminal Interface Board**



4. Insert the Wireless HART THUM and a 3/4 to 1/4 conduit reducer into one of the access ports in the actuator control housing. Then, tighten securely, making sure not to damage wires while turning.

**Figure 74 Wireless HART THUM Insertion**



**NOTE:**

Reducer bushings used for non-hazardous locations installation only.  
 Teflon tape should be applied to both the THUM and reducer bushing threads to prevent galling.

5. Remove the male half of the Pluggable Terminal Block J4 on the CAM16 board.
6. Carefully insert the CAM16 board connector pins into the socket on the 320B board and press CAM16 board on to the (2) mounting legs.
7. Attach the wires from the Wireless HART THUM to the CAM16 J4 as shown in Table.

**Table 37. THUM Wire Configuration**

CAM16	THUM
I-	White
I+	Yellow

8. Reinsert the male half of the J4 connector into its base.
9. Reattach the 320A terminal interface board by plugging it into the connectors and retighten screw.
10. Connect the HART Wireless THUM GREEN wire to terminal #X2 on the 320B terminal board (Optional).
11. Connect the Wireless THUM to 320B Board as follows:

**Table 38. THUM Wire Configuration for 320B**

320B	THUM
26	Red
29	Black

12. Verify that all connections are secured and make sure the actuator is configured for “Network Mode” (Setpoint changes via THUM will not be accepted if not in proper mode), and then close the actuator.

## 11.3 Component Installation on MPA

---

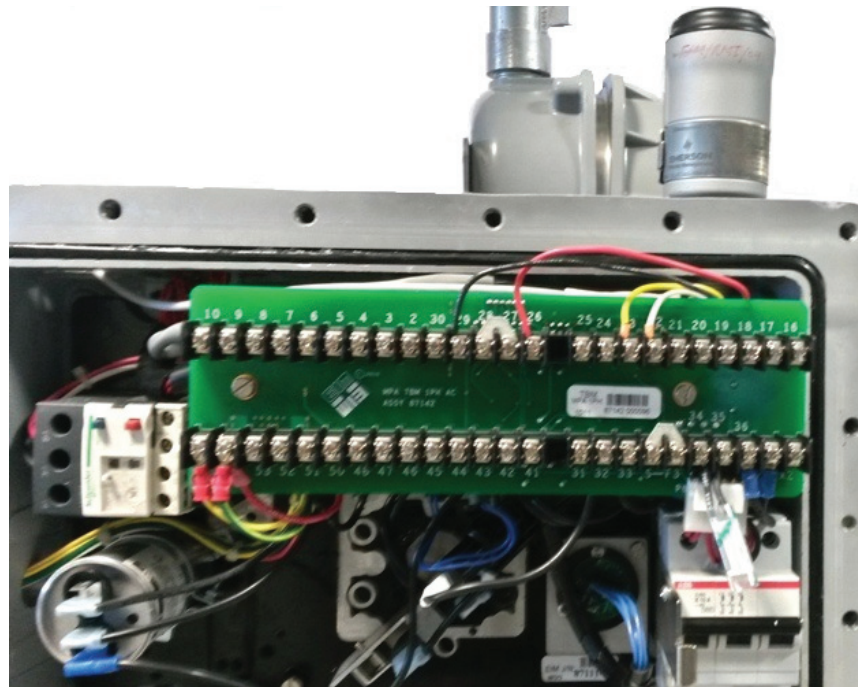
**NOTE:**

The following instructions apply to actuators installed in non-hazardous locations only.

1. Disconnect the actuator from the power source.
2. Open the cover to expose the internal electronics.
3. Locate the front cover of the MPA and open it to access the internal electronics.
4. Insert the Wireless HART THUM and a 3/4 to 1/4 conduit reducer into one of the access ports in the actuator control housing. Then, tighten securely, making sure not to damage the wires while turning.

---

**Figure 75** Wireless HART THUM in MPA



---

**NOTE:**

Reducer bushings used for non-hazardous locations installation only.  
Teflon tape should be applied to both the THUM and reducer bushing threads to prevent galling.

---

- Using appropriate tools, verify that the internal pre-wired connections between the MPA TBM and the CAM16 P1 connector are as shown below. If the wires are disconnected on the TBM, connect them as shown:

**Table 39. MPA Pre-Wired Connections**

CAM16	MPA
O-	20
O+	21
I-	22
I+	23

- Next, connect the THUM wires to the TBM as shown in the following table:

**Table 40. THUM Wires to TBM Configuration**

MPA TBM	THUM
22	White
23	Yellow
26	Red
29	Black

- Verify that all connections are secured and make sure the actuator is configured for “Network Mode” (Setpoint changes via THUM will not be accepted if not in proper mode), and then close the actuator.

## 11.4 Component Installation on EHO

- Disconnect the actuator from the power source and open the back cover to expose the STC.
- Apply Teflon tape to both, the THUM and the reducer bushing threads to prevent galling.
- Insert the Wireless HART THUM and a 3/4 to 1/4 conduit reducer into one of the access ports in the actuator control housing. Then, tighten securely, making sure not to damage wires while turning.

**NOTE:**

Reducer bushings used for non-hazardous locations installation only.

- Once the THUM is securely installed, wire as shown below:

**Table 41. EHO and THUM Wiring Configuration**

EHO STC	Connection	THUM
9	24 VDC	Red
10	0 VDC	Black 1200 OHM Series Resistor
24	Shield	Green (Optional)
43	HART (+)	Yellow
44	HART (-)	White

**NOTE:**

Resistors and other required parts are available by ordering Part No. 87263 “Wireless HART THUM Kit”.

Figure 76 THUM on the EHO STC



5. Verify that all connections are secured and make sure the actuator is configured for “Network Mode” (Setpoint changes via THUM will not be accepted if not in proper mode), and then close the actuator.

## 11.5 Component Installation on HQ

1. Disconnect the actuator from the power source and open the top cover to expose the internal electronics.
2. Apply Teflon tape to both, the THUM and the reducer bushing threads to prevent galling.
3. Insert the Wireless HART THUM and a 3/4 to 1/4 conduit reducer into one of the access ports in the actuator control housing. Then, tighten securely, making sure not to damage wires while turning.

**NOTE:**

Reducer bushings used for non-hazardous locations installation only.

4. Once the THUM is securely installed, wire as shown below:

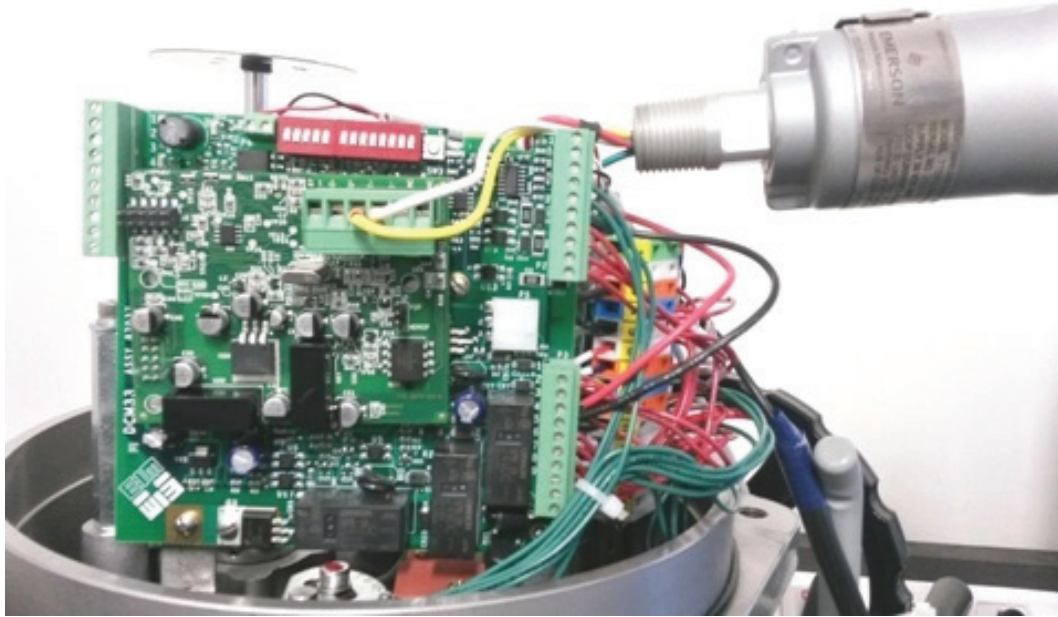
Table 42. THUM Component Wiring (1)

CAM16	THUM
I-	White
I+	Yellow

Table 43. THUM Component Wiring (2)

HQ	THUM
P3-3	Red
P3-4	Black

Figure 77 THUM Wiring in PCB



5. Verify that all connections are secured and make sure the actuator is configured for “Network Mode” (Setpoint changes via THUM will not be accepted if not in proper mode), and then close the actuator.

# Section 12: THUM Programming and Wireless Setup

## 12.1 Set Up Gateway Internet Access for AMS Session

**NOTE:**

A special crossover cable must be used for this application.

1. Connect crossover Ethernet cable between computer and Ethernet #1 port on Gateway.
2. On your PC, navigate to: Control Panel > View Network Connections > Local Area Connection > Properties > Internet Protocol Version 4 (TCP/IPv4) > Properties .
3. Select “Use the following IP Address” and enter 192.168.1.12 (subnet mask will come up) select Ok and then Ok on the next prompt.
4. Open Internet Explorer and enter the following address: HTTPS://192.168.1.10 and hit enter. (\*If Security certificate message comes up, you may have to select “ Diagnose Connection Problem”).
5. Select “Continue to Website” and enter for Username “admin” and Password “default”.
6. Select “Explorer” in left margin to read devices (this process might take up to 15 minutes).

## 12.2 Set Up a Computer Using a HART Modem

1. Install all software/drivers necessary for your HART modem prior to connection.
2. Open AMS Device Manager and navigate to Configuration > Add > HART Modem > Install > Next > Next and select “Hand held device as secondary HART master”, then select the correct COM port for your HART modem.
3. Go to “Wireless HART adapter block” and check “include Wireless HART adapter” then click finish.

## 12.3 THUM Programming – Join to Gateway Network Using a PC

1. Set up computer internet for Gateway “Refer to Appendix A -1”.
2. Plug HART modem into computer.
3. Open AMS and navigate to Device Connection icon > HART modem > THUM > to read the parameters.
4. Select Configure > Join Device to Network > Enter Network ID and enter the Network ID inside the cover of the Gateway, then click next.
5. Enter Join Key (Number shown on THUM tag). All Three remaining “Join Keys” are (8) zeros.
6. Select “Network Configuration” on AMS menu and select “Add”.

## 12.4 Running AMS to Change the Device Setpoint

1. Navigate and start your AMS Device Manager application.
2. For Username enter “admin” – leave password field blank.
3. Locate and select the “Device Connection View” in the middle of the toolbar.
4. Double click on Wireless Network to see devices.

---

### NOTE:

The message “Network disruption was detected” means no devices are sensed by gateway. If no devices show up on the screen, right click on Wireless Network and select Rebuild and Identify hierarchy.

---

5. Expand Gateway > myNet > THUM and double click on the device Logo.
6. Set the “Time” in the lower left hand corner of the screen to “Current” from the drop down box and answer “Yes” when prompted to continue.
7. Expand “Online” on the Configure/Setup Screen > Detailed Setup > Valve Control > Setpoint and select the “Change Setpoint” method.
8. Select “Yes” and click next when the “Writing Setpoint requires placing the device in Out of service mode...” Prompt shows up.
9. Enter the desired Setpoint for the device and click “Next”.
10. After you receive the “Write Setpoint success” message, select “next”, then “finish” to complete the “Change Setpoint method”.
11. To select a different Setpoint, repeat Steps 2.7 – 2.10.

## 12.5 Return Network Settings to Original Settings after AMS Session

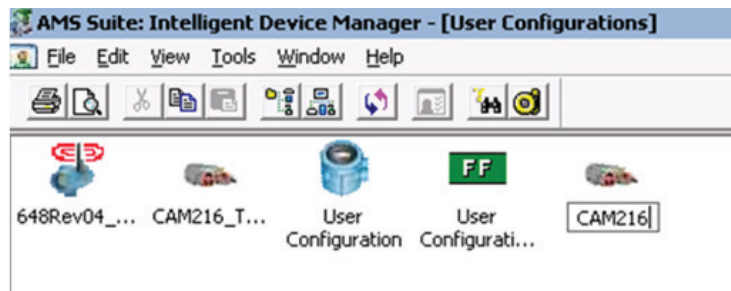
1. On your PC, navigate to: Control Panel > View Network Connections > Local Area Connections > Properties > Internet Protocol Version 4 (TCP/IPv4) > Properties.
2. Select the option “Obtain an IP address automatically and click ok.
3. Your settings are back to their original configuration.

## Section 13: AMS Bulk Transfer

### 13.1 Create and export Bulk User Configuration File Template

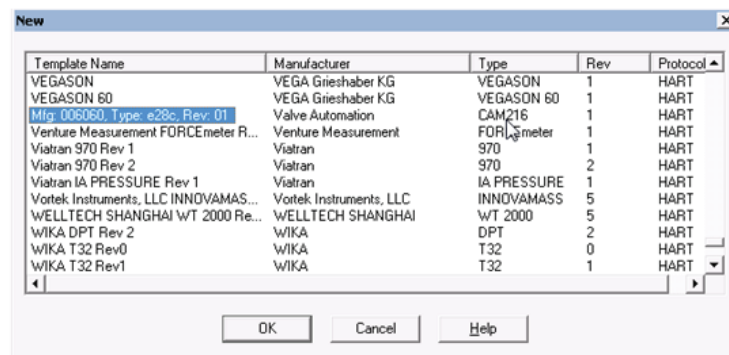
**13.1.1** Open AMS Device Manager and navigate to “View > User Configurations”. If necessary, use the “Window” menu to rearrange the windows on AMS to be able to see the User Configuration menu.

**Figure 78** Configuring AMS Suite



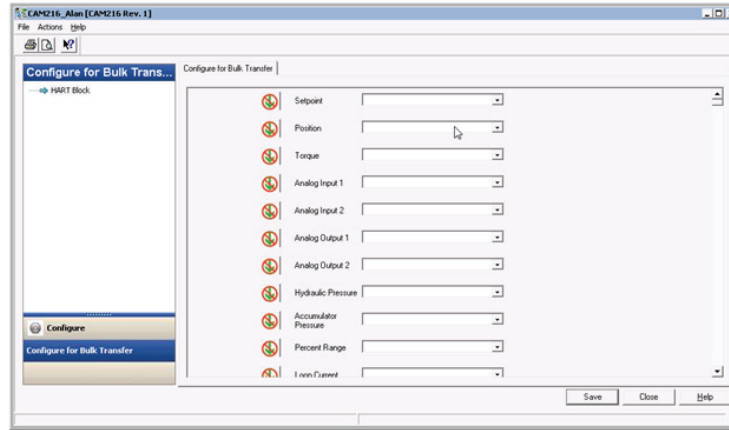
**13.1.2** From the User Configuration menu, right-click on the background and select “New”; then, navigate to the device and find the template for Manufacturer: Valve Automation and Type: CAM216. Select **OK**.

**Figure 79** User Configurations Menu



**13.1.3** After a few seconds, the device template should appear on the User Configuration screen. Rename the template and then right-click and select “Configure for Bulk Transfer”.

Figure 80 Configuring for Bulk Transfer



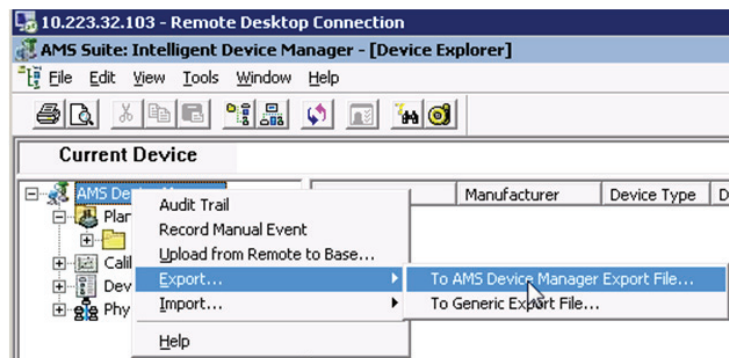
13.1.4 On the “Configure for Bulk Transfer” Menu, click on the green arrow icon to select whether that parameter will be enabled/disabled for the bulk transfer. Enter the information on the blank space and then click save to save your changes.

Figure 81 Enabling or Disabling a Parameter



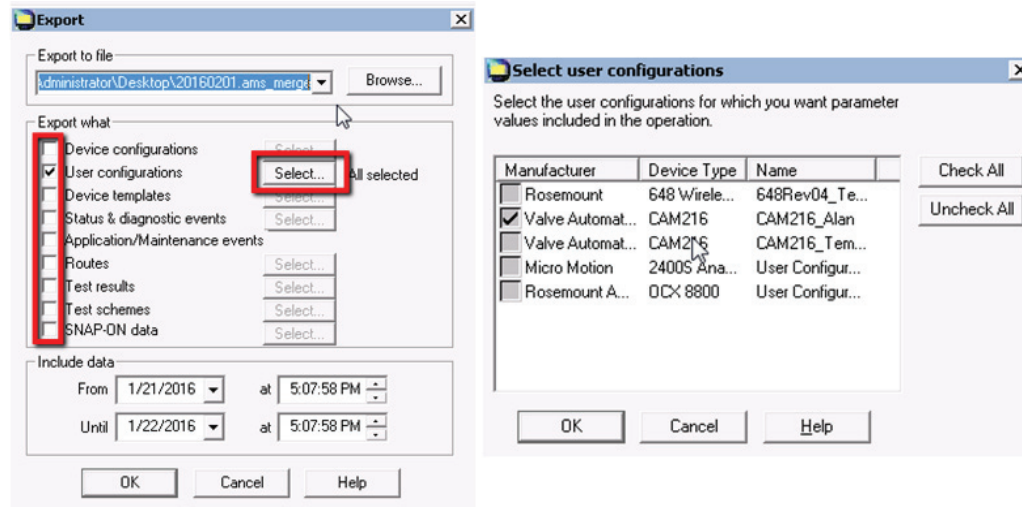
13.1.5 Navigate to AMS Device Explorer and right click on the “AMS Device Manager Icon” > Export > To AMS Device Manager Export File”

Figure 82 Exporting the File



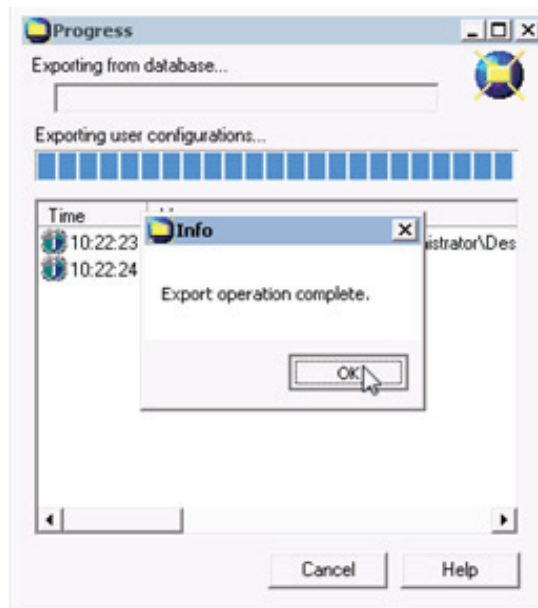
13.1.6 On the **Export** menu, uncheck all other options except the user Configurations” and browse for your file to save to. Then, click on “Select...” button and on the “Select user configuration” uncheck the devices that you do not wish to configure.

Figure 83 Export Menu Options



13.1.7 After selecting your device, click on to begin the export. This process might take some time depending on how many parameters are selected. When you receive the “Export operation Complete”, press **OK** to continue.

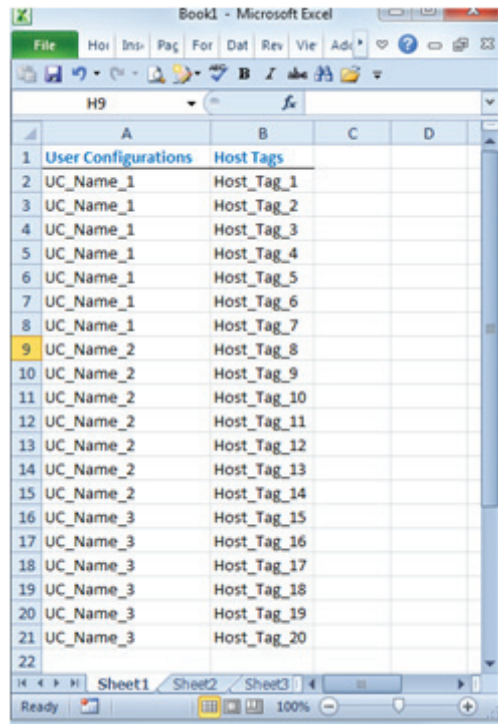
Figure 84 AMS File Export



## 13.2 Bulk Configuration Transfer Utility Procedure

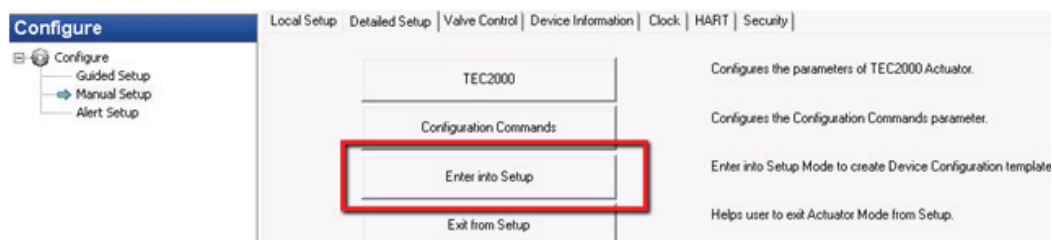
**13.2.1** To transfer parameter data from the user configuration with the bulk transfer utility, create a new spreadsheet on Microsoft Excel. On the spreadsheet, use column 1 for “User Configuration” and Column 2 for “Host Tags”. Once all the information is entered, save the document.

**Figure 85** Transferring Parameter Data



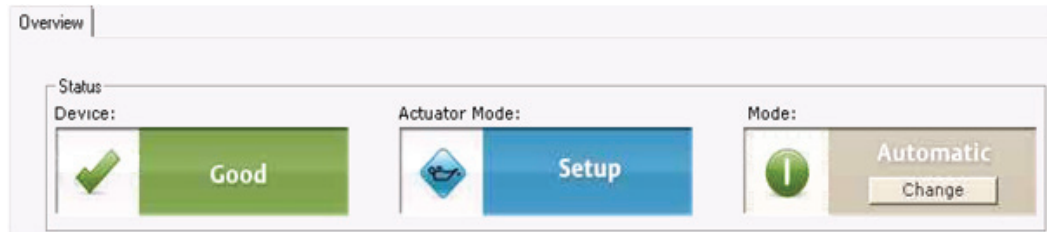
**13.2.2** Before sending the configuration, the device must be placed into “Setup” mode, This can be done from AMS Device manager by opening the desired device DD and navigating to “Configure > Manual Setup > Detailed Setup” and use the configuration commands to place the device into “Setup Mode”

**Figure 86** Entering Setup Mode



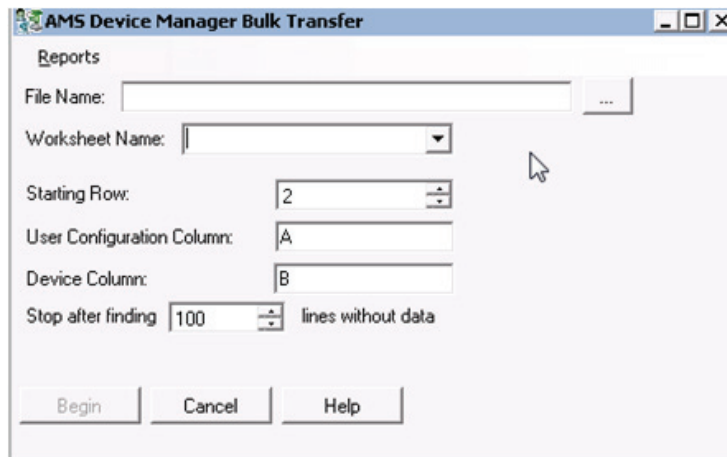
**13.2.2.1** Note that when device is this mode, Commands from the host will be ignored. You might to back to Overview Menu to verify the device is in setup mode.

Figure 87 Transfer Mode



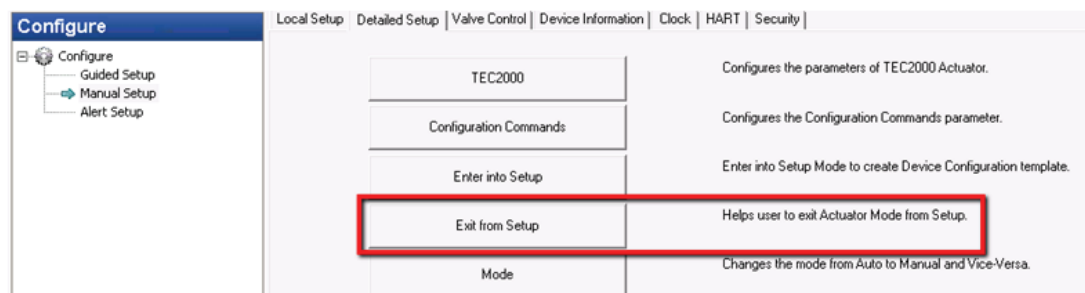
13.2.3 Navigate to “AMS Device Manager > Tools > Bulk Transfer utility”. Browse for the file name and enter the correct information for your spreadsheet. Press Begin to start the transfer.

Figure 88 Start Transfer



13.2.4 When transfer is completed; navigate to “Configure > Manual Setup > Detailed Setup” and use the configuration commands to exit setup mode and return the device to normal operation.

Figure 89 Transfer Complete



# Section 14: Troubleshooting

## 14.1 Communication Issues

Emerson HART CAM16/216 is equipped with 2 LEDs - D5 and D6, indicators for troubleshooting communication issues. Refer to the table below to verify proper installation and operation of CAM16/216.

**Table 44. Known Communication Issues**

Issue	Description	Troubleshooting
Normal Operation (Communicating)	D6 yellow blinking indicates good communication between CAM16/216 Board and Actuator, whereas D5 red blinking indicates good communication between HART host and CAM16/216 Board	No action needed
Normal Operation (Standby)	D6 (yellow) indicates communication between CAM16/216 Board and Actuator. D5 (red) indicates communication between HART host and CAM16/216 Board, in Idle condition if not communicating with HART host D5 will be off and D6 will be blinking. When actuator is communicating with HART master both LEDs would be blinking.	If device is in good status, a command to read parameters can be sent to verify that D5 and D6 begin flashing.  If successful, device is functioning properly.
Bad ACM communication	D6 LED is not flashing and is continuously ON or OFF.	When D6 is not flashing; there is bad communication with the actuator. Verify that the CAM is properly aligned with the ACM connector and all connections are properly secured
Bad HART communication	D5 LED is not flashing and is continuously ON or OFF.	Verify connections as well as polarity of connections of J4 in CAM16 and J6 in CAM216.  Verify that proper current and voltage is applied to the HART segment.

## 14.2 Control Issues

**Table 45. Known Control Issues**

Issue	Description	Troubleshooting
Can read status but cannot control.	Incorrect control mode configuration or control knob is in off mode.	Make sure control knob is set to Remote mode.  Verify if the device is properly configured for "Analog" when trying to control from AI 4-20mA or "Network" when attempting to send commands from host.
Analog control is not properly functioning.	When device is configured for analog control the 4-20mA signal does not allow full stroke control.	Calibrate the AI on the device; refer to the electric actuator manual for details.
Sending commands does not move the valve.	When sending Open, Stop, Close command or Setpoint (0-100%) the valve doesn't respond.	Ensure that the actuator is properly configured for HART Block mode or HART Modulation (Setpoint) mode.
Valve does not move, yellow light flashing on LDM screen.	Incorrect control mode configuration or control knob is in off mode.	Make sure control knob is set to Remote mode.  Verify if the device is properly configured for "Analog" when trying to control from AI 4-20mA or "Network" when attempting to send commands from host.

## Section 15: Trademark Acknowledgements

1. DCMLink™ Software, AMS™ Intelligent Device Manager, Plant Web®, Delta V™ are the trademarks owned by one of the companies in the Emerson Process Management business platform of Emerson Electric Co.
2. Emerson Process Management, Emerson, and the Emerson logo are the trademarks and service marks of Emerson Electric Co.
3. HART is a registered trademark of the HART Communication Foundation.

All other company and product names mentioned in this document are trademarks or registered trademarks of their respective companies.

## Section 16: Document Revision

**Table 46. Revision Overview**

REVISION	DATE	MODIFIED BY	APPROVED BY	DESCRIPTION
0.1	April 27, 2015	Aseem	Mahesh	Initial draft
0.2	May 27, 2015	Aseem	Mahesh	Updated review points
1	January 5, 2016	Charles Khalid Rico	Mahesh	Converted to new format

# Appendix A: List of Certificates and Drawings

## A.1 Certificate of Registration HCF Verified



### Certificate of Registration FieldComm Group Verified

<u>Valve Automation</u> Manufacturer	<u>CAM16</u> Product Name
<u>6060</u> Manufacturer ID (Hex)	<u>E28B</u> Expanded Device Type (Hex)
<u>7</u> HART Protocol Revision	<u>01</u> Device Revision (Hex)
<u>01</u> Hardware Revision (Hex)	<u>01</u> Software Revision (Hex)
<u>5/1/2015</u> Test Date	<u>FieldComm Group</u> Verification Method

The above product has successfully completed the validation process and meets the requirements to be "HART REGISTERED".

"HART REGISTERED" products conform to GB/T 29910.1-6-2013 and IEC 61158 standards.

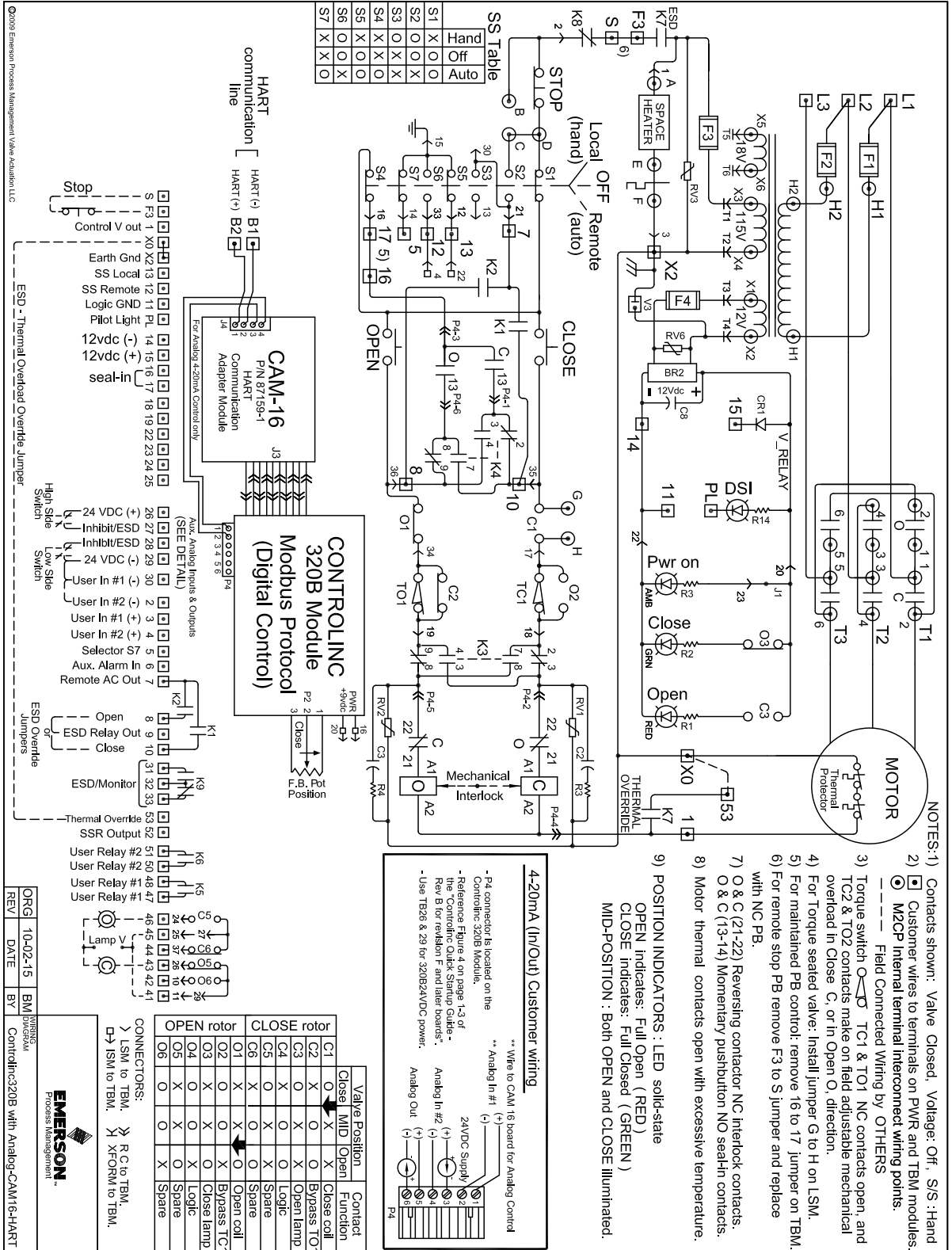
Registration Number:	<u>L2-06-1000-441</u>	Registration Issue Date:	<u>Sept. 9, 2015</u>	Approval:	<u><i>T. Y. Mastus</i></u>
----------------------	-----------------------	--------------------------	----------------------	-----------	----------------------------



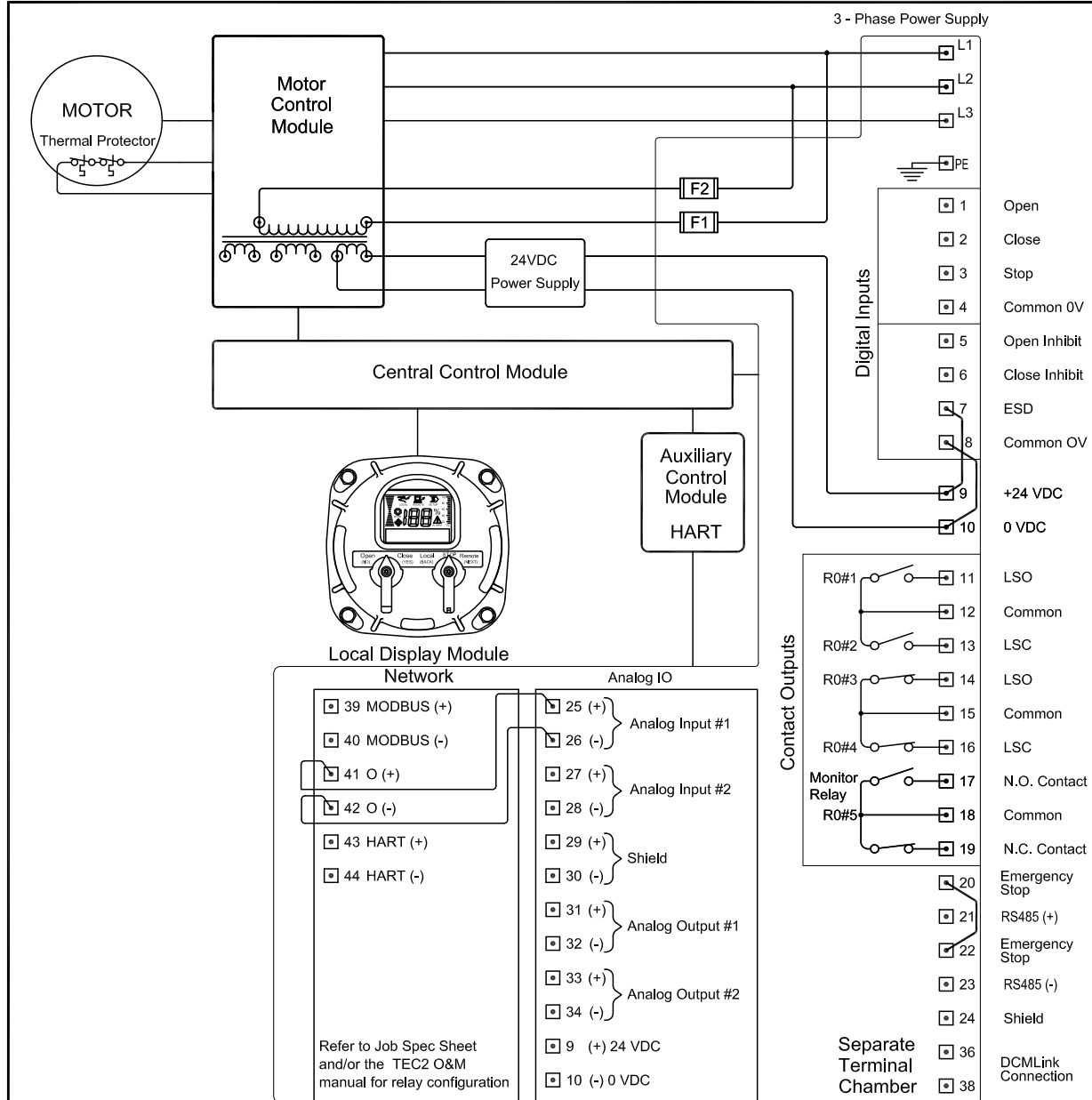
**FIELD COMM GROUP™**  
Connecting the World of  
Process Automation

HART® is a registered trademark of FieldComm Group

# A.2 Wiring Diagram for Controlinc320B with Analog-CAM16-HART



## A.3 Wiring Diagram for TEC2 -3PH-CAM216-HART



- NOTES:
- 1) All digital inputs have an input voltage range of 18-150 VDC or 20-250 VAC.
  - 2) All digital relay outputs are rated for 5A @ 30 VDC or 5A @ 250 VAC Resistive, 2A Inductive load.
  - 3) Jumpers shown connected between terminals are permissible but not required.
  - 4) Emergency stop requires jumper or normally closed contact (actuator stops when contact open).
  - 5) Remote display communication port is RS-485.
  - 6) If bare wires (without terminals) are connected, remove a maximum of .25 inch insulation.
  - 7) User replaceable primary fuses (F1 and F2) are located in the Terminal Chamber Enclosure. All transformer secondary fuses are automatic resetting.
  - 8) Contact Outputs and Output Switch Contact Development Chart shown for default configuration only. User may redefine all Outputs (See TEC2 Installation & Operation Manual).

ARM	CBM	CCM	DBM	LDM	MCM	RDM	STC
00	00	01	00	01	02	00	01

Output Switch Contact Development				
	Valve Position			Contact Function
	Close	MID	Open	
LSO				Open Limit
LSC				Close Limit
LSA				Open Limit
LSB				Close Limit

**EMERSON**  
Process Management

OWNED BY: BM ORIGINAL DATE: 11-02-15

WIRING DIAGRAM TEC2 -3PH-CAM216-HART



**World Area Configuration Centers (WACC) offer sales support, service, inventory and commissioning to our global customers. Choose the WACC or sales office nearest you:**

***NORTH & SOUTH AMERICA***

19200 Northwest Freeway  
Houston, TX 77065  
USA  
T +1 281 477 4100  
F +1 281 477 2809

Av. Hollingsworth,  
325, Iporanga Sorocaba  
SP 18087-105  
Brazil  
T +55 15 3238 3788  
F +55 15 3228 3300

***ASIA PACIFIC***

No. 9 Gul Road  
#01-02 Singapore 629361  
T +65 6501 4600  
F +65 6268 0028

No.1 Lai Yuan Road  
Wuqing Development Area  
Tianjin 301700  
P.R. China  
T +86 22 8212 3300  
F +86 22 8212 3308

For complete list of sales and manufacturing sites, please visit [www.emersonprocess.com/valveautomationlocations](http://www.emersonprocess.com/valveautomationlocations)  
Or contact us at [info.valveautomation@emerson.com](mailto:info.valveautomation@emerson.com)

***MIDDLE EAST & AFRICA***

P. O. Box 17033  
Dubai  
United Arab Emirates  
T +971 4 811 8100  
F +971 4 886 5465

P. O. Box 10305  
Jubail 31961  
Saudi Arabia  
T +966 3 340 8650  
F +966 3 340 8790

24 Angus Crescent  
Longmeadow Business Estate  
East P.O. Box 6908; Greenstone  
1616 Modderfontein, Extension 5  
South Africa  
T +27 11 451 3700  
F +27 11 451 3800

***EUROPE***

Berenyi u. 72- 100  
Videoton Industry Park  
Building #230  
Székesfehérvár 8000  
Hungary  
T +36 22 53 09 50  
F +36 22 54 37 00

[www.emersonprocess.com/valveautomation](http://www.emersonprocess.com/valveautomation)

©2016 Emerson Process Management. All rights reserved.

The Emerson logo is a trademark and service mark of Emerson Electric Co. All other marks are property of their respective owners.

The contents of this publication are presented for information purposes only, and while every effort has been made to ensure their accuracy, they are not to be construed as warranties or guarantees, express or implied, regarding the products or services described herein or their use or applicability. All sales are governed by our terms and conditions, which are available on request. The customer is solely responsible for the selection, use and maintenance of the products and equipment. We reserve the right to modify or improve the designs or specifications of our products at any time without notice.

