

Biffi ICON3000

Modbus RTU Module



This page is intentionally left blank

Table of Contents

Section 1: Introduction

1.1	References	1
1.2	Modbus RTU or ASCII	1

Section 2: Operation and Storage

	Operation and Storage.....	2
--	----------------------------	---

Section 3: Communication Features

	Communication Features.....	3
--	-----------------------------	---

Section 4: Modbus RTU Interface

4.1	On Board Indications and Jumpers on ICON3000.....	6
4.2	On Board Indications and Jumpers on ICON3000v2.....	7

Section 5: Modbus RTU Protocol Description

	Modbus RTU Protocol Description.....	8
--	--------------------------------------	---

Section 6: Modbus Wirings

6.1	RS485 Transmission Mode	9
-----	-------------------------------	---

Section 7: Modbus I/O List

7.1	Discrete Inputs.....	12
7.2	Coils.....	13
7.3	Analog Inputs.....	15
7.4	Holding Registers.....	22

Section 8: Modbus Function Description

8.1	Function Code 01 (0x01) Read Coils Status.....	50
8.2	Function Code 02 (0x02) Read Discrete Inputs	51
8.3	Function Code 03 (0x03) Read Holding Registers	52
8.4	Function Code 04 (0x04) Read Input Registers	53
8.5	Function Code 05 (0x05) Write Single Coil	54
8.6	Function Code 06 (0x06) Write Single Register.....	55
8.7	Function Code 08 (0x08) Diagnostic	56
8.7.1	Sub-Function 00 (0x0000) Return Query Data	56
8.7.2	Sub-Function 11 (0x000B) Return Bus Message Count.....	56
8.7.3	Sub-Function 12 (0x000C) Return Bus Communication Error Count .	56
8.7.4	Sub-Function 13 (0x000D) Return Bus Exception Error Count	57
8.7.5	Sub-Function 14 (0x000E) Return Slave Message Count	57
8.7.6	Sub-Function 17 (0x0011) Return Slave Busy Count	57
8.7.7	Sub-Function 18 (0x0012) Return Bus Character Overrun Count	57
8.8	Function Code 15 (0x0F) Write Multiple Coils	58
8.9	Function Code 16 (0x10) Write Multiple Registers.....	59
8.10	Function Code 17 (0x11) Report Slave ID.....	60

8.11	Function Code 20 (0x14) Read File Record.....	61
8.11.1	File Number 2: Alarms Log.....	62
8.11.2	File Number 3: Warnings Log.....	63
8.11.3	File Number 4: Connections Log.....	64
8.11.4	File Numbers from 1000 to 1100: FST Open Torque Curves.....	64
8.11.5	File Numbers from 2000 to 2100: FST Close Torque Curves.....	65
8.11.6	File Numbers from 3000 to 3016: PST Curves.....	66
8.11.7	File Numbers from 3500 to 3516: EFS Curves.....	68
8.11.8	File Number 5000: Events Log.....	69
8.11.9	File Number 5100: Recorders Log.....	70
8.11.10	File Number 5200: T-Recorders Log.....	71
8.11.11	File Numbers from 5300 to 5304: Cards Report.....	72
8.12	Exception Codes.....	73

Section 9: Configuration via Local Interface

9.1	BUS Control.....	74
9.1.1	Settings for ICON2000v4 and ICON3000 Actuators.....	74
9.1.2	Settings for ICON3000v2 Actuators.....	76
9.2	Positioner Function.....	78
9.3	Fail-Safe Function.....	79
9.4	Viewing Transmission Info.....	80
9.5	BUS Signal Failure Indication.....	80
9.6	Actuator Terminal Board.....	81
9.6.1	Terminal Board Connections Connections for ICON2000v4 and ICON3000.....	81
9.6.2	Terminal Board Connections for ICON3000v2.....	82

Section 10: Annex A

10.1	Replacement of 494MOD1000 with 494MOD1200 or 494MOD3200 (up to ICON3000).....	83
10.2	Replacement of 494MOD*** with Modbus RTU Interface (ICON3000v2).....	85

Section 11: Annex B - Writing Modbus I/O Data

Annex B - Writing Modbus I/O Data.....	88
--	----

Section 12: Annex C - PST Command Requirements

Annex C - PST Command Requirements.....	89
---	----

Section 1: Introduction

The Modbus RTU Module is the Modbus Interface card that allows connecting the ICON3000 actuator families to a Modbus RTU serial communication line. The module has its microprocessor. It is controlled by a program stored internally. It works as a pure bus interface and does not affect the actuator control integrity. It is installed inside the actuator housing and takes the electrical power from the actuator power supply module. The RS485 Interface is located on the module board. The data lines are fully isolated from the actuator electronics.

All features described in this document are applicable for Modbus RTU Interface firmware revision 2.01 or subsequently.

Modbus RTU Interface can be mounted on ICON3000 actuator base card revision 9.00 or higher.

The ICON3000v2 actuator can be equipped with Modbus RTU Interface firmware revision 4.00 or subsequently.

The ICON3000v2 actuator can be recognized because when it is switched on, the name ICON3000v2 appears on the local screen, as shown in Figure 1.

Figure 1



1.1 References

Modbus over serial line specification and implementation guide V1.02. Available from www.modbus.org.

Modbus application protocol specification V1.1b3. Available from www.modbus.org.

ICON3000 Installation, Operation and Maintenance Manual, VCIOM-08500. Available on www.biffi.it.

1.2 Modbus RTU or ASCII

Modbus protocol is currently supported by most Programmable Logic Controllers (PLCs). Modbus is a very simple Master/Slave serial protocol. It supports both ASCII (rarely used) and Binary (RTU) form of transmission. In ASCII transmission mode each 8-bit byte in a message is sent as 2 ASCII characters. In RTU transmission mode each 8-bit byte is sent as 2 four-bit hexadecimal characters. The main advantage of RTU mode is that it allows greater character density than in ASCII mode at the same baud rate.

The structure of a Modbus message is shown below.

Address	Function	Data	Checksum
---------	----------	------	----------

Section 2: Operation and Storage

The module is designed to work and to be stored in the same environment of the actuator.

Section 3: Communication Features

Communication Protocol:	Modbus RTU
Transmission Technology:	RS485, half duplex
Network Topology:	Line (BUS) structure
Transmission Medium:	Twisted, screened copper cable
Data Rate:	600, 1200, 2400, 4800, 9600, 19200, 38400 bit/s
Device Number:	Maximum 32 devices per segment. If more than 32 devices are present on the BUS, repeaters should be used
Slave Address:	From 1 to 247 (address 0 reserved for broadcast messages), configurable via local operator interface of actuator
BUS Access:	Polling between masters and slaves
Electrical Power:	Actuator powered
BUS Termination:	Available on board, configurable via local operator interface of actuator
Temperature:	-40 °C, +85 °C
Fieldbus Redundancy:	Available by setting the MODE function (CH1, CH2, AUTO)
Auto Baud Rate:	Available by setting "Baud Rate = AUTO"
Modbus Channels:	2 Independent channels
Baud Rate:	Configurable via local operator interface of actuator ICON3000: same baud rate for both channels; ICON3000v2: each channel can assume different baud rate
Addressing:	Configurable via local operator interface of actuator ICON3000: same address for both channels ICON3000v2: each channel can assume different address
Coding System:	8 bits binary, hexadecimal 0-9, A-F. Two hexadecimal characters contained in each 8-bit field of the message
Bits per byte:	1 start bit 8 data bits, least significant bit sent first 1 bit for Even/Odd parity; no bit for no parity; configurable via local operator interface of actuator 1 stop bit with parity; 2 stop bits without parity
Error Check Field:	Cyclical Redundancy Check (CRC)

Section 4: Modbus RTU Interface

The Modbus RTU Module consist in a single PCB that is installed inside the actuator housing. It is connected to the Base Card via strip connector.

The internal wiring connects the RS485 data lines to the actuator terminal board.

The Modbus RTU Module is implemented with two different electronic boards suitable to be installed either in the ICON3000 or in ICON3000v2 actuators.

Figure 2 Top Side

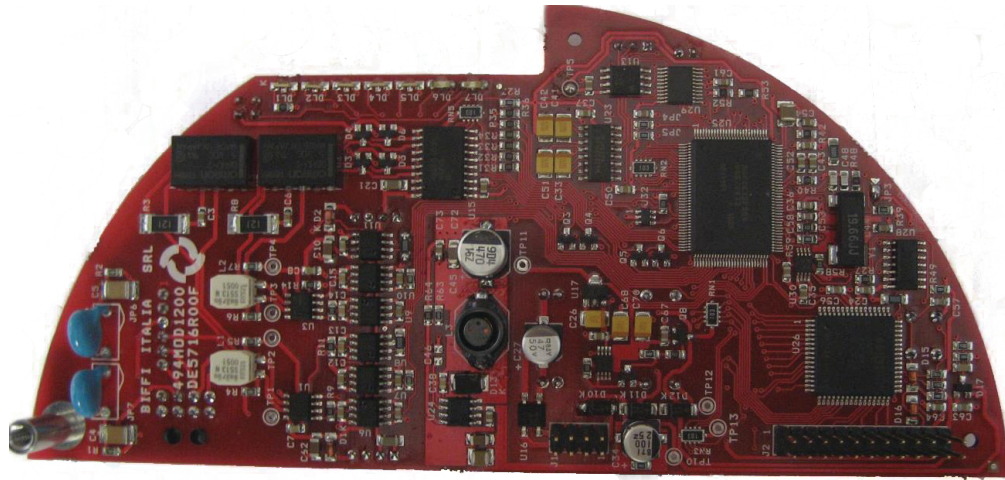
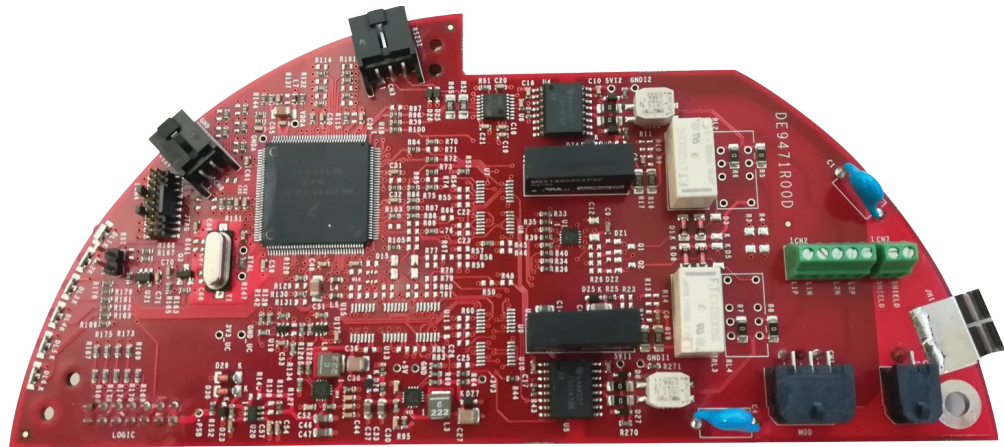

Figure 3 Top Side - Modbus RTU Interface for ICON3000v2 Actuator



4.1 On Board Indications and Jumpers on ICON3000

Seven LEDs are mounted on the Modbus RTU Interface to give the following indications for the field service. LEDs indicators are active only when jumper JP1 is closed.

DL1 (green) Power Supply:	ON: When the Modbus RTU Interface is correctly powered from the main power supply OFF: When the Modbus RTU Interface is not correctly powered from the power supply
DL2 (green) CH1 Comm. Status:	ON: Data message received or transmit from Modbus RTU Interface OFF: Silence between Data Modbus messages BLINK: Auto Baud Rate Running
DL3 (green) CH2 Comm. Status:	ON: Data Message received or transmit from Modbus RTU Interface OFF: Silence between Data Modbus messages BLINK: Auto Baud Rate Running
DL4 (green) Termination CH1:	ON: Termination Resistance Active on CH1 OFF: Termination Resistance Not Active on CH1
DL5 (green) Termination CH2:	ON: Termination Resistance Active on CH2 OFF: Termination Resistance Not Active on CH2
DL6 (red) Base Card Comm. Status:	ON: Communication Errors OFF: Not Communication Errors
DL7 (red) Data Area Empty:	ON: When Data Area on interface card is not yet loaded OFF: When Data Area is completely loaded BLINK: When Data Area is being read from base card
JP1:	LEDs jumper. Short this jumper to power LEDs (default OFF)
JP2:	Program jumper. Used to download new firmware on microcontroller (manufacturer use only)

4.2 On Board Indications and Jumpers on ICON3000v2

Six LEDs are mounted on the Modbus RTU module to give the following indications for the field service.

DL1 (red) Logic Card Comm. Errors:	ON: Communication Errors between Logic and Modbus Interface OFF: Internal Communication between Logic and Modbus Interface works fine
DL2 (green) CH1 Comm. Status:	ON: Modbus Communication active on CH1 OFF: No Modbus Communication on CH1 for at least 5 s BLINK: Auto Baud Rate Running
DL3 (green) CH2 Comm. Status:	ON: Modbus Communication active on CH2 OFF: No Modbus Communication on CH2 for at least 5 s BLINK: Auto Baud Rate Running
DL4 (green) Logic Card Comm. Status:	BLINK: Communication active between Logic and Modbus Interface FIXED ON/OFF: Communication not active between Logic and Modbus Interface
DL5 (green) Modbus Interface Status:	BLINK: Modbus Interface FW running FIXED ON/OFF: Modbus Interface FW locked
DL6 (green) Modbus Interface Power Supply:	ON: Modbus Interface is powered from the main power supply OFF: Modbus Interface is not correctly powered from the main power supply
JP1:	Reset (manufacturer use only)

Section 5: Modbus RTU Protocol Description

Modbus protocol is a messaging structure, used in a wide range of application in process automation to establish master-slave communication between intelligent devices. Since Modbus is only a messaging structure, it is independent from the physical layer. It is traditionally implemented using RS232 or RS422 or RS485. The central controllers (as PLC) communicate via serial connection with field devices (as sensors, actuators). The central controller (called master) reads the input information from the field devices (called slaves) and writes the output information to the slaves. The master initiates the transmission which is called “query.” The slave devices answer by sending the requested data (called “response”) and performing the action requested in the query. The master can address individual slaves or can send a broadcast message to all slaves.

Figure 6 below shows a query-response cycle.

Figure 6

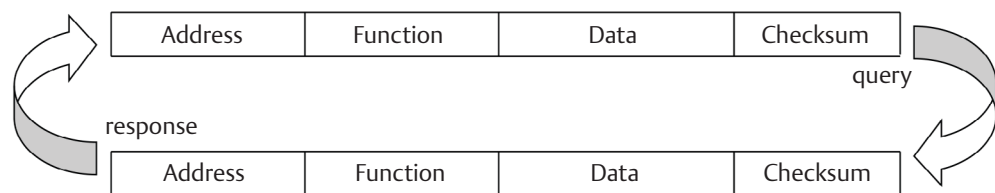

No response from slaves is done in case of broadcast message. Address 0 is used for the broadcast message.

If a slave receives the request, but detects a communication error (parity, CRC, etc.), no response is returned.

If a slave receives the request without a communication error, but cannot handle it (for example, if the request is to read a non-existent output or register), the slave will return an exception response informing the master of the nature of error.

Section 6: Modbus Wirings

The maximum number of master and slave devices in a BUS segment is 32 without repeaters. The maximum cable length depends on the speed of transmission. Higher is the speed shorter should be the cable length.

Figure 7 shows a Modbus RTU configuration with 1 master device and different slave devices.

Figure 7

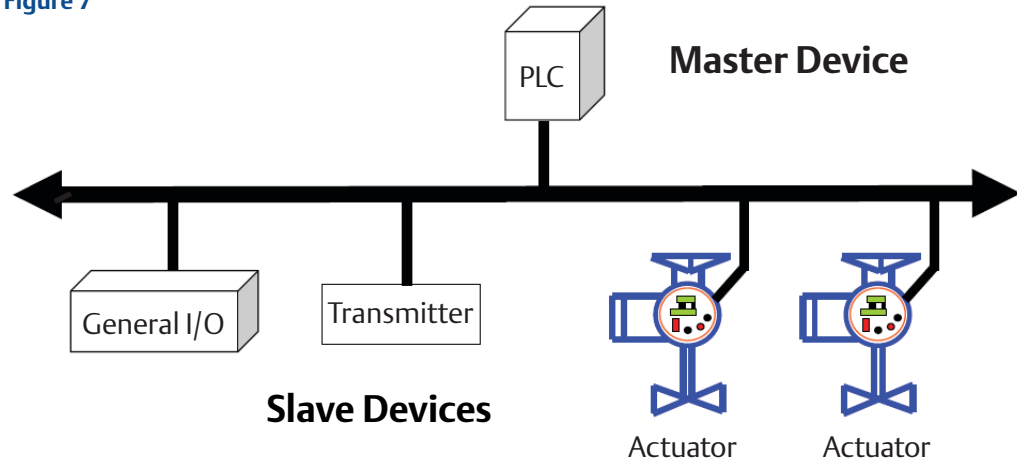

6.1 RS485 Transmission Mode

The Modbus RTU Interface uses a half-duplex, multidrop, serial communication line RS485. The module communicates with the masters via RS485 Interface and the transmission media consists in a shielded twisted pair cable. Transmission speed from 600 bit/s to 38400 bit/s is available.

One unique transmission speed is allowed for all devices on the BUS when the system works.

All devices are connected in a BUS structure. Up to 32 stations (master and slaves) can be connected in one segment. Repeaters should be used to extend the number of devices on one BUS. Addresses range is from 1 to 247. Address 0 is reserved for broadcast messages.

The BUS must be terminated by a resistor of 120 Ω at the beginning and at the end of each segment. Only two terminations in one BUS segment must be provided. To ensure error-free operation and to increase driving capability, pull-up and pull-down resistors should be provided on the termination network. The maximum cable length depends on the transmission speed.

The data lines must not be reversed. To avoid polarity inversion, it is suggested to use different colours for each data line. Use of shielded cable is mandatory for having high system immunity against electromagnetic disturbs. The data lines should be kept separate from all other cables. It should be laid in separate, conductive and earthed cable trunking. It must be ensured that there is no voltage difference between individual nodes of BUS.

Figure 8

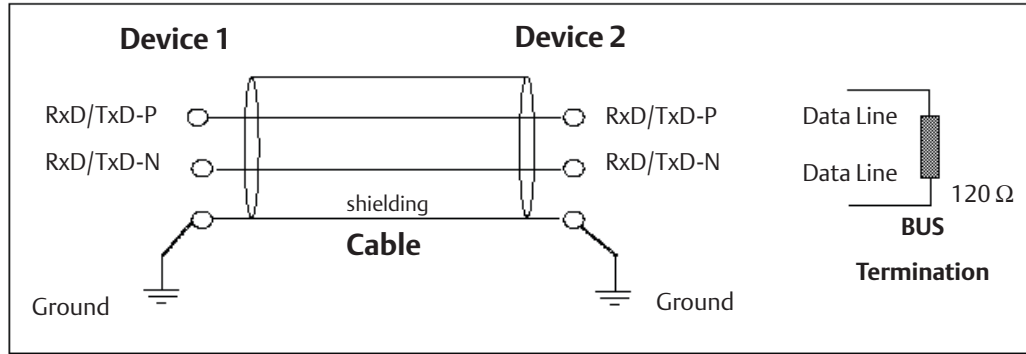

The Modbus RTU Interface takes its electrical supply from the actuator power supply module. The RS485 BUS transceiver is isolated from the actuator electronics. The BUS termination, located inside the actuator, should be used only if the actuator is at the beginning or at the end of the BUS segment and if there is no external termination.

The BUS terminations can be switched on the data lines by means of 2 links, configurable via local operator interface.

Figure 9 shows the wiring in case of single BUS cable.

Figure 9

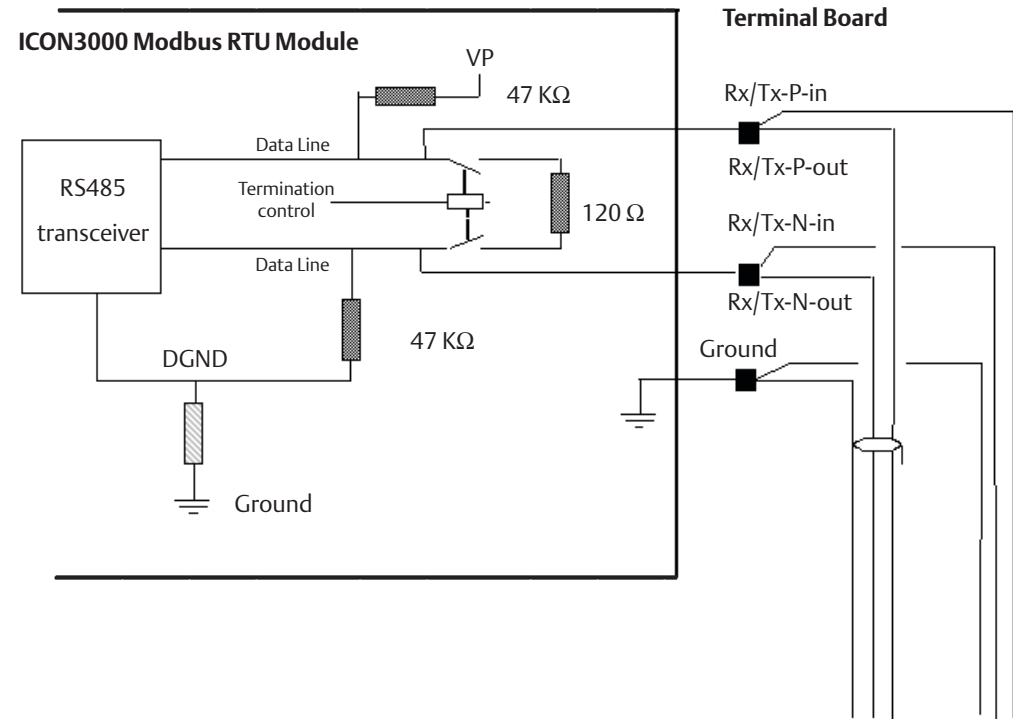
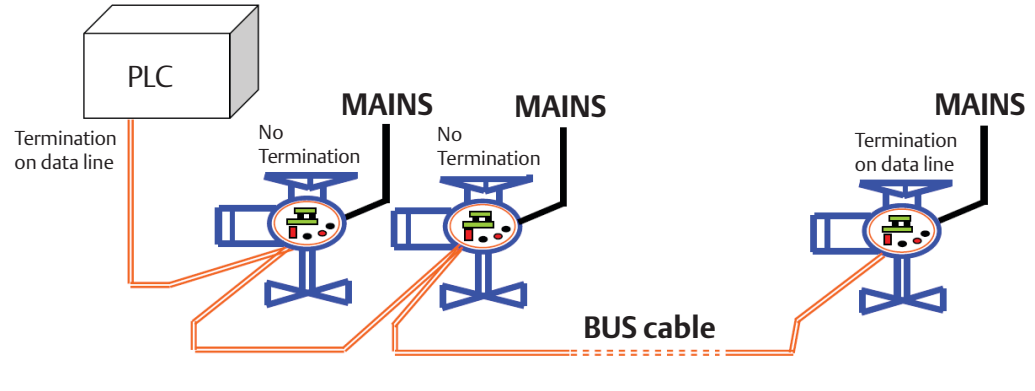

Figure 10 shows the BUS with an actuator at the end of the BUS segment.

Figure 10



The Modbus RTU Interface module is provided with 2 RS485 transceivers and 2 BUS terminations for application with redundant cable. The BUS terminations can be switched on the data lines by means of 2 links, configurable via local operator interface. Both channels can work simultaneously, according to the configuration received from BUS or via local operator interface. On ICON3000v2 actuators Channel1 and Channel2 are completely independent: they can be configured with different Modbus communication settings (different addresses, baud rate, parity).

Figure 11 shows the wiring necessary in case of redundant BUS cable. The termination must be linked to the data lines only if the actuator is at the beginning or at the end of the BUS segment.

Figure 11

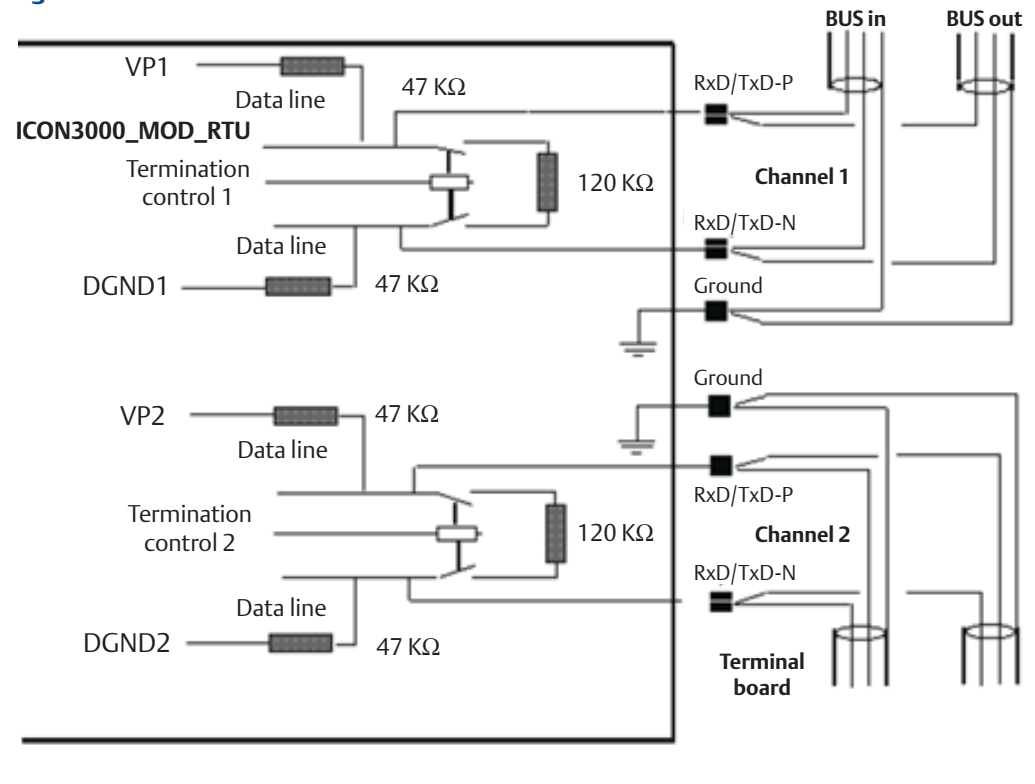

Section 7: Modbus I/O List

The following paragraph describes the I/O composition of the Modbus data map implemented in the ICON3000v2. The Modbus RTU Interface concentrates all the available data in the Holding Register Data Area, but to grant the backward compatibility with the ICON2000v4 and the ICON3000 actuators families, it also maintains the former data structure.

The Modus Map is divided in four areas and each area is accessible via the specific Modbus Function Code as described in Section 8, Modbus Function Description.

ICON3000v2 has been introduced a new security level: to modify the writable Modbus Data (Coils and Holding Registers), it's necessary to correctly set the user and the password in the corresponding Holding Registers (addresses 3483, 3844, 3485, 3486 and 3487). See Section 11 for details.

7.1 Discrete Inputs

In the Discrete Input Data Area, the Modbus RTU Interface implements the same 32 Discrete Inputs available on ICON2000v4 and ICON3000.

Status of Discrete Inputs is indicated as 1 = ON and 0 = OFF.

Table 1 shows the Discrete Inputs implemented in the Modbus RTU Interface:

Table 1.

ICON2000v4 legacy data block		
Input Status Number	Input Status Address	Description
1	0	Close Limit
2	1	Open Limit
3	2	Actuator Moving
4	3	Monitor Relay
5	4	Selector in LOCAL
6	5	Selector in REMOTE
7	6	Alarm
8	7	Warning
9	8	DIN1 (See Note 1)
10	9	DIN2 (See Note 1)
11	10	DIN3 (See Note 1)
12	11	DIN4 (See Note 1)
13	12	DIN5 (See Note 1)
14	13	DIN6 (See Note 1)
15	14	Interlock Open
16	15	Interlock Close
17	16	Fail-Safe Action
18	17	Actuator Opening
19	18	Actuator Closing
20	19	Selector in OFF
21	20	ESD/PST Control
22	21	Hardwired Remote Mode
23	22	Positioner Mode
24	23	Motor Operation Inhibited
25	24	Channel 1 Active
26	25	Hardwired Open Command
27	26	Hardwired Close Command
28	27	Hardwired Stop Command
29	28	Hardwired BUS-on
30	29	Base Card Communication Error (Reserved)
31	30	Reserved (always 0)
32	31	Reserved (always 0)

NOTE:**1. “DIN1”, “DIN2”, “DIN3”, “DIN4”, “DIN5”, “DIN6”:**

The bits DIN1, DIN2, DIN3, DIN4, DIN5, DIN6 can be individually configured to be set to “1” if one of the conditions defined in the HRs 3622, 3623, 3624, 3625, 3626, 3627 occurs. They can also be configured via local operator interface.

7.2 Coils

In the Coils Data Area, the Modbus RTU Interface implements the 11 coils.

Status of Coils is indicated as 1 = ON and 0 = OFF.

Table 2 shows the Coils implemented in the Modbus RTU Interface of ICON2000v4 and ICON3000. The “User Level” column indicates the “User Level Logged” required to write the correspondent Coil. See Section 11 for details about the writing rules of the Modbus data.

Table 2. ICON2000v4 and ICON3000 Coils

ICON2000v4 legacy data block		
Coil Number	Coil Address	Description
1	0	Open Command (See Notes 1 and 2)
2	1	Close Command (See Notes 1 and 2)
3	2	Stop Command (See Notes 1 and 2)
4	3	ESD/PST Command (See Notes 2, 3 and 5)
5	4	Positioner Mode (See Notes 2 and 4)
6	5	Reserved (always 0)
7	6	Reserved (always 0)
8	7	Reserved (always 0)
9	8	Reserved (always 0)
10	9	Reserved (always 0)
11	10	Reserved (always 0)

Table 3. ICON3000v2 Coils

ICON2000v4 legacy data block			
Coil Number	Coil Address	User Level	Description
1	0	USER	Open Command (See Notes 1 and 2)
2	1	USER	Close Command (See Notes 1 and 2)
3	2	USER	Stop Command (See Notes 1 and 2)
4	3	USER	ESD Command (See Notes 2 and 3)
5	4	USER	Positioner Mode (See Notes 2 and 4)
6	5	USER	PST Command (See Note 5)
7	6	-	Reserved
8	7	-	Reserved
9	8	-	Reserved
10	9	-	Reserved
11	10	-	Reserved

NOTE:**1. “Open Command”, “Close Command”, “Stop Command”:**

“Open” and “Close” commands are self-maintained.

If “Stop Command” is received, “Open command” and “Close command” are ignored. When “Stop Command” returns to 0, “Open command” and “Close command” can be carried out.

By using Function Code 05:

If “Open command” is active and “Close command” is received, the movement is reversed and “Open command” is cleared.

If “Close command” is active and “Open command” is received, the movement is reversed and “Close command” is cleared.

To clear “Open command” it’s necessary to set “Stop Command” to ON and to set “Open command” to OFF.

To clear “Close command” it’s necessary to set “Stop Command” to ON and to set “Close command” to OFF.

2. Open, Close, Stop, ESD commands and “Positioner mode”:

“Local Stop pressed”, “Selector in OFF”, “Selector in LOCAL” stops temporarily these commands; when the local STOP is depressed or the selector returns in REMOTE position, the previous command is restored.

3. “ESD Command”:

If the value is ON, an ESD command is generated. When the signal returns to OFF, the ESD command is cleared.

4. “Positioner Mode”:

“Positioner Mode” command is available only in modulating actuators.

If its value is ON, the positioner function is enabled, and the actuator will position according to the content of position request register (Holding Registers addresses 1 or 3007).

5. “PST Command”:

If the value is ON, the PST command is generated.

“Local Stop pressed” and “Selector in OFF” stops the PST command.

If the value is ON and the PST command has been already executed, to perform a new PST command the coil must be cleared and re-set to ON.

See Section 12 for details.

7.3 Analog Inputs

In the Analog Input Data Area, the Modbus RTU Interface implements the same 369 Input Registers available on ICON2000v4 and ICON3000.

Table 4 shows the Input Registers implemented in the Modbus RTU Interface.

Table 4.

ICON2000v4 legacy data block					
Input Register Number	Input Register Address	Description	Range Value	Eng. Unit	Notes
1	0	Actuator Position (0=0.0%, 1000=100.0%)	0 - 1000	%	10 = 1,0%
2	1	Output Torque	-100 - 100	%	Negative Value = Torque in opening direction Positive Value = Torque in closing direction
3	2	Warnings	0 - 65535	-	Bit Field: b15 = General Warning b14 = Not Used b13 = Not Used b12 = Not Used b11 = PST Error - PST Failed b10 = PST Error - Over Travel b9 = PST Error - Max T-RET (T2) b8 = PST Error - Max T-PST (T1) b7 = Wrong Stroke Limit b6 = Motor Current b5 = Maintenance Request b4 = Contactor Cycles b3 = Main Voltage b2 = Hi Temperature b1 = Hi Torque CL b0 = Hi Torque OP 1 = Active, 0 = Not Active
4	3	Alarms1	0 - 65535	-	Bit Field: b15 = Request Signal b14 = Lost Phase b13 = Low Battery b12 = Hardware Error b11 = Configuration Error b10 = K2 Contactor b9 = K1 Contactor b8 = Main Voltage b7 = Speed Sensor b6 = Position Sensor b5 = Hi-Hi Temperature b4 = Blocked CL b3 = Blocked OP b2 = Hi-Hi Torque CL b1 = Hi-Hi Torque OP b0 = Motor Thermostat 1 = Active, 0 = Not Active
5	4	Alarms2	0 - 65535	-	Bit Field: b15 = Hardware 10 b14 = Hardware 9 b13 = Hardware 8 b12 = Hardware 7 b11 = Hardware 6 b10 = Hardware 5 b9 = Hardware 4 b8 = Hardware 3 b7 = Hardware 2 b6 = Hardware 1 b5 = Mid Travel CL b4 = Mid Travel OP b3 = Direction Test Fail b2 = Jammed OP b1 = Jammed CL b0 = Max. Torque intermediate position

ICON2000v4 legacy data block					
Input Register Number	Input Register Address	Description	Range Value	Eng. Unit	Notes
6	5	Opening Time	0 - 65535	Seconds	-
7	6	Closing Time	0 - 65535	Seconds	-
8	7	General Log - Contactor Cycles (1/2)	0 - 65535	-	Unsigned 32, MSB. See Note 1
9	8	General Log - Contactor Cycles (2/2)	0 - 65535	-	Unsigned 32, LSB. See Note 1
10	9	General Log - Motor Run Time (1/2)	0 - 65535	Hours	Unsigned 32, MSB. See Note 1
11	10	General Log - Motor Run Time (2/2)	0 - 65535	Hours	Unsigned 32, LSB. See note 1
12	11	General Log - Time without electrical power (1/2)	0 - 65535	Hours	Unsigned 32, MSB. See note 1
13	12	General Log - Time without electrical power (2/2)	0 - 65535	Hours	Unsigned 32, LSB. See note 1
14	13	General Log - Utilization Rate	0 - 100	%	0=0%, 100=100%
15	14	Test Date (1/2)	-	-	BCD Format. See Note 2
16	15	Test Date (2/2)	-	-	BCD Format. See Note 2
17	16	Recent Log Date (1/2)	-	-	BCD Format. See Note 2
18	17	Recent Log Date (2/2)	-	-	BCD Format. See Note 2
19	18	Recent Log - Contactor Cycles (1/2)	0 - 65535	-	Unsigned 32, MSB. See Note 1
20	19	Recent Log - Contactor Cycles (2/2)	0 - 65535	-	Unsigned 32, LSB. See Note 1
21	20	Recent Log - Motor Run Time (1/2)	0 - 65535	Hours	Unsigned 32, MSB. See Note 1
22	21	Recent Log - Motor Run Time (2/2)	0 - 65535	Hours	Unsigned 32, LSB. See Note 1
23	22	Recent Log - Time without electrical power (1/2)	0 - 65535	Hours	Unsigned 32, MSB. See Note 1
24	23	Recent Log - Time without electrical power (2/2)	0 - 65535	Hours	Unsigned 32, LSB. See Note 1
25	24	Recent Log - Utilization Rate	0 - 100	%	0=0%, 100=100%
26	25	Last Torque profile in OP - Break Out	0 - 65535	-	-
27	26	Last Torque profile in OP - Peak	0 - 65535	-	-
28	27	Last Torque profile in OP - Ending	0 - 65535	-	-
29	28	Last torque profile in OP - Date (1/2)	-	-	BCD Format. See Note 2
30	29	Last torque profile in OP - Date (2/2)	-	-	BCD Format. See Note 2
31	30	Last Torque profile in CL - Break Out	0 - 65535	-	-
32	31	Last Torque profile in CL - Peak	0 - 65535	-	-
33	32	Last Torque profile in CL - Ending	0 - 65535	-	-
34	33	Last torque profile in CL - Date (1/2)	-	-	BCD Format. See Note 2
35	34	Last torque profile in CL - Date (2/2)	-	-	BCD Format. See Note 2

ICON2000v4 legacy data block					
Input Register Number	Input Register Address	Description	Range Value	Eng. Unit	Notes
36	35	Torque reference profile in OP - Break Out	0 - 65535	-	-
37	36	Torque reference profile in OP - Peak	0 - 65535	-	-
38	37	Torque reference profile in OP - Ending	0 - 65535	-	-
39	38	Torque reference profile in OP - Date (1/2)	-	-	BCD Format. See Note 2
40	39	Torque reference profile in OP - Date (2/2)	-	-	BCD Format. See Note 2
41	40	Torque reference profile in CL - Break Out	0 - 65535	-	-
42	41	Torque reference profile in CL - Peak	0 - 65535	-	-
43	42	Torque reference profile in CL - Ending	0 - 65535	-	-
44	43	Torque reference profile in CL - Date (1/2)	-	-	BCD Format. See Note 2
45	44	Torque reference profile in CL - Date (2/2)	-	-	BCD Format. See Note 2
46	45	Alarm Log 1 - Code	0 - 32	-	See Note 3
47	46	Alarm Log 1 - Date (1/2)	-	-	BCD Format. See Note 2
48	47	Alarm Log 1 - Date (2/2)	-	-	BCD Format. See Note 2
49	48	Alarm Log 1 - Time (1/2)	-	-	BCD Format. See Note 4
50	49	Alarm Log 1 - Time (2/2)	-	-	BCD Format. See Note 4
51	50	Alarm Log 2 - Code	0 - 32	-	See Note 3
52	51	Alarm Log 2 - Date (1/2)	-	-	BCD Format. See Note 2
53	52	Alarm Log 2 - Date (2/2)	-	-	BCD Format. See Note 2
54	53	Alarm Log 2 - Time (1/2)	-	-	BCD Format. See Note 4
55	54	Alarm Log 2 - Time (2/2)	-	-	BCD Format. See Note 4
56	55	Alarm Log 3 - Code	0 - 32	-	See Note 3
57	56	Alarm Log 3 - Date (1/2)	-	-	BCD Format. See Note 2
58	57	Alarm Log 3 - Date (2/2)	-	-	BCD Format. See Note 2
59	58	Alarm Log 3 - Time (1/2)	-	-	BCD Format. See Note 4
60	59	Alarm Log 3 - Time (2/2)	-	-	BCD Format. See Note 4
61	60	Alarm Log 4 - Code	0 - 32	-	See Note 3
62	61	Alarm Log 4 - Date (1/2)	-	-	BCD Format. See Note 2
63	62	Alarm Log 4 - Date (2/2)	-	-	BCD Format. See Note 2
64	63	Alarm Log 4 - Time (1/2)	-	-	BCD Format. See Note 4
65	64	Alarm Log 4 - Time (2/2)	-	-	BCD Format. See Note 4
66	65	Alarm Log 5 - Code	0 - 32	-	See Note 3
67	66	Alarm Log 5 - Date (1/2)	-	-	BCD Format. See Note 2
68	67	Alarm Log 5 - Date (2/2)	-	-	BCD Format. See Note 2
69	68	Alarm Log 5 - Time (1/2)	-	-	BCD Format. See Note 4
70	69	Alarm Log 5 - Time (2/2)	-	-	BCD Format. See Note 4
71	70	Warning Log 1 - Code	0 - 13	-	See Note 5
72	71	Warning Log 1 - Date (1/2)	-	-	BCD Format. See Note 2
73	72	Warning Log 1 - Date (2/2)	-	-	BCD Format. See Note 2
74	73	Warning Log 1 - Time (1/2)	-	-	BCD Format. See Note 4
75	74	Warning Log 1 - Time (2/2)	-	-	BCD Format. See Note 4
76	75	Warning Log 2 - Code	0 - 13	-	See Note 5
77	76	Warning Log 2 - Date (1/2)	-	-	BCD Format. See Note 2
78	77	Warning Log 2 - Date (2/2)	-	-	BCD Format. See Note 2

ICON2000v4 legacy data block					
Input Register Number	Input Register Address	Description	Range Value	Eng. Unit	Notes
79	78	Warning Log 2 - Time (1/2)	-	-	BCD Format. See Note 4
80	79	Warning Log 2 - Time (2/2)	-	-	BCD Format. See Note 4
81	80	Warning Log 3 - Code	0 - 13	-	See Note 5
82	81	Warning Log 3 - Date (1/2)	-	-	BCD Format. See Note 2
83	82	Warning Log 3 - Date (2/2)	-	-	BCD Format. See Note 2
84	83	Warning Log 3 - Time (1/2)	-	-	BCD Format. See Note 4
85	84	Warning Log 3 - Time (2/2)	-	-	BCD Format. See Note 4
86	85	Warning Log 4 - Code	0 - 13	-	See Note 5
87	86	Warning Log 4 - Date (1/2)	-	-	BCD Format. See Note 2
88	87	Warning Log 4 - Date (2/2)	-	-	BCD Format. See Note 2
89	88	Warning Log 4 - Time (1/2)	-	-	BCD Format. See Note 4
90	89	Warning Log 4 - Time (2/2)	-	-	BCD Format. See Note 4
91	90	Warning Log 5 - Code	0 - 13	-	See Note 5
92	91	Warning Log 5 - Date (1/2)	-	-	BCD Format. See Note 2
93	92	Warning Log 5 - Date (2/2)	-	-	BCD Format. See Note 2
94	93	Warning Log 5 - Time (1/2)	-	-	BCD Format. See Note 4
95	94	Warning Log 5 - Time (2/2)	-	-	BCD Format. See Note 4
96	95	Nominal torque/thrust (1/4)	-	-	See Note 6
97	96	Nominal torque/thrust (2/4)	-	-	See Note 6
98	97	Nominal torque/thrust (3/4)	-	-	See Note 6
99	98	Nominal torque/thrust (4/4)	-	-	See Note 6
100	99	Min. temperature of base card	-254	°C	-
101	100	Max. temperature of base card	-254	°C	-
102	101	Min. temperature of terminal board	-254	°C	-
103	102	Max. temperature of terminal board	-254	°C	-
104	103	Max. temperature of motor	-254	°C	-
105	104	Number of motor alarm	0 - 65535	-	-
106	105	Number of torque alarm	0 - 65535	-	-
107	106	Recent min. temperature of base card	-254	°C	-
108	107	Recent max. temperature of base card	-254	°C	-
109	108	Recent min. temperature of terminal board	-254	°C	-
110	109	Recent max. temperature of terminal board	-254	°C	-
111	110	Recent max. temperature of motor	-254	°C	-
112	111	Recent number of motor alarm	0 - 65535	-	-
113	112	Recent number of torque alarm	0 - 65535	-	-
114 - 177	113 - 176	Last Close Torque Curve	-	-	See Note 7
178 - 241	177 - 240	Reference Close Torque Curve	-	-	See Note 7
242 - 305	241 - 304	Last Open Torque Curve	-	-	See Note 7
306 - 369	305 - 368	Reference Open Torque Curve	-	-	See Note 7

NOTE:

1. “General Log - Contactor Cycles”, “Recent Log - Contactor Cycles”, “General Log - Motor Run Time”, “Recent Log - Motor Run Time”, “General Log - Time without electrical power”, “Recent Log - time without electrical power”:

These data are contained in two registers. The first register contains high order bits, the second contains the low order bits.

2. “Test Date”, “Recent Log Date”, “Last torque profile in OP - Date”, “Last torque profile in CL - Date”, “Torque reference profile in OP - Date”, “Torque reference profile in CL - Date”, “Alarm Log 1 - Date”, “Alarm Log 2 - Date”, “Alarm Log 3 - Date”, “Alarm Log 4 - Date”, “Alarm Log 5 - Date”, “Warning Log 1 - Date”, “Warning Log 2 - Date”, “Warning Log 3 - Date”, “Warning Log 4 - Date”, “Warning Log 5 - Date”:

These registers contain date data that are represented in BCD format. The first register contains the day (in the first byte) and the month (in the second byte); the second register contains the year.

Example: Test Date (Input Registers Address 14, 15)

Input Register 14 = 0x1210 → Day: 12, Month: 10 (October)

Input Register 15 = 0x2021 → Year: 2021

3. “Alarm Log 1 - Code”, “Alarm Log 2 - Code”, Alarm Log 3 - Code”, “Alarm Log 4 - Code”, “Alarm Log 5 - Code”:

Registers from address 45 to 49 contain data of the most recent alarm (Alarm Log 1);

Registers from address 50 to 54 contain data of the second recent alarm (Alarm Log 2);

Registers from address 55 to 59 contain data of the third recent alarm (Alarm Log 3);

Registers from address 60 to 64 contain data of the fourth recent alarm (Alarm Log 4);

Registers from address 65 to 69 contain data if the fifth recent alarm (Alarm Log 5).

“Alarm Log - Code” registers contain the alarm code; the data type is enumerated:

Value	Description
0	None
1	Configuration Error
2	Motor Thermostat
3	Hi-Hi Temperature
4	Low Battery
5	Hi-Hi Torque in close direction
6	Hi-Hi Torque in open direction
7	Valve Jammed in close
8	Valve Jammed in open
9	Position Sensor
10	Speed Sensor or Direction
11	Main Voltage
12	Lost Phase
13	K1 Contactor
14	K2 Contactor
15	Mid travel alarm in close
16	Mid travel alarm in open
17	Hardware 1
18	Request Signal
19	Direction Test
20	Hardware 2
21	Hardware 3
22	Hardware 4
23	Hardware 5
24	Hardware 6
25	Hardware 7
26	Hardware 8
27	Hardware 9
28	Hardware 10
29	EFS Mid Travel
30	Hardware 11
31	Hardware 12
32	Hardware 13

4. “Alarm Log 1 - Time”, “Alarm Log 2 - Time”, “Alarm Log 3 - Time”, “Alarm Log 4 - Time”, “Alarm Log 5 - Time”, “Warning Log 1 - Time”, “Warning Log 2 - Time”, “Warning Log 3 - Time”, “Warning Log 4 - Time”, “Warning Log 5 - Time”:

These registers contains time data that are represented in BCD format. The first register contains the hours (MSB byte is not used and fixed to 0, the LSB byte contains the hours); the second register contains the minutes (in the MSB byte) and the seconds (in the LSB byte).

Example: Alarm Log 1 - Time (Input Registers Addresses 48, 49)

Input Register 48 = 0x0017 → Hours: 17
Input Register 49 = 0x4239 → Minutes: 42, Seconds: 39

5. “Warning Log 1 - Code”, “Warning Log 2 - Code”, “Warning Log 3 - Code”, “Warning Log 4 - Code”, “Warning Log 5 - Code”:

Registers from address 65 to 69 contain data of the most recent warning;

Registers from address 70 to 74 contain data of the second recent warning;

Registers from address 75 to 79 contain data of the third recent warning;

Registers from address 80 to 84 contain data of the fourth recent warning;

Registers from address 85 to 89 contain data if the fifth recent warning.

“Warning Log - Code” registers contain the warning code; the data type is enumerated:

Value	Description
0	None
1	Hi Torque in opening
2	Hi Torque in closing
3	Hi Temperature
4	Main Supply
5	Max. Contactor Cycles
6	Maintenance Request
7	Motor Current
8	Wrong Stroke Limits
9	Bus
10	PST Failed
11	PST Failed - Max T1
12	PST Failed - Max T2
13	PST Failed - Over Travel

6. “Nominal Torque/Thrust”:

These registers contain two types of data. The first register (address 95) contains the torque/thrust engineering unit in the first byte (MSB) and an ASCII character in the second byte (LSB). Other registers contain ASCII character, one character for each byte.

The table below shows the engineering unit codes:

Value	Description
0	lbf
1	Nm
2	lb
3	KN

7. “Last Close Torque Curve”, “Reference Close Torque Curve”, “Last Open Torque Curve”, “Reference Open Torque Curve”:

These registers contain several types of data; the combination of this data is described, byte per byte, in the table below:

Byte	Description
1 st - 101 st	Torque Samples* (One sample for each byte)
102 nd	Date of torque curve (BCD format): Day
103 rd	Date of torque curve (BCD format): Month
104 th	Date of torque curve (BCD format): Year minus 2000
105 th	Time of torque curve (BCD format): seconds
106 th	Time of torque curve (BCD format): minutes
107 th	Time of torque curve (BCD format): hours
108 th	Electronic temperature (signed char, eng. unit: °C)
109 th	Terminal board temperature (signed char, eng. unit: °C)
110 th	Mot/speed temperature (signed char, eng. unit: °C)
111 th - 112 th	Voltage. First byte contains most significant bits. (eng. unit: V)
113 th - 114 th	Closing/Opening time. First byte contains most significant bits (eng. unit: seconds)
115 th - 128 th	Reserved data

Each register contains 2 bytes of torque curve data.

*The index of these bytes indicates the actuator position.

Example: index 1 indicates the output torque on the position 0%; index 2 indicates the output torque on the position 1%, and so on).

7.4 Holding Registers

In the Holding Register Data Area, the Modbus RTU Interface implements the same Holding Registers available on ICON2000v4, from Holding Register Number 23 to Holding Register Number 3474, the Holding Registers available on ICON3000 and, starting from Holding Register Number 3475, the new set of data.

For each register is declared the access in only reading (R) or in reading and writing (RW).

Table 5 shows the Holding Registers implemented in the Modbus RTU Interface.

If a register is writable, the “User Level” column indicates the “User Level Logged” required to modify it. See Section 11 for details about the writing rules of the Modbus data.

Table 5.

ICON2000v4 legacy data block							
Holding Register Number	Holding Register Address	Description	RW	Range Value	Eng. Unit	User Level	Notes
1	0	Actuator Commands	RW	0 - 6	-	USER	Enumerated: 0 = Clear Commands 1 = Close Command 2 = Open Command 3 = ESD Command 4 = Enable Positioner Mode 5 = PST Command 6 = Baseline PST Command See Note 1 for details
2	1	Position Request	RW	0 - 1000	%	USER	0=0.0%, 1000=100.0% See Section 9.2 for details
3	2	Dead Band	RW	1 - 255	%	USER	1=0.1%, 255=25.5% See Section 9.2 for details
4	3	Motion Inhibit Time	RW	1 - 255	Seconds	USER	See Section 9.2 for details
5	4	Reserved	R	-	-	OBSERVER	-
6	5	Reserved	R	-	-	OBSERVER	-
7	6	Reserved	R	-	-	OBSERVER	-
8	7	Fail-Safe Action	RW	0 - 4	-	USER	Enumerated: 0 = Off 1 = Close command 2 = Open command 3 = Stay put 4 = Go to xx% (xx% = HR “Fail-Safe Position”) See Section 9.3 for details
9	8	Fail-Safe Delay	RW	0 - 255	Seconds	USER	See Section 9.3 for details
10	9	Fail-Safe Position	RW	0 - 100	%	USER	0=0%, 100=100% See Section 9.3 for details
11	10	Reserved	R	-	-	OBSERVER	-
12	11	Next Maintenance Date (1/2)	RW	-	-	USER	BCD Format. See Note 2
13	12	Next Maintenance Date (2/2)	RW	-	-	USER	BCD Format. See Note 2
14	13	Last Maintenance Date (1/2)	RW	-	-	USER	BCD Format. See Note 2
15	14	Last Maintenance Date (2/2)	RW	-	-	USER	BCD Format. See Note 2
16	15	Current Date (1/2)	RW	-	-	USER	BCD Format. See Note 2
17	16	Current Date (2/2)	RW	-	-	USER	BCD Format. See Note 2
18	17	Current Time (1/2)	RW	-	-	USER	BCD Format. See Note 3
19	18	Current Time (2/2)	RW	-	-	USER	BCD Format. See Note 3
20	19	Start Up Date (1/2)	RW	-	-	USER	BCD Format. See Note 2
21	20	Start Up Date (2/2)	RW	-	-	USER	BCD Format. See Note 2
22	21	Modbus Channel Communication	RW	0 - 2	-	USER	Enumerated: 0 = CH1 Enabled, CH2 Disabled 1 = CH1 Disabled, CH2 Enabled 2 = CH1 Enabled, CH1 Enabled

ICON3000 legacy data block								
Holding Register Number	Holding Register Address	Description	RW	Range Value	Eng. Unit	User Level	Notes	
23 - 44	22 - 43	Reserved	R	-	-	OBSERVER	-	
45	44	Actuator ID	R	-	-	OBSERVER	Always 0x9000	
46	45	Compatibility Number	R	-	-	OBSERVER	Always 0x0001	
47 - 3000	46 - 2999	Reserved	R	-	-	OBSERVER	-	
3001	3000	ICON3000 Identifier	R	-	-	OBSERVER	Always 0x9000	
3002	3001	Actuator Status 1	R	0 - 65535	-	OBSERVER	Bit Field: b15 = Interlock CL b14 = Interlock OP b13 = DIN6 b12 = DIN5 b11 = DIN4 b10 = DIN3 b9 = DIN2 b8 = DIN1 b7 = Warning b6 = Alarm b5 = Selector in REMOTE b4 = Selector in LOCAL b3 = Monitor Relay b2 = Actuator Moving b1 = Open Limit b0 = Close Limit 1 = Active; 0 = Not Active	
3003	3002	Actuator Status 2	R	0 - 65535	-	OBSERVER	Bit Field: b15 = PST in progress b14 = ESD in progress b13 = Base Card Communication Error b12 = Hardwired Bus-On b11 = Hardwired Stop Command b10 = Hardwired Close Command b9 = Hardwired Open Command b8 = Channel1 Active b7 = Motor Operation Inhibited b6 = Positioner Mode b5 = Hardwired Remote Mode b4 = ESD/PST Control b3 = Selector in OFF b2 = Closing b1 = Opening b0 = Fail-Safe Action 1 = Active; 0 = Not Active	
3004	3003	Actuator Status 3	R	0 - 65535	-	OBSERVER	Bit Field: b15 = Manual Operation (Handwheel) b14 = Local Configuration b13 = Bus Open Travelling available b12 = Bus Close Travelling available b11 = Pos <= xx% (DIN1 Position) b10 = Pos >= yy% (DIN2 Position) b9 = Motor Temperature Enabled b8 = Channel2 Active b7 = Motor Thermostat Closed b6 = K2 Contactor Closed b5 = K1 Contactor Closed b4 = AS8 Relay Heater b3 = Terminal Board Heater b2 = Display-Logic Card Heater b1 = Last PST Passed b0 = Last PST Aborted 1 = Active; 0 = Not Active	
3005	3004	Actuator Position	R	0 - 1000	%	OBSERVER	0 = 0.0%, 1000 = 100.0%	

ICON3000 legacy data block							
Holding Register Number	Holding Register Address	Description	RW	Range Value	Eng. Unit	User Level	Notes
3006	3005	Output Torque	R	-100 - 100	%	OBSERVER	Negative Value = Torque in opening direction Positive Value = Torque in closing direction
3007	3006	Actuator Commands 1	RW	-	-	USER	Bit Field: b6 - b15 = Not Used b5 = PST Command b4 = Enable Positioner Mode b3 = ESD Command b2 = Stop Command b1 = Open Command b0 = Close Command See Note 4 for details
3008	3007	Position Request	RW	0 - 1000	%	USER	0=0.0%, 1000=100.0% See Section 9.2 for details
3009	3008	Actuator Commands 2	RW	0 - 6	-	USER	Enumerated: 0 = Clear Commands 1 = Close Command 2 = Open Command 3 = ESD Command 4 = Enable Positioner Mode 5 = PST Command 6 = Baseline PST Command See Note 1 for details
3010	3009	Warnings	R	0 - 65535	-	OBSERVER	Bit Field: b15 = General Warning b14 = Not Used b13 = Not Used b12 = Not Used b11 = PST Error - PST Failed b10 = PST Error - Over Travel b9 = PST Error - Max T-RET (T2) b8 = PST Error - Max T-PST (T1) b7 = Wrong Stroke Limit b6 = Motor Current b5 = Maintenance Request b4 = Contactor Cycles b3 = Main Voltage b2 = Hi Temperature b1 = Hi Torque CL b0 = Hi Torque OP 1 = Active, 0 = Not Active
3011	3010	Alarms 1	R	0 - 65535	-	OBSERVER	Bit Field: b15 = Request Signal b14 = Lost Phase b13 = Low Battery b12 = Hardware Error b11 = Configuration Error b10 = K2 Contactor b9 = K1 Contactor b8 = Main Voltage b7 = Speed Sensor b6 = Position Sensor b5 = Hi-Hi Temperature b4 = Blocked CL b3 = Blocked OP b2 = Hi-Hi Torque CL b1 = Hi-Hi Torque OP b0 = Motor Thermostat 1 = Active, 0 = Not Active

ICON3000 legacy data block							
Holding Register Number	Holding Register Address	Description	RW	Range Value	Eng. Unit	User Level	Notes
3012	3011	Alarms 2	R	0 - 65535	-	OBSERVER	Bit Field: b15 = Hardware 10 b14 = Hardware 9 b13 = Hardware 8 b12 = Hardware 7 b11 = Hardware 6 b10 = Hardware 5 b9 = Hardware 4 b8 = Hardware 3 b7 = Hardware 2 b6 = Hardware 1 b5 = Mid Travel CL b4 = Mid Travel OP b3 = Direction Test Fail b2 = Jammed OP b1 = Jammed CL b0 = Max. Torque intermediate position 1 = Active, 0 = Not Active
3013	3012	Aux. Analog Input mA	R	0 - 65535	mA	OBSERVER	1 = 0.01 mA
3014	3013	Aux. Analog Input 12 bit	R	0 - 4095	-	OBSERVER	1 = 0.024% (See Note 5)
3015	3014	Clear Alarms and Warnings Log	RW	0 - 1	-	USER	See Note 6
3016	3015	Reset Alarms and Warnings	RW	0 - 1	-	USER	See Note 7
3017	3016	Alarms 3	R	0 - 65535	-	OBSERVER	Bit Field: b4 - b15 = Not Used b3 = Hardware 13 b2 = Hardware 12 b1 = Hardware 11 b0 = EFS Mid Travel
3018	3017	Dead Band	RW	1 - 255	%	USER	1=0.1%, 255=25.5% See Section 9.2 for details
3019	3018	Motion Inhibit Time	RW	1 - 255	Seconds	USER	See Section 9.2 for details
3020	3019	Fail-Safe Action	RW	0 - 4	-	USER	Enumerated: 0 = Off 1 = Close command 2 = Open command 3 = Stay put 4 = Go to xx% (xx% = HR "Fail-Safe Position") See Section 9.3 for details
3021	3020	Fail-Safe Delay	RW	0 - 255	Seconds	USER	See Section 9.3 for details
3022	3021	Fail-Safe Position	RW	0 - 100	%	USER	0=0%, 100=100% See Section 9.3 for details
3023	3022	Channel mode	RW	0 - 2	-	USER	Enumerated: 0 = CH1 Enabled, CH2 Disabled 1 = CH1 Disabled, CH2 Enabled 2 = CH1 Enabled, CH1 Enabled
3024	3023	Current Date (1/2)	RW	-	-	USER	BCD Format. See Note 2
3025	3024	Current Date (2/2)	RW	-	-	USER	BCD Format. See Note 2
3026	3025	Current Time (1/2)	RW	-	-	USER	BCD Format. See Note 3
3027	3026	Current Time (2/2)	RW	-	-	USER	BCD Format. See Note 3
3028	3027	Interlock Mode	R	0 - 1	-	SERVICE	Enumerated: 0 = Standard 1 = Advanced See Section 11 for details
3029	3028	EFS Input Mode	R	0 - 1	-	USER	ESD Input Mode: 0 = PST-EFS 1 = EFS See Section 11 for details
3030	3029	Fail-Safe and Interlock Commands	RW	-	-	USER	Bit Field: b3 - b15 = Not Used b2 = Fail-Safe Command b1 = Interlock Close Command b0 = Interlock Open Command 1 = Active, 0 = Not Active

ICON3000 legacy data block							
Holding Register Number	Holding Register Address	Description	RW	Range Value	Eng. Unit	User Level	Notes
3031	3030	Actuator Status 4	R	-	-	OBSERVER	Bit Field: b2 - b 15 = Not Used b1 = Remote Stop b0 = Maintenance Operation 1 = Active, 0 = Not Active
3032	3031	Spare - Not Used	R	-	-	OBSERVER	-
3033	3032	Spare - Not Used	R	-	-	OBSERVER	-
3034	3033	Spare - Not Used	R	-	-	OBSERVER	-
3035	3034	Actuator Identifier (1/8)	R	-	-	OBSERVER	ASCII, MSB
3036	3035	Actuator Identifier (2/8)	R	-	-	OBSERVER	ASCII
3037	3036	Actuator Identifier (3/8)	R	-	-	OBSERVER	ASCII
3038	3037	Actuator Identifier (4/8)	R	-	-	OBSERVER	ASCII
3039	3038	Actuator Identifier (5/8)	R	-	-	OBSERVER	ASCII
3040	3039	Actuator Identifier (6/8)	R	-	-	OBSERVER	ASCII
3041	3040	Actuator Identifier (7/8)	R	-	-	OBSERVER	ASCII
3042	3041	Actuator Identifier (8/8)	R	-	-	OBSERVER	ASCII, LSB
3043	3042	Actuator Serial Number (1/14)	R	-	-	OBSERVER	ASCII, MSB
3044	3043	Actuator Serial Number (2/14)	R	-	-	OBSERVER	ASCII
3045	3044	Actuator Serial Number (3/14)	R	-	-	OBSERVER	ASCII
3046	3045	Actuator Serial Number (4/14)	R	-	-	OBSERVER	ASCII
3047	3046	Actuator Serial Number (5/14)	R	-	-	OBSERVER	ASCII
3048	3047	Actuator Serial Number (6/14)	R	-	-	OBSERVER	ASCII
3049	3048	Actuator Serial Number (7/14)	R	-	-	OBSERVER	ASCII
3050	3049	Actuator Serial Number (8/14)	R	-	-	OBSERVER	ASCII
3051	3050	Actuator Serial Number (9/14)	R	-	-	OBSERVER	ASCII
3052	3051	Actuator Serial Number (10/14)	R	-	-	OBSERVER	ASCII
3053	3052	Actuator Serial Number (11/14)	R	-	-	OBSERVER	ASCII
3054	3053	Actuator Serial Number (12/14)	R	-	-	OBSERVER	ASCII
3055	3054	Actuator Serial Number (13/14)	R	-	-	OBSERVER	ASCII
3056	3055	Actuator Serial Number (14/14)	R	-	-	OBSERVER	ASCII, LSB
3057	3056	Valve Tag Name (1/14)	RW	-	-	USER	ASCII, MSB
3058	3057	Valve Tag Name (2/14)	RW	-	-	USER	ASCII
3059	3058	Valve Tag Name (3/14)	RW	-	-	USER	ASCII
3060	3059	Valve Tag Name (4/14)	RW	-	-	USER	ASCII
3061	3060	Valve Tag Name (5/14)	RW	-	-	USER	ASCII
3062	3061	Valve Tag Name (6/14)	RW	-	-	USER	ASCII

ICON3000 legacy data block							
Holding Register Number	Holding Register Address	Description	RW	Range Value	Eng. Unit	User Level	Notes
3063	3062	Valve Tag Name (7/14)	RW	-	-	USER	ASCII
3064	3063	Valve Tag Name (8/14)	RW	-	-	USER	ASCII
3065	3064	Valve Tag Name (9/14)	RW	-	-	USER	ASCII
3066	3065	Valve Tag Name (10/14)	RW	-	-	USER	ASCII
3067	3066	Valve Tag Name (11/14)	RW	-	-	USER	ASCII
3068	3067	Valve Tag Name (12/14)	RW	-	-	USER	ASCII
3069	3068	Valve Tag Name (13/14)	RW	-	-	USER	ASCII
3070	3069	Valve Tag Name (14/14)	RW	-	-	USER	ASCII, LSB
3071	3070	Base Card SW Version (1/2)	R	-	-	OBSERVER	ASCII, MSB
3072	3071	Base Card SW Version (2/2)	R	-	-	OBSERVER	ASCII, LSB
3073	3072	Modbus Interface SW Version (1/2)	R	-	-	OBSERVER	ASCII, MSB
3074	3073	Modbus Interface SW Version (2/2)	R	-	-	OBSERVER	ASCII, LSB
3075	3074	Nominal Torque/Thrust	R	-	-	OBSERVER	See Note 8
3076	3075	Nominal Torque/Thrust	R	-	-	OBSERVER	See Note 8
3077	3076	Nominal Torque/Thrust	R	-	-	OBSERVER	See Note 8
3078	3077	Nominal Torque/Thrust	R	-	-	OBSERVER	See Note 8
3079	3078	Test Date (1/2)	R	-	-	OBSERVER	BCD Format. See Note 2
3080	3079	Test Date (2/2)	R	-	-	OBSERVER	BCD Format. See Note 2
3081	3080	Spare - Not Used	R	-	-	OBSERVER	-
3082	3081	Spare - Not Used	R	-	-	OBSERVER	-
3083	3082	Start Up Date (1/2)	RW	-	-	USER	BCD Format. See Note 2
3084	3083	Start Up Date (2/2)	RW	-	-	USER	BCD Format. See Note 2
3085	3084	Next Maintenance Date (1/2)	RW	-	-	USER	BCD Format. See Note 2
3086	3085	Next Maintenance Date (2/2)	RW	-	-	USER	BCD Format. See Note 2
3087	3086	Last Maintenance Date (1/2)	RW	-	-	USER	BCD Format. See Note 2
3088	3087	Last Maintenance Date (2/2)	RW	-	-	USER	BCD Format. See Note 2
3089	3088	Recent Log Date (1/2)	R	-	-	OBSERVER	BCD Format. See Note 2
3090	3089	Recent Log Date (2/2)	R	-	-	OBSERVER	BCD Format. See Note 2
3091	3090	Alarm Log 1 - Code	R	0 - 32	-	OBSERVER	See Note 9
3092	3091	Alarm Log 1 - Date (1/2)	R	-	-	OBSERVER	BCD Format. See Note 2
3093	3092	Alarm Log 1 - Date (2/2)	R	-	-	OBSERVER	BCD Format. See Note 2
3094	3093	Alarm Log 1 - Time (1/2)	R	-	-	OBSERVER	BCD Format. See Note 3
3095	3094	Alarm Log 1 - Time (2/2)	R	-	-	OBSERVER	BCD Format. See Note 3
3096	3095	Alarm Log 2 - Code	R	0 - 32	-	OBSERVER	See Note 9
3097	3096	Alarm Log 2 - Date (1/2)	R	-	-	OBSERVER	BCD Format. See Note 2
3098	3097	Alarm Log 2 - Date (2/2)	R	-	-	OBSERVER	BCD Format. See Note 2
3099	3098	Alarm Log 2 - Time (1/2)	R	-	-	OBSERVER	BCD Format. See Note 3
3100	3099	Alarm Log 2 - Time (2/2)	R	-	-	OBSERVER	BCD Format. See Note 3
3101	3100	Alarm Log 3 - Code	R	0 - 32	-	OBSERVER	See Note 9
3102	3101	Alarm Log 3 - Date (1/2)	R	-	-	OBSERVER	BCD Format. See Note 2
3103	3102	Alarm Log 3 - Date (2/2)	R	-	-	OBSERVER	BCD Format. See Note 2
3104	3103	Alarm Log 3 - Time (1/2)	R	-	-	OBSERVER	BCD Format. See Note 3
3105	3104	Alarm Log 3 - Time (2/2)	R	-	-	OBSERVER	BCD Format. See Note 3
3106	3105	Alarm Log 4 - Code	R	0 - 32	-	OBSERVER	See Note 9
3107	3106	Alarm Log 4 - Date (1/2)	R	-	-	OBSERVER	BCD Format. See Note 2
3108	3107	Alarm Log 4 - Date (2/2)	R	-	-	OBSERVER	BCD Format. See Note 2
3109	3108	Alarm Log 4 - Time (1/2)	R	-	-	OBSERVER	BCD Format. See Note 3
3110	3109	Alarm Log 4 - Time (2/2)	R	-	-	OBSERVER	BCD Format. See Note 3
3111	3110	Alarm Log 5 - Code	R	0 - 32	-	OBSERVER	See Note 10
3112	3111	Alarm Log 5 - Date (1/2)	R	-	-	OBSERVER	BCD Format. See Note 2
3113	3112	Alarm Log 5 - Date (2/2)	R	-	-	OBSERVER	BCD Format. See Note 2

ICON3000 legacy data block							
Holding Register Number	Holding Register Address	Description	RW	Range Value	Eng. Unit	User Level	Notes
3114	3113	Alarm Log 5 - Time (1/2)	R	-	-	OBSERVER	BCD Format. See Note 3
3115	3114	Alarm Log 5 - Time (2/2)	R	-	-	OBSERVER	BCD Format. See Note 3
3116	3115	Warning Log 1 - Code	R	0 - 13	-	OBSERVER	See Note 10
3117	3116	Warning Log 1 - Date (1/2)	R	-	-	OBSERVER	BCD Format. See Note 2
3118	3117	Warning Log 1 - Date (2/2)	R	-	-	OBSERVER	BCD Format. See Note 2
3119	3118	Warning Log 1 - Time (1/2)	R	-	-	OBSERVER	BCD Format. See Note 3
3120	3119	Warning Log 1 - Time (2/2)	R	-	-	OBSERVER	BCD Format. See Note 3
3121	3120	Warning Log 2 - Code	R	0 - 13	-	OBSERVER	See Note 10
3122	3121	Warning Log 2 - Date (1/2)	R	-	-	OBSERVER	BCD Format. See Note 2
3123	3122	Warning Log 2 - Date (2/2)	R	-	-	OBSERVER	BCD Format. See Note 2
3124	3123	Warning Log 2 - Time (1/2)	R	-	-	OBSERVER	BCD Format. See Note 3
3125	3124	Warning Log 2 - Time (2/2)	R	-	-	OBSERVER	BCD Format. See Note 3
3126	3125	Warning Log 3 - Code	R	0 - 13	-	OBSERVER	See Note 10
3127	3126	Warning Log 3 - Date (1/2)	R	-	-	OBSERVER	BCD Format. See Note 2
3128	3127	Warning Log 3 - Date (2/2)	R	-	-	OBSERVER	BCD Format. See Note 2
3129	3128	Warning Log 3 - Time (1/2)	R	-	-	OBSERVER	BCD Format. See Note 3
3130	3129	Warning Log 3 - Time (2/2)	R	-	-	OBSERVER	BCD Format. See Note 3
3131	3130	Warning Log 4 - Code	R	0 - 13	-	OBSERVER	See Note 10
3132	3131	Warning Log 4 - Date (1/2)	R	-	-	OBSERVER	BCD Format. See Note 2
3133	3132	Warning Log 4 - Date (2/2)	R	-	-	OBSERVER	BCD Format. See Note 2
3134	3133	Warning Log 4 - Time (1/2)	R	-	-	OBSERVER	BCD Format. See Note 3
3135	3134	Warning Log 4 - Time (2/2)	R	-	-	OBSERVER	BCD Format. See Note 3
3136	3135	Warning Log 5 - Code	R	0 - 13	-	OBSERVER	See Note 10
3137	3136	Warning Log 5 - Date (1/2)	R	-	-	OBSERVER	BCD Format. See Note 2
3138	3137	Warning Log 5 - Date (2/2)	R	-	-	OBSERVER	BCD Format. See Note 2
3139	3138	Warning Log 5 - Time (1/2)	R	-	-	OBSERVER	BCD Format. See Note 3
3140	3139	Warning Log 5 - Time (2/2)	R	-	-	OBSERVER	BCD Format. See Note 3
3141	3140	Spare - Not Used	R	-	-	OBSERVER	-
3142	3141	Spare - Not Used	R	-	-	OBSERVER	-
3143	3142	Spare - Not Used	R	-	-	OBSERVER	-
3144	3143	Spare - Not Used	R	-	-	OBSERVER	-
3145	3144	Spare - Not Used	R	-	-	OBSERVER	-
3146	3145	Opening Time	R	0 - 65535	Seconds	OBSERVER	-
3147	3146	Closing Time	R	0 - 65535	Seconds	OBSERVER	-
3148	3147	General Log - Contactor Cycles (1/2)	R	0 - 65535	-	OBSERVER	Unsigned 32, MSB. See Note 11
3149	3148	General Log - Contactor Cycles (2/2)	R	0 - 65535	-	OBSERVER	Unsigned 32, LSB. See Note 11
3150	3149	General Log - Motor Run Time (1/2)	R	0 - 65535	Hours	OBSERVER	Unsigned 32, MSB. See Note 11
3151	3150	General Log - Motor Run Time (2/2)	R	0 - 65535	Hours	OBSERVER	Unsigned 32, LSB. See Note 11
3152	3151	General Log - Time without electrical power (1/2)	R	0 - 65535	Hours	OBSERVER	Unsigned 32, MSB. See Note 11
3153	3152	General Log - Time without electrical power (2/2)	R	0 - 65535	Hours	OBSERVER	Unsigned 32, LSB. See Note 11
3154	3153	General Log - Utilization Rate	R	0 - 100	%	OBSERVER	0=0%, 100=100%
3155	3154	Recent Log - Contactor Cycles (1/2)	R	0 - 65535	-	OBSERVER	Unsigned 32, MSB. See Note 11
3156	3155	Recent Log - Contactor Cycles (2/2)	R	0 - 65535	-	OBSERVER	Unsigned 32, LSB. See Note 11
3157	3156	Recent Log - Motor Run Time (1/2)	R	0 - 65535	Hours	OBSERVER	Unsigned 32, MSB. See Note 11
3158	3157	Recent Log - Motor Run Time (2/2)	R	0 - 65535	Hours	OBSERVER	Unsigned 32, LSB. See Note 11
3159	3158	Recent Log - Time without electrical power (1/2)	R	0 - 65535	Hours	OBSERVER	Unsigned 32, MSB. See Note 11
3160	3159	Recent Log - Time without electrical power (2/2)	R	0 - 65535	Hours	OBSERVER	Unsigned 32, LSB. See Note 11

ICON3000 legacy data block								
Holding Register Number	Holding Register Address	Description	RW	Range Value	Eng. Unit	User Level	Notes	
3161	3160	Recent Log - Utilization Rate	R	0 - 100	%	OBSERVER	0=0%, 100=100%	
3162	3161	General Log - Min. temperature of base card	R	-127 - 127	°C	OBSERVER	-	
3163	3162	General Log - Max. temperature of base card	R	-127 - 127	°C	OBSERVER	-	
3164	3163	General Log - Min. temperature of terminal board	R	-127 - 127	°C	OBSERVER	-	
3165	3164	General Log - Max. temperature of terminal board	R	-127 - 127	°C	OBSERVER	-	
3166	3165	General Log - Max. temperature of motor	R	-127 - 127	°C	OBSERVER	-	
3167	3166	General Log - Number of motor alarm	R	0 - 65535	-	OBSERVER	-	
3168	3167	General Log - Number of torque alarm	R	0 - 65535	-	OBSERVER	-	
3169	3168	Recent Log - Min. temperature of base card (°C)	R	-127 - 127	°C	OBSERVER	-	
3170	3169	Recent Log - Max. temperature of base card (°C)	R	-127 - 127	°C	OBSERVER	-	
3171	3170	Recent Log - Min. temperature of terminal board (°C)	R	-127 - 127	°C	OBSERVER	-	
3172	3171	Recent Log - Max. temperature of terminal board (°C)	R	-127 - 127	°C	OBSERVER	-	
3173	3172	Recent Log - Max. temperature of motor (°C)	R	-127 - 127	°C	OBSERVER	-	
3174	3173	Recent Log - Number of motor alarm	R	0 - 65535	-	OBSERVER	-	
3175	3174	Recent Log - Number of torque alarm	R	0 - 65535	-	OBSERVER	-	
3176	3175	Spare - Not Used	R	-	-	OBSERVER	-	
3177	3176	Spare - Not Used	R	-	-	OBSERVER	-	
3178	3177	Spare - Not Used	R	-	-	OBSERVER	-	
3179	3178	Spare - Not Used	R	-	-	OBSERVER	-	
3180	3179	Spare - Not Used	R	-	-	OBSERVER	-	
3181	3180	Last Torque profile in OP - Break Out	R	0 - 65535	-	OBSERVER	-	
3182	3181	Last Torque profile in OP - Peak	R	0 - 65535	-	OBSERVER	-	
3183	3182	Last Torque profile in OP - Ending	R	0 - 65535	-	OBSERVER	-	
3184	3183	Last Torque Profile in OP - Date (1/2)	R	-	-	OBSERVER	BCD Format. See Note 2	
3185	3184	Last Torque profile in OP - Date (2/2)	R	-	-	OBSERVER	BCD Format. See Note 2	
3186	3185	Last Torque profile in CL - Break Out	R	0 - 65535	-	OBSERVER	-	
3187	3186	Last Torque profile in CL - Peak	R	0 - 65535	-	OBSERVER	-	
3188	3187	Last Torque profile in CL - Ending	R	0 - 65535	-	OBSERVER	-	
3189	3188	Last Torque profile in CL - Date (1/2)	R	-	-	OBSERVER	BCD Format. See Note 2	
3190	3189	Last Torque profile in CL - Date (2/2)	R	-	-	OBSERVER	BCD Format. See Note 2	
3191	3190	Torque reference profile in OP - Break Out	R	0 - 65535	-	OBSERVER	-	
3192	3191	Torque reference profile in OP - Peak	R	0 - 65535	-	OBSERVER	-	
3193	3192	Torque reference profile in OP - Ending	R	0 - 65535	-	OBSERVER	-	
3194	3193	Torque reference profile in OP - Date (1/2)	R	-	-	OBSERVER	BCD Format. See Note 2	
3195	3194	Torque reference profile in OP - Date (2/2)	R	-	-	OBSERVER	BCD Format. See Note 2	
3196	3195	Torque reference profile in CL - Break Out	R	0 - 65535	-	OBSERVER	-	
3197	3196	Torque reference profile in CL - Peak	R	0 - 65535	-	OBSERVER	-	
3198	3197	Torque reference profile in CL - Ending	R	0 - 65535	-	OBSERVER	-	

ICON3000 legacy data block								
Holding Register Number	Holding Register Address	Description	RW	Range Value	Eng. Unit	User Level	Notes	
3199	3198	Torque reference profile in CL - Date (1/2)	R	-	-	OBSERVER	BCD Format. See Note 2	
3200	3199	Torque reference profile in CL - Date (2/2)	R	-	-	OBSERVER	BCD Format. See Note 2	
3201 - 3264	3200 - 3263	Last Close Torque Curve	R	-	-	OBSERVER	See Note 12	
3265 - 3328	3264 - 3327	Reference Close Torque Curve	R	-	-	OBSERVER	See Note 12	
3329 - 3392	3328 - 3391	Last Open Torque Curve	R	-	-	OBSERVER	See Note 12	
3393 - 3456	3392 - 3455	Reference Open Torque Curve	R	-	-	OBSERVER	See Note 12	
3457	3456	Reserved	R	-	-	OBSERVER	-	
3458	3457	Reserved	R	-	-	OBSERVER	-	
3459	3458	Reserved	R	-	-	OBSERVER	-	
3460	3459	Spare - Not Used	R	-	-	OBSERVER	-	
3461	3460	Actuator Type (1/14)	R	-	-	SERVICE	ASCII, MSB. See Note 16	
3462	3461	Actuator Type (2/14)	R	-	-	SERVICE	ASCII. See Note 16	
3463	3462	Actuator Type (3/14)	R	-	-	SERVICE	ASCII. See Note 16	
3464	3463	Actuator Type (4/14)	R	-	-	SERVICE	ASCII. See Note 16	
3465	3464	Actuator Type (5/14)	R	-	-	SERVICE	ASCII. See Note 16	
3466	3465	Actuator Type (6/14)	R	-	-	SERVICE	ASCII. See Note 16	
3467	3466	Actuator Type (7/14)	R	-	-	SERVICE	ASCII. See Note 16	
3468	3467	Actuator Type (8/14)	R	-	-	SERVICE	ASCII. See Note 16	
3469	3468	Actuator Type (9/14)	R	-	-	SERVICE	ASCII. See Note 16	
3470	3469	Actuator Type (10/14)	R	-	-	SERVICE	ASCII. See Note 16	
3471	3470	Actuator Type (11/14)	R	-	-	SERVICE	ASCII. See Note 16	
3472	3471	Actuator Type (12/14)	R	-	-	SERVICE	ASCII. See Note 16	
3473	3472	Actuator Type (13/14)	R	-	-	SERVICE	ASCII. See Note 16	
3474	3473	Actuator Type (14/14)	R	-	-	SERVICE	ASCII, LSB. See Note 16	
ICON3000v2 legacy data block								
Holding Register Number	Holding Register Address	Description	RW	Range Value	Eng. Unit	User Level	Notes	
3475 - 3480	3474 - 3479	Reserved	R	-	-	OBSERVER	-	
3481	3480	User level logged	R	0 - 3	-	OBSERVER	Enumerated: 3 = Manufacturer 2 = Service 1 = User 0 = Observer	
3482	3481	Reserved	R	-	-	OBSERVER	-	
3483	3482	User Level	RW	0 - 3	-	OBSERVER	Enumerated: 3 = Manufacturer 2 = Service 1 = User 0 = Observer	
3484	3483	User Password (1/4)	RW	-	-	OBSERVER	ASCII, MSB. See Note 13	
3485	3484	User Password (2/4)	RW	-	-	OBSERVER	ASCII. See Note 13	
3486	3485	User Password (3/4)	RW	-	-	OBSERVER	ASCII. See Note 13	
3487	3486	User Password (4/4)	RW	-	-	OBSERVER	ASCII, LSB. See Note 13	
3488 - 3500	3487 - 3499	Reserved	R	-	-	OBSERVER	-	

ICON3000v2 legacy data block							
Holding Register Number	Holding Register Address	Description	RW	Range Value	Eng. Unit	User Level	Notes
3501	3500	Output Contacts Status	R	-	-	OBSERVER	Bit Field: b9 - b15 = Not Used b8 = Monitor Relay Status b7 = AS8 Status b6 = AS7 Status b5 = AS6 Status b4 = AS5 Status b3 = AS4 Status b2 = AS3 Status b1 = AS2 Status b0 = AS1 Status 1 = Contact Closed, 0 = Contact Open
3502	3501	Digital Inputs Status	R	-	-	OBSERVER	Bit Field: b7 - b15 = Not Used b6 = ESD b5 = Interlock Open b4 = Interlock Close b3 = Auto/Man b2 = Hardwired Stop Command b1 = Hardwired Close Command b0 = Hardwired Open Command 1 = High, 0 = Low
3503	3502	Motor Speed	R	0 - 4000	rpm	OBSERVER	-
3504	3503	Main Voltage	R	0 - 1000	V	OBSERVER	-
3505	3504	Current	R	0 - 1200	A	OBSERVER	15 = 1.5 A
3506	3505	Temperature	R	-40 - 125	°C	OBSERVER	-
3507	3506	Motor Temperature	R	-40 - 140	°C	OBSERVER	-
3508	3507	Terminal Board Temperature	R	-55 - 125	°C	OBSERVER	-
3509	3508	Analog Output mA	R	0 - 3000	mA	OBSERVER	1000 = 10.00 mA
3510	3509	Analog Output bit	R	0 - 4095	-	OBSERVER	-
3511	3510	Position Request for Logic Card	R	-300 - 1300	%	OBSERVER	100 = 10,0%
3512	3511	FST Open Curves Stored	R	0 - 100	-	OBSERVER	-
3513	3512	FST Close Curves Stored	R	0 - 100	-	OBSERVER	-
3514	3513	PST Curves Stored	R	0 - 16	-	OBSERVER	-
3515	3514	EFS Curves Stored	R	0 - 16	-	OBSERVER	-
3516	3515	PST Progress Counter	R	0 - 100	%	OBSERVER	10 = 10%
3517	3516	Last PST Status	R	-	-	OBSERVER	Bit Field: b5 - b15 = Not Used b4 = Reset b3 = Failed - Over Travel b2 = Failed - T-RET (T2) b1 = Failed - T-PST (T1) b0 = Passed 1 = Active, 0 = Not Active
3518	3517	Last PST Reset Conditions (1/2)	R	-	-	OBSERVER	Bit Field: b2 - b15 = Not Used b1 = EFS Mid Travel (EFS Only) b0 = Hardware Alarm 1 = Active, 0 = Not Active
3519	3518	Last PST Reset Conditions (2/2)	R	-	-	OBSERVER	Bit Field: b15 = K2 Contactor Alarm b14 = K1 Contactor Alarm b13 = Speed Sensor Alarm b12 = Hi Torque Alarm b11 = Jammed Valve Alarm b10 = Hi Temperature Alarm b9 = Lost Phase Alarm b8 = Main Supply Alarm b7 = Thermostat Alarm b6 = Position Sensor Alarm b5 = Configuration Alarm b4 = Fail-Safe b3 = ESD b2 = Remote Stop b1 = Local Stop b0 = Selector in OFF 1 = Active, 0 = Not Active

ICON3000v2 legacy data block							
Holding Register Number	Holding Register Address	Description	RW	Range Value	Eng. Unit	User Level	Notes
3520	3519	Encoder Absolute Position (1/2)	R	-	-	OBSERVER	Unsigned 32, MSB. See Note 11
3521	3520	Encoder Absolute Position (2/2)	R	-	-	OBSERVER	Unsigned 32, LSB. See Note 11
3522	3521	Encoder Status	R	-	-	OBSERVER	Bit Field: b10 - b15 = Not Used b9 = CW/CCW Not updated b8 = Encoder Communication Interrupted b7 = Calibrated (0 = Not calibrated) b1 - b6 = Not Used b0 = CCW (0 = CW)
3523	3522	Encoder Wheel 1 Value	R	0 - 2047	-	OBSERVER	-
3524	3523	Encoder Wheel 2 Value	R	0 - 2047	-	OBSERVER	-
3525	3524	Encoder Wheel 3 Value	R	0 - 2047	-	OBSERVER	-
3526	3525	Encoder Communication Errors Counter	R	0 - 65535	-	OBSERVER	-
3527	3526	Bus Communication Errors Counter	R	0 - 65535	-	OBSERVER	-
3528	3527	Terminal Board Errors Counter	R	0 - 65535	-	OBSERVER	-
3529	3528	Torque Potentiometer	R	0 - 4095	-	OBSERVER	-
3530	3529	Battery Voltage	R	0 - 159	V	OBSERVER	90 = 9.0 V
3531	3530	Modbus Interface Status	R	-	-	OBSERVER	Bit Field: b6 - b15 = Not Used b5 = Baud Rate Found on CH2 (only if Autobaud is active) b4 = Baud Rate Found on CH1 (only if Autobaud is active) b3 = Baud Rate Searching on CH2 b2 = Baud Rate Searching on CH1 b1 = CH2 Communication Active b0 = CH1 Communication Active 1 = Active, 0 = Not Active
3532	3531	Modbus CH1 - Bus message counter	R	0 - 65535	-	OBSERVER	-
3533	3532	Modbus CH1 - Slave message counter	R	0 - 65535	-	OBSERVER	-
3534	3533	Modbus CH1 - Bus communication error counter	R	0 - 65535	-	OBSERVER	-
3535	3534	Modbus CH1 - Bus exception error counter	R	0 - 65535	-	OBSERVER	-
3536	3535	Modbus CH1 - Slave busy counter	R	0 - 65535	-	OBSERVER	-
3537	3536	Modbus CH1 - Bus char overrun counter	R	0 - 65535	-	OBSERVER	-
3538	3537	Modbus CH2 - Bus message counter	R	0 - 65535	-	OBSERVER	-
3539	3538	Modbus CH2 - Slave message counter	R	0 - 65535	-	OBSERVER	-
3540	3539	Modbus CH2 - Bus communication error counter	R	0 - 65535	-	OBSERVER	-
3541	3540	Modbus CH2 - Bus exception error counter	R	0 - 65535	-	OBSERVER	-
3542	3541	Modbus CH2 - Slave busy counter	R	0 - 65535	-	OBSERVER	-

ICON3000v2 legacy data block							
Holding Register Number	Holding Register Address	Description	RW	Range Value	Eng. Unit	User Level	Notes
3543	3542	Modbus CH2 - Bus char overrun counter	R	0 - 65535	-	OBSERVER	-
3544 - 3549	3543 - 3548	Reserved	R	-	-	OBSERVER	-
3550	3549	Actuator Reset	RW	0 - 65535	-	SERVICE	Reserved for Service Technicians. See Note 14
3551	3550	Backward Compatibility Mode	RW	0 - 1	-	SERVICE	Enumerated: 1 = Backward Compatibility Mode Enabled 0 = Backward Compatibility Mode Disabled
3552	3551	Reserved	R	-	-	OBSERVER	-
3553	3552	Reserved	R	-	-	OBSERVER	-
3554	3553	Local Display Language	RW	0 - 9	-	USER	Enumerated: 9 = German 8 = Romanian 7 = Norwegian 6 = Russian 5 = Turkish 4 = Portuguese 3 = Italian 2 = Spanish 1 = French 0 = English
3555	3554	Logic Card RS232 Baud Rate	RW	0 - 1	-	USER	Enumerated: 1 = 115200 bps 0 = 9600 bps
3556	3555	Wink Command	RW	0 - 1	-	USER	1 = Execute Command (Automatically reset by device)
3557	3556	Force Local Selector	RW	0 - 2	-	SERVICE	Enumerated: 2 = Force selector to LOCAL 1 = Force selector to OFF 0 = No force selector
3558	3557	Bluetooth Name Source	RW	0 - 1	-	USER	Enumerated: 1 = Valve Tag 0 = Actuator Serial Number
3559	3558	Encoder Limit 0% Value (1/2)	R	-	-	OBSERVER	Unsigned 32, MSB. See Note 11
3560	3559	Encoder Limit 0% Value (2/2)	R	-	-	OBSERVER	Unsigned 32, LSB. See Note 11
3561	3560	Encoder Limit 100% Value (1/2)	R	-	-	OBSERVER	Unsigned 32, MSB. See Note 11
3562	3561	Encoder Limit 100% Value (2/2)	R	-	-	OBSERVER	Unsigned 32, LSB. See Note 11
3563	3562	Bluetooth Enabled	RW	0 - 1	-	USER	Enumerated: 1 = Enabled 0 = Disabled
3564	3563	Interlock Signal Type Open	RW	0 - 2	-	USER	Enumerated: 2 = Off 1 = Present 0 = Absent
3565	3564	Interlock Signal Type Close	RW	0 - 2	-	USER	Enumerated: 2 = Off 1 = Present 0 = Absent
3566	3565	2 Speed Timer - Close Direction Status	RW	0 - 1	-	USER	Enumerated: 1 = On 0 = Off
3567	3566	2 Speed Timer - Close Direction Start Position	RW	0 - 100	%	USER	100 = 100%
3568	3567	2 Speed Timer - Close Direction Stop Position	RW	0 - 100	%	USER	100 = 100%
3569	3568	2 Speed Timer - Close Direction ON Time	RW	2 - 200	Seconds	USER	-
3570	3569	2 Speed Timer - Close Direction OFF Time	RW	1 - 200	Seconds	USER	-

ICON3000v2 legacy data block							
Holding Register Number	Holding Register Address	Description	RW	Range Value	Eng. Unit	User Level	Notes
3571	3570	2 Speed Timer - Open Direction Status	RW	0 - 1	-	USER	Enumerated: 1 = On 0 = Off
3572	3571	2 Speed Timer - Open Direction Start Position	RW	0 - 100	%	USER	100 = 100%
3573	3572	2 Speed Timer - Open Direction Stop Position	RW	0 - 100	%	USER	100 = 100%
3574	3573	2 Speed Timer - Open Direction ON Time	RW	2 - 200	Seconds	USER	-
3575	3574	2 Speed Timer - Open Direction OFF Time	RW	1 - 200	Seconds	USER	-
3576	3575	Torque Bypass	RW	0 - 20	%	USER	20 = 20%
3577	3576	Jammed Valve Timeout	RW	0 - 100	Seconds	USER	-
3578	3577	Torque Mode	RW	0 - 1	-	USER	Enumerated: 1 = Standard 0 = 3 Points
3579	3578	9 V Lithium Battery	RW	0 - 1	-	USER	Enumerated: 1 = Present 0 = Absent
3580	3579	Monitor Relay Options	RW	-	-	USER	Bit Field: b8 - b15 = Not Used b7 = Low Battery b6 = Jammed Valve b5 = Over Torque b4 = Motor Hi Temp b3 = Manual Operation b2 = ESD/EFS Active b1 = Local OFF Selected b0 = Local STOP On 1 = Involved in Monitor Relay Status 0 = Not Involved in Monitor Relay Status
3581	3580	AS1 Relay Function	RW	0 - 29	-	USER	Enumerated: 0 = Open limit 1 = Close limit 2 = Position >= % 3 = Position <= % 4 = Closing 5 = Opening 6 = Running 7 = Blinker 8 = Mid-Travel (Intermediate Position) 9 = Local Selected 10 = Remote Selected 11 = Local STOP On 12 = ESD/PST-efs 13 = Manual Operation 14 = Motor Over Temperature Alarm 15 = Hi-Hi Torque Alarm 16 = Hi-Hi Torque Alarm in opening 17 = Hi-Hi Torque Alarm in closing 18 = Jammed Valve in Open 19 = Jammed Valve in Close 20 = Jammed Valve 21 = Low Battery 22 = Warnings 23 = Mid Travel Alarm 24 = EFS in manual 25 = PST Failed 26 = MAINS (only AS8) 27 = EFS Mid Travel Alarm 28 = INTERLOCK/PST-icon 29 = EFS Coil Off 30 = Heater (Only for AS8)

ICON3000v2 legacy data block							
Holding Register Number	Holding Register Address	Description	RW	Range Value	Eng. Unit	User Level	Notes
3582	3581	AS2 Relay Function	RW	0 - 29	-	USER	See HR 3580 "AS1 Relay Function"
3583	3582	AS3 Relay Function	RW	0 - 29	-	USER	See HR 3580 "AS1 Relay Function"
3584	3583	AS4 Relay Function	RW	0 - 29	-	USER	See HR 3580 "AS1 Relay Function"
3585	3584	AS5 Relay Function	RW	0 - 29	-	USER	See HR 3580 "AS1 Relay Function"
3586	3585	AS6 Relay Function	RW	0 - 29	-	USER	See HR 3580 "AS1 Relay Function"
3587	3586	AS7 Relay Function	RW	0 - 29	-	USER	See HR 3580 "AS1 Relay Function"
3588	3587	AS8 Relay Function	RW	0 - 30	-	USER	See HR 3580 "AS1 Relay Function"
3589	3588	AS1 Relay Contact	RW	0 - 1	-	USER	Enumerated: 0 = Break 1 = Make
3590	3589	AS2 Relay Contact	RW	0 - 1	-	USER	Enumerated: 0 = Break 1 = Make
3591	3590	AS3 Relay Contact	RW	0 - 1	-	USER	Enumerated: 0 = Break 1 = Make
3592	3591	AS4 Relay Contact	RW	0 - 1	-	USER	Enumerated: 0 = Break 1 = Make
3593	3592	AS5 Relay Contact	RW	0 - 1	-	USER	Enumerated: 0 = Break 1 = Make
3594	3593	AS6 Relay Contact	RW	0 - 1	-	USER	Enumerated: 0 = Break 1 = Make
3595	3594	AS7 Relay Contact	RW	0 - 1	-	USER	Enumerated: 0 = Break 1 = Make
3596	3595	AS8 Relay Contact	RW	0 - 1	-	USER	Enumerated: 0 = Break 1 = Make
3597	3596	AS1 Relay Position	RW	0 - 100	%	USER	-
3598	3597	AS2 Relay Position	RW	0 - 100	%	USER	-
3599	3598	AS3 Relay Position	RW	0 - 100	%	USER	-
3600	3599	AS4 Relay Position	RW	0 - 100	%	USER	-
3601	3600	AS5 Relay Position	RW	0 - 100	%	USER	-
3602	3601	AS6 Relay Position	RW	0 - 100	%	USER	-
3603	3602	AS7 Relay Position	RW	0 - 100	%	USER	-
3604	3603	AS8 Relay Position	RW	0 - 100	%	USER	-
3605	3604	Duty min. of EFS Control	RW	10 - 100	%	USER	10 = 10%
3606	3605	EFS Action in case of	RW	-	-	USER	Bit Field: b2 - b15 = Not Used b1 = Selector in OFF b0 = Power Failure
3607	3606	EFS Automatic Reset	RW	0 - 1	-	USER	Enumerated: 1 = On 0 = Off
3608	3607	EFS Reset Delay	RW	1 - 255	Seconds	USER	-
3609	3608	Spring Action	RW	0 - 1	-	USER	Enumerated: 1 = Open 0 = Close
3610	3609	Electrical Command	RW	0 - 1	-	USER	Enumerated: 1 = Enabled 0 = Disabled
3611	3610	EFS Input Mode	RW	0 - 1	-	USER	Enumerated: 1 = EFS 0 = PST-efs See Section 11 for details
3612	3611	EFS Signal Type	RW	0 - 1	-	USER	Enumerated: 1 = Present 0 = Absent
3613	3612	PST Mode	RW	0 - 3	-	USER	Enumerated: 3 = Manual + Auto 2 = Manual 1 = Auto 0 = Off

ICON3000v2 legacy data block							
Holding Register Number	Holding Register Address	Description	RW	Range Value	Eng. Unit	User Level	Notes
3614	3613	PST Period	RW	1 - 1000	Days	USER	-
3615	3614	PST Hour	RW	0 - 23	Hours	USER	-
3616	3615	PST Travel	RW	May-40	%	USER	5 = 5%
3617	3616	Max T-PST	RW	1 - 1000	%	USER	1000 = 1000%
3618	3617	PST Pause	RW	2 - 255	Seconds	USER	-
3619	3618	Max T-RET	RW	1 - 1000	%	USER	1000 = 1000%
3620	3619	Max OV-TR	RW	1 - 100	%	USER	10 = 10%
3621	3620	Next PST Date (1/2)	R	-	-	OBSERVER	-
3622	3621	Next PST Date (2/2)	R	-	-	OBSERVER	-
3623	3622	DIN1 Function	RW	0 - 30	-	USER	See HR 3580 "AS1 Relay Function"
3624	3623	DIN2 Function	RW	0 - 30	-	USER	See HR 3580 "AS1 Relay Function"
3625	3624	DIN3 Function	RW	0 - 30	-	USER	See HR 3580 "AS1 Relay Function"
3626	3625	DIN4 Function	RW	0 - 30	-	USER	See HR 3580 "AS1 Relay Function"
3627	3626	DIN5 Function	RW	0 - 30	-	USER	See HR 3580 "AS1 Relay Function"
3628	3627	DIN6 Function	RW	0 - 30	-	USER	See HR 3580 "AS1 Relay Function"
3629	3628	DIN1 Position	RW	0 - 100	%	USER	-
3630	3629	DIN2 Position	RW	0 - 100	%	USER	-
3631	3630	DIN3 Position	RW	0 - 100	%	USER	-
3632	3631	DIN4 Position	RW	0 - 100	%	USER	-
3633	3632	DIN5 Position	RW	0 - 100	%	USER	-
3634	3633	DIN6 Position	RW	0 - 100	%	USER	-
3635 - 3644	3634 - 3643	Reserved	R	-	-	OBSERVER	-
3645	3644	Modbus CH1 Termination	RW	0 - 1	-	USER	Enumerated: 1 = On 0 = Off
3646	3645	Modbus CH2 Termination	RW	0 - 1	-	USER	Enumerated: 1 = On 0 = Off
3647	3646	Modbus Channel Communication	RW	0 - 2	-	USER	Enumerated: 0 = CH1 Enabled, CH2 Disabled 1 = CH1 Disabled, CH2 Enabled 2 = CH1 Enabled, CH1 Enabled
3648	3647	Modbus Repeater Function	RW	-	-	USER	Bit Field: b3 - b15 = Not Used b2 = Repeater B b1 = Repeater A b0 = Node Bypass
3649	3648	Modbus CH1 Address	RW	1 - 247	-	USER	-
3650	3649	Modbus CH1 Baud Rate	RW	2 - 9	-	USER	Enumerated: 2 = Auto Baud 3 = 600 bps 4 = 1200 bps 5 = 2400 bps 6 = 4800 bps 7 = 9600 bps 8 = 19200 bps 9 = 38400 bps
3651	3650	Modbus CH1 Parity	RW	0 - 2	-	USER	Enumerated: 2 = Odd 1 = Even 0 = None
3652	3651	Modbus CH2 Address	RW	1 - 247	-	USER	-
3653	3652	Modbus CH2 Baud Rate	RW	2 - 9	-	USER	See HR 3649 "Modbus CH1 Baud Rate"
3654	3653	Modbus CH2 Parity	RW	0 - 2	-	USER	Enumerated: 2 = Odd 1 = Even 0 = None
3655	3654	Modbus Interface FW Revision	R	0 - 9999	-	OBSERVER	-
3656	3655	Modbus Interface HW Revision	R	0 - 9999	-	OBSERVER	-
3657	3656	ESD Action	RW	0 - 4	-	USER	Enumerated: 4 = Go to % 3 = Stay Put 2 = Open 1 = Close 0 = Off

ICON3000v2 legacy data block							
Holding Register Number	Holding Register Address	Description	RW	Range Value	Eng. Unit	User Level	Notes
3658	3657	ESD Signal Type	RW	0 - 1	-	USER	Enumerated: 1 = Absent 0 = Present
3659	3658	ESD Position	RW	0 - 100	%	USER	100 = 100%
3660	3659	ESD Priority	RW	-	-	USER	Bit Field: b7 = Not Used b6 = 2 Speed Timer b5 = Motion Inhibit b4 = Selector in OFF b3 = Selector in LOCAL b2 = Local STOP Pressed b1 = Hi Torque Alarm b0 = Thermostat 1 = ESD command has priority on selected bit 0 = selected bit has priority on ESD command
3661	3660	Positioner Polarity	RW	0 - 1	-	USER	Enumerated: 1 = Reverse (4 mA = Open) 0 = Standard (4 mA = Close)
3662	3661	Positioner Close Position	RW	0 - 75	%	USER	-
3663	3662	Positioner Open Position	RW	25 - 100	%	USER	-
3664	3663	Output 4 - 20 mA Signal	RW	0 - 1	-	USER	Enumerated: 1 = Torque 0 = Position
3665	3664	Output 4 - 20 mA Polarity	RW	0 - 1	-	USER	Enumerated: 1 = 4 mA Open 0 = 4 mA Close
3666	3665	Close Direction	RW	0 - 1	-	USER	Enumerated: 1 = CCW 0 = CW
3667	3666	Close Limit by	RW	0 - 1	-	USER	Enumerated: 1 = Torque 0 = Position
3668	3667	Open Limit by	RW	0 - 1	-	USER	Enumerated: 1 = Torque 0 = Position
3669	3668	Adjust Open Limit	RW	-50 - 50	%	USER	10 = 1,0%
3670	3669	Adjust Close Limit	RW	-50 - 50	%	USER	10 = 1,0%
3671	3670	Standard Opening Torque	RW	40 - 100	%	USER	-
3672	3671	Standard Closing Torque	RW	40 - 100	%	USER	-
3673	3672	Torque Setup 3p Opening - Break Out	RW	40 - 100	%	USER	-
3674	3673	Torque Setup 3p Opening - Peak Run	RW	40 - 100	%	USER	-
3675	3674	Torque Setup 3p Opening - Ending	RW	40 - 100	%	USER	-
3676	3675	Torque Setup 3p Opening - Break Out Zone	RW	0 - 100	%	USER	-
3677	3676	Torque Setup 3p Opening - Ending Zone	RW	0 - 100	%	USER	-
3678	3677	Torque Setup 3p Closing - Break Out	RW	40 - 100	%	USER	-
3679	3678	Torque Setup 3p Closing - Peak Run	RW	40 - 100	%	USER	-
3680	3679	Torque Setup 3p Closing - Ending	RW	40 - 100	%	USER	-
3681	3680	Torque Setup 3p Closing - Break Out Zone	RW	0 - 100	%	USER	-
3682	3681	Torque Setup 3p Closing - Ending Zone	RW	0 - 100	%	USER	-
3683	3682	Remote Controls	RW	0 - 6	-	USER	Enumerated: 6 = 2 wires open if signal ON 5 = 2 wires open if signal OFF 4 = Reserved 3 = 3 wires latched 2 = 3 wires push to run 1 = 4 wires latched 0 = Off
3684	3683	Remote Stop	RW	0 - 1	-	USER	Enumerated: 1 = Make 0 = Break

ICON3000v2 legacy data block							
Holding Register Number	Holding Register Address	Description	RW	Range Value	Eng. Unit	User Level	Notes
3685	3684	Local Controls - Control Mode	RW	0 - 3	-	USER	Enumerated: 3 = Push to run through AS6-AS7 2 = Latched instant reverse 1 = Push to run 0 = Latched
3686	3685	Local Controls - Led's Color	RW	-	-	USER	Bit Field: b3 - b15 = Not Used b2 = Alarm Led (0 = Red, 1 = Yellow) b1 = Close Led (0 = Red, 1 = Green) b0 = Open Led (0 = Red, 1 = Green)
3687	3686	Actuator Wiring Diagram (1/14)	RW	-	-	SERVICE	ASCII, MSB
3688	3687	Actuator Wiring Diagram (2/14)	RW	-	-	SERVICE	ASCII
3689	3688	Actuator Wiring Diagram (3/14)	RW	-	-	SERVICE	ASCII
3690	3689	Actuator Wiring Diagram (4/14)	RW	-	-	SERVICE	ASCII
3691	3690	Actuator Wiring Diagram (5/14)	RW	-	-	SERVICE	ASCII
3692	3691	Actuator Wiring Diagram (6/14)	RW	-	-	SERVICE	ASCII
3693	3692	Actuator Wiring Diagram (7/14)	RW	-	-	SERVICE	ASCII
3694	3693	Actuator Wiring Diagram (8/14)	RW	-	-	SERVICE	ASCII
3695	3694	Actuator Wiring Diagram (9/14)	RW	-	-	SERVICE	ASCII
3696	3695	Actuator Wiring Diagram (10/14)	RW	-	-	SERVICE	ASCII
3697	3696	Actuator Wiring Diagram (11/14)	RW	-	-	SERVICE	ASCII
3698	3697	Actuator Wiring Diagram (12/14)	RW	-	-	SERVICE	ASCII
3699	3698	Actuator Wiring Diagram (13/14)	RW	-	-	SERVICE	ASCII
3700	3699	Actuator Wiring Diagram (14/14)	RW	-	-	SERVICE	ASCII, LSB
3701	3700	Actuator Enclosure (1/14)	RW	-	-	SERVICE	ASCII, MSB
3702	3701	Actuator Enclosure (2/14)	RW	-	-	SERVICE	ASCII
3703	3702	Actuator Enclosure (3/14)	RW	-	-	SERVICE	ASCII
3704	3703	Actuator Enclosure (4/14)	RW	-	-	SERVICE	ASCII
3705	3704	Actuator Enclosure (5/14)	RW	-	-	SERVICE	ASCII
3706	3705	Actuator Enclosure (6/14)	RW	-	-	SERVICE	ASCII
3707	3706	Actuator Enclosure (7/14)	RW	-	-	SERVICE	ASCII
3708	3707	Actuator Enclosure (8/14)	RW	-	-	SERVICE	ASCII
3709	3708	Actuator Enclosure (9/14)	RW	-	-	SERVICE	ASCII
3710	3709	Actuator Enclosure (10/14)	RW	-	-	SERVICE	ASCII
3711	3710	Actuator Enclosure (11/14)	RW	-	-	SERVICE	ASCII
3712	3711	Actuator Enclosure (12/14)	RW	-	-	SERVICE	ASCII
3713	3712	Actuator Enclosure (13/14)	RW	-	-	SERVICE	ASCII
3714	3713	Actuator Enclosure (14/14)	RW	-	-	SERVICE	ASCII, LSB
3715	3714	Actuator Certificate (1/14)	RW	-	-	SERVICE	ASCII, MSB
3716	3715	Actuator Certificate (2/14)	RW	-	-	SERVICE	ASCII
3717	3716	Actuator Certificate (3/14)	RW	-	-	SERVICE	ASCII
3718	3717	Actuator Certificate (4/14)	RW	-	-	SERVICE	ASCII
3719	3718	Actuator Certificate (5/14)	RW	-	-	SERVICE	ASCII
3720	3719	Actuator Certificate (6/14)	RW	-	-	SERVICE	ASCII
3721	3720	Actuator Certificate (7/14)	RW	-	-	SERVICE	ASCII
3722	3721	Actuator Certificate (8/14)	RW	-	-	SERVICE	ASCII
3723	3722	Actuator Certificate (9/14)	RW	-	-	SERVICE	ASCII
3724	3723	Actuator Certificate (10/14)	RW	-	-	SERVICE	ASCII
3725	3724	Actuator Certificate (11/14)	RW	-	-	SERVICE	ASCII
3726	3725	Actuator Certificate (12/14)	RW	-	-	SERVICE	ASCII

ICON3000v2 legacy data block							
Holding Register Number	Holding Register Address	Description	RW	Range Value	Eng. Unit	User Level	Notes
3727	3726	Actuator Certificate (13/14)	RW	-	-	SERVICE	ASCII
3728	3727	Actuator Certificate (14/14)	RW	-	-	SERVICE	ASCII, LSB
3729	3728	Actuator Lubricant (1/14)	RW	-	-	SERVICE	ASCII, MSB
3730	3729	Actuator Lubricant (2/14)	RW	-	-	SERVICE	ASCII
3731	3730	Actuator Lubricant (3/14)	RW	-	-	SERVICE	ASCII
3732	3731	Actuator Lubricant (4/14)	RW	-	-	SERVICE	ASCII
3733	3732	Actuator Lubricant (5/14)	RW	-	-	SERVICE	ASCII
3734	3733	Actuator Lubricant (6/14)	RW	-	-	SERVICE	ASCII
3735	3734	Actuator Lubricant (7/14)	RW	-	-	SERVICE	ASCII
3736	3735	Actuator Lubricant (8/14)	RW	-	-	SERVICE	ASCII
3737	3736	Actuator Lubricant (9/14)	RW	-	-	SERVICE	ASCII
3738	3737	Actuator Lubricant (10/14)	RW	-	-	SERVICE	ASCII
3739	3738	Actuator Lubricant (11/14)	RW	-	-	SERVICE	ASCII
3740	3739	Actuator Lubricant (12/14)	RW	-	-	SERVICE	ASCII
3741	3740	Actuator Lubricant (13/14)	RW	-	-	SERVICE	ASCII
3742	3741	Actuator Lubricant (14/14)	RW	-	-	SERVICE	ASCII, LSB
3743	3742	Actuator Serial Number (1/14)	RW	-	-	SERVICE	ASCII, MSB
3744	3743	Actuator Serial Number (2/14)	RW	-	-	SERVICE	ASCII
3745	3744	Actuator Serial Number (3/14)	RW	-	-	SERVICE	ASCII
3746	3745	Actuator Serial Number (4/14)	RW	-	-	SERVICE	ASCII
3747	3746	Actuator Serial Number (5/14)	RW	-	-	SERVICE	ASCII
3748	3747	Actuator Serial Number (6/14)	RW	-	-	SERVICE	ASCII
3749	3748	Actuator Serial Number (7/14)	RW	-	-	SERVICE	ASCII
3750	3749	Actuator Serial Number (8/14)	RW	-	-	SERVICE	ASCII
3751	3750	Actuator Serial Number (9/14)	RW	-	-	SERVICE	ASCII
3752	3751	Actuator Serial Number (10/14)	RW	-	-	SERVICE	ASCII
3753	3752	Actuator Serial Number (11/14)	RW	-	-	SERVICE	ASCII
3754	3753	Actuator Serial Number (12/14)	RW	-	-	SERVICE	ASCII
3755	3754	Actuator Serial Number (13/14)	RW	-	-	SERVICE	ASCII
3756	3755	Actuator Serial Number (14/14)	RW	-	-	SERVICE	ASCII, LSB
3757	3756	Actuator Type (1/14)	RW	-	-	SERVICE	ASCII, MSB
3758	3757	Actuator Type (2/14)	RW	-	-	SERVICE	ASCII
3759	3758	Actuator Type (3/14)	RW	-	-	SERVICE	ASCII
3760	3759	Actuator Type (4/14)	RW	-	-	SERVICE	ASCII
3761	3760	Actuator Type (5/14)	RW	-	-	SERVICE	ASCII
3762	3761	Actuator Type (6/14)	RW	-	-	SERVICE	ASCII
3763	3762	Actuator Type (7/14)	RW	-	-	SERVICE	ASCII
3764	3763	Actuator Type (8/14)	RW	-	-	SERVICE	ASCII
3765	3764	Actuator Type (9/14)	RW	-	-	SERVICE	ASCII
3766	3765	Actuator Type (10/14)	RW	-	-	SERVICE	ASCII
3767	3766	Actuator Type (11/14)	RW	-	-	SERVICE	ASCII
3768	3767	Actuator Type (12/14)	RW	-	-	SERVICE	ASCII
3769	3768	Actuator Type (13/14)	RW	-	-	SERVICE	ASCII
3770	3769	Actuator Type (14/14)	RW	-	-	SERVICE	ASCII, LSB
3771	3770	Test Date (1/2)	RW	-	-	SERVICE	BCD Format. See Note 2
3772	3771	Test Date (2/2)	RW	-	-	SERVICE	BCD Format. See Note 2
3773	3772	Logic Card HW Revision	R	0 - 99	-	OBSERVER	-
3774	3773	Logic Card FW Revision - PIC (1/2)	R	-	-	OBSERVER	ASCII, MSB
3775	3774	Logic Card FW Revision - PIC (2/2)	R	-	-	OBSERVER	ASCII, LSB
3776	3775	Absolute Encoder - HW Revision (1/2)	R	-	-	OBSERVER	MSB
3777	3776	Absolute Encoder - HW Revision (2/2)	R	-	-	OBSERVER	LSB
3778	3777	Absolute Encoder - FW Revision (1/2)	R	-	-	OBSERVER	MSB
3779	3778	Absolute Encoder - FW Revision (2/2)	R	-	-	OBSERVER	LSB
3780	3779	Actuator Speed Engineering Unit	RW	0 - 3	-	SERVICE	Enumerated: 3 = ins/s 2 = mm/s 1 = rpm 0 = s/90°
3781	3780	Actuator Speed Value (1/4)	RW	-	-	SERVICE	ASCII, MSB
3782	3781	Actuator Speed Value (2/4)	RW	-	-	SERVICE	ASCII
3783	3782	Actuator Speed Value (3/4)	RW	-	-	SERVICE	ASCII

ICON3000v2 legacy data block							
Holding Register Number	Holding Register Address	Description	RW	Range Value	Eng. Unit	User Level	Notes
3784	3783	Actuator Speed Value (4/4)	RW	-	-	SERVICE	ASCII, LSB, 1 character
3785	3784	Torque/Thrust Engineering Unit	RW	0 - 3	-	SERVICE	Enumerated: 3 = ins/s 2 = mm/s 1 = rpm 0 = s/90°
3786	3785	Torque/Thrust Value (1/4)	RW	-	-	SERVICE	ASCII, MSB
3787	3786	Torque/Thrust Value (2/4)	RW	-	-	SERVICE	ASCII
3788	3787	Torque/Thrust Value (3/4)	RW	-	-	SERVICE	ASCII
3789	3788	Torque/Thrust Value (4/4)	RW	-	-	SERVICE	ASCII, LSB, 1 character
3790	3789	Torque Sensor F01 - Potentiometer Opening 50%	RW	0 - 1023	-	SERVICE	-
3791	3790	Torque Sensor F01 - Potentiometer Opening 100%	RW	0 - 1023	-	SERVICE	-
3792	3791	Torque Sensor F01 - Potentiometer Closing 50%	RW	0 - 1023	-	SERVICE	-
3793	3792	Torque Sensor F01 - Potentiometer Closing 100%	RW	0 - 1023	-	SERVICE	-
3794	3793	Torque Sensor F01 - Factory Torque Limit Opening	RW	0 - 1023	-	SERVICE	-
3795	3794	Torque Sensor F01 - Factory Torque Limit Closing	RW	0 - 1023	-	SERVICE	-
3796	3795	Power Supply Type	RW	0 - 2	-	SERVICE	Enumerated: 2 = DC 1 = AC 1 Phase 0 = AC 3 Phase
3797	3796	Power Supply Voltage	RW	10 - 1000	V	SERVICE	10 = 10 V
3798	3797	Power Supply Frequency	RW	0 - 1	-	SERVICE	Enumerated: 1 = 60 Hz 0 = 50 Hz
3799	3798	Motor Type	RW	0 - 2	-	SERVICE	Enumerated: 2 = DC 1 = AC 1 Phase 0 = AC 3 Phase
3800	3799	Motor Rating	RW	0 - 9999	KW	SERVICE	10 = 0,1 KW
3801	3800	Motor Poles	RW	0 - 15	-	SERVICE	Enumerated: 15 = 32 poles 14 = 30 poles 13 = 28 poles 12 = 26 poles 11 = 24 poles 10 = 22 poles 9 = 20 poles 8 = 18 poles 7 = 16 poles 6 = 14 poles 5 = 12 poles 4 = 10 poles 3 = 8 poles 2 = 6 poles 1 = 4 poles 0 = 2 poles
3802	3801	Motor Current - In	RW	0 - 999	A	SERVICE	10 = 1,0 A
3803	3802	Motor Current - Is	RW	0 - 9999	A	SERVICE	10 = 1,0 A
3804	3803	Motor Current - Icc	RW	0 - 9999	A	SERVICE	10 = 1,0 A
3805	3804	Motor Reduction Gear	RW	1 - 1000	-	SERVICE	-
3806	3805	Motor Service	RW	0 - 6	-	SERVICE	Enumerated: 6 = S9 5 = S4/25%/3600 start/h 4 = S4/25%/1200 start/h 3 = S4/25%/600 start/h 2 = S4/25%/200 start/h 1 = S4/25%/60 start/h 0 = S2/15 min

ICON3000v2 legacy data block							
Holding Register Number	Holding Register Address	Description	RW	Range Value	Eng. Unit	User Level	Notes
3807	3806	Motor Code (1/14)	RW	-	-	SERVICE	ASCII, MSB
3808	3807	Motor Code (2/14)	RW	-	-	SERVICE	ASCII
3809	3808	Motor Code (3/14)	RW	-	-	SERVICE	ASCII
3810	3809	Motor Code (4/14)	RW	-	-	SERVICE	ASCII
3811	3810	Motor Code (5/14)	RW	-	-	SERVICE	ASCII
3812	3811	Motor Code (6/14)	RW	-	-	SERVICE	ASCII
3813	3812	Motor Code (7/14)	RW	-	-	SERVICE	ASCII
3814	3813	Motor Code (8/14)	RW	-	-	SERVICE	ASCII
3815	3814	Motor Code (9/14)	RW	-	-	SERVICE	ASCII
3816	3815	Motor Code (10/14)	RW	-	-	SERVICE	ASCII
3817	3816	Motor Code (11/14)	RW	-	-	SERVICE	ASCII
3818	3817	Motor Code (12/14)	RW	-	-	SERVICE	ASCII
3819	3818	Motor Code (13/14)	RW	-	-	SERVICE	ASCII
3820	3819	Motor Code (14/14)	RW	-	-	SERVICE	ASCII, LSB
3821	3820	Torque Sensor I24 - Speed Opening 0% (+5%)	RW	0 - 5000	rpm	SERVICE	-
3822	3821	Torque Sensor I24 - Speed Opening 40% (+5%)	RW	0 - 5000	rpm	SERVICE	-
3823	3822	Torque Sensor I24 - Speed Opening 70% (+5%)	RW	0 - 5000	rpm	SERVICE	-
3824	3823	Torque Sensor I24 - Speed Opening 100% (+5%)	RW	0 - 5000	rpm	SERVICE	-
3825	3824	Torque Sensor I24 - Speed Opening 40% (-5%)	RW	0 - 5000	rpm	SERVICE	-
3826	3825	Torque Sensor I24 - Speed Opening 70% (-5%)	RW	0 - 5000	rpm	SERVICE	-
3827	3826	Torque Sensor I24 - Speed Opening 100% (-5%)	RW	0 - 5000	rpm	SERVICE	-
3828	3827	Torque Sensor I24 - Speed Closing 0% (+5%)	RW	0 - 5000	rpm	SERVICE	-
3829	3828	Torque Sensor I24 - Speed Closing 40% (+5%)	RW	0 - 5000	rpm	SERVICE	-
3830	3829	Torque Sensor I24 - Speed Closing 70% (+5%)	RW	0 - 5000	rpm	SERVICE	-
3831	3830	Torque Sensor I24 - Speed Closing 100% (+5%)	RW	0 - 5000	rpm	SERVICE	-
3832	3831	Torque Sensor I24 - Speed Closing 40% (-5%)	RW	0 - 5000	rpm	SERVICE	-
3833	3832	Torque Sensor I24 - Speed Closing 70% (-5%)	RW	0 - 5000	rpm	SERVICE	-
3834	3833	Torque Sensor I24 - Speed Closing 100% (-5%)	RW	0 - 5000	rpm	SERVICE	-
3835	3834	Torque Sensor I24 - Voltage	RW	10 - 1000	V	SERVICE	-
3836	3835	Torque Sensor I24 - Frequency	RW	0 - 1	-	SERVICE	Enumerated: 0 = 50 Hz 1 = 60 Hz
3837	3836	Torque Sensor I24 - K Temp	RW	0 - 20	%	SERVICE	-
3838	3837	Torque Sensor I24 - Factory Torque Limit Opening	RW	0 - 255	-	SERVICE	-
3839	3838	Torque Sensor I24 - Factory Torque Limit Closing	RW	0 - 255	-	SERVICE	-
3840	3839	Valve Serial Number (1/14)	RW	-	-	USER	ASCII, MSB
3841	3840	Valve Serial Number (2/14)	RW	-	-	USER	ASCII
3842	3841	Valve Serial Number (3/14)	RW	-	-	USER	ASCII
3843	3842	Valve Serial Number (4/14)	RW	-	-	USER	ASCII
3844	3843	Valve Serial Number (5/14)	RW	-	-	USER	ASCII
3845	3844	Valve Serial Number (6/14)	RW	-	-	USER	ASCII
3846	3845	Valve Serial Number (7/14)	RW	-	-	USER	ASCII
3847	3846	Valve Serial Number (8/14)	RW	-	-	USER	ASCII
3848	3847	Valve Serial Number (9/14)	RW	-	-	USER	ASCII
3849	3848	Valve Serial Number (10/14)	RW	-	-	USER	ASCII

ICON3000v2 legacy data block							
Holding Register Number	Holding Register Address	Description	RW	Range Value	Eng. Unit	User Level	Notes
3850	3849	Valve Serial Number (11/14)	RW	-	-	USER	ASCII
3851	3850	Valve Serial Number (12/14)	RW	-	-	USER	ASCII
3852	3851	Valve Serial Number (13/14)	RW	-	-	USER	ASCII
3853	3852	Valve Serial Number (14/14)	RW	-	-	USER	ASCII, LSB
3854	3853	Valve Manufacturer (1/14)	RW	-	-	USER	ASCII, MSB
3855	3854	Valve Manufacturer (2/14)	RW	-	-	USER	ASCII
3856	3855	Valve Manufacturer (3/14)	RW	-	-	USER	ASCII
3857	3856	Valve Manufacturer (4/14)	RW	-	-	USER	ASCII
3858	3857	Valve Manufacturer (5/14)	RW	-	-	USER	ASCII
3859	3858	Valve Manufacturer (6/14)	RW	-	-	USER	ASCII
3860	3859	Valve Manufacturer (7/14)	RW	-	-	USER	ASCII
3861	3860	Valve Manufacturer (8/14)	RW	-	-	USER	ASCII
3862	3861	Valve Manufacturer (9/14)	RW	-	-	USER	ASCII
3863	3862	Valve Manufacturer (10/14)	RW	-	-	USER	ASCII
3864	3863	Valve Manufacturer (11/14)	RW	-	-	USER	ASCII
3865	3864	Valve Manufacturer (12/14)	RW	-	-	USER	ASCII
3866	3865	Valve Manufacturer (13/14)	RW	-	-	USER	ASCII
3867	3866	Valve Manufacturer (14/14)	RW	-	-	USER	ASCII, LSB
3868	3867	Valve Break to Open Torque (1/14)	RW	-	-	USER	ASCII, MSB
3869	3868	Valve Break to Open Torque (2/14)	RW	-	-	USER	ASCII
3870	3869	Valve Break to Open Torque (3/14)	RW	-	-	USER	ASCII
3871	3870	Valve Break to Open Torque (4/14)	RW	-	-	USER	ASCII
3872	3871	Valve Break to Open Torque (5/14)	RW	-	-	USER	ASCII
3873	3872	Valve Break to Open Torque (6/14)	RW	-	-	USER	ASCII
3874	3873	Valve Break to Open Torque (7/14)	RW	-	-	USER	ASCII
3875	3874	Valve Break to Open Torque (8/14)	RW	-	-	USER	ASCII
3876	3875	Valve Break to Open Torque (9/14)	RW	-	-	USER	ASCII
3877	3876	Valve Break to Open Torque (10/14)	RW	-	-	USER	ASCII
3878	3877	Valve Break to Open Torque (11/14)	RW	-	-	USER	ASCII
3879	3878	Valve Break to Open Torque (12/14)	RW	-	-	USER	ASCII
3880	3879	Valve Break to Open Torque (13/14)	RW	-	-	USER	ASCII
3881	3880	Valve Break to Open Torque (14/14)	RW	-	-	USER	ASCII, LSB
3882	3881	Valve Max Steam Thrust (1/14)	RW	-	-	USER	ASCII, MSB
3883	3882	Valve Max Steam Thrust (2/14)	RW	-	-	USER	ASCII
3884	3883	Valve Max Steam Thrust (3/14)	RW	-	-	USER	ASCII
3885	3884	Valve Max Steam Thrust (4/14)	RW	-	-	USER	ASCII
3886	3885	Valve Max Steam Thrust (5/14)	RW	-	-	USER	ASCII
3887	3886	Valve Max Steam Thrust (6/14)	RW	-	-	USER	ASCII
3888	3887	Valve Max Steam Thrust (7/14)	RW	-	-	USER	ASCII
3889	3888	Valve Max Steam Thrust (8/14)	RW	-	-	USER	ASCII
3890	3889	Valve Max Steam Thrust (9/14)	RW	-	-	USER	ASCII
3891	3890	Valve Max Steam Thrust (10/14)	RW	-	-	USER	ASCII
3892	3891	Valve Max Steam Thrust (11/14)	RW	-	-	USER	ASCII
3893	3892	Valve Max Steam Thrust (12/14)	RW	-	-	USER	ASCII
3894	3893	Valve Max Steam Thrust (13/14)	RW	-	-	USER	ASCII
3895	3894	Valve Max Steam Thrust (14/14)	RW	-	-	USER	ASCII, LSB
3896	3895	Valve Coupling Type (1/14)	RW	-	-	USER	ASCII, MSB
3897	3896	Valve Coupling Type (2/14)	RW	-	-	USER	ASCII
3898	3897	Valve Coupling Type (3/14)	RW	-	-	USER	ASCII
3899	3898	Valve Coupling Type (4/14)	RW	-	-	USER	ASCII
3900	3899	Valve Coupling Type (5/14)	RW	-	-	USER	ASCII
3901	3900	Valve Coupling Type (6/14)	RW	-	-	USER	ASCII
3902	3901	Valve Coupling Type (7/14)	RW	-	-	USER	ASCII
3903	3902	Valve Coupling Type (8/14)	RW	-	-	USER	ASCII
3904	3903	Valve Coupling Type (9/14)	RW	-	-	USER	ASCII
3905	3904	Valve Coupling Type (10/14)	RW	-	-	USER	ASCII
3906	3905	Valve Coupling Type (11/14)	RW	-	-	USER	ASCII
3907	3906	Valve Coupling Type (12/14)	RW	-	-	USER	ASCII
3908	3907	Valve Coupling Type (13/14)	RW	-	-	USER	ASCII
3909	3908	Valve Coupling Type (14/14)	RW	-	-	USER	ASCII, LSB

ICON3000v2 legacy data block							
Holding Register Number	Holding Register Address	Description	RW	Range Value	Eng. Unit	User Level	Notes
3910	3909	Hardware Configuration	RW	0 - 12	-	SERVICE	Enumerated: 12 = Mod - 1CHR 11 = ProV2_R 10 = ProV2 9 = Modbus Dewa 8 = ProV1_R 7 = ProV1 6 = HART 5 = FF 4 = Modbus M 3 = Profibus 2 = Modbus 1 = LonWorks 0 = Base Card (No bus card)
3911	3910	Software Type	RW	0 - 4	-	SERVICE	Enumerated: 4 = EPN 3 = EFS 2 = 6K 1 = F01 0 = ICON/XTE
3912	3911	Logic Card Manufacturer	R	0 - 1	-	SERVICE	Enumerated: 1 = Emerson 0 = Biffi
3913	3912	4 - 20 mA Card	RW	0 - 1	-	SERVICE	Enumerated: 1 = Present 0 = Absent
3914	3913	Sleep Mode	RW	0 - 1	-	SERVICE	-
3915	3914	Monitor Relay in Sleep Mode	RW	0 - 1	-	SERVICE	-
3916	3915	Heater Base Reference	RW	-50 - 50	°C	SERVICE	-
3917	3916	Heater Display Reference	RW	-50 - 50	°C	SERVICE	-
3918	3917	Heater Terminal Board Reference	RW	-50 - 50	°C	SERVICE	-
3919	3918	CMD Filter (Terminal Board Filter)	RW	0 - 100	-	SERVICE	-
3920	3919	ESD/Interlock Dig. Input Filter	RW	0 - 30	-	SERVICE	-
3921	3920	Interlock Mode	RW	0 - 1	-	SERVICE	Enumerated: 0 = Standard 1 = Advanced See Section 12 for details
3922	3921	Reversal Delay	RW	5 - 50	Seconds	SERVICE	-
3923	3922	Direction Test Timeout	RW	0 - 25	-	SERVICE	-
3924	3923	Torque Stop Zone	RW	0 - 20	-	SERVICE	-
3925	3924	Speed By-pass	RW	0 - 255	Seconds	SERVICE	12 = 1,2 s
3926	3925	Current Sensor - 2 A	RW	0 - 1023	-	SERVICE	-
3927	3926	Current Sensor - 3.5 A	RW	0 - 1023	-	SERVICE	-
3928	3927	Current Sensor - 7 A	RW	0 - 1023	-	SERVICE	-
3929	3928	Current Sensor - 15 A	RW	0 - 1023	-	SERVICE	-
3930	3929	Current Sensor - 30 A	RW	0 - 1023	-	SERVICE	-
3931	3930	4 - 20 mA Input Configuration - 4 mA	RW	0 - 1900	-	SERVICE	-
3932	3931	4 - 20 mA Input Configuration - 20 mA	RW	2100 - 4095	-	SERVICE	-
3933	3932	4 - 20 mA Output Configuration - 4 mA	RW	0 - 1900	-	SERVICE	-
3934	3933	4 - 20 mA Output Configuration - 20 mA	RW	2100 - 4095	-	SERVICE	-
3935	3934	Additional Variables	RW	0 - 1	-	SERVICE	Enumerated: 1 = Extended 0 = Standard
3936	3935	Back Light	RW	0 - 1	-	SERVICE	Enumerated: 1 = Always On 0 = Auto
3937	3936	Position Request From	RW	0 - 1	-	SERVICE	Enumerated: 1 = Bus 0 = 4 - 20 mA
3938	3937	1P Man	RW	0 - 1	-	SERVICE	Enumerated: 1 = Enabled 0 = Disabled
3939	3938	Positioner Function	RW	0 - 1	-	SERVICE	Enumerated: 1 = Enabled 0 = Disabled

ICON3000v2 legacy data block								
Holding Register Number	Holding Register Address	Description	RW	Range Value	Eng. Unit	User Level	Notes	
3940	3939	Bus AN-OUT	RW	0 - 1	-	SERVICE	Enumerated: 1 = Torque + Temperature 0 = Torque	
3941	3940	Fail-Safe	RW	0 - 1	-	SERVICE	Enumerated: 1 = Enabled 0 = Disabled	
3942	3941	Serial Command	RW	0 - 1	-	SERVICE	Enumerated: 1 = Enabled 0 = Disabled	
3943	3942	Upload New Firmware	RW	0 - 1	-	SERVICE	Enumerated: 1 = Yes 0 = No	
3944	3943	Speed Band	RW	0 - 255	-	SERVICE	-	
3945	3944	Terminal Board	RW	0 - 4	-	SERVICE	Enumerated: 4 = I24 Gold PR 3 = 12 Relays 2 = 8/9 Relays 1 = 5 Relays 0 = I24	
3946	3945	Selector Mode	RW	0 - 1	-	SERVICE	Enumerated: 1 = Local + Remote 0 = Local	
3947	3946	Voltage Span	RW	10 - 1000	V	SERVICE	-	
3948	3947	Voltage Span (bit)	RW	0 - 1023	-	OBSERVER	-	
3949	3948	Local Display Password (1/2)	RW	-	-	USER	ASCII, MSB. See Note 15	
3950	3949	Local Display Password (2/2)	RW	-	-	USER	ASCII, LSB. See Note 15	
3951	3950	Log Start Date (1/2)	RW	-	-	USER	BCD Format. See Note 2	
3952	3951	Log Start Date (2/2)	RW	-	-	USER	BCD Format. See Note 2	
3953	3952	Log Start Time (1/2)	RW	-	-	USER	BCD Format. See Note 3	
3954	3953	Log Start Time (2/2)	RW	-	-	USER	BCD Format. See Note 3	
3955	3954	Logger Mode	RW	0 - 3	-	USER	Enumerated: 3 = T-Recorder 2 = Recorder 1 = Event 0 = Off	
3956	3955	Memory Mode	RW	0 - 1	-	USER	Enumerated: 1 = Stop when full 0 = Continuous	
3957	3956	Sample Interval	RW	1 - 3600	Seconds	USER	-	
3958	3957	Byte Free 0	RW	0 - 255	-	USER	-	
3959	3958	Byte Free 1	RW	0 - 255	-	USER	-	
3960	3959	Byte Free 2	RW	0 - 255	-	USER	-	
3961	3960	Byte Free 3	RW	0 - 255	-	USER	-	
3962	3961	Byte Free 4	RW	0 - 255	-	USER	-	
3963	3962	Byte Free 5	RW	0 - 255	-	USER	-	
3964	3963	Byte Free 6	RW	0 - 255	-	USER	-	
3965	3964	Byte Free 7	RW	0 - 255	-	USER	-	
3966	3965	Bit Free 0	RW	0 - 1	-	USER	-	
3967	3966	Bit Free 1	RW	0 - 1	-	USER	-	
3968	3967	Bit Free 2	RW	0 - 1	-	USER	-	
3969	3968	Bit Free 3	RW	0 - 1	-	USER	-	
3970	3969	Bit Free 4	RW	0 - 1	-	USER	-	
3971	3970	Bit Free 5	RW	0 - 1	-	USER	-	
3972	3971	Bit Free 6	RW	0 - 1	-	USER	-	
3973	3972	Bit Free 7	RW	0 - 1	-	USER	-	
3974	3973	Word Free 0	RW	0 - 65535	-	USER	-	
3975	3974	Word Free 1	RW	0 - 65535	-	USER	-	
3976	3975	Word Free 2	RW	0 - 65535	-	USER	-	
3977	3976	Word Free 3	RW	0 - 65535	-	USER	-	
3978	3977	Word Free 4	RW	0 - 65535	-	USER	-	
3979	3978	Word Free 5	RW	0 - 65535	-	USER	-	
3980	3979	Word Free 6	RW	0 - 65535	-	USER	-	
3981	3980	Word Free 7	RW	0 - 65535	-	USER	-	

ICON3000v2 legacy data block							
Holding Register Number	Holding Register Address	Description	RW	Range Value	Eng. Unit	User Level	Notes
3982	3981	Set Close Reference Torque Curve	RW	0 - 100	-	USER	0 is not a writable value. It's returned only if Ref. Curve is not set
3983	3982	Set Open Reference Torque Curve	RW	0 - 100	-	USER	0 is not a writable value. It's returned only if Ref. Curve is not set
3984	3983	Set PST Reference Curve	RW	0 - 16	-	USER	0 is not a writable value. It's returned only if Ref. Curve is not set
3985	3984	Set EFS Reference Curve	RW	0 - 16	-	USER	0 is not a writable value. It's returned only if Ref. Curve is not set
3986	3985	Set Torque Profile	RW	0 - 1	-	USER	Automatically reset by device
3987	3986	Clear Recent Data Log	RW	0 - 1	-	USER	Automatically reset by device
3988	3987	Bus Monitor	RW	0 - 1	-	SERVICE	Enumerated: 1 = Bus Monitor Enabled 0 = Bus Monitor Disabled See Section 9.5 for details
3989	3988	Maintenance Operation Command	RW	0 - 1	-	SERVICE	Enumerated: 0 = Not Active 1 = Active See Section 9.5 for details

NOTE:

1. “Actuator Commands”, “Actuator Commands 2”:

It’s an enumerated register, the possible values are:

Value	Description
0	Clear Commands
1	Generate Close Command
2	Generate Open Command
3	ESD Command
4	Enable Positioner Mode
5	PST Command
6	Baseline PST Command

Each command is active until a new value of this register is received from the host.

“Open Command” and “Close Command” are also cleared in the following situations:

- Local STOP Pressed
- Local selector in OFF or LOCAL
- ESD/PST Command active
- Remote Hardwired controls active
- Alarm*
- End of travel

When “Enable Positioner Mode” command is sent to the Modbus RTU Interface, the actuator will position according to the content of “Position Request” Holding Register (Addresses 1 or 3007).

The command “Enable Positioner Mode” and the Holding Registers “Position Request” (HR 1, 3007), “Dead Band” (HR 2, 3017), “Motion Inhibit Time” (HR 3, 3018) are used only by modulating actuators.

“PST command” and “Baseline PST Command” are automatically cleared by the device.

The commands can be sent to the actuator also with Function Codes 05 (Write Single Coil) and 15 (Write Multiple Coils); it is recommended to verify the absence of conflict between commands from coils and commands from registers.

*“Low Battery” alarm (HR 3010 “Alarms1”, bit 13) doesn’t clear Open and Close commands.

2. “Next Maintenance Date”, “Last Maintenance Date”, “Current Date”, Start Up Date”, “Test Date”, “Recent Log Date”, “Last Torque profile in OP - Date”, “Last Torque profile in CL - Date”, “Torque reference profile in OP - Date”, “Torque reference profile in CL - Date”, “Log Start Date”, “Alarm Log 1 - Date”, “Alarm Log 2 - Date”, “Alarm Log 3 - Date”, “Alarm Log 4 - Date”, “Alarm Log 5 - Date”, “Warning Log 1 - Date”, “Warning Log 2 - Date”, “Warning Log 3 - Date”, “Warning Log 4 - Date”, “Warning Log 5 - Date”:

These registers contain date data that are represented in BCD format. The first register contains the day (in the first byte) and the month (in the second byte); the second register contains the year.

Example: Next Maintenance Date (H. Registers 13, 14 - Address 12, 13)

Holding Register 12 = 0x1511 → Day: 15, Month: 11 (November)
Holding Register 13 = 0x2020 → Year: 2020

3. “Current Time”, “Log Start Time”, “Alarm Log 1 - Time”, “Alarm Log 2 - Time”, “Alarm Log 3 - Time”, “Alarm Log 4 - Time”, “Alarm Log 5 - Time”, “Warning Log 1 - Time”, “Warning Log 2 - Time”, “Warning Log 3 - Time”, “Warning Log 4 - Time”, “Warning Log 5 - Time”:

These registers contain time data that are represented in BCD format. The first register contains the hours (MSB byte is not used and fixed to 0, the LSB byte contains the hours); the second register contains the minutes (in the MSB byte) and the seconds (in the LSB byte).

Example: Alarm Log 1 - Time (Input Registers Addresses 48, 49)

Input Register 48 = 0x0017 → Hours: 17
Input Register 49 = 0x4239 → Minutes: 42, Seconds: 39

4. “Actuator Commands 1”:

“Open” and “Close” commands are self-maintained.

“Local Stop pressed”, “Selector in OFF”, “Selector in LOCAL” stops temporarily “Open”, “Close”, “Stop”, “ESD”, “Positioner Mode” commands; when the local STOP is depressed, or the selector returns in REMOTE position, the previous command is restored.

If “ESD command” value is ON, an ESD command is generated. When the signal returns to OFF, the ESD command is cleared.

If the “PST command” value is ON, a PST command is generated. “Local Stop pressed” and “Selector in OFF” stops the PST command.

If the “PST command” value is ON and the PST command has been already executed, to perform a new PST command the relevant bit must be cleared and re-set to ON.

“Positioner Mode” command is available only in modulating actuators.

If its value is ON, the positioner function is enabled, and the actuator will position according to the content of position request register (Holding Register addresses 1 or 3007).

The table below shows the possible values:

Value	Description
b0	1 = Close Command
b1	1 = Open Command
b2	1 = Stop Command
b3	1 = ESD Command
b4	1 = Enable Positioner Mode
b5	1 = PST Command

5. “Aux. Analog Input 12 bit”:

This register contains the Auxiliary Analog Input value scaled on 0 - 4095 (12 bit). If the Auxiliary Analog Input is lower or equal to 4 mA, it assumes the value 0. If the Auxiliary Analog Input is higher or equal to 20 mA, it assumes the value 4095.

6. “Clear Alarms and Warnings Log”

It’s always read as 0.

Value	Description
0	No command
1	Clear Alarms and Warnings Log command

If it’s set to 1, it’s automatically cleared by the device.

7. “Reset Alarms and Warnings”

It’s always read as 0.

Value	Description
0	No command
1	Reset Alarms and Warnings command

If it’s set to 1, it’s automatically cleared by the device.

8. “Nominal Torque/Thrust”:

“These registers contain two types of data. The first register (address 3074) contains the torque/thrust engineering unit in the first byte and an ASCII character in the second byte.

Other registers contain ASCII characters, one character for each byte. The table below shows the engineering unit codes:

Value	Description
0	lbf
1	Nm
2	lb
3	KN

9. “Alarm Log 1 - Code”, “Alarm Log 2 - Code”, Alarm Log 3 - Code”, “Alarm Log 4 - Code”, “Alarm Log 5 - Code”:

Registers from address 3090 to 3094 contain data of the most recent alarm (Alarm Log 1); registers from address 3095 to 3099 contain data of the second recent alarm (Alarm Log 2); registers from address 3100 to 3104 contain data of the third recent alarm (Alarm Log 3); registers from address 3105 to 3109 contain data of the fourth recent alarm (Alarm Log 4); registers from address 3110 to 3114 contain data if the fifth recent alarm (Alarm Log 5).

Value	Description
0	None
1	Configuration Error
2	Motor Thermostat
3	Hi Hi Temperature
4	Low Battery
5	Hi-Hi Torque in close direction
6	Hi-Hi Torque in open direction
7	Valve Jammed in close
8	Valve Jammed in open
9	Position Sensor
10	Speed Sensor or Direction

Value	Description
11	Main Voltage
12	Lost Phase
13	K1 Contactor
14	K2 Contactor
15	Mid travel alarm in close
16	Mid travel alarm in open
17	Hardware 1
18	Request Signal
19	Direction Test
20	Hardware 2
21	Hardware 3
22	Hardware 4
23	Hardware 5
24	Hardware 6
25	Hardware 7
26	Hardware 8
27	Hardware 9
28	Hardware 10
29	EFS Mid Travel
30	Hardware 11
31	Hardware 12
32	Hardware 13

“Alarm Log - Code” registers contain the alarm code; the data type is enumerated:

10. “Warning Log 1 - Code”, “Warning Log 2 - Code”, “Warning Log 3 - Code”, “Warning Log 4 - Code”, “Warning Log 5 - Code”:

Registers from address 3115 to 3119 contain data of the most recent warning; registers from address 3120 to 3124 contain data of the second recent warning; registers from address 3125 to 3129 contain data of the third recent warning; registers from address 3130 to 3134 contain data of the fourth recent warning; registers from address 3135 to 3139 contain data if the fifth recent warning.

“Warning Log - Code” registers contain the warning code; the data type is enumerated:

Value	Description
0	None
1	Hi Torque in opening
2	Hi Torque in closing
3	Hi Temperature
4	Main Supply
5	Max. Contactor Cycles
6	Maintenance Request
7	Motor Current
8	Wrong Stroke Limits
9	Bus
10	PST Failed
11	PST Failed - Max T1
12	PST Failed - Max T2
13	PST Failed - Over Travel

11. “Contactor Cycles”, “Recent Contactor Cycles”, “Motor Run Time”, “Recent Motor Run Time”, “Time without electrical power”, “Recent time without electrical power”, “Encoder Absolute Position”, “Encoder Limit 0% Value”, “Encoder Limit 100% Value”:

These data are contained in two registers. The first register contains high order bits, the second contains the low order bits.

12. “Last Close Torque Curve”, “Reference Close Torque Curve”, “Last Open Torque Curve”, “Reference Open Torque Curve”:

These registers contain several types of data; the combination of this data is described, byte per byte, in the table below:

Each register contains 2 bytes of torque curve data.

Byte	Description
1 st - 101 st	Torque Samples* (One sample for each byte)
102 nd	Date of torque curve (BCD format): Day
103 rd	Date of torque curve (BCD format): Month
104 th	Date of torque curve (BCD format): Year minus 2000
105 th	Time of torque curve (BCD format): seconds
106 th	Time of torque curve (BCD format): minutes
107 th	Time of torque curve (BCD format): hours
108 th	Electronic temperature (signed char, range: -127 - +127, eng. unit: °C)
109 th	Terminal board temperature (signed char, range: -127 - +127, eng. unit: °C)
110 th	Mot/speed temperature (signed char, range: -127 - +127, eng. unit: °C)
111 th - 112 th	Voltage. First byte contains most significant bits (eng. unit: V)
113 th - 114 th	Closing/Opening time. First byte contains most significant bits (eng. unit: seconds)
115 th - 128 th	Reserved data

NOTE:

* The index of these bytes indicates the actuator position.

Example: index 1 indicates the output torque on the position 0%; index 2 indicates the output torque on the position 1%, and so on).

13. “User Password”:

Always read as 0x0000.

14. “Actuator Reset”:

This command performs an actuator reset and it’s reserved for Service Technicians.

15. “Local Display Password”:

These registers contain ASCII characters, one character for each byte.

Each ASCII character can assume only numeric values from “0” (0x030) to “9” (0x39).

Always read as 0x0000.

16. “Actuator Type”:

These registers are available from Modbus RTU Interface firmware Revision 2.03.

Section 8: Modbus Function Description

The following paragraph describes the input and output messages of the Modbus RTU Interface. In all cases it's called "input signal" a data flowing from actuator to BUS, vice versa it's called "output signal" a data flowing from BUS to slave.

The following functions are supported by the Modbus RTU Interface:

Table 6.

Function Code	Modbus Name
01	Read Coils Status
02	Read Discrete Inputs
03	Read Holding Registers
04	Read Input Registers
05	Write Single Coil
06	Write Single Register
08	Diagnostic
15 (0F Hex)	Write Multiple Coils
16 (10 Hex)	Write Multiple Registers
17 (11 Hex)	Report slave ID
20 (14 Hex)	Read File Record

8.1 Function Code 01 (0x01) Read Coils Status

References 0x

This function code is used to read the status of contiguous coils in a slave device. Status of coils is indicated as 1 = ON and 0 = OFF. Modbus RTU Interface has implemented 11 coils.

If quantity of coils requested is less than 1 or more than 11, the Exception Code 03 (0x03) is generated.

If the combination of the starting address and the quantity of coils requested is more than 11, the Exception Code 02 (0x02) is generated.

If an error occurs while the slave device is performing the action requested in the query, Exception Code 04 (0x04) is generated.

If slave device is engaged to complete a request from the logic card, Exception Code 06 (0x06) is generated.

Broadcast messages are not allowed.

The list of the coils implemented in the Modbus RTU Interface is described in Section 7.2.

Example of a request to read coils 1 - 4 from device 12:

Table 7. Request

Field Name	Value (HEX)
Address	0C
Function Code	01
Start address Hi	00
Start address Lo	00
Quantity of Outputs Hi	00
Quantity of Outputs Lo	04
CRC	-

Table 8. Response

Field Name	Value (HEX)
Address	0C
Function Code	01
Byte Count	01
Output Status Address 3 - 0*	00
CRC	-

NOTE:

* bits 7 - 5 should be zero filled.

8.2 Function Code 02 (0x02) Read Discrete Inputs

References 1x

This function code is used to read from 1 to 2000 contiguous status of discrete inputs in a slave device. Status of discrete inputs is indicated as 1 = ON and 0 = OFF. Modbus RTU Interface has implemented 32 discrete inputs.

If quantity of inputs requested is less than 1 or more than 32, the Exception Code 03 (0x03) is generated.

If the combination of the starting address and the quantity of inputs requested is more than 32, the Exception Code 02 (0x02) is generated.

If an error occurs while the slave device is performing the action requested in the query, Exception Code 04 (0x04) is generated.

If slave device is engaged to complete a request from the logic card, Exception Code 06 (0x06) is generated.

Broadcast messages are not allowed.

The list of the discrete inputs implemented in the Modbus RTU Interface is described in Section 7.1.

Example of a request to read discrete inputs 2 - 13 from device 18:

Table 9. Request

Field Name	Value (HEX)
Address	12
Function Code	02
Start address Hi	00
Start address Lo	01
Quantity of Inputs Hi	00
Quantity of Inputs Lo	0C
CRC	-

Table 10. Response

Function Code	Modbus Name
Address	12
Function Code	02
Byte Count	02
Input Status Address 9 - 1	00
Input Status Address 13 - 10*	00
CRC	-

NOTE:

* bits 7 - 4 are zero filled.

8.3 Function Code 03 (0x03) Read Holding Registers

References 4x

This function code is used to read the contents of a contiguous block of holding registers (from 1 to 125) in a slave device.

If quantity of registers requested is less than 1 or more than 125, Exception Code 03 (0x03) is generated.

If an error occurs while the slave device is performing the action requested in the query, Exception Code 04 (0x04) is generated.

If slave device is engaged to complete a request from the logic card, Exception Code 06 (0x06) is generated.

Broadcast messages are not allowed.

The list of the holding registers implemented in the Modbus RTU Interface is described in Section 7.4.

Example of a request to read Holding Registers 1 - 2 from device 13:

Table 11.

Field Name	Value (HEX)
Address	0D
Function Code	03
Start address Hi	00
Start address Lo	00
Quantity of Register Hi	00
Quantity of Register Lo	02
CRC	-

Table 12.

Field Name	Value (HEX)
Address	0D
Function Code	03
Byte Count	04
Holding Register Address 0 Hi	-
Holding Register Address 0 Low	-
Holding Register Address 1 Hi	-
Holding Register Address 1 Low	-
CRC	-

8.4 Function Code 04 (0x04) Read Input Registers

References 3x

This function is used to read from 1 to 125 contiguous input registers in a slave device.

Modbus RTU Interface has implemented 369 input registers.

If quantity of registers requested is less than 1 or more than 125, Exception Code 03 (0x03) is generated.

If the combination of the starting address and the quantity of registers requested is more than 369, Exception Code 02 (0x02) is generated.

If an error occurs while the slave device is performing the action requested in the query, Exception Code 04 (0x04) is generated.

If slave device is engaged to complete a request from the logic card, Exception Code 06 (0x06) is generated.

Broadcast messages are not allowed.

The list of the input registers implemented in the Modbus RTU Interface is described in Section 7.3.

Example of a request to read Input Registers 5 - 16 (Address 4 - 15) from device 4:

Table 13. Request

Field Name	Value (HEX)
Address	04
Function Code	04
Start address Hi	00
Start address Lo	04
Quantity of Register Hi	00
Quantity of Register Lo	0C
CRC	-

Table 14. Response

Field Name	Value (HEX)
Address	04
Function Code	04
Byte Count	18
Input Register Address 04 Hi	-
Input Register Address 04 Low	-
Input Register Address 05 Hi	-
Input Register Address 05 Low	-
Input Register Address 06 Hi	-
Input Register Address 06 Low	-
-	-
Input Register Address 0E Hi	-
Input Register Address 0E Low	-
Input Register Address 0F Hi	-
Input Register Address 0F Low	-
CRC	-

8.5 Function Code 05 (0x05) Write Single Coil

References 0x

This function is used to write a single coil to either ON or OFF in a remote device. Modbus RTU Interface has implemented 11 coils.

If coil address is more than 10, Exception Code 02 (0x02) is generated.

If coil value in data field is different from 0xFF00 or 0x0000, Exception Code 03 (0x03) is generated.

If an error occurs while the slave device is performing the action requested in the query, Exception Code 04 (0x04) is generated.

If slave device is engaged to complete a request from the logic card, Exception Code 06 (0x06) is generated.

Broadcast messages are allowed, no response is generated after a broadcast request.

The list of the coils implemented in the Modbus RTU Interface is described in Section 7.2 See Section 11 for details about the writing rules of the Modbus data.

The commands can be sent to the actuator also with Function Codes 06 (Write Single Register), 15 (Write Multiple Coils) and 16 (Write Multiple Registers); it is recommended to verify the absence of conflict between commands from coils and commands from registers.

Example of a request to write coil 1 (address 0) in the slave device 12:

Table 15. Request

Field Name	Value (HEX)
Address	0C
Function Code	05
Output address Hi	00
Output address Lo	00
Output Value Hi	FF
Output Value Lo	00
CRC	-

Table 16. Response

Field Name	Value (HEX)
Address	0C
Function Code	05
Output Address Hi	00
Output Address Lo	00
Output Value Hi	FF
Output Value Lo	00
CRC	-

8.6 Function Code 06 (0x06) Write Single Register

References 4x

This function code is used to write a value of a single holding register in a remote device. Modbus RTU Interface has implemented 22 holding registers.

If value of register is out of range (see Table 17 for details), Exception Code 03 (0x03) is generated.

If an error occurs while the slave device is performing the action requested in the query, Exception Code 04 (0x04) is generated.

If slave device is engaged to complete a request from the logic card, Exception Code 06 (0x06) is generated.

Broadcast messages are allowed, no response is generated after a broadcast request.

The list of the holding registers implemented in the Modbus RTU Interface is described in Section 7.4. See Section 11 for details about the writing rules of the Modbus data.

The commands can be sent to the actuator also with Function Codes 05 (Write Single Coil), 15 (Write Multiple Coils) and 16 (Write Multiple Registers); it is recommended to verify the absence of conflict between commands from coils and commands from registers.

Example of a request to write Holding Register 1 (address 0) in the field device 15:

Table 17. Request

Field Name	Value (HEX)
Address	0F
Function Code	06
Register address Hi	00
Register address Lo	00
Register Value Hi	00
Register Value Lo	02
CRC	-

Table 18. Response

Field Name	Value (HEX)
Address	0F
Function Code	06
Output Address Hi	00
Output Address Lo	00
Output Value Hi	00
Output Value Lo	02
CRC	-

8.7 Function Code 08 (0x08) Diagnostic

This function code provides a certain number of tests to check the communication system between a master and a slave device, or for checking various internal error conditions within a slave.

The type of test to be executed can be selected using the two bytes sub-function code field in the query.

If sub-function code is not supported, Exception Code 01 (0x01) is generated.

If data field value is not valid, Exception Code 03 (0x03) is generated.

If an error occurs while the slave device is performing the action requested in the query, Exception Code 04 (0x04) is generated.

If slave device is engaged to complete a request from the logic card, Exception Code 06 (0x06) is generated.

Broadcast messages are not allowed.

The sub-functions implemented in the Modbus RTU Interface are:

Table 19.

Sub-Function Code	Name
0 (0x0000)	Return Query Data
11 (0x000B)	Return Bus Message Count
12 (0x000C)	Return Bus Communication Error Count
13 (0x000D)	Return Bus Exception Error Count
14 (0x000E)	Return Slave Message Count
17 (0x0011)	Return Slave Busy Count
18 (0x0012)	Return Bus Character Overrun Count

8.7.1 Sub-Function 00 (0x0000) Return Query Data

The data passed in the request data field is to be returned (looped back) in the response. The entire response message should be identical to the request.

Any value of the Data Field in the request is valid.

The Data Field in the response is the echo of the Data Field in the request.

8.7.2 Sub-Function 11 (0x000B) Return Bus Message Count

The response data field returns the quantity of messages that the slave device has detected on the communications system since its last restart, clear counters operation, or power up.

Only 0x0000 code is valid in the request data field, otherwise Exception Code 03 (0x03) is generated.

8.7.3 Sub-Function 12 (0x000C) Return Bus Communication Error Count

The response data field returns the quantity of Modbus exception responses returned by the slave device since its last restart, clear counters operation, or power up.

Only 0x0000 code is valid in the request data field, otherwise Exception Code 03 (0x03) is generated.

8.7.4 Sub-Function 13 (0x000D) Return Bus Exception Error Count

The response data field returns the quantity of Modbus exception responses returned by the slave device since its last restart, clear counters operation, or power up.

Only 0x0000 code is valid in the request data field, otherwise Exception Code 03 (0x03) is generated.

8.7.5 Sub-Function 14 (0x000E) Return Slave Message Count

The response data field returns the quantity of messages addressed to the slave device or broadcast, that the slave device has processed since its last restart, clear counters operation, or power up.

Only 0x0000 code is valid in the request data field, otherwise Exception Code 03 (0x03) is generated.

8.7.6 Sub-Function 17 (0x0011) Return Slave Busy Count

The response data field returns the quantity of messages addressed to the remote device for which it returned a Slave Device Busy exception response, since its last restart, clear counters operation, or power up.

Only 0x0000 code is valid in the request data field, otherwise Exception Code 03 (0x03) is generated.

8.7.7 Sub-Function 18 (0x0012) Return Bus Character Overrun Count

The response data field returns the quantity of messages addressed to the slave device that it could not handle due to a character overrun condition, since its last restart, clear counters operation, or power up.

Only 0x0000 code is valid in the request data field, otherwise Exception Code 03 (0x03) is generated.

Example of a request to Return Query Data to the slave device 22:

Table 20. Request

Field Name	Value (HEX)
Address	16
Function Code	08
Sub-Function Code Hi	00
Sub-Function Code Lo	00
Data Hi	A5
Data Lo	B6
CRC	-

Table 21. Response

Field Name	Value (HEX)
Address	16
Function Code	08
Sub-Function Code Hi	00
Sub-Function Code Lo	00
Data Hi	A5
Data Lo	B6
CRC	-

8.8 Function Code 15 (0x0F) Write Multiple Coils

This function code is used to write the coils indicated in the query to ON or OFF state. Modbus RTU Interface has implemented 11 coils.

If quantity of coils is less than 1 or more than 11, Exception Code 03 (0x03) is generated.

Exception code 03 (0x03) is also generated if the byte count value is not correct.

If starting address or its combination with the quantity of coils is more than 11, Exception Code 02 (0x02) is generated.

If an error occurs while the slave device is performing the action requested in the query, Exception Code 04 (0x04) is generated.

If slave device is engaged to complete a request from the logic card, Exception Code 06 (0x06) is generated.

Broadcast messages are allowed, no response is generated after a broadcast request.

The list of the coils implemented in the Modbus RTU Interface is described in Section 7.2. See Section 11 for details about the writing rules of the Modbus data.

The commands can be sent to the actuator also with Function Codes 05 (Write Single Coil), 06 (Write Single Register) and 16 (Write Multiple Registers); it is recommended to verify the absence of conflict between commands from coils and commands from registers.

Example of a request to write coils 1 - 5 (address 0 - 4) to device 3:

Table 22. Request

Field Name	Value (HEX)
Address	03
Function Code	0F
Starting Address Hi	00
Starting Address Lo	00
Quantity of Coils Hi	00
Quantity of Coils Lo	05
Byte Count	01
Coils Value (data bits 7 - 0)*	08
CRC	-

NOTE:

*bits 7 - 5 should be zero filled.

Table 23. Response

Field Name	Value (HEX)
Address	03
Function Code	0F
Starting Address Hi	00
Starting Address Lo	00
Quantity of Coils Hi	00
Quantity of Coils Lo	05
CRC	-

8.9 Function Code 16 (0x10) Write Multiple Registers

This function code is used to write a block of contiguous registers in a slave device.

If quantity of registers is less than 1 or more than 123, Exception code 03 (0x03) is generated.

Exception Code 03 (0x03) is also generated if byte count field is not twice of the value of quantity of registers.

If an error occurs while the slave device is performing the action requested in the query, Exception Code 04 (0x04) is generated.

If slave device is engaged to complete a request from the logic card, Exception Code 06 (0x06) is generated.

Broadcast messages are allowed, no response is generated after a broadcast request.

The list of the holding registers implemented in the Modbus RTU Interface is described in Section 7.4. See Section 11 for details about the writing rules of the Modbus data.

The commands can be sent to the actuator also with Function Codes 05 (Write Single Coil), 06 (Write Single Register) and 15 (Write Multiple Coils); it is recommended to verify the absence of conflict between commands from coils and commands from registers.

Example of a request to write holding registers 1 - 4 (address 0 - 3) to device 2:

Table 24. Request

Field Name	Value (HEX)
Address	02
Function Code	10
Starting Address Hi	00
Starting Address Lo	00
Quantity of Registers Hi	00
Quantity of Registers Lo	03
Byte Count	06
Register Value Hi (address 0)	00
Register Value Lo (address 0)	04
Register Value Hi (address 1)	01
Register Value Lo (address 1)	F4
Register Value Hi (address 2)	00
Register Value Lo (address 2)	0A
CRC	-

Table 25. Response

Field Name	Value (HEX)
Address	02
Function Code	10
Starting Address Hi	00
Starting Address Lo	00
Quantity of Registers Hi	00
Quantity of Registers Lo	03
CRC	-

8.10 Function Code 17 (0x11) Report Slave ID

This function code is used to read the information relevant to the type of slave device.

Modbus RTU Interface returns information about actuator type, actuator serial number, valve tag name, and software revision.

82 bytes of additional data are returned; each byte of the Additional Data contains an ASCII character.

If an error occurs while the slave device is performing the action requested in the query, Exception Code 04 (0x04) is generated.

If slave device is engaged to complete a request from the logic card, Exception Code 06 (0x06) is generated.

Broadcast messages are not allowed.

The following tables describe the additional data field for ICON3000 and F01 actuators:

Table 26. Additional Data Field for ICON3000 Actuator

Data Bytes	Description
0 - 15	"Biffi ICON3000" (Act. Type)
16 - 43	Actuator Serial Number
44 - 71	Valve Tag Name
72 - 75	Base Card Software Revision
76 - 77	Blank characters
78 - 81	Modbus Interface SW Revision
CRC	-

Table 27. Additional Data Field for F01 Actuator

Data Bytes	Description
0 - 15	"BIFFI F01 3000" (Act. Type)
16 - 43	Actuator Serial Number
44 - 71	Valve Tag Name
72 - 75	Base Card Software Revision
76 - 77	Blank characters
78 - 81	Modbus Interface SW Revision
CRC	-

Example of a request of Report Slave ID to device 8 (ICON3000 actuator):

Table 28. Request

Field Name	Value (HEX)
Address	08
Function Code	11
CRC	-

Table 29. Response

Field Name	Value (HEX)
Address	08
Function Code	11
Byte Count	52
Slave ID	00
Run Indicator Status	00
Actuator Type (16 bytes)	-
Actuator Serial Number (28 bytes)	-
Valve Tag Name (28 bytes)	-
Base Card SW Revision (4 bytes)	-
Blank Characters (2 byte)	-
Interface SW Revision (4 bytes)	-
CRC	-

8.11 Function Code 20 (0x14) Read File Record

This function code is available only in ICON3000v2 actuator and is used to read a file record.

A file is an organization of records. Each file contains 10000 records, addressed from 0 to 9999.

The function can read multiple groups of references. The groups can be separating (non-contiguous), but the references within each group must be sequential.

Each group is defined in a separate “sub-request” field that contains 7 bytes:

Reference Type: 1 byte (must be specified as 6)

File number: 2 bytes

Starting record number: 2 bytes

Length of the record to be read: 2 bytes

The quantity or registers to be read, combined with all other fields in the expected response, must not exceed the allowable length of the Modbus PDU: 253 bytes

Table 30 shows the File Numbers supported by Modbus RTU Interface:

Table 30.

Field Number	Value (HEX)
2	Alarms Log
3	Warnings Log
4	Connection Logs
5	HR Limits
1000 - 1100	FST Open Torque Curves
2000 - 2100	FST Close Torque Curves
3000 - 3016	PST Curves
3500 - 3516	EFS Curves
5000	Events Log
5100	Recorder Log
5200	T-Recorder Log
5300 - 5304	Cards Report

8.11.1 File Number 2: Alarms Log

Table 31 shows the Alarm Log file structure:

Table 31.

Record Number	Description
0	Number of Alarms Stored
1	Alarm 1 Date and Time (MSB)
2	Alarm 1 Date and Time (LSB)
3	Alarm 1 ID
4	Alarm 2 Date and Time (MSB)
5	Alarm 2 Date and Time (LSB)
6	Alarm 2 ID
-	-
-	-
-	-
n	Alarm N Date and Time (MSB)
n + 1	Alarm N Date and Time (LSB)
n + 2	Alarm N ID

Alarms are sorted by date; Alarm 1 is the most recent.

“Date and Time” data is expressed in seconds starting from 01/01/2000 00:00.

Table 32 shows the Alarm ID values:

Table 32.

Value	Description
0	None
1	Configuration
2	Thermostat
3	Over Temperature
4	Low Battery
5	Hi-Hi Torque in Close
6	Alarm 2 ID
6	Hi-Hi Torque in Open
7	Jammed Valve in Close
8	Jammed Valve in Open
9	Position Sensor
10	Speed Sensor
11	Main Supply
12	Lost Phase
13	K1 Contactor
14	K2 Contactor
15	Mid Travel in Close
16	Mid Travel in Open
17	Hardware 1
18	Request Signal
19	Direction Test
20	Hardware 2
21	Hardware 3
22	Hardware 4
23	Hardware 5
24	Hardware 6
25	Hardware 7
26	Hardware 8

Value	Description
27	Hardware 9
28	Hardware 10
29	EFS Mid Travel
30	Hardware 11
31	Hardware 12
32	Hardware 13

Each Alarm occupies 3 Records.

The file length is equal to (“Number of Alarm Stored” * 6) + 2.

8.11.2 File Number 3: Warnings Log

Table 33 shows the Warnings Log file structure:

Table 33.

Record Number	Description
0	Number of Warnings Stored
1	Warning 1 Date and Time (MSB)
2	Warning 1 Date and Time (LSB)
3	Warning 1 ID
4	Warning 2 Date and Time (MSB)
5	Warning 2 Date and Time (LSB)
6	Warning 2 ID
-	-
-	-
-	-
n	Warning N Date and Time (MSB)
n + 1	Warning N Date and Time (LSB)
n + 2	Warning N ID

Warnings are sorted by date, Warning 1 is the most recent.

“Date and Time” data is expressed in seconds starting from 01/01/2000 00:0.

Table 34 shows the Warning ID values 0:

Table 34.

Value	Description
0	None
1	Hi Torque in Opening
2	Hi Torque in Closing
3	Over Temperature
4	Main Supply
5	Max. Contactor Cycles
6	Maintenance Request
7	Motor Current
8	Wrong Stroke Limits
9	Bus
10	PST
11	PST Failed - T1
12	PST Failed - T2
13	PST Failed - Over Travel

Each Warning occupies 3 Records.

The file length is equal to (“Number of Warnings Stored” * 6) + 2.

8.11.3 File Number 4: Connections Log

Table 35 shows the Connection Log file structure:

Table 35.

Record Number	Description
0	Number of Connections Stored
1	Connection Log 1 - Password Level
2 - 13	Connection Log 1 - Pda/PC ID
14 - 25	Connection Log 1 - Operator ID
26 - 29	Connection Log 1 - Spare, Not Used
30	Connection Log 1 - Device (0 = Bluetooth, 1 = RS232)
31	Connection Log 1 - Date and Time (MSB)
32	Connection Log 1 - Date and Time (LSB)
-	-
-	-
n	Connection Log N - Password Level
n + 1	Connection Log N - Pda/PC ID
n + 2	Connection Log N - Operator ID
n + 3	Connection Log N - Spare, Not Used
n + 4	Connection Log N - Device (0 = Bluetooth, 1 = RS232)
n + 5	Connection Log N - Date and Time (MSB)
n + 6	Connection Log N - Date and Time (LSB)

Connections are sorted by date; Connection 1 is the most recent.

“Date and Time” data is expressed in seconds starting from 01/01/2000 00:00.

Table 36 shows the Password Level values:

Table 36.

Value	Description
0	Observer
1	User
2	Service
3	Manufacturer

Each connection occupies 32 Records.

The file length is equal to (“Number of Connections Stored” * 64) + 2.

8.11.4 File Numbers from 1000 to 1100: FST Open Torque Curves

File Number 1000 indicates the FST Open Torque Reference Curve.

The FST Open Torque Curves from file number 1001 to 1100 are sorted by date.

File Number 1001 indicates the most recent FST Open Curve.

File Number 1100 indicates the older FST Open Curve.

Table 37 shows the Warning ID values 0:

Table 37.

Record Number	Description
0	Torque at position 0%
1	Torque at position 1%
2	Torque at position 2%
3	Torque at position 3%
4	Torque at position 4%
-	-
98	Torque at position 98%
99	Torque at position 99%
100	Torque at position 100%
101	Date and Time (MSB)
102	Date and Time (LSB)
103	Electronic Temperature (°C)
104	Terminal Board Temperature (°C)
105	Motor Temperature (°C)
106	Voltage
107	Stroke Time (second)

“Date and Time” data is expressed in seconds starting from 01/01/2000 00:00.
Each FST Open Torque Curve occupies 108 Records.

8.11.5 File Numbers from 2000 to 2100: FST Close Torque Curves

File Number 2000 indicates the FST Close Torque Reference Curve.

The FST Close Torque Curves from file number 2001 to 2100 are sorted by date.

File Number 2001 indicates the most recent FST Close Curve.

File Number 2100 indicates the older FST Close Curve.

Table 38 shows the FST Close Torque Curve File structure:

Table 38.

Record Number	Description
0	Torque at position 0%
1	Torque at position 1%
2	Torque at position 2%
3	Torque at position 3%
4	Torque at position 4%
-	-
98	Torque at position 98%
99	Torque at position 99%
100	Torque at position 100%
101	Date and Time (MSB)
102	Date and Time (LSB)
103	Electronic Temperature (°C)
104	Terminal Board Temperature (°C)
105	Motor Temperature (°C)
106	Voltage
107	Stroke Time (seconds)

“Date and Time” data is expressed in seconds starting from 01/01/2000 00:00.
Each FST Close Torque Curve occupies 108 Records.

8.11.6 File Numbers from 3000 to 3016: PST Curves

File Number 3000 indicates the PST Reference Curve.

The PST Curves from file number 3001 to 3016 are sorted by date.

File Number 3001 indicates the most recent PST Curve.

File Number 3016 indicates the older PST Curve.

Table 39 shows the PST Curve File structure:

Table 39.

Record Number	Description	Eng. Unit
0	T-PST: Elapsed time from PST command	s/10
1	T-PST: Elapsed time to reach position 1% (Open PST) or position 99% (Close PST)	s/10
2	T-PST: Elapsed time to reach position 2% (Open PST) or position 98% (Close PST)	s/10
3	T-PST: Elapsed time to reach position 3% (Open PST) or position 97% (Close PST)	s/10
4	T-PST: Elapsed time to reach position 4% (Open PST) or position 96% (Close PST)	s/10
-	-	s/10
48	T-PST: Elapsed time to reach position 48% (Open PST) or position 52% (Close PST)	s/10
49	T-PST: Elapsed time to reach position 49% (Open PST) or position 51% (Close PST)	s/10
50	T-PST: Elapsed time to reach position 50% (Open PST) or position 50% (Close PST)	s/10
51	T-RET: Elapsed time to reach position 1% (Open PST) or position 99% (Close PST)	s/10
52	T-RET: Elapsed time to reach position 2% (Open PST) or position 98% (Close PST)	s/10
53	T-RET: Elapsed time to reach position 3% (Open PST) or position 97% (Close PST)	s/10
54	T-RET: Elapsed time to reach position 4% (Open PST) or position 96% (Close PST)	s/10
-	-	s/10
98	T-RET: Elapsed time to reach position 48% (Open PST) or position 52% (Close PST)	s/10
99	T-RET: Elapsed time to reach position 49% (Open PST) or position 51% (Close PST)	s/10
100	T-RET: Elapsed time to reach position 50% (Open PST) or position 50% (Close PST)	s/10
101	Date and Time (MSB)	s
102	Date and Time (LSB)	s
103	Electronic Temperature	°C
104	Terminal Board Temperature	°C
105	Motor Temperature/Speed	°C
106	EFS Card Temperature	°C
107	Voltage	V
108	PST Result. See Note 1	-
109	PST Direction. See Note 2	-
110	T-PST	s/10
111	T-RET	s/10
112	OV-TR (1 = 0,1%)	%
113	PST Travel Limit	%
114	PST Mode. See Note 3	-
115	PST Status. See Note 4	-
116	PST Reset Conditions (MSB). See Note 5	-
117	PST Reset Conditions (LSB). See Note 5	-

NOTES:

PST Result:

Value	Description
1	Passed
2	Failed
3	Reset
4	T-PST
5	T-RET
6	OV-TR

PST Direction:

Value	Description
0	PST Close (Start from 100%)
1	PST Open (Start from 0%)

PST Mode:

Value	Description
0	Off
1	Auto
2	Manual
3	Manual + Auto

PST Status:

Bits	Description
b5 - b31	Not Used
b4	1 = PST Reset
b3	1 = PST Failed - OV-TR
b2	1 = PST Failed - T-RET
b1	1 = PST Failed - T-PST
b0	1 = PST Passed

PST Reset Conditions:

Bits	Description
b17 - b31	Not Used
b16	Hardware 1 Alarm
b15	K2 Contactor Alarm
b14	1 = K1 Contactor Alarm
b13	1 = Speed Sensor Alarm
b12	1 = Hi Torque Alarm
b11	1 = Jammed Valve Alarm
b10	1 = Hi Temperature Alarm
b9	1 = Lost Phase Alarm
b8	1 = Main Supply Alarm
b7	1 = Thermostat Alarm
b6	1 = Position Sensor Alarm
b5	1 = Configuration Alarm
b4	1 = Fail-Safe
b3	1 = ESD
b2	1 = Remote Stop
b1	1 = Local Stop
b0	1 = Selector in Off

“Date and Time” data is expressed in seconds starting from 01/01/2000 00:00.

Each PST Curve occupies 118 Records.

8.11.7 File Numbers from 3500 to 3516: EFS Curves

File Number 3500 indicates the EFS Reference Curve.

The EFS Curves from file number 3501 to 3516 are sorted by date.

File Number 3501 indicates the most recent EFS Curve.

File Number 3516 indicates the older EFS Curve.

Table 40 shows the EFS Curve File structure:

Table 40.

Record Number	Description	Eng. Unit
0	T-EFS: Elapsed time from EFS command	s/10
1	T-EFS: Elapsed time to reach position 1% (Open EFS) or position 99% (Close EFS)	s/10
2	T-EFS: Elapsed time to reach position 2% (Open EFS) or position 98% (Close EFS)	s/10
3	T-EFS: Elapsed time to reach position 3% (Open EFS) or position 97% (Close EFS)	s/10
4	T-EFS: Elapsed time to reach position 4% (Open EFS) or position 96% (Close EFS)	s/10
-	-	s/10
98	T-EFS: Elapsed time to reach position 98% (Open EFS) or position 2% (Close EFS)	s/10
99	T-EFS: Elapsed time to reach position 99% (Open EFS) or position 1% (Close EFS)	s/10
100	T-EFS: Elapsed time to reach position 100% (Open EFS) or position 0% (Close EFS)	s/10
101	Date and Time (MSB)	seconds
102	Date and Time (LSB)	seconds
103	Electronic Temperature	°C
104	Terminal Board Temperature	°C
105	Motor Temperature/Speed	°C
106	EFS Card Temperature	°C
107	Voltage	V
108	Reserved - Not Used	-
109	EFS Direction (See Note 1)	-

Notes:

EFS Direction:

Value	Description
0	EFS Close (Start from 100%)
1	EFS Open (Start from 0%)

“Date and Time” data is expressed in seconds starting from 01/01/2000 00:00.

Each EFS Curve occupies 110 Records.

8.11.8 File Number 5000: Events Log

Table 41 shows the EFS Curve File structure:

Table 41.

Record Number	Description
0	Number of Events Stored
1	Recording Start Date and Time (MSB)
2	Recording Start Date and Time (LSB)
3	Memory Mode
4	Event 1 Date and Time (MSB)
5	Event 1 Date and Time (LSB)
6	Event 1 Code
7	Event 1 Source
8	Event 1 - Not Used
9	Event 2 Date and Time (MSB)
10	Event 2 Date and Time (LSB)
11	Event 2 Code
12	Event 2 Source
13	Event 2 - Not Used
-	-
n	Event N Date and Time (MSB)
n + 1	Event N Date and Time (LSB)
n + 2	Event N Code
n + 3	Event N Source
n + 4	Event N - Not Used

Events are sorted by date; Event 1 is the most recent.

“Date and Time” data is expressed in seconds starting from 01/01/2000 00:00.

Table 42 shows the Memory Mode values:

Table 42.

Value	Description
0	Continuous
1	Stop when full

Table 43 shows the Event Code values:

Table 43.

Value	Description
0	Off
1	Open
2	Close

Table 44 shows the Event Source values:

Table 44.

Value	Description
0	None
1	Bus Command
2	Remote Command
3	Local Command
4	ESD
5	Position Calibration
6	Torque Calibration
7	Fail-Safe
8	Position Request from bus
9	Position Request from 4 - 20 mA Input
10	Serial/Bluetooth command
11	Start Positioner Mode
12	Stop Positioner Mode
13	Movement without electrical signal
14	K1 Contactor fail
15	K2 Contactor fail
16	Configuration On
17	PST
18	EFS Fail-Safe
19	Reserved
20	Reserved
21	Power Up
22	Selector moved from REMOTE to LOCAL/OFF
23	STOP in Remote

Each Event occupies 5 Records.

The file length is equal to ("Number of Event Stored" * 10) + 8.

8.11.9 File Number 5100: Recorders Log

Table 45 shows the Recorders Log File structure:

Table 45.

Record Number	Description
0	Number of Recorders Stored
1	Recording Start Date and Time (MSB)
2	Recording Start Date and Time (LSB)
3	Memory Mode
4	Sample Interval
5	Recorder 1 - Date and Time (MSB)
6	Recorder 1 - Date and Time (LSB)
7	Recorder 1 - Electronic Temperature
8	Recorder 1 - Motor Temperature
9	Recorder 1 - Voltage
10	Recorder 1 - Not Used
11	Recorder 2 - Date and Time (MSB)
12	Recorder 2 - Date and Time (LSB)
13	Recorder 2 - Electronic Temperature
14	Recorder 2 - Motor Temperature
15	Recorder 2 - Voltage
16	Recorder 2 - Not Used
-	-
n	Recorder N - Date and Time (MSB)

Record Number	Description
n + 1	Recorder N - Date and Time (LSB)
n + 2	Recorder N - Electronic Temperature
n + 3	Recorder N - Motor Temperature
n + 4	Recorder N - Voltage
n + 5	Recorder N - Not Used

Recorders are sorted by date; Recorder 1 is the most recent.

“Date and Time” data is expressed in seconds starting from 01/01/2000 00:00.

“Sample Interval” is expressed in seconds.

Temperature data is expressed in °C; the range value is -127 °C - 128 °C.

“Voltage” data is expressed in V.

Table 46 shows the Memory Mode values:

Table 46.

Value	Description
0	Continuous
1	Stop when full

Each Recorder occupies 6 Records.

The file length is equal to (“Number of Recorders Stored” * 12) + 10.

8.11.10 File Number 5200: T-Recorders Log

Table 47 shows the T-Recorders Log file structure:

Table 47.

Record Number	Description
0	Number of T-Recorders Stored
1	Recording Start Date and Time (MSB)
2	Recording Start Date and Time (LSB)
3	Memory Mode
4	Sample Interval
5	T-Recorder 1 - Date and Time (MSB)
6	T-Recorder 1 - Date and Time (LSB)
7	T-Recorder 1 - Torque
8	T-Recorder 1 - Motor Temperature
9	T-Recorder 1 - Voltage
10	T-Recorder 1 - Not Used
11	T-Recorder 2 - Date and Time (MSB)
12	T-Recorder 2 - Date and Time (LSB)
13	T-Recorder 2 - Torque
14	T-Recorder 2 - Motor Temperature
15	T-Recorder 2 - Voltage
16	T-Recorder 2 - Not Used
-	-
n	T-Recorder N - Date and Time (MSB)
n + 1	T-Recorder N - Date and Time (LSB)
n + 2	T-Recorder N - Torque
n + 3	T-Recorder N - Motor Temperature
n + 4	T-Recorder N - Voltage
n + 5	T-Recorder N - Not Used

Recorders are sorted by date; Recorder 1 is the most recent.

“Date and Time” data is expressed in seconds starting from 01/01/2000 00:00.

“Sample Interval” is expressed in seconds.

Torque data is expressed in percentage; the range value is 0% - 100%.

Temperature data is expressed in °C; the range value is -127 °C - 128 °C.

Voltage data is expressed in V.

Table 48 shows the Memory Mode values:

Table 48.

Value	Description
0	Continuous
1	Stop when full

Each T-Recorder occupies 6 Records.

The file length is equal to (“Number of T-Recorders Stored” * 12) + 10.

8.11.11 File Numbers from 5300 to 5304: Cards Report

File Number 5300 indicates the Base Card Report.

File Number 5301 indicates the 4 - 20 mA Card Report.

File Number 5302 indicates the Terminal Board Card Report.

File Number 5303 indicates the EFS Card Report.

File Number 5304 indicates Modbus Interface Card Report.

Table 49 shows the Cards Report structure:

Table 49.

Record Number	Description
0	Card Code (1/5, MSB)
1	Card Code (2/5)
2	Card Code (3/5)
3	Card Code (4/5)
4	Card Code (5/5, LSB)
5	Not Used
6	Product Week
7	Product Year
8	Serial Number (1/3, MSB)
9	Serial Number (2/3)
10	Serial Number (3/3, LSB)
11	HW and FW Revision (1/5, MSB)
12	HW and FW Revision (2/5)
13	HW and FW Revision (3/5)
14	HW and FW Revision (4/5)
15	HW and FW Revision (5/5, LSB)
16 - 31	Free Text

All Records data format is ASCII.

8.12 Exception Codes

When a master sends a request to a slave, it expects a response. The following cases may occur:

- The slave receives the request and returns the normal response.
- The slave does not receive the request and no response is returned. In this case the master waits for a certain time (timeout) and then it restarts with a new request.
- The slave receives the request but detects a communication error (CRC). In this case the slave does not return a response; the master waits for a certain time (timeout) and then it restarts with a new request.
- The slave receives the request without communication error, but it cannot process the data. In this case the slave returns an Exception Error message that describes the error.

Modbus RTU Interface has implemented the following Exception Codes:

Table 50.

Exception Code	Name	Description
01	Illegal Function Code	The function code requested is not supported in the slave device selected.
02	Illegal Data Address	The data address contained in the request message is not allowable in the slave device, or the combination of reference number and transfer length is invalid.
03	Illegal Data Value	A value contained in the request data field is not valid for the slave device.
04	Slave Device Failure	An error occurred while the slave device was performing the action requested by the request.
06	Slave Device Busy	The slave device is busy. The master should retransmit the request later.

Section 9: Configuration via Local Interface

The Modbus RTU Interface is an additional module that allows connecting the ICON3000 actuators family to a Modbus RTU fieldbus. Here below are described the facilities available by the view and setup menu of the actuator in which the Modbus RTU Interface is installed.

9.1 BUS Control

9.1.1 Settings for ICON2000v4 and ICON3000 Actuators

DIN 1 - DIN 6: by this routine it is possible to choose the condition associated to bits 8 - 13 of function code 02 (read input status). Here are the lists of the available conditions:

Status

- Open limit
- Closed limit
- Position \geq xx %
- Position \leq xx %
- Closing
- Opening
- Motor running
- Blinker
- Mid-travel position
- Local selected
- Remote selected
- Local stop active
- ESD signal on
- Manual operation

Alarm

- Motor over-temperature
- Over-torque
- Over-torque in OP
- Over-torque in CL
- Valve jammed
- Warnings
- Valve jammed in OP
- Valve jammed in CL
- Low alkaline battery (if present)
- Mid travel alarm in CL/OP

The following setting is supplied as standard:

- DIN 1: mid travel position
- DIN 2: local stop active
- DIN 3: motor over-temperature (motor thermostat alarm)
- DIN 4: over-torque (Hi-Hi torque alarm)
- DIN 5: valve jammed alarm
- DIN 6: mid travel alarm in OP/CL
- Baud rate: by this function it is possible to set the transmission speed. All devices on the same data line must have the same transmission speed.
- Parity: this routine allows to choose the parity in the Modbus RTU message (ODD, EVEN, NO PARITY).
- Node: by this function it is possible to enter the node address. Each device must have its address. Each address must be associated to one only device. The available address range is from 1 to 247.
- Termin 1 status: by this routine the internal termination of channel 1 can be connected to the BUS line (ON/OFF). Set "termin 1 = ON" only if the actuator is at the begin or at the end of the BUS line and if channel 1 is selected.
- Termin 2 status: by this routine the internal termination of channel 2 can be connected to the BUS line (ON/OFF). Set "termin 2 = OFF" if single BUS line is used.
- Mode: by this routine the channel 1 or channel 2 are enabled to work. The option is used only when redundant cable is requested. Set "mode = CH1" if single BUS line is used.

Configuration Procedure:

- Move the local selector to OFF and then press simultaneously OPEN and STOP. Select the language and then enter the password according to the instructions "entering the setup mode". When the message of display is "SETUP MODE OK?" press YES. Press YES to select actuator setup menu, press NO to scroll the list of available routines and then press YES to select BUS CONTROL.
- Press YES if the condition linked to DIN 1 is correct, or press NO to change, then press YES.
- Repeat the previous step for DIN 2, DIN 3 - DIN 6.
- Press YES if the configured value of the BAUD RATE is correct, or press NO to change, then press YES.
- Press YES if the configured parity (PARITY) is correct (ODD, EVEN, NONE), or press NO to change, then press YES.
- Press YES if the configured value of the node address (NODE) is correct (from 1 to 247), or press NO to change, then press YES.
- Press YES if the configured status of termination 1 (TERMIN 1) is correct (ON/OFF), or press NO to change, then press YES.
- Press YES if the configured status of termination 2 (TERMIN 2) is correct (ON/OFF), or press NO to change, then press YES.
- Press YES if the configured MODE is correct (CH1, CH2, AUTO), or press NO to change, then press YES.

View Procedure

- Move the local selector to OFF and then press simultaneously OPEN and STOP. Select the language and then enter the password according to the instructions "entering the view mode". When the message of display is "VIEW MODE OK?" press YES. Press YES to select actuator setup menu, press NO to scroll the list of available routines and then press YES to select BUS CONTROL.
- Press YES to scroll the list of BUS CONTROL parameters.

9.1.2 Settings for ICON3000v2 Actuators

DIN 1 - DIN 6: by this routine it is possible to choose the condition associated to bits 8 - 13 of function code 02 (Read Discrete Inputs) and to the Holding Register address 3001. Here are the lists of the available conditions:

Status

- Open limit
- Close limit
- Position \geq xx %
- Position \leq xx %
- Closing
- Opening
- Motor running
- Blinker
- Mid-travel position
- Local selected
- Remote selected
- Local stop active
- ESD signal on
- Manual operation
- Interlock/PST
- Heater

Alarm

- Motor over-temperature
- Over-torque
- Over-torque in OP
- Over-torque in CL
- Valve jammed
- Warnings
- Valve jammed in OP
- Valve jammed in CL
- Low alkaline battery (if present)
- Mid travel alarm in CL/OP
- PST Failed
- Mains

The following settings are supplied as standard:

- DIN1: mid travel position
- DIN2: local stop active
- DIN3: motor over-temperature (motor thermostat alarm)
- DIN4: over-torque (Hi-Hi torque alarm)
- DIN5: valve jammed alarm
- DIN6: mid travel alarm in OP/CL

CH1 Baud: by this function it is possible to set the transmission speed used by the Channel 1. All devices on the same data line must have the same transmission speed.

CH1 Parity: this allows to choose the parity of the Channel 1 in the Modbus RTU messages (ODD, EVEN, NO PARITY).

CH1 Node: by this function it is possible to enter the node address of the Channel 1. Each device must have its address. Each address must be associated to one only device. The available address range is from 1 to 247.

CH2 Baud: by this function it is possible to set the transmission speed used by the Channel 2. All devices on the same data line must have the same transmission speed.

CH2 Parity: this allows to choose the parity of the Channel 2 in the Modbus RTU messages (ODD, EVEN, NO PARITY).

CH2 Node: by this function it is possible to enter the node address of the Channel 2. Each device must have its address. Each address must be associated to one only device. The available address range is from 1 to 247.

Termin. 1: by this routine the internal termination of Channel 1 can be connected to the BUS line (ON/OFF). Set "Termin. 1 = ON" only if the actuator is at the begin or at the end of the BUS line connected to the Channel 1.

Termin. 2: by this routine the internal termination of Channel 2 can be connected to the BUS line (ON/OFF). Set "Termin. 2 = ON" only if the actuator is at the begin or at the end of the BUS line connected to the Channel 2.

Mode: by this routine the Channel 1 and/or Channel 2 are enabled to work. Both channels can work simultaneously. If both channels are enabled and they are connected to the same BUS line, they must assume different addresses (CH1 Node ≠ CH2 Node).

Configuration Procedure:

- Move the local selector to OFF and then press simultaneously OPEN and STOP. Select the language and then enter the password according to the instructions "entering the set-up mode". When the message of display is "SETUP MODE OK?" press YES. Press YES to select actuator setup menu, press NO to scroll the list of available routines and then press YES to select BUS control.
- Press YES if the condition linked to DIN 1 is correct, or press NO to change, then press YES.
- Repeat the previous step for DIN 2, DIN 3 - DIN 6.
- Press YES if the configured value of the Baud Rate of CH1 (CH1 BAUD) is correct, or press NO to change, then press YES.
- Press YES if the configured value of the Parity of CH1 (CH1 PARITY) is correct (ODD, EVEN, NONE), or press NO to change, then press YES.
- Press YES if the configured value of the node address of CH1 (CH1 NODE) is correct (from 1 to 247) or press NO to change, then press YES.
- Press YES if the configured value of the Baud Rate of CH2 (CH2 BAUD) is correct, or press NO to change, then press YES.
- Press YES if the configured value of the Parity of CH2 (CH2 PARITY) is correct (ODD, EVEN, NONE), or press NO to change, then press YES.
- Press YES if the configured value of the node address of CH2 (CH2 NODE) is correct (from 1 to 247) or press NO to change, then press YES.
- Press YES if the configured status of Termination 1 (TERMIN. 1) is correct (ON/OFF), or press NO to change, then press YES.

- Press YES if the configured status of Termination 2 (TERMIN. 2) is correct (ON/OFF), or press NO to change, then press YES.
- Press YES if the configured MODE is correct (CH1, CH2, AUTO), or press NO to change, then press YES.

View Procedure

- Move the local selector to OFF and then press simultaneously OPEN and STOP. Select the language. When the message of display is “VIEW MODE OK?” press YES. Press YES to select actuator setup menu, press NO to scroll the list of available routines and then press YES to select BUS control.
- Press YES to scroll the list of BUS parameters.

9.2 Positioner Function

The function is available only on the modulating actuators. The value 0 of position request, received from BUS, corresponds to close request and the value 1000 corresponds to open request.

The ICON compares the present position % of the actuator with the position request % received from the BUS, and if the difference is greater than the dead band, the actuator is driven to reach the new requested position.

The following options can be configured via either bus or local operator interface:

- Dead band: configurable from 0.1% to 25.5% of the maximum position error (difference among position request % and present position %). The configured value should be great enough to avoid “hunting” effect of the actuator.
- Motion inhibit time: it allows to adjust the length of the delay time between two cycles of the motor. It can be configured from 1 to 255 s and allows to set the maximum number of start/hours of electrical motor.

Configuration Procedure

- Move the local selector to OFF and then press simultaneously OPEN and STOP. Select the language and then enter the password according to the instructions “entering the setup mode.” When the message of display is “SETUP MODE OK?” press YES. Press YES to select actuator setup menu, press NO to scroll the list of available routines and then press YES to select POSITIONER.
- Press YES if the configured value of the Dead Band is correct (from 0.1% to 25.5% of position error), or press NO to change, then press YES.
- Press YES if the configured value of the Motion Inhibit Time is correct (from 1 to 255 s), or press NO to change, then press YES.

View Procedure

- Move the local selector to OFF and then press simultaneously OPEN and STOP. Select the language. When the message of display is “VIEW MODE OK?” press YES. Press YES to select actuator setup menu, press NO to scroll the list of available routines and then press YES to select the routine (POSITIONER).
- Press YES to scroll the list of parameters.

9.3 Fail-Safe Function

This function is available only if requested on order. It allows configuring the action of the actuator in case of loss of the BUS signal. The action takes place only if the local selector is in REMOTE and if BUS is operating. When the BUS signal restores, also the actuator restores at its normal functioning. The fail safe function can be configured via either BUS or local operator interface.

The hardwired controls ESD and INTERLOCKS override the Fail-Safe action according to the following diagram.

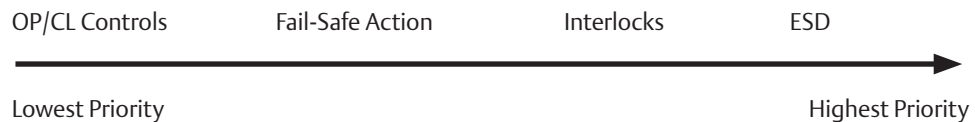

The following options can be configured:

- Fail-safe action: open, close, stay-put, go to position %, no action (OFF).
- Length of the delay time before than the fail-safe action takes place (length = 10 s + configured value).

Configuration Procedure

- Move the local selector to OFF and then press simultaneously OPEN and STOP. Select the language and then enter the password according to the instructions “entering the setup mode.” When the message of display is “SETUP MODE OK?” press YES. Press YES to select actuator setup menu, press NO to scroll the list of available routines and then press YES to select FAIL-SAFE.
- Press YES if the configured ACTION is correct (open, close, stay-put, go to position xx%, off), or press NO to change, then press YES.
- Press YES if the configured value of the DELAY is correct (from 0 to 255 s), or press NO to change, then press YES.

View Procedure

- Move the local selector to OFF and then press simultaneously OPEN and STOP. Select the language. When the message of display is “VIEW MODE OK?” press YES. Press YES to select actuator setup menu, press NO to scroll the list of available routines and then press YES to select the routine (FAIL-SAFE).
- Press YES to scroll the list of parameters.

9.4 Viewing Transmission Info

The following procedure allows to see the most significant info relevant to the BUS data transmission:
 Move the local selector to OFF or REMOTE and then press YES until the display shows NODE REPORT.
 Press NO to exit or press YES to scroll the list of transmission information.

9.5 BUS Signal Failure Indication

In case of loss of BUS signal, a warning is generated. It is signalled by the flashing of the relevant ALARM/WARNING LED and by indication on the local 2 lines/16 character display.

The figure below shows the list of routines available in the ICON 2000 view or setup menu.

Figure 12

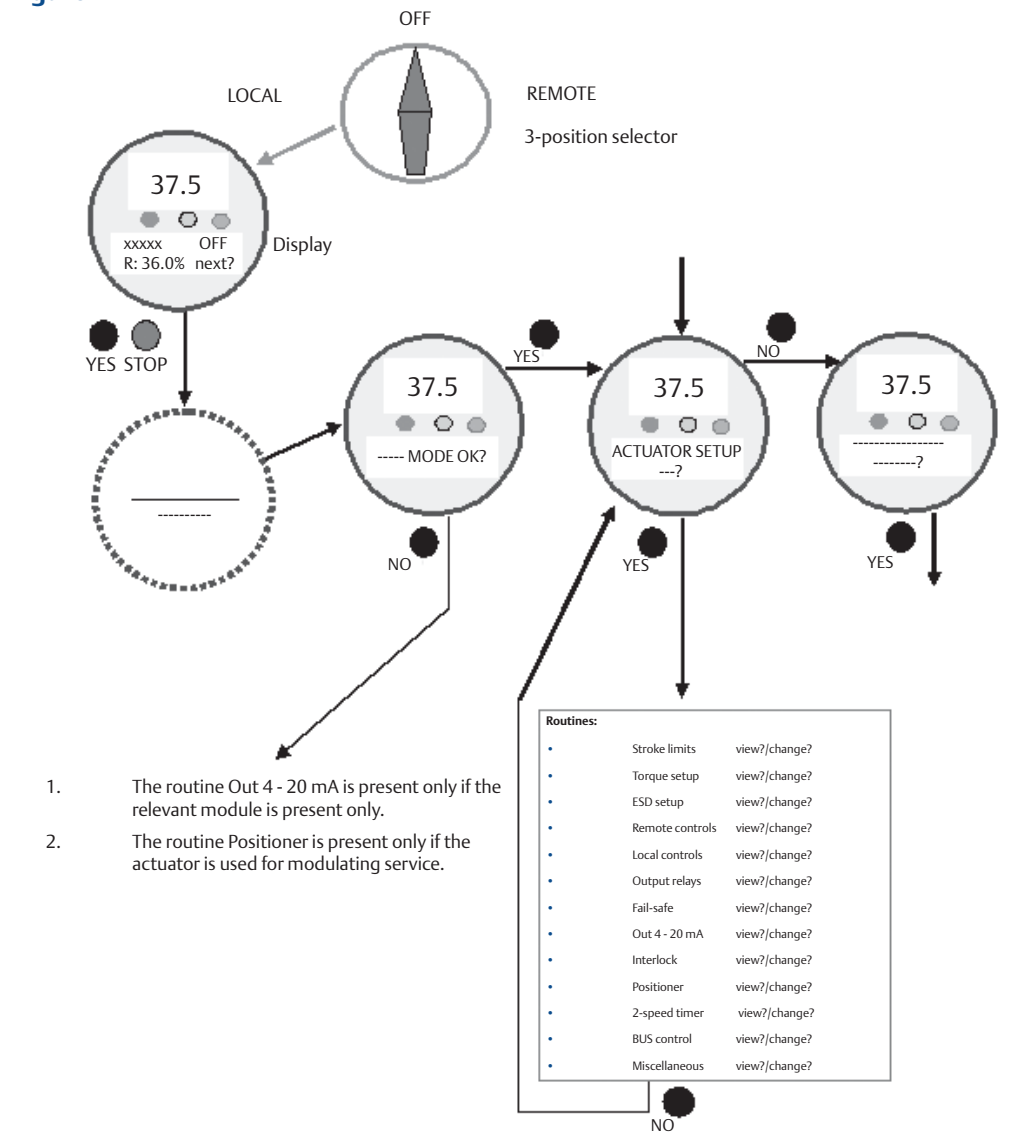

9.6 Actuator Terminal Board

Figure 13



9.6.1 Terminal Board Connections for ICON2000v4 and ICON3000

Legend:

Table 51.

EIA/TIA 485 Name	Modbus Specification	Terminal Board	CN3
B/B' CH1	D1 CH1	A1	L1B
A/A' CH1	D0 CH1	A2	L1A
C/C' CH1	Common CH1	A3	LS1
B/B' CH2	D1 CH2	A4	L1B
A/A' CH2	D0 CH2	A5	L2A
C/C' CH2	Common CH2	A6	LS2

Figure 14

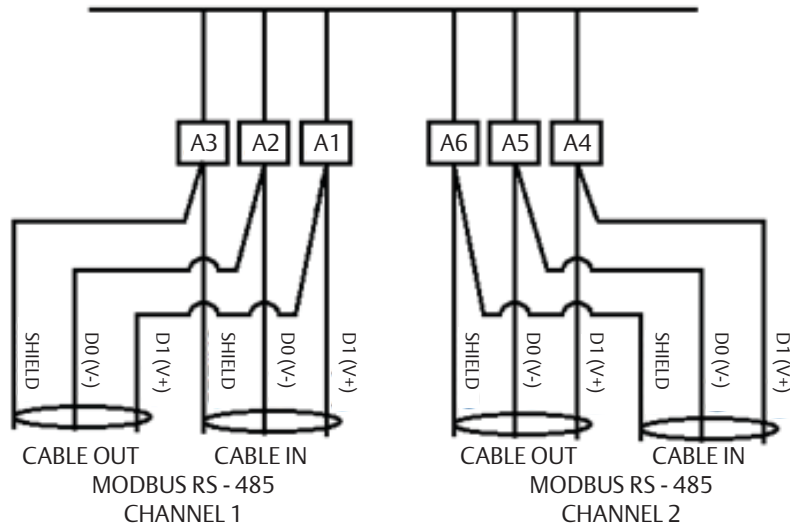

9.6.2 Terminal Board Connections for ICON3000v2

Legend:

Table 52.

EIA/TIA 485 Name	Modbus Specification	Terminal Board	CN2
B/B' CH1	D1 CH1	A1	L1P
A/A' CH1	D0 CH1	A2	L1N
C/C' CH1	Shield CH1	A3	-
B/B' CH2	D1 CH2	A4	L2P
A/A' CH2	D0 CH2	A5	L2N
C/C' CH2	Shield CH2	A6	-

Figure 15

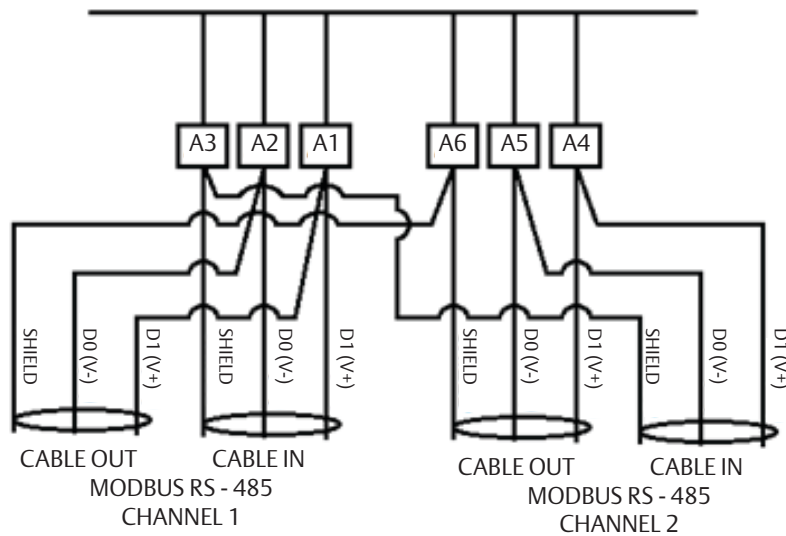

Section 10: Annex A

10.1 Replacement of 494MOD1000 with 494MOD1200 or 494MOD3200 (up to ICON3000)

NOTICE:

The instructions described in this section can be performed by qualified person only.

ICON3000 Modbus RTU module can be mounted only on base card revision 6.03 or subsequently. When a user needs to replace an older 494MOD1000 card with a new 494MOD1200 module, it's necessary to provide the following operations:

- Disconnect the 494MOD1000 card from the cable linked to the terminal board (see the Figure 16).

Figure 16

-
- Remove the 494MOD1000 interface card.
 - Cut the cable to have all the six wires available (1 shield and 2 signals for each channel).

Figure 17

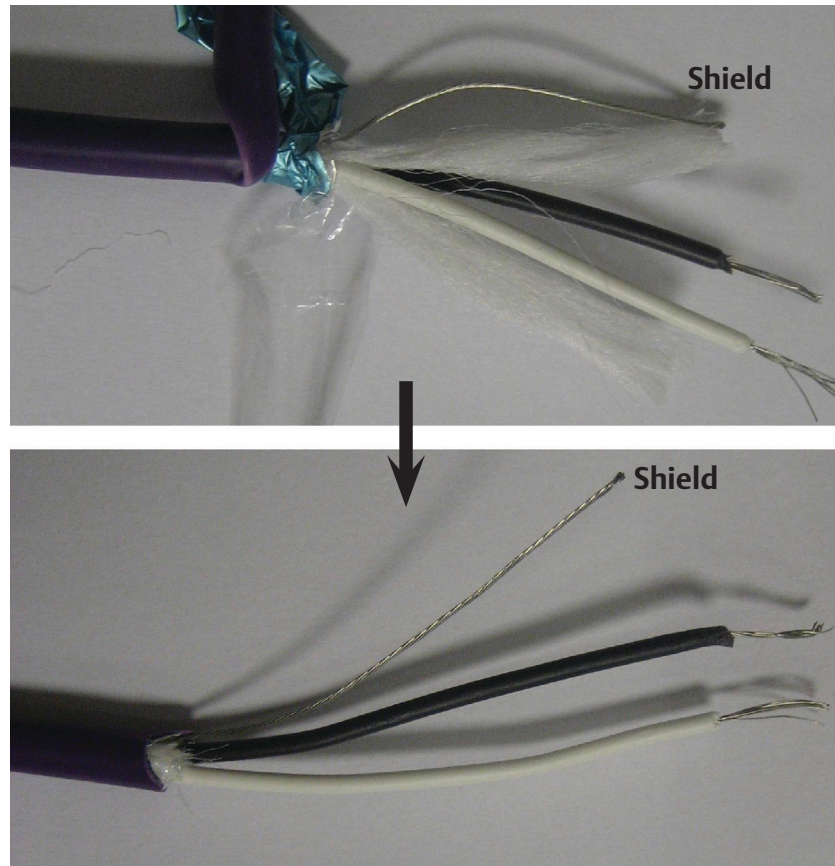

- Check through a tester, the link between the cable and the terminal board and connect every wire to the correspondent pin of CN3 connector (see the table in Section 9.6).

Figure 18

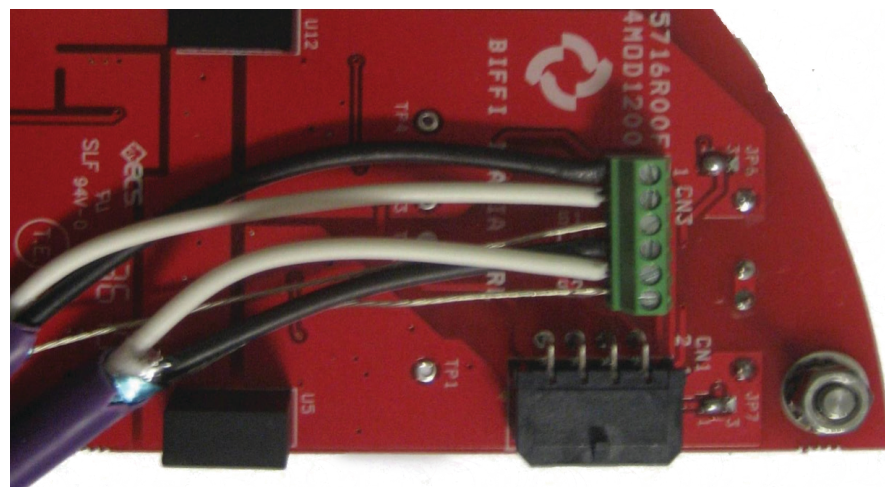

- Now connect the 494MOD1200 interface card to the actuator logic card.

Figure 19

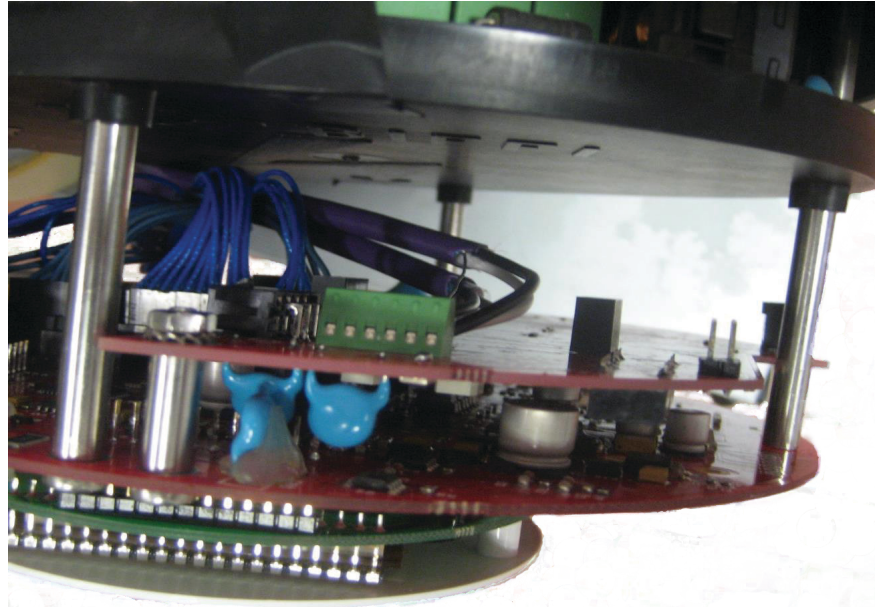

10.2 Replacement of 494MOD*** with Modbus RTU Interface (ICON3000v2)

NOTICE:

The instructions described in this paragraph can be performed by qualified person only.

When a user needs to replace an older 494MOD*** card with a new Modbus RTU Interface, it's necessary to provide the following operations:

- Power off the actuator.
- Disconnect the 494MOD*** card from the cable linked to the terminal board (see Figures 20 and 21).

Figure 20

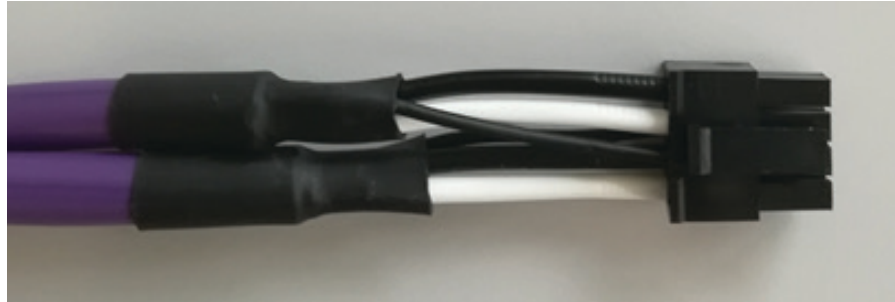

Figure 21 494MOD1200 or 494MOD3200 (ICON2000v4 and ICON3000)

-
- Disconnect all other logic card cables.
 - Remove the logic board and the 494MOD**** interface card.
 - Replace the former logic board with the logic board of the ICON3000v2/XTE3000 actuators families.
 - Cut the bus cable to have all the six wires available (1 shield and 2 signals for each channel).

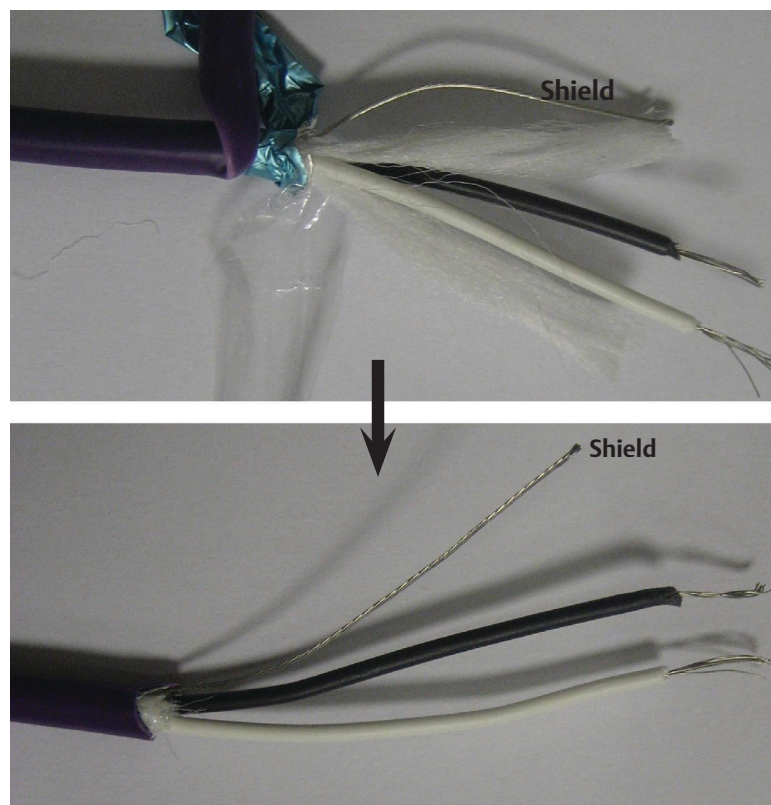
Figure 22

-
- Check, through a tester, the link between the cable and the terminal board and connect every wire to the correspondent pin of CN2 and CN3 connectors (see tables 51 and 52).

Figure 23

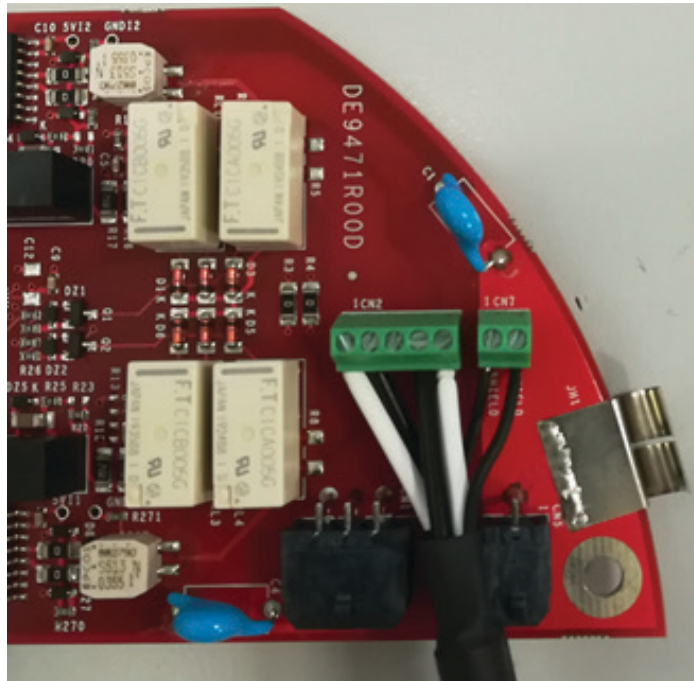

- Connect the Modbus RTU Interface to the actuator logic card.

Figure 24

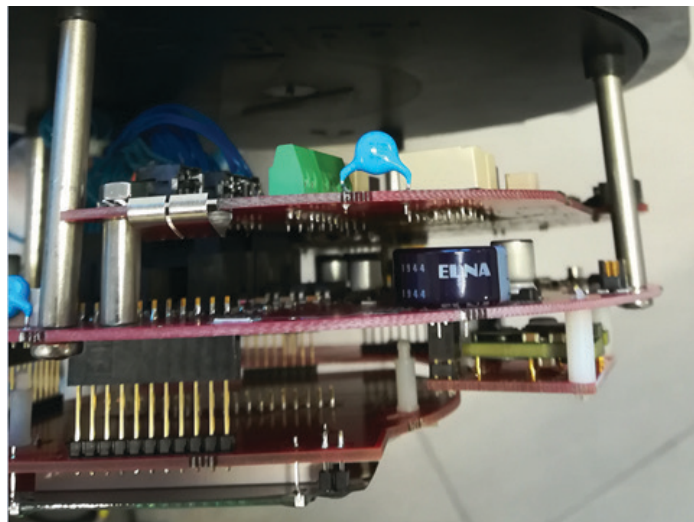

Section 11: Annex B - Writing Modbus I/O Data

On ICON3000v2 has been introduced a new security level: to modify the writable Modbus Data (Coils and Holding Registers), it's necessary to correctly set the user and the password in the corresponding Holding Registers (addresses 3482, 3483, 3484, 3485 and 3486).

4 User levels are available:

- **OBSERVER (lower level):** able to read only all the Modbus data.
- **USER:** able to read all the Modbus data and to modify the Coils and the Holding Registers that require OBSERVER or USER permissions.
- **SERVICE:** able to read all the Modbus data and to modify most the Coils and the Holding Registers that require OBSERVER, USER or SERVICE permissions.
- **MANUFACTURER (higher level):** able to read all the Modbus data and to modify all the Coils and the Holding Registers.

The "User Level Logged" (HR address 3480) on the actuator indicates the permissions currently granted: its value is the result of the combination of the "User Level" (HR address 3482) and the "User Password" (HR addresses 3483, 3484, 3485, 3486).

At the power up, the Modbus RTU Interface login automatically as "USER" user level.

If the Master tries to modify a Coil/Register without having the minimum required permissions, no exception errors are returned but the value is discarded.

How to login as OBSERVER:

- Set "User Level" HR (address 3482) to 0x0000.
- Set "User Password (1/4)" HR (address 3483) to any value.
- Set "User Password (2/4)" HR (address 3484) to any value.
- Set "User Password (3/4)" HR (address 3485) to any value.
- Set "User Password (4/4)" HR (address 3486) to any value.

How to login as USER

- Set "User Level" HR (address 3482) to 0x0001.
- Please, contact the manufacturer for "User Password" values.

How to login as SERVICE or MANUFACTURER

- These user levels are reserved for Service Technicians and manufacturer.

Section 12: Annex C - PST Command Requirements

This addendum describes the configuration settings required to perform the PST command.

PST Command is performed by the actuator only if:

- EFS Input Mode (HR Addresses 3028 or 3610) = 0 → PST-EFS
- Interlock Mode (HR Addresses 3027 or 3920) = 1 → Advanced

If at least one of the above parameters is configured differently, the PST command is ignored and not executed.

See actuator IOM for additional details about the PST command.

Biffi Italia s.r.l.
Strada Biffi 165
29017 Fiorenzuola d'Arda (PC)
Italy
T +39 0523 944 411

For complete list of sales and manufacturing sites, please visit
www.biffi.it or contact us at biffi_italia@biffi.it

VCIOM-16345-EN (PC-15081) ©2022 Biffi. All rights reserved.

The contents of this publication are presented for information purposes only, and while every effort has been made to ensure their accuracy, they are not to be construed as warranties or guarantees, express or implied, regarding the products or services described herein or their use or applicability. All sales are governed by our terms and conditions, which are available on request. We reserve the right to modify or improve the designs or specifications of our products at any time without notice.

