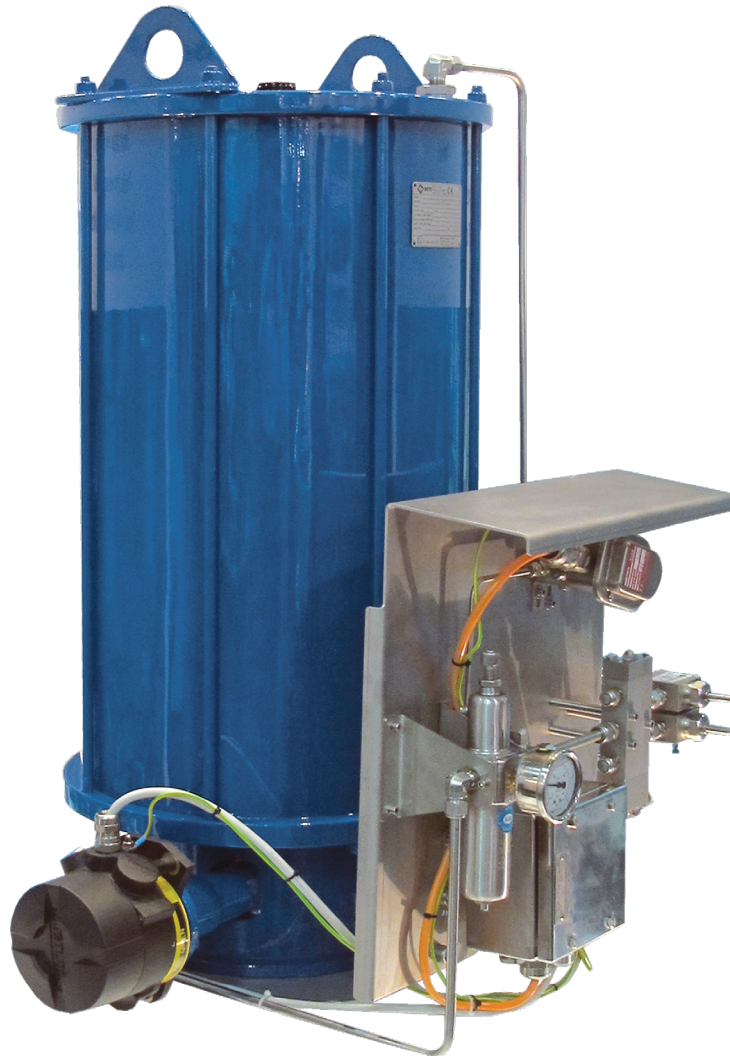


Biffi TPS Series - Quarter-Turn Pneumatic

Compact Pneumatic Actuator – Single-Acting Actuator



Before carrying out any operation with the actuator or any maintenance intervention, all the instructions, procedures and warnings described in this Installation, Operation and Maintenance Manual (IOM) must be read and understood.

Furthermore, please refer to the confirmation documentation for further information depending on the configuration of the pneumatic actuator referred to in the present IOM.

- TO BE KEPT FOR FUTURE REFERENCE -

Table of Contents

Section 1: Introduction

1.1	Purpose of This Manual.....	1
1.2	Who Should Use This Manual.....	1
1.3	Safe Keeping of This Manual.....	2
1.4	Supplements and Revisions.....	2
1.5	Reading Through This Manual.....	2
1.6	Symbols Used in the Text.....	3

Section 2: General Information

2.1	Identification Data of the Manufacturer.....	4
2.2	IOM Identification Data.....	4
2.3	Requesting Technical Assistance.....	5
2.4	Spare Parts Ordering.....	5
2.5	Intended Use.....	6
2.6	Misuses.....	6
2.7	Limitation of Use.....	7
2.8	General Safety Provisions.....	8
2.9	Limitation of Liability.....	8
2.10	Warranty.....	8
2.11	Regulatory Reference Framework.....	9
2.12	Tear Down and Disposal.....	9

Section 3: Technical Description

3.1	Fields of Application.....	10
3.2	Identification Data of the Actuator.....	10
3.3	General Safety Provisions.....	13
3.4	Safety Provisions for Installation in Hazardous Areas.....	14
3.5	Actuator Applications.....	15
3.6	General Description.....	15
3.7	Main Features.....	16
3.8	Options and Configurations.....	18
3.9	Accessories.....	18
3.10	Reading and Understanding the Product ID Code.....	19
3.11	Main Components and Materials.....	20
3.11.1	TPS 0.A Actuator.....	20
3.11.2	TPS 0.1/0.3/0.9/1.5/3 Actuators.....	21
3.11.3	TPS 6 Actuator.....	22
3.11.4	TPS 14/18/32 Actuators.....	23
3.12	Technical Data.....	24
3.12.1	General Data.....	24
3.12.2	Overall Dimensions, Weights and Estimated Center of Gravity Position.....	25
3.13	Valve Coupling Interface (Top Mounting).....	27
3.14	Connecting the Stem Valve.....	32
3.15	Pneumatic Interfaces (TPS 0.A/0.1/0.3/0.9/1.5/3).....	33

3.16	Pneumatic Interfaces (TPS 6)	34
3.17	Pneumatic Interfaces (TPS 14/18/32).....	35
3.18	Other Interfaces, Devices and Accessories.....	37
3.19	Minimum Requirements for Installing Control, Signalling and Diagnostic Devices on Board the Actuator	39
Section 4: Health and Safety Provisions		
4.1	Introduction	40
4.2	Duties of the Safety Officer.....	41
4.3	Duties of the Staff Interacting with the Actuator.....	41
4.4	Residual Risks	42
4.5	Information on Personal Protective Equipment (PPE).....	43
Section 5: Transport and Handling		
5.1	Transport of the Actuator.....	44
5.1.1	General Information	44
5.2	Lifting the Actuator.....	45
5.2.1	Lifting Points.....	45
5.2.2	Codes of Practice for Lifting Operations.....	47
5.3	Actuator Handling.....	48
5.3.1	General Handling Provisions	48
Section 6: Receipt and Installation of Actuator		
6.1	Receipt and Inspection.....	49
6.2	Storage.....	49
6.3	Customer Duties	50
6.4	Assembly Procedures.....	50
6.4.1	Assembly	51
6.4.2	Pneumatic Connections.....	54
6.4.3	Electrical Connections (If Foreseen).....	55
Section 7: Commissioning and Adjustments		
7.1	Inspections Prior to Commissioning	56
7.2	Calibrating the Angular Stroke.....	57
Section 8: Biffi Limit Switch Box (If Fitted)		
8.1	Calibration of Biffi Limit Switches (If Fitted).....	62
8.1.1	Limit Switch Calibration Procedure	63
8.1.2	Indicator Reset Procedure	65
Section 9: Routine Maintenance		
9.1	General Information.....	66
9.2	Monitoring and Visual Inspection Activities.....	67
9.3	Monitoring and Visual Inspection Activities for SIL Certification	67

Section 10: Supplementary Maintenance

10.1	General Information About Supplementary Maintenance.....	69
10.2	Technical Guidelines for Replacing the Pneumatic Cylinder Seals	71
10.2.1	General Description.....	71
10.2.2	Partial or Total Seal Replacement.....	76
10.2.3	Disassembling the Pneumatic Cylinder.....	78
10.2.4	Replacing the Seals.....	82
10.2.5	Assembling the Pneumatic Cylinder	82
10.3	Information Necessary for Seal Replacement.....	85
10.4	Lubrication	87

Section 11: Spare Parts

11.1	Pneumatic Cylinder Seals (Material: NBR).....	89
11.2	Pneumatic Cylinder Seals (Fluorosilicone material)	90

Section 12: Troubleshooting

	Troubleshooting.....	91
--	----------------------	----

Section 13: Dismantling and Tear Down

	Dismantling and Tear Down.....	92
--	--------------------------------	----

This page is intentionally left blank

NOTICE

Biffi Italia s.r.l. has taken every care in collecting and verifying the documentation used in drafting the present Installation, Operation and Maintenance Manual. Nevertheless, Biffi Italia s.r.l. does not provide any guarantees with regard to this IOM Manual. Biffi Italia s.r.l. shall not be held responsible for any mistake or inaccuracy contained herein, or for any damage whether accidental or arising from the use of this manual.

Biffi Italia s.r.l. is the owner of intellectual property rights with regard to the content hereof, which can be subject to subsequent modifications without prior notice.

NOTICE

The information contained in this IOM refers only to the actuator and not to any of the accessories (such as: pneumatic control panel, device indicating the open/closed status of the valve, etc.) for which reference must be made to the relevant documentation.

Section 1: Introduction

NOTICE

Biffi Italia s.r.l. owns all intellectual property rights over the content of this manual. Any reproduction thereof, in whole or in part, is prohibited without the prior written permission of Biffi Italia s.r.l. Biffi Italia s.r.l. reserves the right to make changes without notice with respect to the content of this document.

1.1 Purpose of This Manual

The purpose of this manual is to specify the expected use of the actuator as intended in the design and to provide the necessary instructions as regards transport, handling, installation, adjustment and use, staff training, accident prevention, maintenance and spare parts ordering. A description of the main technical features of the actuator is also included.

However, in terms of conditions of use, risk assessment and accident prevention, the content of the manual cannot be a substitute for the users' experience.

1.2 Who Should Use This Manual

- Safety Supervisor of the plant where the actuator is being used.
- Personnel in charge of lifting and transport.
- Personnel in charge of assembly, use and adjustment.
- Personnel in charge of maintenance and disposal.

1.3 Safe Keeping of This Manual

For a proper safekeeping, please keep the manual in a protected and dry place, sheltered from dust and sunbeams. A copy of the manual must always be available to hand for both operator and maintenance technician.

Do not remove, add or modify any part of the manual: only the manufacturer of the actuator is entitled to make any changes.

NOTICE

This manual must be kept at the actuator location at all times and for the entire life cycle, even in case of conveyance or sale to third parties.

1.4 Supplements and Revisions

This manual reflects the state-of-the-art technology existing when the machine was marketed and cannot be considered as inadequate due to subsequent revisions made on the basis of new knowledge.

The manufacturer reserves the right to make changes to the production and relevant documentation, without being bound to make changes to the previous production and documentation, except in those cases where the health and safety of persons and property is concerned.

1.5 Reading Through This Manual

This IOM consists of sections, each relating to a specific topic. The sections, figures and tables are numbered in chronological order. Warnings and pieces of information have each been inserted within the most appropriate section and are not repeated elsewhere. For this reason, the manual must be read first entirely and in sequence, from beginning to end, and all such information must be understood and kept in mind. Afterwards, only the required sections can be referred to.

1.6 Symbols Used in the Text

The graphical symbols used in this manual to point out precautions or warnings that must be observed, are listed below:

NOTICE

It is absolutely MANDATORY to carry out the actions indicated by this sign.

⚠ CAUTION

It is absolutely PROHIBITED to carry out the actions indicated by this sign.

⚠ WARNING

It indicates an action or behavior likely to cause damage to property or persons.

Hereunder is a list of the graphic symbols used in this manual in order to make reading easier, and understanding of certain significant parts of the text more immediate. Each symbol (ISO 7000) is identified by its related image, code number
General Information



0421 EXAMINE – CHECK



0717 CALL FOR MAINTENANCE



0981 DATA CARRIER

Section 2: General Information

NOTICE

The manual is an integral part of the machine. It should be carefully read before carrying out any operation and it should be kept for future references.

2.1 Identification Data of the Manufacturer

Biffi Italia s.r.l.

Phone: +39 0523 94.44.11
Fax: +39 0523 94.18.85
Email: biffi_italia@biffi.it
Website: www.biffi.it

Strada Biffi n. 165
29017 Fiorenzuola d'Arda (PC)
Italy

Member Company under the management and coordination of
Emerson Electric Co. (USA)

Cap. Soc. € 1.820.000 i. v. – Registro Imprese di Piacenza/Cod. Fisc./P.
IVA n. 01018580330

R.E.A. di Piacenza n. 121628 - Meccanografico PC 00279 - Authorized Economic
Operator IT AEOF 11 0383

2.2 IOM Identification Data

The identification code, the revision number and the edition of this manual are featured on the header of each page: these data must be specified when purchasing additional copies of the manual.

2.3 Requesting Technical Assistance

For any information regarding:

- Use
- Maintenance
- Installation

You may contact Biffi Italia s.r.l. After Sales Service:

Biffi Italia s.r.l.
- After Sales Service -

Strada Biffi 165 – 29017 Fiorenzuola d'Arda (PC), Italy
Phone: +39 0523 94 45 23
Fax: +39 0523 94 18 85
E-mail: biffiservice@emerson.com

NOTE:

Any inquiry or request for assistance submitted to the After Sales Service must indicate the data featured on the rating plate of the machine.

2.4 Spare Parts Ordering

The parts subject to normal wear and tear require periodic replacement. Whenever ordering spare parts, make sure they can be clearly identified by submitting the relevant info, such as code number featured in the diagrams, ID data featured on the physical label, any reference code mentioned in this IOM, etc.).

The request must be addressed to:

Biffi Italia s.r.l.
- Spare parts service -

Strada Biffi 165 – 29017 Fiorenzuola d'Arda (PC), Italy
Phone: +39 0523 94 45 23
Fax: +39 0523 94 18 85
E-mail: biffiservice@emerson.com

NOTICE

Always use genuine spare parts to preserve the safety conditions provided by the manufacturer.

2.5 Intended Use

The actuator is designed to be used by adequately instructed and trained technical personnel for professional applications only.

The machine must only be used as intended by the manufacturer, namely in accordance with the definition given under the heading "Actuator applications", with the relevant details regarding performance, features and restrictions, listed in Section 3: Technical Description, and with the procedures for use, adjustment, maintenance and cleaning described in this manual.

In particular:

- The actuator must be installed properly;
- The characteristics regarding the electrical power supply, pneumatic supply, hydraulic supply, etc.:
 - Must correspond to the values indicated on the actuator rating plate;
 - Must have a variability that does not exceed the contractual limit values or those indicated on the actuator rating plate.
- The environmental operating conditions must always be observed;
- The specified performance values must always be observed, namely: pressure, temperature, load conditions, etc.;
- The procedures described in this manual as regards use and maintenance must always be observed;
- All the provisions concerning the safety of persons and property must be strictly observed.

Any exception to what so far stated must be decided upon during the contractual stage. Should that not be the case, the purchaser shall be charged with both civil and criminal liability in relation to any improper use whatsoever of the actuator.

Any other use not specifically indicated must be considered improper.

2.6 Misuses

Any use of the actuator not described in this manual must be regarded as "not intended" by the manufacturer.

When installed in the plant together with all the accessories specified in the order acknowledgement, the actuator cannot be operated if the guards provided by the manufacturer are not fixed in place, and/or if the safety equipment is not assembled, not connected, not adjusted, deliberately excluded or in any way ineffective.

2.7 Limitation of Use

Please refer to the environmental conditions where the actuator is employed. In addition to the information given in Section 3.12: Technical Data, the provisions listed below must also be observed:

CAUTION

- **ATMOSPHERE AT RISK OF FIRE**
It is FORBIDDEN to use TPS series actuators in environments at risk of fire and not equipped with suitable systems for the prevention and extinguishing of fires.

NOTE:

The TPS Series pneumatic actuators can be installed in areas at risk of fire exclusively if they are suitably protected (for example, by means of flameproof covering or of materials with specific fire resisting characteristics). Please refer to the documentation relating to the order confirmation for the installation instructions concerning this problem.

- **EXPLOSIVE ATMOSPHERE**
It is FORBIDDEN to use TPS series actuators beyond the limits indicated on the rating plate as regards ATEX certification.

NOTE:

TPS series pneumatic actuators can be used in explosive atmosphere with the following classification of zones: zone 1/21.

- **ENVIRONMENTAL PRESSURE**
It is FORBIDDEN to use TPS series actuators in "underwater" environments

NOTE:

TPS series actuators comply with standard EN 60529:1991 + A1:2000 with reference to IP66M and IP67M degrees of protection. Consistently with the test conditions provided by the Standard, TPS series actuators can be installed partially or totally immersed, but cannot be installed in underwater environments where the actuator can be externally exposed to the action of hydrostatic pressure.

- **CORROSIVE ATMOSPHERE**
It is FORBIDDEN to use TPS series actuators in environments containing acids, except for the information below.

NOTE:

The quality of the products used and the varnishing method offer a C5I/C5M protection classification, pursuant to Standard UNI EN ISO 12944, in that way making the actuator suitable for industrial/maritime/off-shore applications.

NOTE:

For any installation instructions differing from those set out in the present IOM, kindly refer to the documentation relative to the order acknowledgement.

WARNING

Non-compliance with prohibition notices may cause harm to persons and damage to property.

2.8 General Safety Provisions

The general provisions as regards health, safety and accident prevention are described in detail in Section 4: Health and Safety Provisions.

They refer to all the stages of actuator use, from installation to operation and from transport to disposal. The general safety provisions are not repeated in any of the other sections; therefore, before carrying out any operations, make sure you fully understand them.

2.9 Limitation of Liability

Biffi Italia s.r.l. declines all liability arising from the misuse or not reasonably foreseeable use of the actuator; use of non-genuine spare parts and from any modification or tampering whatsoever.

The safety supervisor is responsible for the thorough and scrupulous enforcement of the safety provisions. The safety supervisor must also ascertain that the personnel entrusted with the use of the machine hold the qualifications to carry out the required task, are knowledgeable about the instructions described in this manual and about the general safety provisions applicable to the actuator.

WARNING

Failure to observe the safety rules may cause personal injury and may damage actuator components.

2.10 Warranty

Biffi Italia s.r.l. guarantees that all the items produced are free of defects in workmanship and manufacturing materials and meet relevant current specifications, provided they are installed, used and serviced according to the instructions contained in the present manual. The warranty can last either one year from the date of installation by the initial user of the product, or eighteen months from the date of shipment to the initial user, depending on which event occurs first. All detailed warranty conditions are specified in the documentation forwarded together with the product.

The warranty does not cover special products or components not covered by warranty in their turn by subcontractors, or materials that were used or installed inappropriately, which were modified or repaired by unauthorized staff.

In the event that a fault condition is caused by improper installation, maintenance or use, or by irregular working conditions, the repairs will be charged according to applicable fees.

The warranty and Biffi Italia s.r.l. liability shall lapse in the event that any modification or tampering whatsoever be performed on the actuator.

2.11 Regulatory Reference Framework

Biffi Italia s.r.l. actuators are designed, manufactured and controlled according to the Quality Control System in compliance with EN ISO 9001 International Standard.

Biffi Italia s.r.l. actuators, subject matter of the present document, are designed, manufactured and tested in compliance with the requirements and provisions laid down in the directives and standards listed below:

IMPLEMENTED DIRECTIVES

2006/42/EC	Machinery Directive
2014/68/EU	Directive for pressure PED equipment
2014/35/EU	"Low Voltage" Directive
2014/30/EU	"Electromagnetic Compatibility" Directive
2014/34/EU	Directive and safety instructions intended for use in potentially explosive atmospheres

HARMONIZED STANDARDS

UNI EN ISO 12100: 2010	Safety of machinery - General principles for design - Risk assessment and risk reduction
------------------------	--

2.12 Tear Down and Disposal

At the end of its lifespan, the actuator must be dismantled and the various parts and components must be disposed of accordingly.

NOTICE

During this stage, strictly comply with all the relative regulations in force in the country where the actuator was in use.

The actuator CE Mark plate must be totally destroyed.



For further information:
Section 13: Dismantling and Tear Down

Section 3: Technical Description

3.1 Fields of Application

The subject matter of the present manual are the single acting actuators of the Quarter-Turn Pneumatic (TPS) series and their various configurations.




The present manual applies only to the actuator intended as a mechanical device that delivers an operating torque for the 90° rotation of a quarter-turn valve, which is moved by a pneumatic cylinder or by the elastic energy of the spring.

The present manual does not apply to any accessories installed on the actuator, for which you have to refer to the relevant annexed documentation specified on the order acknowledgement (of which this manual is an integral part).

3.2 Identification Data of the Actuator

The main identification data of the order acknowledgement are featured on the plate affixed to the actuator and shown in Figure 1 below.

Figure 1. Rating Plate

		Manufacturer: BIFFI ITALIA Strada Biffi, 165 29017 Fiorenzuola D'ARDA (PC) - ITALY			
Order _____					
Model _____					
ACTUATOR	S/N _____		MM/YYYY _____		
	TAG N° _____		ND _____		
Supply Press. Range _____				MOP _____	
Amb. Temp. _____					
CYLINDER	Fl. Type _____		Fl. Group _____		PED Cat. _____
	TS _____		Test Date _____		_____
PS _____		PT _____		Cyl. Weight _____	
		Ref: _____		WARNING: Potential Electrostatic Charging Hazard See Instructions	



NOTICE

The purchaser must make sure the plate is never removed from the actuator and the featured data are always clearly legible.

CAUTION

It is forbidden to modify the information and the marks without previous written authorization by Biffi Italia s.r.l.

The rating plate shown in Figure 1 complies with the directives listed in Section 2.11 and features clearly legible and ineffaceable data, namely:

- In the upper part:
 - Name and address of the manufacturer.
 - CE Mark pursuant to Directive 97/23/EC (until 18/07/2016) or 2014/68/EU (from 19/07/2016) and the identification number of the notified body. Optional featuring: the identification number of the notified body is present if the product is marketed in countries where Directive 97/23/CE (until 18/07/2016) or 2014/68/EU (from 19/07/2016) is a mandatory requirement or on the purchaser's demand when the above-mentioned Directive is not applicable.
- "ORDER" field – Customer order number.
- "CONFIRM" field – Order acknowledgement number.
- "MODEL" field – Reference number of the actuator subject matter of the order.
NOTE: The product identification code can be easily interpreted by referring to Section 3.10, where the meaning of the various fields is explained in detail.
- "S/N" field – Serial number of the production list associated to the machine.
NOTE: the actuator is one of the elements of the entire supply (Section 3.1), which includes also the accessories, control panel and sundry items.
- "MANUFACTURE YEAR" field – year of manufacture.
- "FLUID" field – type of pressurized fluid used inside the pneumatic cylinder.
- "ALLOWABLE TEMPERATURE RANGE" field – external environment temperature range in which the actuator can be used.
- "MAXIMUM ALLOWABLE PRESSURE" field – maximum allowable pressure of fluid inside the pneumatic cylinder.
- "SUPPLY PRESSURE" field – reference pressure range as regards the operating conditions specified in the order acknowledgement.
- "VALVE TAG" field – identification data of the valve on which the actuator has to be installed.
- "DN" field – nominal dimension of the line on which the valve is installed (optional feature).
- " " field – line left empty for any particular remarks regarding the order acknowledgement.
- In the lower part:
 - The mark and data regarding the actuator performance and application limits pursuant to Directive 94/9/EC (ATEX):
 -   II 2 GD c 135 °C (T4)

NOTE:

The meaning of the marking pursuant to Directive 94/9/EC is given below:

II	=	Group II (surface)
2	=	Category 2 (zone 1)
G	=	Explosive atmosphere with the presence of gases, vapors or mists
D	=	Explosive atmosphere with the presence of dusts
c	=	Constructional safety according to EN 13463-5
135 °C (T4)	=	Maximum surface temperature/ temperature classification
-40 to +100 °C	=	Ambient temperature range (refers to minimum allowable temperature according to the project configuration – refer to Section 3.12.1)

Table 1. Correspondence Between Hazardous Areas, Substances and Categories Pursuant to Directive 94/9/EC

Substance	Hazardous Area	Category
Gases, vapors or mists	Zone 0	1G
Gases, vapors or mists	Zone 1	2G or 1G
Gases, vapors or mists	Zone 2	3G, 2G or 1G
Dusts	Zone 20	1D
Dusts	Zone 21	2D or 1D
Dusts	Zone 22	3D, 2D or 1D

NOTE:

This indication refers to the performance levels resulting from qualification tests performed by competent authority or certification laboratory.

3.3 General Safety Provisions

The list below contains the general safety provisions that must be strictly observed:

⚠ WARNING

Uses different from or additional to those provided in this IOM are not permitted and Biffi Italia s.r.l. will not be liable for any damages arising from non-intended uses.

⚠ WARNING

All maintenance interventions must be performed according to the instructions contained in the IOM: no mechanical modification is permitted without prior written authorization from Biffi Italia s.r.l.

⚠ WARNING

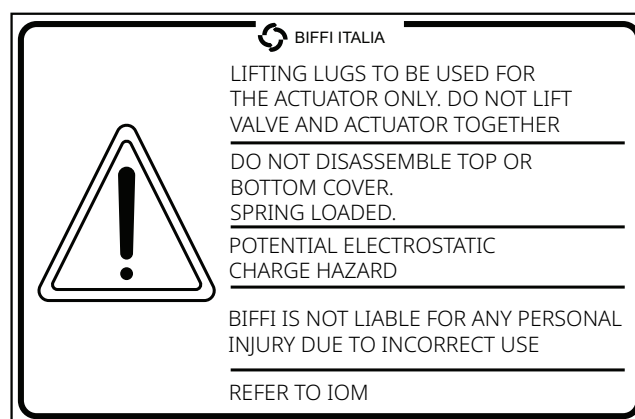
Unauthorized replacements or using non-genuine spare parts will undermine the actuator's safety; all spare parts must be requested from Biffi Italia s.r.l.

⚠ WARNING

All electrical equipment/components must not be opened when still live. The actuator must not be opened when still pressurized.

The adhesive plate shown in Figure 2, featuring information on the proper use of the actuator and on safety provisions, is affixed to all the TPS series models.

Figure 2. Identification Plate



⚠ WARNING

To ensure its proper application (Section 3.5), the product is provided with a spring inside, which is constantly under compression.

- Do not disassemble the product.
- In those cases where the product needs to be dismantled, strictly comply with the provisions specified in this manual.

3.4 Safety Provisions for Installation in Hazardous Areas

WARNING

Before proceeding with the installation procedures, carefully read the indications specified in the IOM.

The actuators can be provided with electrical equipment or components which, pursuant to Directive ATEX, are subject to separate certification, and mechanical components that are in compliance with the same Directive.

All the electrical and mechanical equipment and components must be suitable for use in zones classified with the presence of gas belonging to group II and or with the presence of combustible dusts. The temperature classification and/or the maximum temperature regarding components must meet the temperature limits provided for the different versions of the actuator.

TPS series pneumatic actuators must be installed and serviced according to the installation and servicing regulations for places classified against the risk of explosion due to the presence of gases/dusts or for mines (for instance: EN 60079-14, EN 60079-17, or other national regulations/standards).

WARNING

The TP series pneumatic actuator must be adequately connected to the ground via the anti-loosening and anti-rotation device.

The electric resistance measured between the various metal parts of the actuator and the reference point must be checked at the time of the first installation and during the scheduled inspections.

WARNING

The actuator must not be isolated from the ground; periodically check the actuator grounding to ensure its efficiency through time.

As regards the actuator earth connection, refer to Section 3.18.

In case of combustible dusts, clean regularly to prevent the formation of layers. All maintenance operations must be performed according to the indications provided in the IOM.

Depending on the type of application and substances, the user must periodically check the conditions below:

- Incrustations, dirt, wear and smooth operation of the actuator;
- Vibrations and/or strange noises. In that case, stop the actuator, identify the causes and call the manufacturer.

However, residual risks can arise while the TPS series actuator is running normally if:

- The provided maintenance schedule is not observed;
- The actuator is not used according to the design specifications.

3.5 Actuator Applications

The actuator identified as Quarter-Turn Pneumatic TPS Series is designed and produced to open/close quarter-turn valves, such as ball, butterfly or plug valves in both on-off and modulating service.

The kinematic mechanism is driven by a single-acting pneumatic cylinder with spring-return which, in its different configurations, allows the spring to be opened/closed. In these configurations, a clockwise/counterclockwise - respectively - rotation of the valve stem is determined by the action of the spring when no pressurized air is present inside the pneumatic cylinder.

3.6 General Description

NOTE:

The technical description is deliberately simplified. The purpose is to provide useful pieces of information for staff assigned to installation and maintenance to work under safe conditions, such as: operating principle, layout, component identification, different configurations and options.

Our TPS Series Quarter-Turn Pneumatic actuators are provided with a “helical spline” kinematic mechanism that converts the linear movement generated by a pneumatic cylinder (or by a spring) into a 90° rotation. When the cylinder is being supplied, the pressure applied to the piston exerts a thrust and subsequent downward movement. The rotation of the rotary element (output drive) and the transmission of torque to the valve stem are obtained by interaction and contact between the components of the kinematic mechanism.

The relevant reaction torque is absorbed by the structure of the actuator.

The winding direction of the helical splines (left or right hand) determines the counterclockwise or clockwise rotation of the output drive whenever a downward movement of the translating elements occurs.

The different winding direction of the helical spline distinguishes the two different configurations: “fail to close” and “fail to open” (Table 3: Configuration Definitions).

The helical spline is designed to ensure:

- An angular rotation equal to 90° (the strokes needed to ensure such rotation depend on the size of the kinematic mechanism);
- The possibility to adjust, by means of specific stroke limits (called stoppers), the initial angular position as well as the final angular position of the output drive within a ±5° tolerance range.

In that way, not only is the functional rotation of the valve always guaranteed, but also any misalignment between the valve stem and the output drive can be adjusted within a ±5° error range.

The actuator is provided with various types of interfaces, namely:

- To couple the actuator to the valve (refer to Section 3.13)
- To connect the output drive to the valve stem (refer to Section 3.14)

NOTE:

Connection to the valve stem is done by means of a bush insert or a sleeve machined internally (by Biffi Italia s.r.l. or by the customer) to fit the geometry of the valve stem.

- To supply the pneumatic cylinder (refer to Section 3.15)

NOTE:

The cylinder is provided also with the interface for the pneumatic supply of the cylinder lower chamber, which is to be used ONLY for double acting applications. In TPS series models, this interface is plugged (threaded, weatherproof plug).

- To fix the control system in place (refer to Section 3.18).
- To hoist the actuator only by means of the provided lugs (refer to Section 3.18).
- To connect the shaft indicating the actuator status to the associated indicator device (refer to Section 3.18).
- To fix the position indicator in place (refer to Section 3.18).

3.7 Main Features

The main features of compact TPS series actuators are described below:

- The kinematic mechanism is available in 10 different sizes, each distinguished by the maximum deliverable structural torque, which cover a torque range: 500 to 300000 Nm.
- Each kinematic mechanism can be assembled to different cylinders and springs for the purpose of modulating the delivered torque according to the required valve performance, in its various determining positions, namely:
 - Valve unseating while opening (BTO)
 - Valve seating while opening (ETO)
 - Valve unseating while closing (BTC)
 - Valve seating while closing (ETC)
 - Intermediate positions (RUN)
- Each mechanism is available in two configurations distinguished by the different helical spline profiles in order to modulate the profile of the operating torque delivered by the actuator.

Table 2. Constant and Variable Helical Spline Profiles

Type of Profile	Operating Torque
RP - Constant helical spline profile	The operating torque reproduces the typical torque generated by a "rack/pinion" kinematic gear.
SY - Variable helical spline profile	The operating torque is similar to the typical torque generated by a scotch yoke mechanism.

- Both OP and CL configurations are available.

Table 3. Configuration Definitions

Type of Profile	Operating Torque
OP - Spring to open	In case of pneumatic supply failure, the actuator generates, by means of the spring, a counterclockwise rotation (and torque) to open the valve.
CL - Spring to close	In case of pneumatic supply failure, the actuator generates, by means of the spring, a clockwise rotation (and torque) to close the valve.



Product range (type of mechanism and cylinder size): Refer to Table 4.

NOTE:

Pursuant to Standard ISO 5211, (clockwise direction of rotation to close the valve), in TPS series actuators:

- The CL configuration (spring to close), where the valve is closed by the spring, is obtained by the right hand travel of the helical spline.
- The OP configuration (spring to open), where the valve is opened by the spring, is obtained by the left hand travel of the helical spline.

Table 4 below contains data regarding:

Size and type of TPS series actuators, each associated to its Maximum Operating Torque (MOT) plus the type of spring and pneumatic cylinder, identified by the Nominal Diameter (DN), applicable to each size.

Table 4. Output Torque Curve Type – Cylinders – Springs

Size	Output Torque Curve Type			Pneumatic Cylinder			Type of Spring		
	Helical Spline Profile Type	MOT (Nm)		DN (mm)			For TPS Series		
0.A	RP	SY	500	-	-	175	1	2	-
0.1	RP	SY	1000	-	235	280	1	2	3
0.3	RP	SY	3000	280	335	385	1	2	3
0.9	RP	SY	9000	385	435	485	1	2	3
1.5	RP	SY	15000	485	535	585	1	2	3
3	RP	SY	30000	585	635	685	1	2	3
6	RP	SY	60000	735	785	835	1	2	3
14	RP	SY	120000	-	-	1000	1	2	3
18	RP	SY	160000	-	-	1100	1	2	3
32	RP	SY	300000	-	-	1300	1	2	3

NOTICE

Biffi Italia s.r.l. reserves the right to make changes without notice with respect to the data. For updated information, please refer to Biffi Italia s.r.l. website, catalogues, etc.

3.8 Options and Configurations

The design solutions and the characteristics of the materials make the TPS Series actuators suitable for use in different environmental conditions and temperature ranges.

- The three different available configurations make the actuator suitable for the temperature ranges listed in Table 5 below;
- It is also possible, upon customer's request, to use stainless steel for some of the structural components, treatments or materials in order to obtain tightness measures different from what provided by standard configurations.

Table 5. Environmental Operating Conditions

Environmental Conditions	Δt	Optional: External Parts Threaded in Stainless Steel
* Standard	-20 to +100 °C	✓
* Special	-40 to +100 °C	✓
Extreme	-60 to +100 °C	✓

NOTES:

✓ Provided

✗ Not provided

* Pressurized parts pursuant to PED Directive 97/23/EC (until 18/07/2016) or 2014/68/EU (from 19/07/2016).

3.9 Accessories

TPS Series actuators can be equipped, upon request, with various types of accessories, such as:

- "Manual override" device (actuator is operated manually in case of pneumatic supply failure)
- Valve status indicator device (microswitch box, positioner, sundry items)
- Control panel
- Sundry items

As already mentioned in Section 3.1, the present manual DOES NOT contain any instruction as regards the use or maintenance of any of the accessories installed on TPS series actuators, for which you are kindly requested to refer to the documentation relative to the order acknowledgement (of which this manual is an integral part).

3.10 Reading and Understanding the Product ID Code

The meaning of the actuator model code featured on the rating plate (Refer to Section 3.2) is explained in the table below:

Table 6. Explanation of Product ID

	TP	S	0.3	RP	1	385	CL
Type	TP Series						
Function	S = single-acting						
	D = double-acting						
Actuator size	0.A 0.1 0.3 0.9 1.5						
	3 6 14 18 32						
Output Torque Curve Type	RP type ⁽¹⁾						
	SY type ⁽¹⁾						
Type of spring	1		2		3		
Cylinder size	Refer to Table 4						
Safety function	CL = Fail to close/Spring-closed						
	OP = Fail to open/Spring-opened						

NOTES:

1 - Refer to Table 2.

NOTE:

The actuator ID code DOES NOT feature the data specified below (in that regard, please refer to the documentation relative to the order acknowledgement):

- Type of interface used to couple the actuator to the valve
- Type of accessory used for manual override operations
- Seal configuration and materials for each temperature range
- Optional: use of stainless steel for external threaded parts that have a structural function.

3.11 Main Components and Materials

3.11.1 TPS 0.A Actuator

This section contains a list of the main components of TPS 0.A actuator and the type of material used in their manufacture.

Figure 3. Main Components and Materials – TPS 0.A

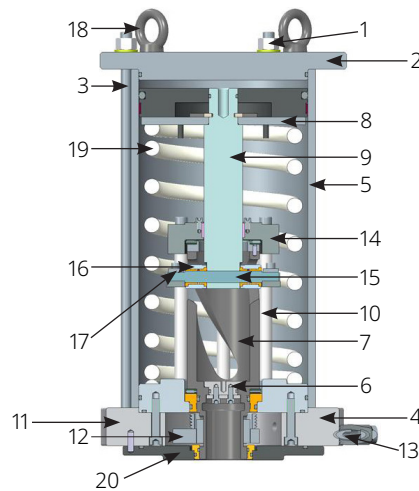


Table 7. Parts List

Item	Description	Material	Item	Description	Material
1	Tie rod nut	Alloy steel or stainless steel (optional)	11	Base	Carbon steel
2	End flange	Carbon steel	12	Sector for adjustment	Carbon steel
3	Tie rod	Alloy steel or stainless steel (optional)	13	Stopper + Cover	Alloy steel or stainless steel (optional)
4	Head flange	Carbon steel	14	Upper flange	Carbon steel
5	Cylinder	Carbon steel	15	Pin	Carbon steel
6	Output drive plug	Carbon steel	16	Bars	Chromium-plated steel
7	Output drive	Alloy steel	17	Guide ring	Aluminium bronze alloy
8	Piston	Carbon steel	18	Lugs	Carbon steel
9	Stem	Alloy steel	19	Spring	Alloy steel
10	Central tube	Carbon steel	20	Lower flange	Carbon steel

NOTE:

Please refer to the documentation relative to the order acknowledgement for further details about the specifications of all spare parts materials and of the relevant reference standard.

3.11.2 TPS 0.1/0.3/0.9/1.5/3 Actuators

This section contains a list of the main components of TPS 0.1/0.3/0.9/1.5/3 actuators and the type of material used in their manufacture.

Figure 4. Main Components and Materials – TPS 0.1/0.3/0.9/1.5/3

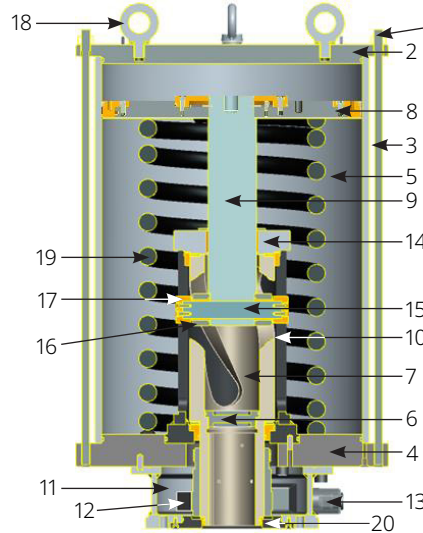


Table 8. Parts List

Item	Description	Material	Item	Description	Material
1	Tie rod nut	Alloy steel or stainless steel (optional)	11	Base	Carbon steel
2	End flange	Carbon steel	12	Sector for adjustment	Carbon steel
3	Tie rod	Alloy steel or stainless steel (optional)	13	Stopper + Cover	Alloy steel or stainless steel (optional)
4	Head flange	Carbon steel	14	Upper flange	Carbon steel
5	Cylinder	Carbon steel	15	Pin	Carbon steel
6	Output drive plug	Carbon steel	16	Roller + Bushing	Alloy steel + Aluminium Bronze Alloy
7	Output drive	Alloy steel	17	Sliding ring	Aluminium bronze alloy
8	Piston	Carbon steel	18	Lugs	Carbon steel
9	Stem	Alloy steel	19	Spring	Alloy steel
10	Central tube	Carbon steel	20	Lower flange	Carbon steel

NOTE:

Please refer to the documentation relative to the order acknowledgement for further details about the specifications of all spare parts materials and of the relevant reference standard.

3.11.3 TPS 6 Actuator

This section contains a list of the main components of TPS 6 actuators and the type of material used in their manufacture.

Figure 5. Main Components and Materials - TPS 6

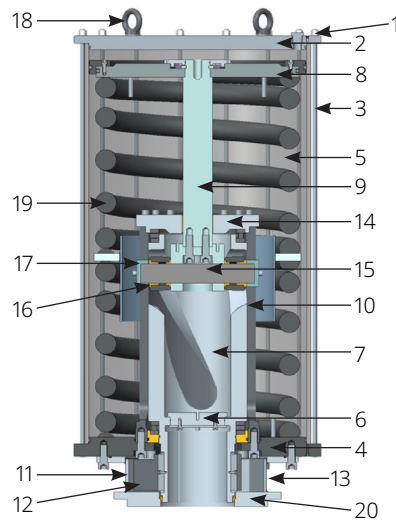


Table 9. Parts List

Item	Description	Material	Item	Description	Material
1	Tie rod nut	Alloy steel or stainless steel (optional)	11	Base	Carbon steel
2	End flange	Carbon steel	12	Sector for adjustment	Carbon steel
3	Tie rod	Alloy steel or stainless steel (optional)	13	Stopper + Cover position (not visible in this section)	Alloy steel or stainless steel (optional)
4	Head flange	Carbon steel	14	Upper flange	Carbon steel
5	Cylinder	Carbon steel	15	Pin	Carbon steel
6	Output drive plug	Carbon steel	16	Roller + Bushing	Alloy steel + Aluminium Bronze Alloy
7	Output drive	Alloy steel	17	Sliding ring	Aluminium bronze alloy
8	Piston	Carbon steel	18	Lugs	Carbon steel
9	Stem	Alloy steel	19	Spring	Alloy steel
10	Central tube	Carbon steel	20	Lower flange	Carbon steel

NOTE:

Please refer to the documentation relative to the order acknowledgement for further details about the specifications of all spare parts materials and of the relevant reference standard.

3.11.4 TPS 14/18/32 Actuators

This section contains a list of the main components of TPS 14/18/32 actuators and the type of material used in their manufacture.

Figure 6. Main Components and Materials - TPS 14/18/32

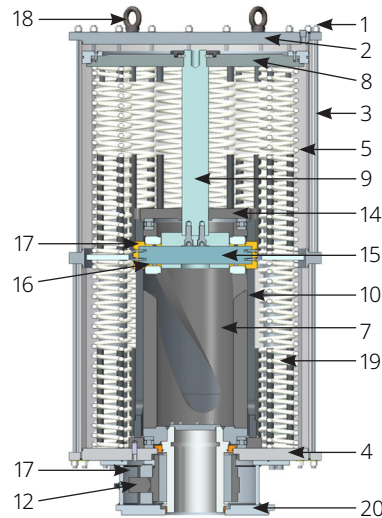


Table 10. Parts List

Item	Description	Material	Item	Description	Material
1	Tie rod nut	Alloy steel or stainless steel (optional)	11	Base	Carbon steel
2	End flange	Carbon steel	12	Sector for adjustment	Carbon steel
3	Tie rod	Alloy steel or stainless steel (optional)	13	Stopper + Cover position (not visible in this section)	Alloy steel or stainless steel (optional)
4	Head flange	Carbon steel	14	Upper flange	Carbon steel
5	Cylinder	Carbon steel	15	Pin	Carbon steel
6	Output drive plug	Carbon steel	16	Roller + Bushing	Alloy steel + Aluminium Bronze Alloy
7	Output drive	Alloy steel	17	Sliding ring	Aluminium bronze alloy
8	Piston	Carbon steel	18	Lugs	Carbon steel
9	Stem	Alloy steel	19	Spring	Alloy steel
10	Central tube	Carbon steel	20	Lower flange	Carbon steel

NOTE:

Please refer to the documentation relative to the order acknowledgement for further details about the specifications of all spare parts materials and of the relevant reference standard.

3.12 Technical Data

3.12.1 General Data

Table 11. General Technical Data

Description	Value	Unit of Measure
Maximum allowable pressure	12 ^(1,2)	bar
	174.05 ^(1,2)	psi
Operating pressure	See ID plate	
Operating temperature range – standard applications	-20 to +100	°C
	-4 to 212	°F
Operating temperature range – special applications	-40 to +100	°C
	-40 to +212	°F
Operating temperature range – extreme applications	-60 to +100	°C
	-76 to +212	°F
Supply fluid	Instrument air or nitrogen	
Storage temperature (Refer to Section 6.2)	-	-
Storage environment humidity (Refer to Section 6.2)	-	-

NOTES:

1. The hydraulic circuit must be absolutely protected from any pressure values exceeding the value shown in Table 11 by means of a safety valve. The safety valve limits the pressure inside the hydraulic circuit and intervenes if the maximum allowable pressure is exceeded. The safety valve can be supplied by Biffi Italia s.r.l. inside the control panel.
2. Refer to the technical documentation (namely to the hydraulic diagrams) in order to verify the presence of an overpressure valve that limits the pressurization of the hydraulic circuit above the maximum allowable pressure shown in Table 11.

CAUTION

It is strictly forbidden to exceed the maximum allowable pressure detailed in Table 11.

NOTE:

The actuator ID code (Section 3.10) DOES NOT feature the data specified hereafter (in that regard, please refer to the documentation relative to the order acknowledgement): seal configuration and materials for each temperature range.

3.12.2 Overall Dimensions, Weights and Estimated Center of Gravity Position

Figure 7. TPS Actuator Dimensions

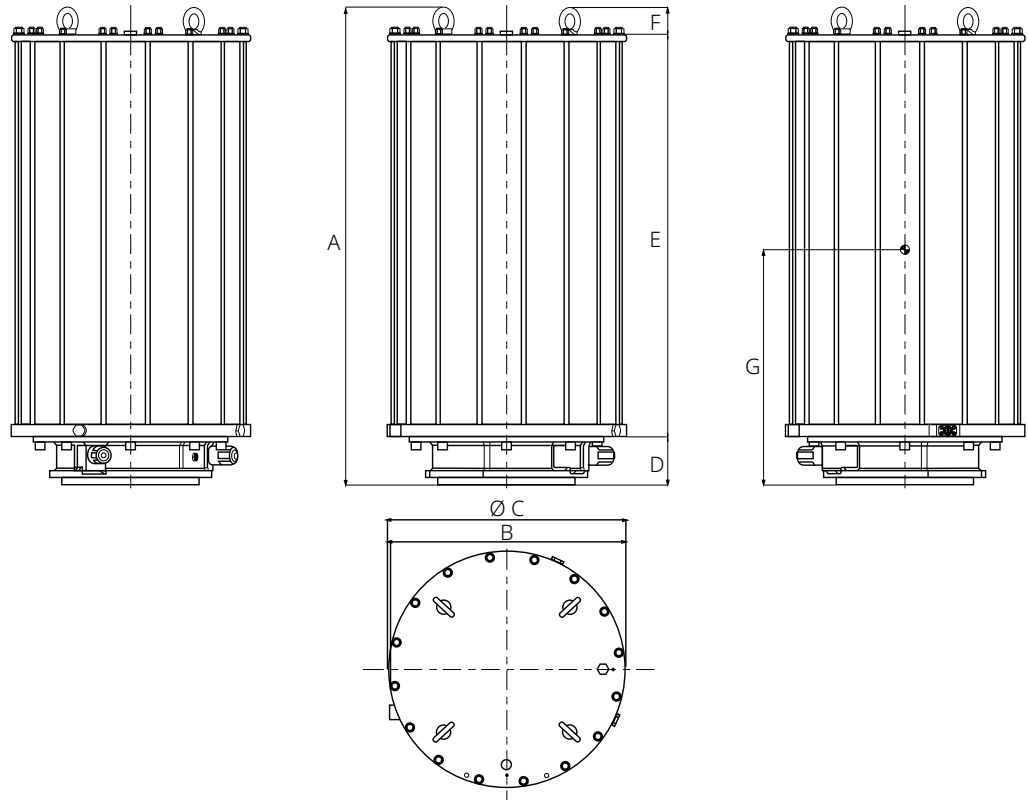


Table 12. Technical Data for Each Model

Model of Actuator	Dimensions (mm)							Weight (kg)		
	A	B	Ø C	D	E	F	G	xxk	xxk	xxk
	xx = RP/SY; k = 1/2/3							RP1/SY1	RP2/SY2	RP3/SY3
TPS 0.A xxk 175 CL/OP	475	312	255	20	410	45	214	65	64	-
TPS 0.1 xxk 235 CL/OP	610	374	325	50	507	53	275	145	140	-
TPS 0.1 xxk 280 CL/OP	610	394	365	50	507	53	275	165	160	165
TPS 0.3 xxk 280 CL/OP	700	390	365.5	50	592	53	315	200	185	-
TPS 0.3 xxk 335 CL/OP	700	445	420.5	50	595	53	315	245	230	265
TPS 0.3 xxk 385 CL/OP	700	495	470.5	50	595	53	315	285	270	310
TPS 0.9 xxk 385 CL/OP	975	495	465	115	782	53	439	450	415	-
TPS 0.9 xxk 435 CL/OP	975	540	515	115	782	53	439	495	465	525
TPS 0.9 xxk 485 CL/OP	975	600	580	115	782.5	53	439	565	535	600
TPS 1.5 xxk 485 CL/OP	1100	600	580	125.5	884.5	74	495	710	680	-
TPS 1.5 xxk 535 CL/OP	1100	650	630	125.5	886.5	74	495	780	745	810
TPS 1.5 xxk 585 CL/OP	1100	700	680	125.5	891.5	74	495	860	830	900
TPS 3 xxk 585 CL/OP	1321	700	680	140	1107	74	594	1205	1155	-
TPS 3 xxk 635 CL/OP	1321	748	735	140	1107	74	594	1325	1275	1385
TPS 3 xxk 685 CL/OP	1321	800	785	140	1107	74	594	1410	1360	1470
TPS 6 xxk 735 CL/OP	1679	840	835	170	1415	94	756	2455	2345	-
TPS 6 xxk 785 CL/OP	1679	900	895	170	1415	94	756	2585	2495	2660
TPS 6 xxk 835 CL/OP	1679	950	945	170	1415	94	756	2710	2620	2790
TPS 14 xxk 935 CL/OP	2070	1054	1060	190	1748	132	931	3710	3650	3770
TPS 14 xxk 1000 CL/OP	2070	1120	1125	190	1748	132	931	3965	3905	4025
TPS 18 xxk 1000 CL/OP	2356	1120	1125	240	1978	138	1060	5120	5130	5280
TPS 18 xxk 1100 CL/OP	2356	1221	1230	240	1978	138	1060	5615	5630	5780
TPS 32 xxk 1200 CL/OP	2698	1326	1335	290	2269	138	1214	7670	7635	7670
TPS 32 xxk 1300 CL/OP	2698	1426	1435	290	2269	138	1214	8327	8289	8327

NOTES:

- With reference to Section 3.10, the alphanumeric **xxk** sequence, featured in the identification code of the actuator model, is indicated:
 - Generally, in the columns containing dimension data, because the external dimensions depend neither on the kinematic mechanism type (xx = RP/SY) nor on the type of spring (k = 1/2/3).
 - Specifically, in the columns containing weight data according to the type of spring.
- Overall dimensions and weights are the same in both Fail to Close (CL) and Fail to Open (OP) configurations for each actuator model.

NOTE:

For the overall dimensions and the weight, please refer to the confirmation documentation.

3.13 Valve Coupling Interface (Top Mounting)

TPS series actuators allow direct coupling to the valve (without having to use a stub). The standard options for valve coupling interfaces available for TPS series actuators are listed below:

NOTE:

Refer to the confirmation documentation in order to verify if the top mounting complies with the standard solutions listed in the present document or if it is a custom solution for which the presence of a stud (spool piece) can be provided.

- **Standard – ISO 5211**

In standard configuration, TPS series actuators are provided with a coupling interface compliant with Standard ISO 5211 (Refer to Table 14) which allows direct coupling to the valve if the coupling flanges of valve and actuator belong to the same coupling class (for instance, both flanges are F30 class).

NOTE:

For sizes and dimensions, please refer to Biffi document SCN 7976.

- **Custom ISO 5211**

In some configurations, TPS series actuators allow direct coupling to the valve even if the coupling flanges belong to different coupling classes, pursuant to Standard ISO 5211 (Refer to Table 15). In that case, the actuator interface flange is provided with bore sizes that are compliant with Standard ISO 5211, but belong to a coupling class that is lower than the actuator maximum operating torque. For instance, the actuator torque output is consistent with class F30, but the valve coupling interface has an F25 class bore size.

NOTE: The safety factors required by the customer's specifications when sizing the actuator performance with respect to the torque values required by the valve, can determine the choice of an actuator belonging to a coupling class higher than that of the valve (considering the coupling classes compliant with Standard ISO 5211). The interface Custom ISO 5211 allows, also in such case, direct coupling without having to use an interface flange or stub.

NOTE:

For sizes and dimensions, please refer to Biffi document SCN 7977.

- **Compatible with Biffi ALGA/ALGAS Series**

TPS Series actuators can be provided with a customized interface (Refer to Table 16), which, as regards size, is compliant and compatible with Biffi ALGA/ALGAS product line in their standard configuration.

NOTE: This type of interface requires, as for ALGA/ALGAS, the use of an interface flange or spool piece. This option allows an ALGA/ALGAS model to be replaced by a TP series model.

NOTE:

For sizes and dimensions, please refer to Biffi document SCN 7975.

In short, TPS series actuators can be provided with three different valve coupling interfaces, as shown in Table 13:

Table 13. Types of Valve Interfaces

Standard - ISO 5211	Custom ISO 5211	Custom ALGA/ALGAS Interchangeable
This configuration allows actuator-to-valve direct coupling if the coupling flange sizes are compliant with Standard ISO 5211 and belong to the same coupling class.	This configuration allows actuator-to-valve direct coupling if the coupling flange sizes are compliant with Standard ISO 5211, but the valve flange belongs to a coupling class lower than that of the actuator.	Where applicable, the coupling interfaces of TPS and ALGA/ALGAS series actuators having the same size can be interchanged.

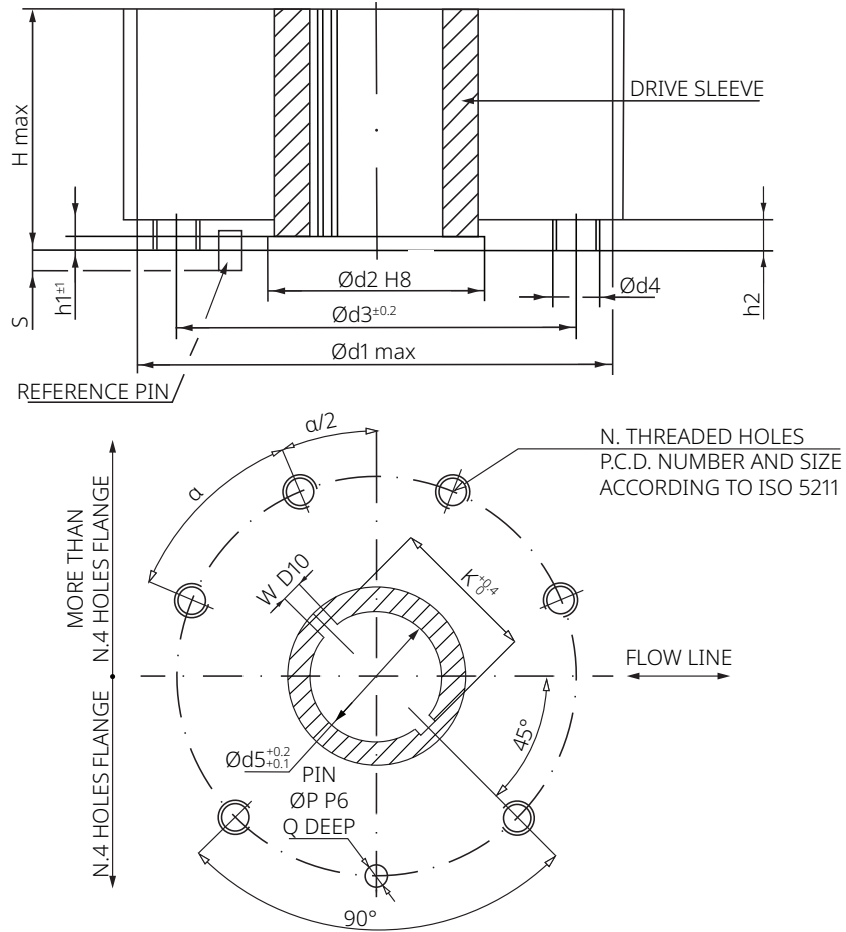
The drawings and geometrical data of the three different interfaces (Tables 14, 15 and 16) are given in the following pages.

NOTE:

Please refer to the documentation relative to the order acknowledgement to check the type of valve coupling interface (top mounting) provided with the supplied actuator.

2. CUSTOM ISO 5211 INTERFACE (extract from document SCN 7977)

Figure 9. Custom ISO 5211 Interface



TOP VIEW OF THE OUTPUT DRIVE (ACTUATOR SHOWN IN CLOSED POSITION)

Table 15. Technical Data for Custom Flanges Compliant with ISO 5211

Actuator Model	Flange	Ød1 max	Ød3	Ød4	N	h2	H max	Ød5	W	K	α	Ød2	h1	ØP	Q	S
TPS 0.A xxk - zzzz CL/OP	-	-	-	-	-	-	-	-	-	-	-	-	-	-	-	-
TPS 0.1 xxk - zzzz CL/OP	-	-	-	-	-	-	-	-	-	-	-	-	-	-	-	-
TPS 0.3 xxk - zzzz CL/OP	F14	210	140	M16	4	24	98	70	12	75.6	90°	93	5	16	10	20
TPS 0.9 xxk - zzzz CL/OP	F16	300	165	M20	4	22	172	86	14	93.6	90°	112	5	16	10	20
TPS 1.5 xxk - zzzz CL/OP	F25	350	254	M16	8	24	183	112	18	119.6	45°	144	6	16	10	20
TPS 3 xxk - zzzz CL/OP	F30	415	298	M20	8	22	224	157	25	167.8	45°	195	9	20	15	20
TPS 6 xxk - zzzz CL/OP	F35	475	356	M30	8	32	255	200	28	212.8	45°	250	14	20	15	20
TPS 14 xxk - zzzz CL/OP	F40	560	406	M36	8	38	295	175	45	195.8	30°	250	15	20	15	20
TPS 18 xxk - zzzz CL/OP	F48	686	483	M36	12	38	325	200	45	220.8	30°	276	15	20	20	25
TPS 32 xxk - zzzz CL/OP	F48	780	483	M36	20	38	365	220	50	242.8	30°	315	15	20	20	25

NOTES:

- With reference to Section 3.10, the alphanumeric sequences **xxk** and **zzzz**, featured in the identification code of the actuator model are not detailed, because the type of interface used for actuator to valve coupling depends NEITHER:
 - On the kinematic mechanism (xx = RP/SY) nor on the type of spring (k = 1/2/3)
 - Nor on the type of cylinder (zzzz)
- The above data are valid for both Fail to Close (CL) and Fail to Open (OP) configurations for each actuator model.

3. CUSTOM ALGA/ALGAS INTERCHANGEABLE INTERFACE (extract from document SCN 7975)

Figure 10. ALGA/ALGAS Interchangeable Interface

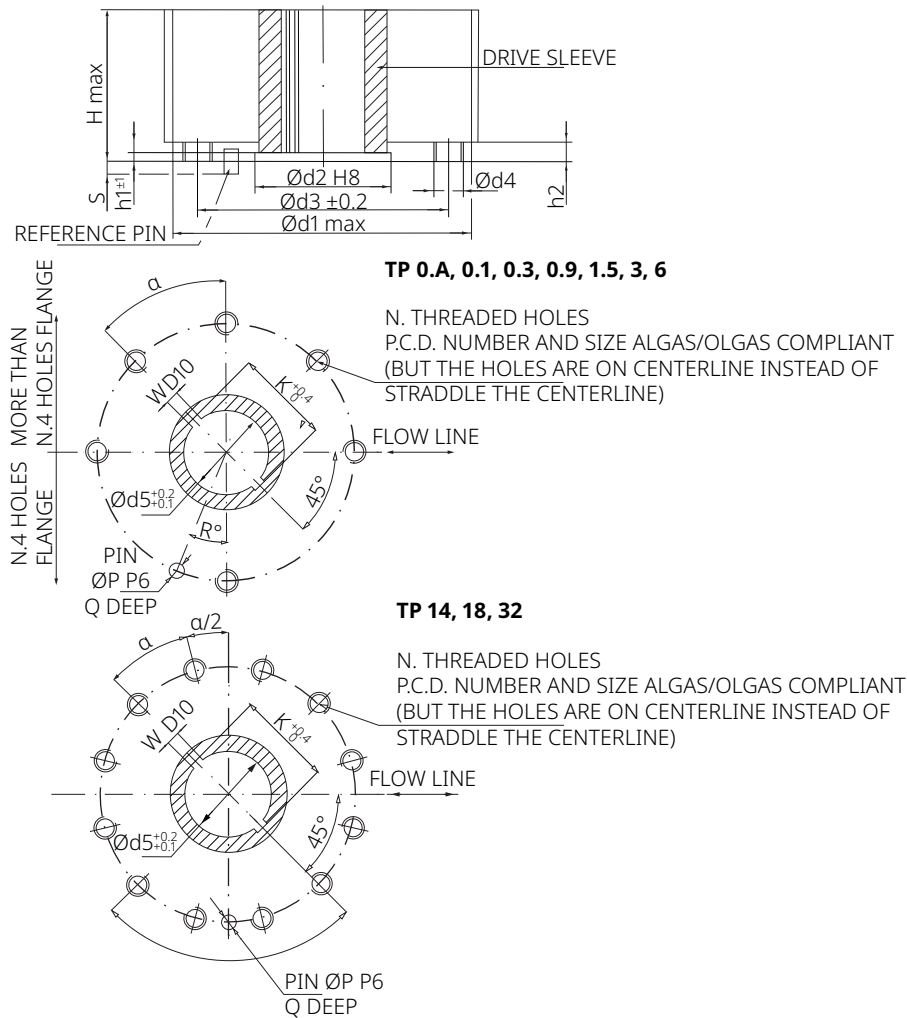


Table 16. Technical Data for Custom Flanges Interchangeable with ALGA/ALGAS Actuators

Actuator Model	Ød1 max	Ød3	Ød4	N	h2	H max	Ød5	W	K	Ød2	h1	ØP	Q	S	R°	α
TPS 0.A xxk - zzzz CL/OP	125	102	M10	4	12	56.5	36	6	41.6	70	5	5	5	5	22.5°	-
TPS 0.1 xxk - zzzz CL/OP	150	125	M12	4	14	98	55	10	60.6	90	6	5	5	5	22.5°	-
TPS 0.3 xxk - zzzz CL/OP	210	165	M20	4	22	98	70	12	75.6	93	5	16	10	20	22.5°	-
TPS 0.9 xxk - zzzz CL/OP	300	254	M16	8	24	172	86	14	93.6	112	5	16	10	20	22.5°	45°
TPS 1.5 xxk - zzzz CL/OP	350	298	M20	8	22	183	112	18	119.6	144	6	16	10	20	22.5°	45°
TPS 3 xxk - zzzz CL/OP	415	356	M30	8	32	224	157	25	167.8	195	9	20	15	20	22.5°	45°
TPS 6 xxk - zzzz CL/OP	475	406	M36	8	38	255	200	28	212.8	250	14	20	15	20	22.5°	45°
TPS 14 xxk - zzzz CL/OP	560	483	M36	12	38	295	175	45	195.8	250	15	20	15	20	-	15°
TPS 18 xxk - zzzz CL/OP	686	603	M36	16	38	325	200	45	220.8	290	15	20	20	25	-	11.25°
TPS 32 xxk - zzzz CL/OP	780	603	M36	16	38	365	220	50	242.8	310	15	20	20	25	-	11.25°

NOTES:

- With reference to Section 3.10, the alphanumeric sequences **xxk** and **zzzz** featured in the identification code of the actuator model are not detailed, because the type of interface used for actuator to valve coupling depends on NETIHER:
 - On the kinematic mechanism (xx = RP/SY) nor on the type of spring (k=1/2/3)
 - Nor on the type of cylinder (zzzz)
- The above data are valid for both Fail to Close (CL) and Fail to Open (OP) configurations for each actuator model.

3.14 Connecting the Stem Valve

Documents SCN 7975, SCN 7976 and SCN 7977 also contain geometrical data as regards the output drive interface (actuator rotary element).

Since there are no standard geometrical data regarding the valve stem, Biffi Italia s.r.l. provides a bush insert or a sleeve, suitably machined, which allows a rigid connection between actuator and valve.

The above described connection element is supplied separately from the actuator and is used when the actuator is installed on the valve.

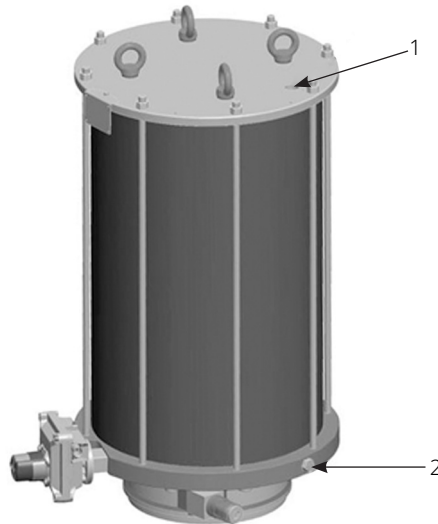
NOTE:

Please refer to the documentation relative to the order acknowledgement to check geometric consistency between the valve stem and the connection element/actuator.

3.15 Pneumatic Interfaces (TPS 0.A/0.1/0.3/0.9/1.5/3)

The actuators TPS 0.A/0.1/0.3/0.9/1.5/3 are provided with two pneumatic interfaces, as shown in Figure 11:

Figure 11. Position of Pneumatic Interfaces



1. Pneumatic interface supplying the upper chamber of the pneumatic cylinder. This interface is used:
 - For single-acting applications (TPS series models), in both configurations:
 - OP (spring to open)
 - CL (spring to close)
 - For double-acting applications (TPD series models)
2. Pneumatic interface supplying the lower chamber of the pneumatic cylinder. This interface is used for double-acting applications (TPD series models). In single-acting applications, the use of this pneumatic interface depends on the functions requested via the control panel. It could be plugged or connected to the control panel (if provided for) or it might not be fitted.

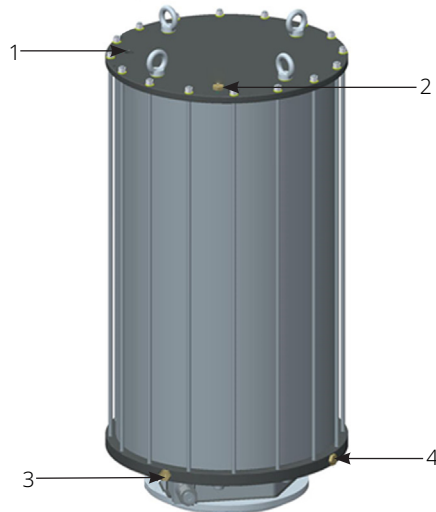
NOTE:

Please refer to the documentation relative to the order acknowledgement (in particular to the pneumatic functional diagram) to check the connection modes available for the pneumatic interfaces.

3.16 Pneumatic Interfaces (TPS 6)

The actuator TPS 6 is provided with two pneumatic interfaces supplying the upper chamber and two supplying the lower chamber:

Figure 12. Position of Pneumatic Interfaces



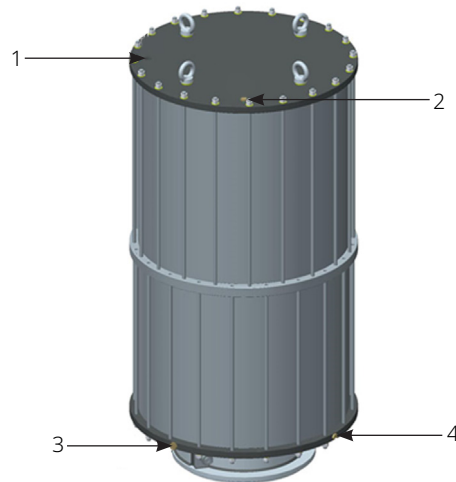
1 and 2	<p>Pneumatic interface supplying the upper chamber of the pneumatic cylinder. This interface is used:</p> <ul style="list-style-type: none"> • For single-acting applications (TPS series models), in both configurations: <ul style="list-style-type: none"> — OP (spring to open) — CL (spring to close) • For double-acting applications (TPD series models)
3 and 4	<p>Pneumatic interface supplying the lower chamber of the pneumatic cylinder. This interface is used for double-acting applications (TPD series models). In single-acting applications, the use of this pneumatic interface depends on the functions requested via the control panel. It could be plugged or connected to the control panel (if provided for) or it might not be fitted.</p>

NOTE:

Please refer to the documentation relative to the order acknowledgement (in particular to the pneumatic functional diagram) to check the connection modes available for the pneumatic interfaces.

3.17 Pneumatic Interfaces (TPS 14/18/32)

Figure 13. Position of Pneumatic Interfaces



1 and 2	<p>Pneumatic interface supplying the upper chamber of the pneumatic cylinder. This interface is used:</p> <ul style="list-style-type: none"> • For single-acting applications (TPS series models), in both configurations: <ul style="list-style-type: none"> — OP (spring to open) — CL (spring to close) • For double-acting applications (TPD series models)
3 and 4	<p>Pneumatic interface supplying the lower chamber of the pneumatic cylinder. This interface is used for double acting applications (TPD series models). In single-acting applications, the use of this pneumatic interface depends on the functions requested via the control panel. It could be plugged or connected to the control panel (if provided for) or it might not be fitted.</p>

NOTE:

Please refer to the documentation relative to the order acknowledgement (in particular to the pneumatic functional diagram) to check the connection modes available for the pneumatic interfaces.

The pneumatic interfaces fitted on each TPS series model are listed in Table 17 below.

Table 17. Pneumatic Interfaces and Air Consumption

Model	Pneumatic Interface 1 (Pursuant to Standard NPT)	Pneumatic Interface 2 (Pursuant to Standard NPT)	Displacement (Liters)
TPS 0.A xxk 175 CL/OP	1/2 in.	1/4 in.	2.4
TPS 0.1 xxk 235 CL/OP	3/4 in.	1/2 in.	5.3
TPS 0.1 xxk 280 CL/OP	3/4 in.	1/2 in.	7.6
TPS 0.3 xxk 280 CL/OP	3/4 in.	1/2 in.	10
TPS 0.3 xxk 335 CL/OP	1 in.	1/2 in.	15
TPS 0.3 xxk 385 CL/OP	1 in.	1/2 in.	20
TPS 0.9 xxk 385 CL/OP	1 in.	3/4 in.	24
TPS 0.9 xxk 435 CL/OP	1 in.	3/4 in.	30
TPS 0.9 xxk 485 CL/OP	1 in.	3/4 in.	37
TPS 1.5 xxk 485 CL/OP	1 in.	3/4 in.	49
TPS 1.5 xxk 535 CL/OP	1 in.	3/4 in.	60
TPS 1.5 xxk 585 CL/OP	1 in.	3/4 in.	71
TTPS 3 xxk 585 CL/OP	1 in.	3/4 in.	90
TPS 3 xxk 635 CL/OP	1 in.	3/4 in.	105
TPS 3 xxk 685 CL/OP	1 in.	1 in.	123
TPS 6 xxk 735 CL/OP	1 in.	1 in.	174
TTPS 6 xxk 785 CL/OP	1 in.	1 in.	198
TPS 6 xxk 835 CL/OP	1 in.	1 in.	224
TPS 14 xxk 935 CL/OP	1 in.	1 in.	355
TPS 14 xxk 1000 CL/OP	1 in.	1 in.	405
TPS 18 xxk 1000 CL/OP	1 in.	1 in.	485
TPS 18 xxk 1100 CL/OP	1 in.	1 in.	587
TPS 32 xxk 1200 CL/OP	1 in.	1 in.	832
TPS 32 xxk 1300 CL/OP	1 in.	1 in.	977

NOTE:

With reference to Section 3.10, the alphanumeric xxk sequence featured in the identification code of the actuator model is not detailed. The pneumatic interface depends NEITHER on the kinematic mechanism (xx = RP/SY) nor on the spring (k = 1/2/3).

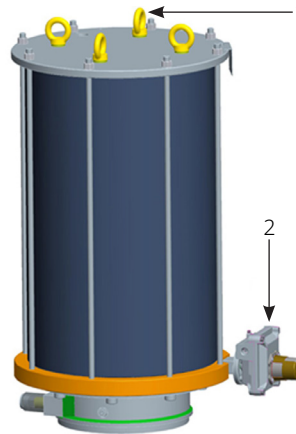
NOTE:

Generally speaking, displacement refers to the volume of air required for the complete execution of a closing or opening function of the valve (depending on the CL/OP configuration), when the thrust on the kinematic mechanism of the actuator is exerted by the pneumatic cylinder. With regard to the values indicated in Table 17 displacement refers to the volume of air required to supply the pneumatic cylinder via pneumatic interface 1.

3.18 Other Interfaces, Devices and Accessories

Figure 14 shows the typical position on a generic model of the TPS series of the following types of interfaces:

Figure 14. Position of Interfaces, Devices and Accessories



1. Lifting lugs

Used for vertical lifting; for their use, please refer to Section 5: Transport and Handling. The actuator can also be provided with eyes for horizontal lifting, see Section 5.2.1.

2. Valve status indicator device

The diagnostic information regarding the valve status is obtained by means of a shaft directly connected to the output drive via mechanical transmission. (Figure 14) shows one of the possible devices in place).

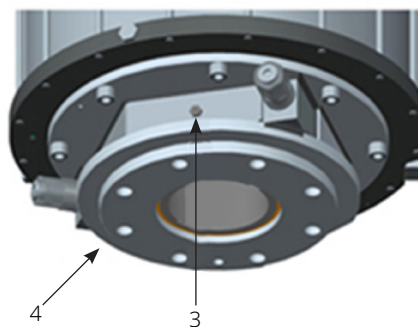
3. Overpressure valve

Its function is to prevent the actuator lower chamber from being pressurized (both the lower chamber of the pneumatic cylinder and the base) (see also the first NOTE on the next page) in the event of a failure in the seal tightness of the piston.

4. Actuator earth grounding interface

All TPS series actuators are provided with a threaded interface on the base (4) for the earth connection.

Figure 15. Lower View with Example of Overpressure Valve Positioning



NOTICE

Depending on the plant configuration, the valve shown in Figure 15 can be replaced by a plug. Refer to the confirmation documentation (namely the pneumatic functional diagrams) in order to verify the presence of the over pressure valve for preventing the actuator lower chamber from being pressurized (both the lower chamber of the pneumatic cylinder and the base).

NOTICE

Make sure the earth grounding interface on the actuator (refer to Figure 15) is connected to the control panel, to prevent the risk of electrostatic charges.

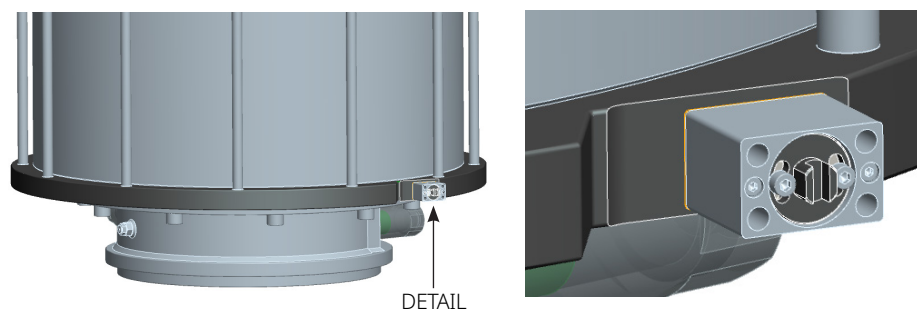
The head and end flanges are provided with bores to which specific brackets are fastened for the control panel installation.

NOTE:

Biffi Italia s.r.l. can provide different types of control system to meet the customer's specifications, for which you can refer to the documentation relative to the order acknowledgement.

The connection and coupling interface of the position indicator device is located in the lower part of the actuator (refer to Figure 16 - detail).

Figure 16. Detail of Connection and Coupling Interface of Valve Status Indicator Device

**NOTE:**

Any indicator device requested by the customer can be installed by means of a customizable coupling and flange (both provided by Biffi Italia s.r.l.), for which you can refer to the documentation relative to the order acknowledgement.

3.19 Minimum Requirements for Installing Control, Signalling and Diagnostic Devices on Board the Actuator

NOTICE

To prevent degradation of the features of TPS series actuators, specified by the marking pursuant to Directive 94/9/EC (ATEX) (refer to Figure 1), only equipment having the same type of marking or superior features are suitable for installation on board the actuator.

Section 4: Health and Safety Provisions

4.1 Introduction

Notwithstanding the fact that:

1. The actuator described in this manual has been designed using the latest technologies, so that it can be operated by trained and qualified personnel under conditions of utmost safety;
2. The personnel should be trained in aspects of general safety provisions, as regards those in force in the country where the actuator is installed and those valid for the plant in which the actuator is installed,

All staff members must be aware that distraction, overconfidence in performing operating and maintenance procedures, non-observance of safety provisions and inexperience can all result in severe accidents and cause damage to persons and property.

Therefore, operators and maintenance technicians interacting with the actuator should:

- Read and understand the contents of the entire "Installation, Operation and Maintenance Manual" and of the enclosed documentation.
- Be always aware that paying attention is essential to preventing damage to both staff and actuator: no safety system or code of practice can guarantee absolute safety, unless staff members interact with the actuator in a professional, accurate and scrupulous manner.

NOTE:

Biffi Italia s.r.l. shall in no way be liable for any damages or accidents to persons or property resulting from failure to comply with:

- The contents of this Installation, Operation and Maintenance Manual;
 - The code of practice as regards the use of the actuator specified by Biffi Italia s.r.l.;
 - The current health and safety regulations;
 - The instructions provided by the suppliers of commercial parts.
-

4.2 Duties of the Safety Officer

The duties of the safety officer are basically the following:

CIRCULATION OF SAFETY INFORMATION

The information included in this manual must be disclosed to all personnel in charge of:

- Actuator transport and handling
- Installation and commissioning
- Adjustment, operation and cleaning
- Maintenance
- Final dismantling

MONITORING AND SUPERVISION

All information and code of practice provisions must be observed by the staff interacting with the actuator:

- Staff members accessing the actuator must be skilled and trained
- Access to "danger zones" must be permitted to authorized personnel only
- All staff members interacting with the actuator must be considered "exposed person"
- Operators must be especially knowledgeable on the actuator's intended use, misuses, limitation of use, process materials and performance limits

The definitions of danger zone and exposed person are laid down in Annex 1 of Machinery Directive 2006/42/EC, Section 1 – "Essential health and safety requirements", Section 1.1.1 – "Definitions". The "Definitions" are reported in full hereunder:

- «Danger zone»: any zone within and/or around machinery in which an exposed person is subject to a risk to his health or safety;
- «Exposed person»: any person wholly or partially in a danger zone.

4.3 Duties of the Staff Interacting with the Actuator

Operators

They must promptly inform their immediate superior of any fault detected on the actuator, so that the situation can be resolved in good time and any potential future danger avoided.

Maintenance technicians

They must perform adequate preventative maintenance on the actuator, assign repairs to skilled technicians and always use genuine spare parts. The instructions contained in this manual and in the enclosed documentation, as regards the required competence to carry out maintenance activities, must be closely observed at all times.

4.4 Residual Risks

Residual risks refer to those hazards that are identified, but cannot be completely eliminated through design, mechanical, electrical or functional solutions, because they are intrinsically related to the nature and application of the machine. Such risks can and must be avoided by observance of the relevant codes of practice specified by the manufacturer.

Personal experience, caution and attention in every operation performed on the machine are essential factors of safety, which no code of practice can replace.







Table 18. Main Residual Risk Table

Risk	Cause	Code of Practice
Partial or extensive removal of external layers applied to protect against atmospheric corrosion	a) Accidental fall during transport	a1) Observance of the indications regarding transport and handling, specified in Section 5. a2) Prevention of improper use: in case of scratches or dents, have the actuator checked by skilled and authorized staff, or else return it to the manufacturer.
Reduction or total loss in performance for damages caused by violent impacts	a) Accidental fall during transport	a1) Observance of the indications regarding transport and handling, specified in Section 5. a2) Prevention of improper use: Have the actuator checked by skilled and authorized staff, or else return it to the manufacturer.
Accidental working fluid leak or explosion	a) Reduced material thickness b) Overpressure	a1) Avoid contact with corrosive substances. a2) Check for wear or corrosion on a regular basis, because these cannot be totally eliminated as they depend on the actuator environmental and operating conditions. b) Ensure that the actuator is not exposed to heat sources or placed in excessively hot environments.

4.5 Information on Personal Protective Equipment (PPE)

Before proceeding with any type of intervention, assigned staff must be equipped with suitable personal protective equipment suitable for the job to be carried out. The type of PPE to be used is decided by the Safety Officer appointed by the employer. Nonetheless, in the table below are listed some of the PPE that Biffi Italia s.r.l. suggests to have always available because their usage represents the minimum safety level that must be guaranteed to all personnel interacting with the actuator during any transport, installation, processing, maintenance and disposal stage.

Table 19. Personal Protective Equipment

Piece of Equipment	Type of Protection	Operations Requiring its Use
	GLOVES Hand protection against contact with sharp objects or substances that are skin irritant or toxic	- Contact with sharp objects. - Contact with cleaning equipment. - Contact with lubricant grease or oil. - Actuator lifting or handling operations.
	OVERALLS Protection against risk of trapping, dragging and direct skin contact with irritant or toxic substances	- Contact with sliding or moving parts. - Difficult access to operational areas. - Contact with cleaning equipment. - Contact with lubricant grease or oil.
	HELMET Head protection against abrasion hazard from cuts or impacts and against brain damage hazard from impact	- Difficult access to operational areas. - Access to areas with potential slip hazard. - Access to areas with suspended loads. - Actuator lifting or handling operations.
 	GOGGLES and FACE MASK Eyes and face protection against possible contact with irritant or toxic substances	- Contact with lubricant grease or oil. - Interventions on or contact with pressurized parts. - Actuator cleaning operations. - Proximity to machine parts that could eject pressurized fluids.
	SAFETY BOOTS Feet protection against crushing, cutting and slipping hazards	- Maintenance interventions. - Cleaning operations. - Actuator lifting or handling operations. - Assembling/disassembling the actuator or its components.

The use of PPE is mandatory for the staff members specified below:

- Operators
- Maintenance technicians

Consider whether to have spare PPE available for external personnel that might be authorized, for whatever reason, to interact with the actuator.



For further information:

Local regulations in force with regard to health and safety at work.

Section 5: Transport and Handling

5.1 Transport of the Actuator

5.1.1 General Information

NOTE:

The actuator is packed and transported by Biffi Italia s.r.l.

TPS actuators can be transported either already assembled to the valve or still separated from it therefore, depending on the type of conveyance, different provisions will have to be observed, as described below:

Conveyance of actuator only

Before using the actuator, make all relevant adjustments as indicated in the present manual.



For further information:
Section 6.

Conveyance of assembled actuator + valve group

Adjustments are made beforehand, therefore no checks need to be made before installation.

PPE to be used for lifting and handling operations:

Weights:
Refer to Table 12.

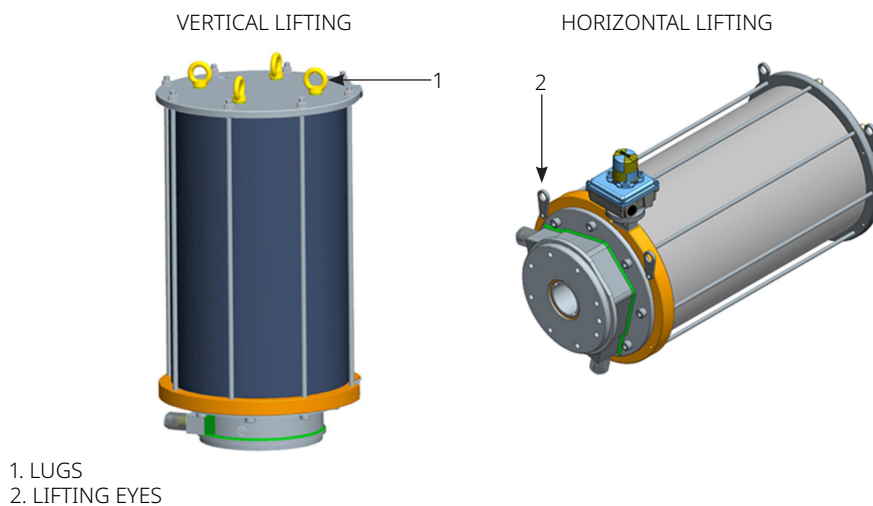
5.2 Lifting the Actuator

5.2.1 Lifting Points

The actuator is provided with lifting points for lifting and handling it:

- A. Rig the slings through the lugs located at the top of the actuator. Lift the actuator (without valve) by keeping it in vertical position.
- B. The actuator can also be provided with lifting eyes through which the slings shall be rigged in order to lift the actuator (without valve) by keeping it in horizontal position.

Figure 17. Lugs/Eyes for Lifting the Actuator Only

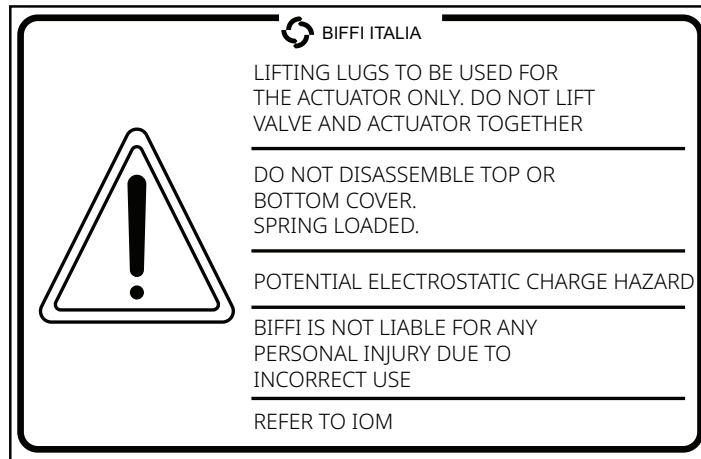


⚠ WARNING

The lugs/eyes fitted on the actuator are designed to lift exclusively the actuator WITHOUT the valve.

For a correct use of the lifting lugs/eyes, please refer to the adhesive plate shown in Figure 18 below.

Figure 18. Adhesive Plate



For lifting and moving the actuator, use only hooks fitted with safety latch, like the one shown in Figure 19:

Figure 19. Example of Hook with Safety Latch



5.2.2 Codes of Practice for Lifting Operations

WARNING

The lugs/eyes fitted on the actuator are designed to lift exclusively the actuator WITHOUT the valve.

NOTE:

Lifting and handling operations must be performed by adequately skilled personnel, pursuant to relevant current regulations.

- Wear protective clothing (helmet, gloves, overall, safety shoes, etc.).
- Use lifting equipment of adequate load limit.
- For lifting unbalanced loads, use ropes of different lengths or chains with adjustable length.
- Always check the conditions of all equipment used and discard it if not in perfect working order.
- Do not knot or twist the ropes so as not to reduce the lifting capacity or produce torsional effects on the load being lifted.
- Exercise utmost caution and remain at a safe distance from lifted actuator unless absolutely necessary; do not stand or pass under suspended loads.
- Pay attention when putting the ropes under tension to prevent the load from shifting sideways in an uncontrolled manner.
- Use slings of such length that the angles of the leg from vertical are as narrow as possible ($\alpha_{MAX} < 45^\circ$).
- During handling, do not transport the suspended actuator above staff members in charge of the operation.

NOTE:

When α angle widens:

- The traction exerted on the respective ropes increases. It is thus necessary to use ropes with greater nominal load capacity.
- The working condition of the lugs is aggravated.

⚠ WARNING**Potential risk:**

Breaking of slings.

Elimination of the potential risk – Code of practice:

Always ascertain that the lifting capacity of the ropes used is adequate for the load and for the way it is harnessed. Amply underrate the working load limit, also in consideration of any wear condition of the equipment.

NOTE:

The weights indicated in Table 12 refer to the actuator only. The overall weight of the machine, inclusive of the actuator's accessories, is specified on the delivery note.

5.3 Actuator Handling

5.3.1 General Handling Provisions

Biffi Italia s.r.l. has provided purpose designed hooking (lugs and eyes) and lifting points on the actuator (Figure 17). For handling operations by means of overhead lifting equipment, a crane or similar means can be used. If the actuator is packed on a pallet, then a fork lift truck will have to be used.

⚠ WARNING**Code of practice:**

Strictly follow all handling procedures foreseen by Biffi Italia s.r.l., both with regard to the hooking points, and to the means to use. In any case, always comply with the health and safety regulations in force in the country of installation.

- Check the track in advance so as to identify any hindrance or obstacle (narrow or low passageways, ragged paving, clutter).
- Prevent suspended loads from swaying excessively and traverse at low speed.

⚠ WARNING**Code of practice:**

Assign a personnel to stay on the ground and assist the driver in case of insufficient visibility.

Section 6: Receipt and Installation of Actuator

6.1 Receipt and Inspection

Checks to be carried out upon receiving the actuator:



1. Check that the model, the serial number and technical data featured on the rating plate (refer to Section 3.2) are in accordance with those described on the order acknowledgement, delivery note or acceptance certificate.
2. Check that the fitted accessories comply with those listed in the order acknowledgement and the delivery note (refer to Section 3.2).
3. Upon arrival, the client must very carefully check the conditions of all the material received and report immediately any damage to the carrier. It is recommended to produce photographic evidence of any damage detected.



Contact as soon as possible Biffi Italia s.r.l. (refer to Section 2.1). If needed, restore varnishing according to the specifications featured in the order acknowledgement.

4. If the actuator arrives already assembled onto the valve, the settings have already been made.
5. If the actuator is delivered separately from the valve, please refer to Sections 6.2 to 6.4 below as regards installation and commissioning.

6.2 Storage

In the event that the actuator is not going to be installed straight away, it must be stored in a dry and airy place, preferably protected against direct sun light.

The surface where the actuator has to be stored must be clean, flat and suitable for the weight. Make sure it is stable and cannot fall off. Paper documents require special care.

NOTICE

Particular attention must be paid to the coupling surface with the valve, in order to prevent it from being damaged and preserve its characteristics.

In the event that the actuator has to be stored for a long period, the provisions below must be closely observed:

- Indoor storage in a sheltered environment:
 - Rest the actuator on a wooden surface, being careful not to damage the coupling surface with the valve.
 - Coat the coupling surface with oil, grease or protective disk to preserve its characteristics.
 - Make sure the plastic plugs are in place on both hydraulic and electrical ports (if fitted). In a sheltered environment, the plugs need not be water or weatherproof, as they are only meant to prevent debris from getting inside.
 - Check that the lids of electrical enclosures, if fitted, are properly closed.
 - Periodically operate the actuator.
- In the event that storage in a sheltered environment is not feasible: In addition to the above provisions, implement also those here below:
 - Make sure the actuator is protected against atmospheric agents (cover it with a tarpaulin).
 - Replace the plastic plugs for the hydraulic and electrical ports (if fitted) with water and weatherproof metal plugs.
 - Periodically operate the actuator.

6.3 Customer Duties

- Provision of installation site

NOTE:

The purchaser is responsible for equipping the installation premises in accordance with the health and safety regulations in force in their own country.

- Provision of lighting system
If the actuator is installed indoors, the room must be provided with proper lighting system, so as to prevent any hazardous conditions.

WARNING

Safe installation information:

The lighting of the premises where the actuator is installed must not create dark areas, strong, dazzling or stroboscopic effects.

6.4 Assembly Procedures

NOTE:

The procedures of this section refer to the vertical installation of the actuator. For the procedures referring to horizontal installation, please refer to the confirmation documentation.

6.4.1 Assembly

The actuator can be coupled to the valve via the coupling flange fitted with threaded bores.

Figure 20. Example of Coupling Flange



- With regard to the different coupling interfaces, please refer to 3.13.
- With regard to the bush insert or sleeve that can be used to connect the actuator output drive to the valve stem, please refer to Section 3.14.

NOTE:

With regard to the type of coupling interface fitted on the actuator, please refer to the documentation specified in the order acknowledgement.

- PPE to be used during installation procedures:



NOTICE

- Non-observance of the procedures described below will invalidate the product warranty.
- Installation, commissioning, maintenance and repair interventions must be performed by adequately skilled and trained personnel.
- Refer to the documentation relative to the order acknowledgement to ensure that installation is consistent with the plant.
- Refer to the documentation relative to the order acknowledgement to check consistency between actuator to valve interface and coupling elements.

⚠ WARNING

Assembly not performed in compliance with the provisions specified in the present document can:

- Give rise to severe accidents and cause damage to persons and property
- Affect the actuator's functional performance

NOTICE

Refer to the documentation relative to the order acknowledgement to check the actuator OP/CL (spring to open/close) function. Under this configuration, if the actuator is activated by means of a spring, a movement (and torque) is produced to make the valve stem rotate, respectively:

- Clockwise, to open the valve in OP configuration
- Counterclockwise, to close the valve in CL configuration

Depending on the actuator OP/CL configuration, set the valve stem and/or the actuator so that the direction of rotation generated by the actuator and its status are consistent with the position of the valve.

⚠ WARNING

Assembly not performed in compliance with the above provision can:

- Give rise to severe accidents and cause damage to persons and property
- Affect the actuator/valve functional performance

• Procedure

1. Refer to the instructions provided in Section 5 when handling and lifting the actuator for installation purposes.
2. Move the actuator so that, during assembly, it is in the same position as that of the valve.
3. To prepare the valve for actuator assembly, proceed as follows:
 - A. Lubricate the valve stem with oil or grease to facilitate assembly. Do not lubricate or apply grease to the flange.
 - B. Clean thoroughly and remove all traces of oil or grease from the coupling flanges of both actuator and valve.
4. If a valve extension or a fitting insert is being used, fix it in place using specific dowel screws.
5. Lift the actuator by using the provided lifting points (Section 5.2) ensuring the lifting equipment and slings are suitable for the weights to be lifted (Weights: Table 12).

6. Have ready to hand all the components required to perform correct coupling between:
 - A. Valve stem and actuator bush insert or sleeve, namely:
 - Keys and tabs
 - Threaded dowel screws
 - B. Valve-actuator coupling flanges
 - Dowel or locating pins, if required
 - Threaded fasteners (stud bolts, bolts and nuts)
7. Position the actuator vertically above the valve and lower it slowly so that the insert located on the valve stem can fit into the actuator coupling area. Do not force the actuator inside, but allow it to reach coupling by its own weight
8. Check that the bores on the two coupling flanges correspond. If they are not aligned, activate the stoppers (elements used to adjust the angular stroke - Section 7.2) to generate a rotation of the actuator and complete the coupling operation.
9. Tighten the actuator bolts to the valve. The tightening torques to be applied, in order to ensure proper coupling between valve and actuator, are specified in Table 20:

Table 20. Tightening Torques (Applicable for ASTM A320 L7 Screws and nuts in ASTM A194 Grade 7 s3)

Thread Size	Tightening Torque (Nm)
M8	20
M10	40
M12	70
M14	110
M16	160
M20	320
M22	420
M24	550
M27	800
M30	1100
M33	1400
M36	1700

NOTES:

If the fasteners are supplied by Biffi Italia s.r.l., the customer will receive:

- Stud bolts material: ASTM A320 L7
- Nuts material: ASTM A194 Grade 7 s3

NOTICE

Refer to the documentation relative to the order acknowledgment to check the materials of the threaded fasteners used to fix the actuator to the valve. If the fasteners are supplied by Biffi Italia s.r.l., apply the torques indicated in Table 20.

6.4.2 Pneumatic Connections

This IOM contains a description of the procedures to be observed in order to perform connection of pneumatic interfaces in the proper way. With regard to a correct functional connection, please refer to the relevant pneumatic diagram specified in the order acknowledgement.

- PPE to be used during installation procedures:



NOTICE

The steps described below must be carried out before proceeding to connect the actuator to the pneumatic line:

- Make sure the pneumatic line pressure rate corresponds to the value indicated on the actuator rating plate.
- Make sure the pipes and fittings of the pneumatic line are suitable for the job to be carried out (type, material and size).
- Make sure that, before reaching the actuator, the pressurized fluid is adequately filtered and cleaned from any solid residues.

⚠ WARNING

Operating the actuator at a pressure rate higher than the limit values specified on the rating plate (refer to Section 3.2) can:

- Give rise to severe accidents and cause damage to persons and property
- Affect the actuator functional performance

- Procedure:
 1. Accurately deburr the ends of rigid pipes, if fitted.
 2. Thoroughly clean the inside of pipes by blowing air or nitrogen through them.
 3. Shape and fasten the pipes in such a way as not to cause unusual stress at the mouthpiece or loosening of threaded connections.
 4. Carry out the connections according to the provided functional diagram (refer to Section 3.14).
 5. Check for leaks from the pneumatic connections.

6.4.3 Electrical Connections (If Foreseen)

Some actuators might need to be connected to the mains.

- PPE to be used during installation procedures:



NOTICE

The steps described below must be carried out before proceeding to connect the actuator to the electric line:

- Make sure the characteristics of the electrical power supply correspond to the indications given on the rating plates of electric components on the actuator, if fitted.
- Make sure the components used are suitable for the job to be carried out (type, material and size).
- Observe the safety provisions laid down in Standard CEI 64-8 (equivalent to IEC 60364).
- Read the technical documentation provided by the supplier, as regards electrical devices, if used.

⚠ WARNING

Before proceeding with any intervention, disconnect the power supply from the mains.

⚠ WARNING

Operating the actuator at a voltage rate higher than the limit values specified on the rating plate (refer to Section 3.2) may:

- Give rise to severe accidents and cause damage to persons and property
- Affect the actuator functional performance

- Procedure:

1. Remove the plastic plugs from the conduits.
2. Screw the cable glands to full extent.
3. Insert the wires for electrical terminals connection.
4. To ensure proper wiring, refer to the wiring diagram specified in the order acknowledgement.
5. Tighten the cable gland.
6. Replace the plastic plugs at the conduit mouthpiece with weatherproof metal plugs.

Section 7: Commissioning and Adjustments

7.1 Inspections Prior to Commissioning

NOTICE

- Make sure the pneumatic line pressure rate corresponds to the value indicated on the actuator rating plate.
- Make sure the mains supply voltage corresponds to the value indicated on the actuator rating plate.

⚠ WARNING

Operating the actuator at pressure or voltage rates higher than the limit values specified on the rating plate (refer to Section 3.2) can:

- Give rise to severe accidents and cause damage to persons and property
- Affect the actuator's functional performance

NOTICE

Make sure the environmental limits of the installation location correspond to the limit values specified on the actuator rating plate.



- Visually check for leaks on the various pneumatic connections present on the actuator (and in the control panel). If needed, redo the pneumatic connections (refer to Sections 3.15, 3.16 and 3.17).
- Visually check integrity of varnish coating. If needed, restore according to the specifications indicated in the order acknowledgement.

NOTICE

Ensure that the actuator can:

- Perform all the functions as provided by the pneumatic functional diagram.
- Transmit all the diagnostics signals (consistent with the wiring diagram) with regard to the different status conditions of the actuator during the performance of its various functions.

Please refer to the documentation relative to the order acknowledgement with regard to the pneumatic functional diagram and the wiring diagram.

⚠ WARNING

Using the actuator under partial operating conditions with respect to the provided functions, or if the diagnostics is not complete, can affect the functional performance of the plant where the actuator is integrated.

⚠ CAUTION

It is absolutely FORBIDDEN to commission the actuator prior to having performed all the inspections described above and under obvious faulty or potentially hazardous conditions.

7.2 Calibrating the Angular Stroke

- PPE to be used during installation procedures:



The angular stroke (0° to 90°) of the quarter-turn valve might need to be adjusted owing to misalignment between valve stem and actuator. In all TPS series models, the rotation angle of the output drive can be adjusted by changing by $\pm 5^\circ$ its end positions (OPEN or CLOSED) within the limit values of -5° to $+95^\circ$, by means of two mechanically adjustable end stoppers.

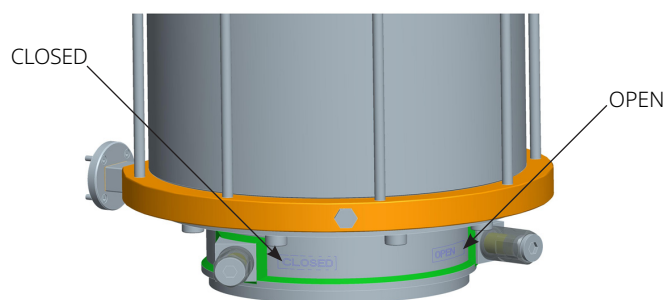
Both stoppers are located in the lower part of the actuator, protected by the head flange of the pneumatic cylinder.

NOTICE

The same design solution was implemented for the stoppers, which are exactly the same and both protected so as to prevent them from being polluted by polluting agents. Please refer to the documentation relative to the order acknowledgement with regard to overall dimensions and interface drawing, to clearly identify the stoppers position and make adjustments to the actuator open and closed positions, if needed.

The two stoppers provided on every TPS series actuator are identified by specific labels (as shown in Figure 21).

Figure 21. Stopper Operation



The function of the two stoppers is described below:

- Stopper CLOSED:
This adjustment allows changing the angular position of the output drive within the following range: -5° to $+5^{\circ}$, so that the output drive can be aligned with the valve stem when in CLOSED status.
- Stopper OPEN:
This adjustment allows changing the angular position of the output drive within the following range: $+85^{\circ}$ to $+95^{\circ}$, so that the output drive can be aligned with the valve stem when in OPEN status.

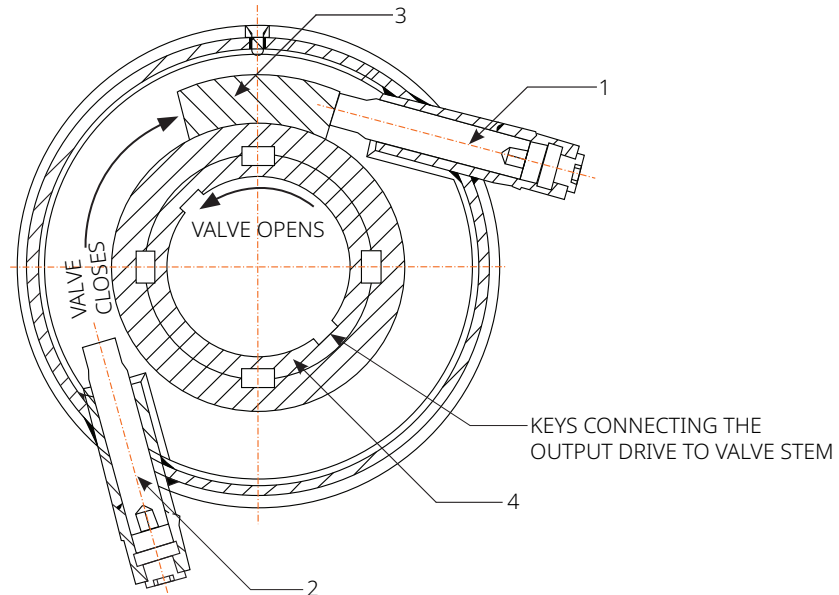
NOTICE

For every model of the TPS series, the position of the stoppers, used to adjust the angular stroke of the output drive, is the same for both OP and CL configurations.

For the sake of clarity, Figure 22 shows a plan view of a section of an actuator base, with the structural details of the stoppers and their operation.

Figure 22 also shows the structural detail of the groove orientation for the output drive keys.

Figure 22. Stopper Operation



In detail:

1. Stopper for CLOSED valve
2. Stopper for OPEN valve
3. Sector for adjustment
4. Output drive (lower part)

NOTE:

- The output drive is in closed position (refer also to Figures 8, 9 and 10).
- Direction of rotation of the valve when closing or opening.

Moving stopper 1 position forward or backward allows adjusting the angular position of the output drive when resting against the stopper in CLOSED status.

A similar operation can be performed on stopper 2 to adjust the angular position of the output drive in OPEN status.

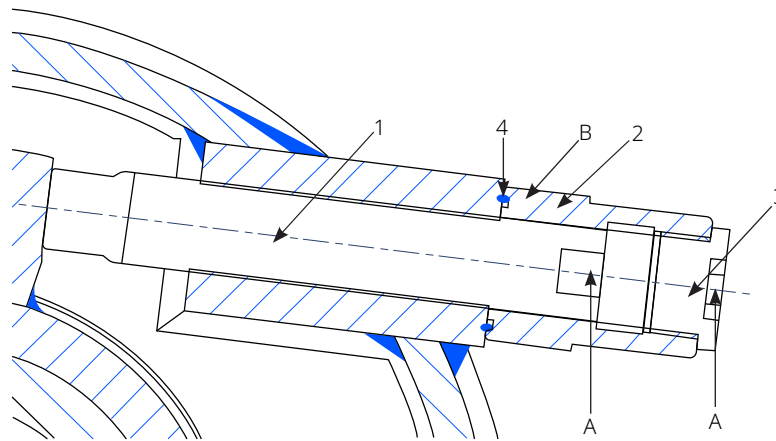
NOTE:

Figure 22 shows the two stoppers that are used to adjust the open/closed positions of the valve/actuator (output drive in actuator CLOSED status). Note that:

- In CL configuration, the actuator is maintained in the position shown in the figure by means of the spring. Consequently, the opening counterclockwise rotation is determined by pressurized air inside the pneumatic cylinder.
- In OP configuration, the actuator is maintained in the position shown in the figure by pressurization of inside the pneumatic cylinder. Consequently, the opening counterclockwise rotation is determined by the spring.

For the sake of clarity, Figure 23 shows the structural solution implemented for each stopper, the main components and the type of wrench to be used.

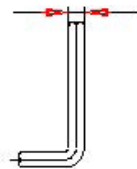
Figure 23. Stopper Components



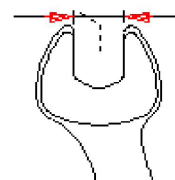
LEGENDS:

1. STOPPER
2. STOPPER GUARD
3. PLUG
4. O-RING

ALLEN KEY (TYPE A)



WRENCH (TYPE B)



1. Stopper
This consists of a right hand threaded dowel screw and is screwed inside the housing located on the base of the actuator. By using a type A Allen Key, the stopper can be moved forward or backward, to change the contact position with the adjustment sector and, consequently the extreme angular position of the output drive.
2. Stopper guard
This is screwed onto the stopper and can be moved by using a type B wrench. Its functions are:
 - To protect the stopper against direct contact with polluting agents, as it is fitted with a seal (4).
 - To keep the stopper in place by tightening it.
3. Plug
This prevents polluting agents from getting inside the stopper guard. By using a type A Allen Key, it can be removed so as to reach and move the stopper.
4. Seal
This prevents polluting agents from getting inside the stopper guard.

- Procedure:

NOTE:

The stoppers can be moved easily when the component identified as “adjustment sector” is not in contact with the stopper. If the actuator is operated by the spring or by the pressurized cylinder, it generates a torque that affects the stopper and prevents it from being moved.

With reference to Figure 23:

1. Remove the plug (3).
2. Loosen the stopper guard (2).
NOTE: when the stopper guard is being loosened, the seal (4) could come out of its housing.
3. Move the stopper (1) by right or left-hand rotation so as to displace forward or backward, depending on the type of adjustment required.
4. When the stopper required position is reached, put the seal (4) back in its housing located in the stopper guard (2).
5. Tighten the stopper guard (2) so as to lock the stopper (1) in place.
6. While performing the previous step, keep the stopper (1) steady by means of the specific wrench.
7. Put the plug (3) back in place.

Table 21 indicates the type of wrench needed to rotate the stopper (1), remove and tighten both the guard (2) and the plug (3):

Table 21. Wrench Sizes for Stopper Adjustment

Actuator Model	Stopper (1, Figure 23) Type A Allen Key	Guard (2, Figure 23) Type B Wrench	Plug (3, Figure 23) Type A Allen Key
TPS 0.A xxk - zzzz CL/OP	6	19	6
TPS 0.1 xxk - zzzz CL/OP	8	24	6
TPS 0.3 xxk - zzzz CL/OP	8	24	6
TPS 0.9 xxk - zzzz CL/OP	12	46	12
TPS 1.5 xxk - zzzz CL/OP	14	46	17
TPS 3 xxk - zzzz CL/OP	14	46	17
TPS 6 xxk - zzzz CL/OP	19	60	17
TPS 14 xxk - zzzz CL/OP	17	65	17
TPS 18 xxk - zzzz CL/OP	17	65	17
TPS 32 xxk - zzzz CL/OP	17	65	17

NOTE:

- With reference to Section 3.10, the alphanumeric sequences xxk and zzzz featured in the identification code of the actuator model, are not detailed, because the type of interface used for actuator to valve coupling depends NEITHER:
 - On the kinematic mechanism (xx = RP/SY) NOR on the type of spring (k = 1/2/3)
 - Nor on the type of cylinder (zzzz)
- The above data are valid for both Fail to Close (CL) and Fail to Open (OP) configurations for each actuator model.

Section 8: Biffi Limit Switch Box (If Fitted)

Biffi limit switch box, in its various configurations, is one of the devices that can be installed on TPS series actuator to indicate the position of the actuator.

This section can be applied and is valid only and exclusively if Biffi limit switch box is identified in the order acknowledgement as the position indicator device being used.

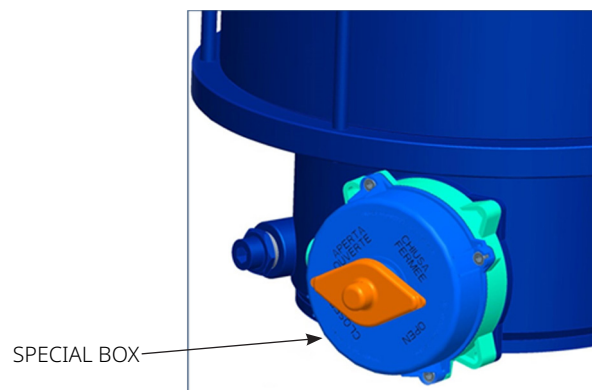
NOTE:

As a standard, the actuator is delivered with the valve position indicator device already installed (whichever it may be). Therefore, the scope of this section is not to provide a description for installing Biffi limit switch box on board the machine, but rather a description regarding the calibration of the limit switches housed inside the box.

8.1 Calibration of Biffi Limit Switches (If Fitted)

Microswitches are placed inside a special box, located at the base of the actuator, shown in Figure 24:

Figure 24. Stoppers: Position Adjustment



NOTICE

Operate only the microswitch corresponding to the direction of motion being carried out, as clearly indicated on the microswitch. Reference documentation: wiring diagrams.

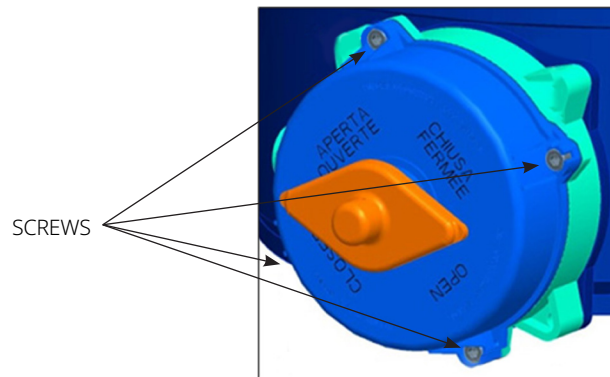
8.1.1 Limit Switch Calibration Procedure

- PPE to be used during installation procedures:



- Procedures
 1. Disconnect the power supply from the main supply.
 2. Unscrew the fastening screws on the cover, see Figure 25.
 3. Remove the cover cautiously.
 4. Locally move the actuator to open or closed status, accordingly.

Figure 25. Biffi Made Limit Switch Box



⚠ WARNING

Potential risk:

Damages to the seal and coupling surfaces.

5. Loosen the screw of the actuating cam associated to the microswitch and calibrate it accordingly. Refer to Figure 26.
6. Tighten the screw.
7. Operate the actuator and calibrate any other microswitch, using the same procedure described above.
8. Put the cover back in place, making sure the camshaft grips with the indicator drive shaft.
9. Ensure that the cover is properly oriented and the indicator is pointed to the correct valve status ("Open" or "Closed").
10. Tighten the screws on the cover.
11. Restore the power supply.

Figure 26. Cam Calibration



NOTICE

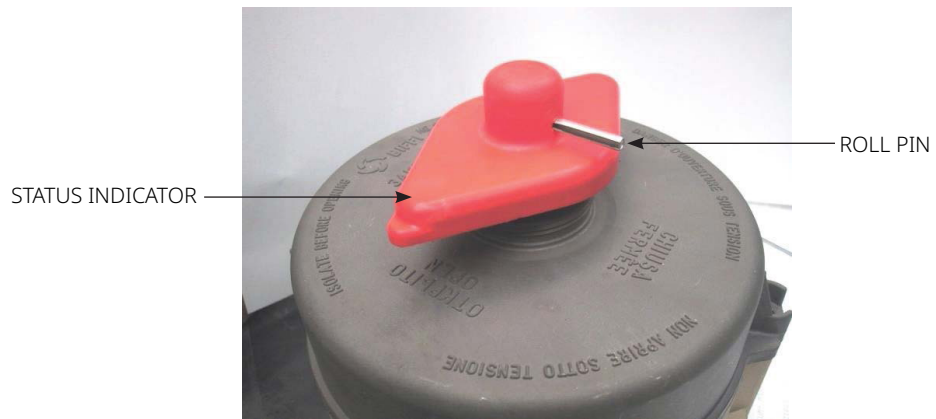
Limit switches should trigger before the actuator is halted by the stoppers at stroke end. Calibrate the associated cams accordingly.

8.1.2 Indicator Reset Procedure

If the indicator does not point to the correct valve status (“Open” or “Closed”), proceed as described below:

1. Remove the roll pin from the status indicator.
2. Slowly turn the indicator to the correct position.
3. Put the roll pin back in place.

Figure 27. Status Indicator and Roll Pin



Section 9: Routine Maintenance

TPS series actuators are designed to run without requiring maintenance for long periods under hard operating and environmental conditions (refer to Section 3.12) as well as in unmanned areas.


Despite that, owing to the great number of different conditions in terms of environment, operation and installation, it is however recommended, for this type of product, to perform routine maintenance interventions on a biannual basis, as described below.

NOTE:

With reference to Section 3.1, the instructions regarding maintenance apply to the actuator only and not to its accessories.

9.1 General Information

To ensure an optimal performance level of the machine, it is recommended to observe the procedures and schedules provided.

Assigned staff:	Qualified and authorized mechanical maintenance technician. Qualified and authorized electrical maintenance technician (only if electrical connections are fitted).
Number of staff:	2 maintenance technicians
PPE:	
Residual risks:	The main causes for potential serious damage to persons and property that could occur during maintenance are: accumulation of pressure inside the cylinder.
Eliminating the residual risk:	Strictly observe the procedures specified in this IOM and always proceed with extreme caution.

WARNING

Potential risk of harm to people and property

Before proceeding with any maintenance intervention, disconnect the pneumatic supply and release pressure from the cylinder via the control panel.




NOTE:

Overconfidence in maintenance procedures, resulting from the cyclic and recurrent repetition of the same actions, can lead to a relaxed behaviour towards maintenance interventions and a decreased attention span. Such attitude can also give rise to extremely serious and irreversible damage to persons and property. Therefore, it is highly recommended to proceed always with utmost care and, in case of doubt, refer to IOM or contact Biffi Italia s.r.l. After Sales Service.

9.2 Monitoring and Visual Inspection Activities

The interventions recommended to be performed every two years of running time, are listed in the table below:

Table 22. Maintenance Summary Table

Every 2 Years	
Type of Intervention	Description
	Check that valve is moved correctly by the actuator, with all the provided modes and declared motion times. If the actuator is used infrequently, it is good practice to perform some motions using all the provided controls (remote, local, emergency), if this activity is compatible with the plant conditions. During the motion, check, if possible, consistency in the diagnostic indication as regards to the status of actuator/valve. (Refer to the documentation relative to the order acknowledgement to check the type of actuator status indicator device installed).
	Check for pressure leaks in the pneumatic circuit.
	If the actuator is equipped with a desiccant filter for pneumatic air, check the drain pan for collection of condensate water and clean it regularly; filter maintenance is determined by the type of filter installed. To disassemble the filter, please refer to the supplier's documentation. With regard to the control panel components, refer to the documentation relative to the order acknowledgement and to the functional wiring and pneumatic diagrams.

9.3 Monitoring and Visual Inspection Activities for SIL Certification

To keep the SIL level at the initial level, is it mandatory, pursuant to the provisions of Standard IEC 61508, to check the actuator's smooth operation at regular intervals, as described below:

Table 23. Checks for SIL Certification

Check	Frequency
Perform: <ul style="list-style-type: none"> • A complete valve open/close motion, or • A partial valve open/close motion (if the actuator model is provided with such function) 	Annual
Perform the periodic maintenance interventions specified in Section 9.2.	Refer to Section 9.2

Section 10: Supplementary Maintenance

Supplementary maintenance interventions prescribed by Biffi Italia s.r.l. mainly regard replacement of non-metal material of the pneumatic cylinder, which can deteriorate and lose efficiency owing to the combined effect of:

- Aging (mainly dependent on the environmental conditions where it is used),
- Number of motions (dependent on the actuator application in the plant where it is integrated).

On the basis of the various different conditions in terms of environment, installation and operation under which TPS series actuators can be subject, for the purpose of ensuring machine optimum performance levels, Biffi Italia s.r.l. recommends that the supplementary maintenance interventions described in the present manual be executed:

- Biffi recommends carrying out maintenance checks and replacement activities (if necessary) every time the system is stopped for maintenance.

Unplanned supplementary maintenance intervention will be required when a decrease in efficiency is assessed as being due to the actuator and, in particular, to the seals.

NOTE:

Section 12 is a useful reference for identifying potential problems arising from poor maintenance.

NOTE:

The supervisor of the plant, where the TPS series actuator is installed, is responsible for:

- Verifying the feasibility of supplementary maintenance interventions described in this manual, on the premises where the actuator is installed or in a specialist workshop.
 - Verifying the need to disassemble the actuator from the valve (in that respect, refer to valve operating instructions).
 - Planning supplementary maintenance of TPS series actuators in line with the plant maintenance schedule, in order to ensure availability, within the required timing, of maintenance personnel and spare parts.
-

10.1 General Information About Supplementary Maintenance

Assigned staff:	Qualified mechanical maintenance technician. Qualified and authorized electrical maintenance technician (only if electrical connections are fitted).
Number of staff:	2 maintenance technicians
PPE:	

NOTE:

The supplementary maintenance interventions described below require the actuator to be disassembled and certain internal and external components to be handled.

WARNING

Potential risk of damage to persons and property:

In order to ensure its distinctive function, the product contains a spring constantly compressed. Strictly comply with the provisions specified in the present manual.

WARNING

Failure to observe the procedures and prohibitions specified in this manual can have serious consequences as regards the safety of persons and property.

Before proceeding with any of the supplementary maintenance interventions described in this manual:

NOTE:

Ensure that the plant infrastructures are consistent with the health and safety of staff in charge of maintenance and that:

- Space and equipment are adequate for components lifting and handling operations.
- Fixtures and hand tools can guarantee compliance with the dis/assembly provisions specified in this manual.
- No component, once disassembled, is at risk of falling by gravity, owing to installation conditions.



Refer to Tables 24, 25 and 26 in Section 10.3 for useful information as regards:

- Lifting and handling equipment for the components being disassembled.
- Space required for components disassembly and handling
- Fixtures and/or hand tools required for components (dis)assembly (even in those cases where installation conditions can cause components to fall if not adequately handled).

WARNING

When removing some components of the actuator, the spring for the return of the actuator to “fail-safe” status will be visible and accessible. Strictly comply with the provisions specified in this manual so as to avoid affecting the safety.

CAUTION

It is absolutely FORBIDDEN to remove the components retaining the spring.

NOTICE

In view of the complexity and residual risks mentioned in the present manual supplementary maintenance interventions can be performed exclusively by personnel provided by Biffi Italia s.r.l. or qualified on a training course provided by Biffi Italia s.r.l.



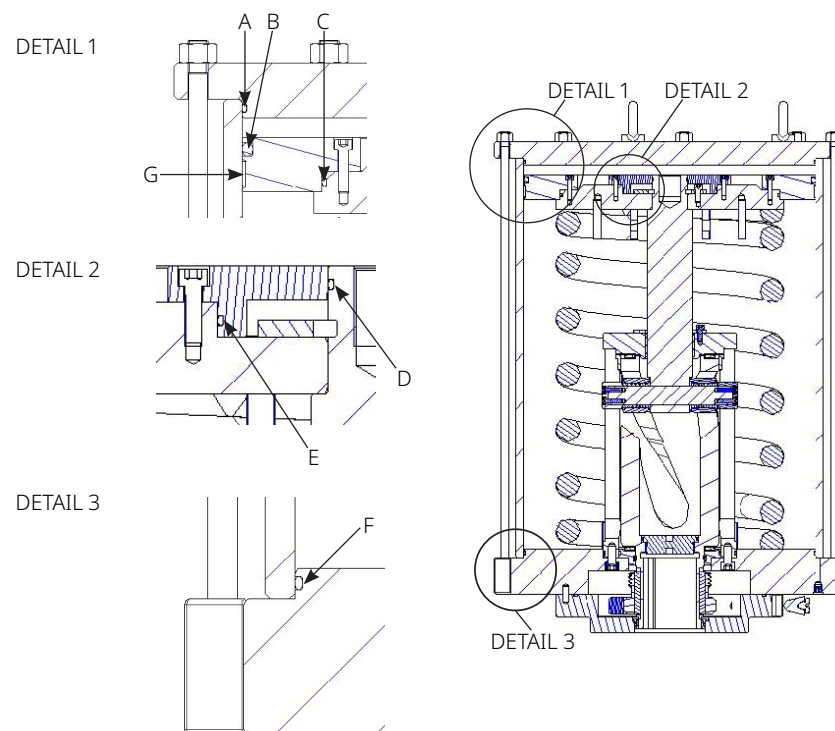
Contact Biffi Italia s.r.l. (refer to Section 2.1) for further information.

10.2 Technical Guidelines for Replacing the Pneumatic Cylinder Seals

10.2.1 General Description

Figure 28 shows a 2D section of a TPS series generic actuator model, with a detailed view of all the pneumatic cylinder seals, identified by alphanumeric indexing.

Figure 28. Pneumatic Cylinder Seals



Pneumatic Cylinder Seals Type for TPS Series Actuators

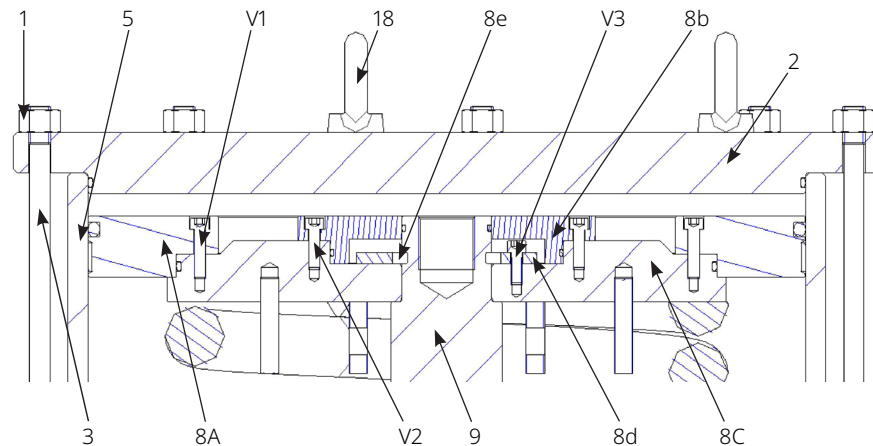
- A – End flange seal
- B – Piston outside seal
- C – Piston inside seal
- D – Plug inside seal
- E – plug outside seal
- F – Head flange seal
- G – Piston sliding ring



The codes for the pneumatic cylinder seals, for all TPS series actuator models, are listed in Tables 27 and 28.

Figure 29 shows a detailed 2D view of the main components, identified by numeric indexing, that have to be disassembled when replacing the pneumatic cylinder seals.

Figure 29. Pneumatic Cylinder Components



Components to be 'disassembled' when replacing pneumatic cylinder seals.

The components listed below can be identified by referring also to Figures 3, 4, 5 and 6:

1 - Tie rod nut	8c - Thrust flange
2 - End flange	8d - Safety ring
3 - Tie rod	8e - Retaining half rings
5 - Cylinder	9 - Stem
8a - Piston- ring assembly	18 - Lifting lug
8b - Piston plug assembly	V1, V2 and V3 - Screws

The piston assembly (8, Figures 3, 4, 5 and 6) shown in Figure 29 consists of components (identified with 8 plus a sequence of letters) having a specific function. In this way, all components of the piston assembly with seals and sliding ring (8a and 8b) can be disassembled without removing the spring; in fact, the spring stays compressed by means of the thrust flange (8c) and of the retaining system (8d and 8e).

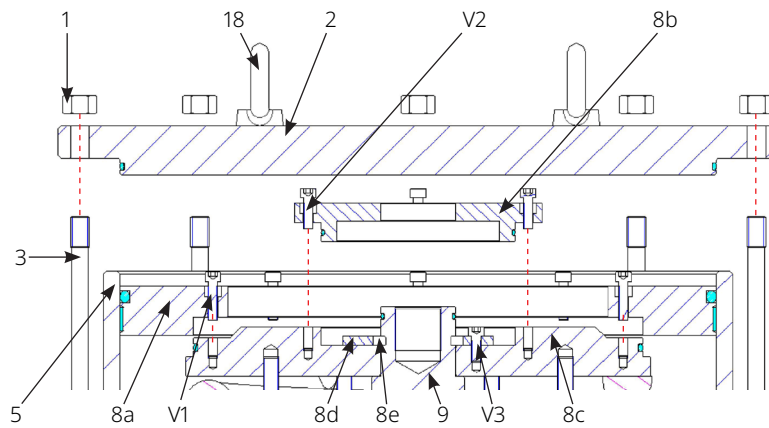
Figure 29 shows, in detail, the retaining system of the thrust flange (8c), which receives the thrust generated by the spring. The action of the spring is counteracted, respectively:

- By the retaining half rings (8e), inserted in their housing located in the stem (9).
- By the stem (9c) (which is in mesh with the kinematic mechanism). It is not the scope of this document to explain all the actions and reactions inside the kinematic mechanism that generate static operation. For present purposes it is sufficient to know that the thrust applied by the spring to the stem is counteracted by the kinematic mechanism.

Figure 29 features also the safety ring (8d), which keeps the retaining half rings (8e) in place inside their housing. The safety ring (8d) is fastened to the thrust flange (8c) by means of screws V3.

For the purpose of providing a graphical representation of the disassembly (and assembly) sequence, Figure 30, features a detailed 2D exploded view of the main components, identified by numerical indexing, that have to be disassembled when replacing the pneumatic cylinder seals. The dotted lines represent the flow lines that allow determining the disassembly sequences.

Figure 30. Pneumatic Cylinder Exploded View



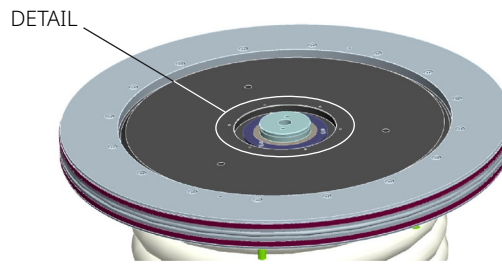
NOTE:

Figure 30 shows a crucial sequence relating to safety. The plug (8b) has to be disassembled in order to replace seals E and F (refer to Figure 28). In this way, the operator can gain access to the components of the retaining system of the thrust flange (8c).

Figures 31 and 32 and the close-up view of the detail, shows the position of the screws (V3) that fasten the safety ring (8d), which keeps the retaining half rings (8e) in place inside their housing on the stem (9).

NOTE:

The chamber where the two half rings (8e) are installed, is normally plugged (8b), refer to Figures 28 and 29.

Figure 31. Threaded Bores for Piston

The removal of the safety ring (8d), by unscrewing the screws (V3), is an operation carried out on a voluntary basis and **MUST NOT** be performed (but when the spring is to be disassembled), since it implies the removal of the retaining system of the two half rings (8e).

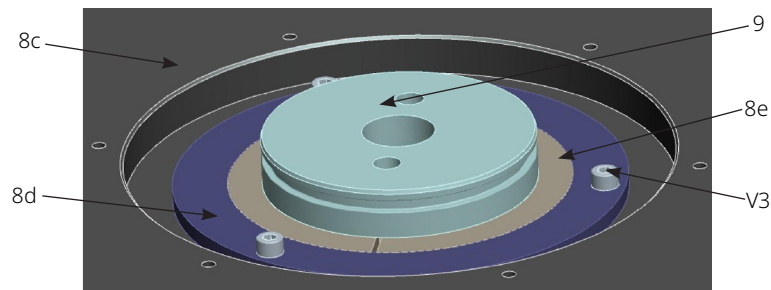
Figure 32. Retaining System of the Thrust Flange

Figure 33 shows in detail how the safety ring (8d) works and in what way it keeps the retaining half rings (8e) in place, preventing them from slipping out of their housing.

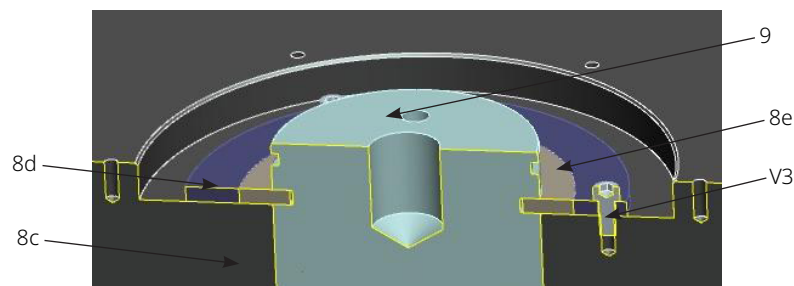
Figure 33. Retaining System of the Thrust Flange - Section View

Figure 34. Retaining System of the Thrust Flange - Detail of Half Rings Without Safety Ring

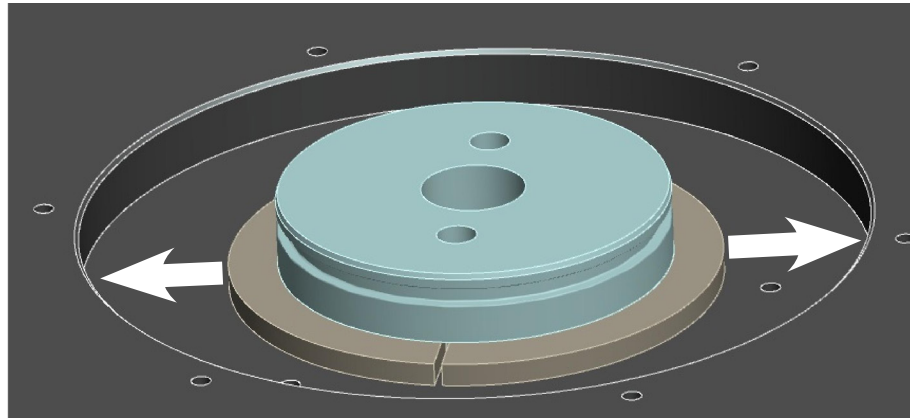


Figure 34 shows the retaining system of the thrust flange (8c) without the safety ring in place (8d) as well as the direction of movement, identified by the arrows, to make the two retaining half rings (8e) slip out of their housing.

⚠ WARNING

It is absolutely FORBIDDEN to disassemble the spring retaining system, which includes:

- The safety ring (8d)
- The retaining half rings (8e)
- The screws (V3) fastening the safety ring on the thrust flange (8c)

⚠ CAUTION

Danger of serious harm to people and property

The disassembly and removal of the safety ring (8d) involves the risk of the half rings (8e) being removed from their seats and consequently, the counteraction of spring thrust exerted by thrust flange (8c) would be nullified.

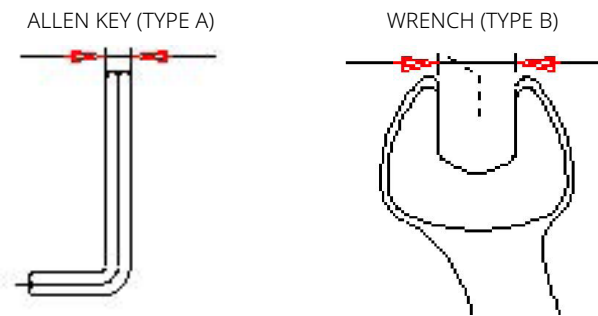
NOTICE

The pneumatic cylinder has to be disassembled in order to be able to replace the seals, and reassembled at the end of the operation. The procedure for such operations is illustrated in the following sections.

With reference to the description given in Section 10.2.1, the hand tools required for removing the threaded elements during dis/assembly operations of the pneumatic cylinder, are:

- Key (Type A): screws (V1, V2 and V3)
- Wrench (Type B): nuts (1)

Figure 35. Hand Tool Types for Pneumatic Cylinder Dis/assembly



10.2.2 Partial or Total Seal Replacement

Section 10.2.1, which is merely descriptive, allows having a general overview of the main steps associated with the replacement of the seal, in particular with regard to:

- Disassembly of the pneumatic cylinder.
- Handling of those components that required to be disassembled.

NOTE:

Refer to Section 10.3 for useful information regarding the size, weight, space required to handle the components being disassembled.

- Safety: when replacing the seals of the cylinder (Figure 30), the operator is obliged to gain access to the retaining system of the spring.

This section deals with the two different modes that can be used to replace the seals, namely total or partial.

NOTE:

The pneumatic cylinder (Figure 3, 4, 5 and 6) is separated by the piston into two different chambers. The lower chamber, in single-acting applications, houses the spring and is never pressurized; consequently, the head flange seal (F, Figure 28), besides being a static seal (meaning it is not subject to wear over time), also prevents polluting agents from getting inside the actuator (in TPS Series actuators).

In view of the information provided above and in Section 10.2.1, two different methods can be identified with regard to seal replacement:

Total Replacement: This method includes replacement of all the seals shown in Figure 28 including the head flange seal (F, Figure 28).

Partial Replacement: This method does not include replacement of the head flange seal (F, Figure 28).

The plant supervisor will decide whether to proceed with a total or with a partial replacement of the seals. However, Biffi Italia s.r.l. suggests to take into consideration the factors below:

- Visually check for air leaks near the head flange (4) and near the end flange (2).
- Check feasibility for a total seal replacement intervention on the basis of the operating modes described in Sections 10.2.3, 10.2.4 and 10.2.5 and on the information contained in Section 10.3.
- Check how long since the last total replacement of the cylinder seal and plan the actuator supplementary
- Maintenance interventions to be performed together with the plant maintenance schedule.

NOTE:

The sections below (refer to Sections 10.2.3, 10.2.4 and 10.2.5) contain a detailed description and the differences where applicable, of the procedures for:

- The total replacement of all the seals listed in Figure 28.
 - The partial replacement of all the seals listed in Figure 28 with the exception of the seal of the head flange (F, Figure 28).
-

10.2.3 Disassembling the Pneumatic Cylinder

NOTICE

Before proceeding with any operation, ensure that:

- The electrical power supply for the components on board the actuator is disconnected.
- The pneumatic supply for the actuator is disconnected.

NOTE:

The supplementary maintenance interventions described below require disassembly of all the accessories with which the actuator is equipped (control panel, valve status indicator device, manual override device, and sundry items).

Consequently, the pneumatic cylinder disassembly procedure refers to the components featured in Figures 28, 29 and 30, which represents the actuator status required at the start of the present procedure.

In this regard, refer to the documentation relative to the order acknowledgement.

NOTICE

Make sure to have received and have to hand all the documentation relative to all the components (actuator and accessories) that have to be disassembled and reassembled.

Strictly observe all the procedures and provisions indicated here below, so as to guarantee the safety of all staff members in charge of maintenance and the integrity of the actuator.

WARNING

Before proceeding with any maintenance intervention, disconnect the pneumatic supply and check that:

- Pressure has been released from the cylinder via the control panel and that there is no residual pressure inside the pneumatic cylinder.
- The actuator is in the status effected by the spring fail-safe function:
 - CLOSED in CL configuration
 - OPEN in OP configuration

10.2.3.1 Pneumatic Cylinder Disassembly Procedure for Seal Replacement

1. Move the fitting screwed to the pneumatic interface 1 (refer to Figures 11, 12 and 13) and used to supply the cylinder upper chamber.



Once the pneumatic fitting is removed, the pneumatic interface 1 (refer to Figures 11, 12, and 13) allows inspection of the upper chamber of the pneumatic cylinder. Under normal conditions, the kinematic mechanism is in the "fail-safe" status effected by the spring, characterized by the fact that the adjustment sector is resting against one of the two stoppers (refer to Sections 3.11 and 7.2). In that status, the piston never rests against the end flange, but there must always be a few millimetre gap.



A useful diagnostic indication of the actuator status is provided also by the device indicating the valve status (if it was considered appropriate not to disassemble it) or by the position of its interface shaft (refer to Figure 16).

WARNING

Risk of serious damage to persons and property

If the actuator is not in the fail-safe position effected by the spring, the kinematic mechanism is not at stroke end, but could be stopped in an intermediate position. Since the spring is constantly compressed, it could happen that, while the cylinder is being disassembled, the kinematic mechanism is suddenly released, in that way causing a violent movement of the spring.



In the event that the actuator is NOT in the fail-safe status effected by the spring, consult with Biffi Italia s.r.l. maintenance service.

2. Ensure the cylinder (5) has been locked into position by means of the specific fixture.

NOTICE

The fixture used must allow the cylinder (5) to stay locked in place even after removal of the nuts (1) and tie rods (3), without spoiling the outer varnish coating of the cylinder.

NOTE:

The cylinder (5, Figure 29) is constrained in its assembled position by both flanges (4 and 5), by the tie rods (3) and by the tie rod nuts (1). Since the cylinder disassembly operation requires the removal of nuts and tie rods, the cylinder is no longer locked. Biffi Italia s.r.l. can provide the specific fixture that allows the cylinder to stay locked, by keeping it in place, during disassembly and seal replacement (refer to Section 10.3).

3. Remove the tie rod nuts (1).
4. Remove the tie rods (3) Figures 3, 4, 5 and 6 or Figure 29.
5. Remove the end flange (2) from its housing in the cylinder (5), by means of the lugs (18).

NOTICE

The above operation must be performed with great care, so as to prevent spoiling the outer varnish coating. Restore any damaged varnish coating.

6. Remove the fixing screws (V1) of the piston – ring assembly (8a, Figure 29).
7. Lift and remove the piston – ring assembly (8a, Figure 29).
This operation is facilitated by the presence of threaded bores (Figure 36), which are not used to keep the component fastened, but can be used for:
 - Easier removal of the component by means of screws
 - Lifting purposes by inserting the lugs (Table 26).

Figure 36. Threaded Bores for Piston – Ring Assembly Extraction (8a)

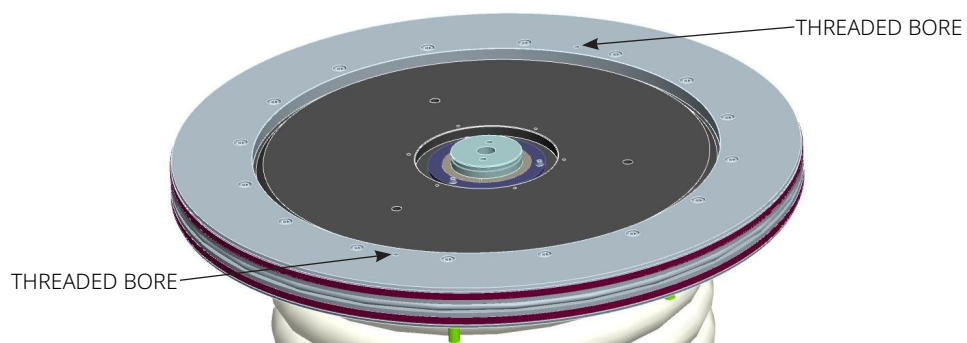
**NOTE:**

Figure 36 does not show the cylinder position.

8. Remove the fixing screws (V2, Figure 29) of the piston – plug assembly (8b, Figure 29)
9. Lift and remove the piston – plug assembly (8b, Figure 29).

NOTE:

The screws (V3, Figure 29) of the retaining system of the thrust flange (8c, Figure 29) will be accessible when the piston – plug assembly (8b, Figure 29) is removed; the flange is compressed by means of the spring.

CAUTION

It is absolutely FORBIDDEN to disassemble the spring retaining system, which includes:

- The safety ring (8d, Figure 29)
- The retaining half rings (8e, Figure 29)
- The screws (V3, Figure 28) fastening the safety ring on the thrust flange (8c, Figure 29)

⚠ WARNING**Risk of serious damage to persons and property.**

The removal of the screws (V3, Figure 29) affects the functional performance of the retaining system of the thrust flange (8c, Figure 29), which is compressed by means of the spring.

NOTE:

- In the case where it was decided to perform a partial replacement of the pneumatic cylinder seals (namely, to replace all the seals listed in Figure 28 with the exception of the head flange seal, refer to F, Figure 28), the pneumatic cylinder disassembly procedure is concluded here.
- In the case where it was decided to perform a total replacement of the pneumatic cylinder seals (namely, to replace all the seals listed in Figure 28), the pneumatic cylinder disassembly procedure continues, as described below.

10. Remove the cylinder (5) locking fixture from its position.
11. Lift the cylinder (5) and remove it from the actuator (refer to Table 26 as regards weights and the height to which the cylinder has to be lifted in order to pull it out of the kinematic mechanism).

NOTE:

The height required to pull the cylinder out is one of the main parameters to be considered when assessing the space needed to perform supplementary maintenance interventions on the premises or in a specialist workshop. As regards the weight, refer to Table 26.

NOTICE

The cylinder (5) is not provided with screw interfaces for handling purposes. Use padded clamps or jaws so as to prevent damaging:

- The treatment inner coating, applied to protect the cylinder against corrosion and to facilitate the piston sliding movement.
- The treatment outer coating, applied to protect the cylinder against corrosion.

⚠ WARNING

The compressed spring and the kinematism will be accessible when the cylinder (5) is removed. It is absolutely FORBIDDEN to put hand tools or other objects in the spring coils.

NOTE:

The spring will be visible and accessible when the cylinder (5, Figure 29) is removed. The removal of the cylinder, provided that the instructions of this manual are closely observed, does not affect the functional performance of the retaining system of the spring, which stays in position even if it is compressed and the elastic energy stored in it is considerable (according to the actuator dimensions).

10.2.4 Replacing the Seals

When the pneumatic cylinder is totally disassembled, all the seals can be replaced, namely on the cylinder and on the piston sliding ring (refer to Figure 28). The operations described below must be performed beforehand:

- A. Thoroughly clean the slots and housings of seals and sliding ring; lubricate with a thin film of grease.
- B. Put the seals and sliding ring accurately in place on the relevant component, being careful that the material does not get pinched or damaged.
- C. Grease and lubricate the seals in their housings and the sliding ring, so as to keep them in place during assembly.

NOTE:

As regards seal lubrication, Biffi Italia s.r.l. recommends this grease:
AGIP-ENI LCX 2/32 for Nitrile-Butadiene Rubber (NBR)/Viton/Neoprene seals;
Aeroshell Grease 7 for Fluorosilicon seals.

NOTE:

- In the case where it was decided to perform a partial replacement of the pneumatic cylinder seals, the head flange seal is excluded (F, Figure 28).
 - In the case where it was decided to perform a total replacement of the pneumatic cylinder seals, the first seal to replace is the head flange seal (F, Figure 28) so that the cylinder (5, Figure 29) can be reassembled. The flange must be inserted from above and put in place correctly by making it slide along the spring. The pneumatic cylinder disassembly procedure continues.
-

10.2.5 Assembling the Pneumatic Cylinder

The cylinder is reassembled by following in reverse order the sequence described in Section 10.2.3. A graphical representation of the assembly procedure description is featured in Figure 30. As regards the components associated with this operation, refer to Figure 28 and 29.

NOTE:

As regards the type of hand tools required to assemble the cylinder, refer to Figure 35. No specific tightening torque is prescribed for the screws (V1 and V2); nonetheless, the screws must be tightened properly. Use a sealant (LOCTITE® 510 or equivalent, recommended by Biffi Italia s.r.l.) to take preventive measures.

The tie rod nuts (1, Figure 29) serve a functional purpose for the structural integrity of the pneumatic cylinder. Consequently, a specific tightening torque (refer to Tables 24 and 25) is applied according to the tie rod type and material.

10.2.5.1 Pneumatic Cylinder Reassembly Procedure

1. Ensure that the seal (F, Figure 28) of the head flange (4, Figures 3, 4, 5 and 6) has been replaced and is properly seated in its housing.
2. Lift the cylinder (5, Figure 29) and put it back in place by performing the operations below:
 - A. Thoroughly clean the cylinder inner surface and ensure that neither the surface nor the mouthpieces are damaged.
 - B. Lubricate the entire inner surface and mouthpiece chamfers.
 - C. The cylinder must be lowered with great care, so as to prevent collision between the inner surface and the thrust flange (8c) or the spring.
 - D. The lower part of the cylinder should rest against the head flange (as shown in Figure 28). Consequently, be very careful not to damage the seal (F, Figure 28).
 - E. In the event that, during this maintenance operation, the actuator position can cause the cylinder to fall, when in place, a fixture suitable to lock the cylinder must be provided.

NOTICE

The cylinder (5) is not provided with screw interfaces for handling purposes. Use padded clamps or jaws so as to prevent damaging:

- The treatment inner coating, applied to protect the cylinder against corrosion and to facilitate the piston sliding movement.
- The treatment outer coating, applied to protect the cylinder against corrosion.

3. Ensure the cylinder (5, Figure 29) is locked in place by means of the specific fixture.

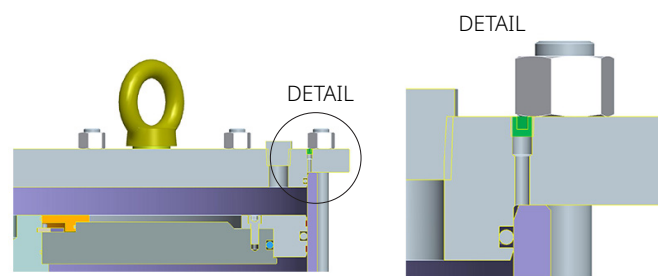
NOTE:

In the case where a partial replacement of the pneumatic cylinder seals has been performed, the pneumatic cylinder assembly procedure starts from the subsequent point.

4. Screw each tie rod (3, Figure 29) back in its housing on the head flange.
5. Ensure that the seals (D, E and Detail B, Figure 28) of the piston – plug assembly (8b, Figure 29) have been replaced and are properly seated in their housing.
6. Reassemble the piston – plug assembly (8b, Figure 29) and fix it in place by means of the screws (V2); proceed as follows:
 - A. Make sure the piston – plug assembly (8b) is properly centred in its housing on:
 - The head flange (8c, Figure 29)
 - The stem (9, Figure 29)
 - B. During assembly, be careful not to damage the seals (E and D, Figure 28).
7. Ensure that the seals (B and C, Figure 28) and the sliding ring (G and F, Figure 28) of the piston – ring assembly (8a, Figure 29) have been replaced and are properly seated in their housing.

8. Reassemble the piston – ring assembly (8a, Figure 29) and fix it in place by means of the screws (V1); proceed as follows:
 - A. Make sure the piston – ring assembly (8b, Figure 29) is properly centred in its housing on the head flange (8c)
 - B. During assembly, be careful not to damage the seals (B and C - as shown in Figure 28, Detail B)
 - C. Tighten the screws (V1, Figure 29)
 - D. Lubricate the upper side of the inner surface of the cylinder (5) after putting the piston – ring assembly back in place (8b, Figure 29).
9. Ensure that the seal (A, Detail A, Figure 28) of end flange (2, Figure 29).
10. Reassemble the end flange (2, Figure 29) and fix it in place by means of the tie rod nuts (1) in the following way:
 - A. Remove the threaded plug (or plugs) (Figure 36) from the end flange (2, Figure 29) so as to allow the seal to settle in place during assembly.

Figure 37. Threaded Plugs on End Flange (Item 2)



- B. When assembling the end flange (2, Figure 29), check the truing of the flange with the cylinder (5, Figure 29) and be careful not to damage the seal (A, refer to Detail A, Figure 28 Pneumatic cylinder seals for TPS series actuators). The end flange should rest against the cylinder.
- C. Tighten the nuts (1) on the tie rods (3) (Figures 29 and 30).

NOTICE

Tightening the tie rods and the nuts to the specific torque will guarantee the integrity of the pneumatic cylinder intended as pressure equipment. Refer to the documentation relative to the order acknowledgement with regard to the linkage material (1 and 3) and the type of thread and apply the tightening torques indicated in:

- Table 24 - Tightening torques – Tie rod material: ASTM A320 – L7.
Nut material: ASTM A 194 Grade 7 s3
- Table 25 - Tightening torques – Tie rod material: ASTM A320 B8M CL 2 -
Nut material: EN ISO3506-2 A4-80

CAUTION

Failure to observe the provisions above can:

- Affect the actuator performance.
- Cause serious consequences as regards the safety of persons and property.

10.3 Information Necessary for Seal Replacement

NOTE:

This section contains pieces of information that are necessary to perform maintenance operations under safe conditions. Such information might be obsolete as a result of amendments and upgrading subsequent to the release of the present document. Refer to the rating plate and to the documentation relative to the order acknowledgement to identify the type of actuator and accessories purchased and check the data with Biffi Italia s.r.l. After Sales Service.

Special Fixture

To lock the cylinder in place during disassembly operations, a special fixture is required, as already indicated in Sections 10.2.3 and 10.2.4. The characteristics of the fixture are:

- It can adapt to the outer cylinder without interfering with the tie rods.
- It can be fixed to the head flange.
- It consists of 2 or more jaws to grip the cylinder.
- The cylinder outer varnish coating is not spoiled by the grip.

Owing to the fact that TPS series actuators can be equipped with various different types of pneumatic cylinders (refer to Table 4), there are various types of fixtures available, to suit the cylinder in use.

NOTE:

Biffi Italia s.r.l. can provide the specific fixture to lock the cylinder.



Please contact Biffi Italia s.r.l. (Refer to Section 2.1) for further information.

Tightening Torque Tables

**Table 24. Tightening Torques – Tie Rod Material: ASTM A320 – L7
Nut Material: ASTM A 194 Grade 7 s3**

Tightening Torques (Standard Linkage)	
Thread	Tightening torque (Nm)
M8	-
M10x1.5	40
M12x1.75	70
M14	-
M16x2	160
M20x2.5	320
M22	-
M24x3	550
M27x3	800
M30	-
M33	-
M36	-

**Table 25. Tightening Torques – Tie Rod Material: ASTM A320 B8M CL 2
Nut Material: EN ISO3506-2 A4-80**

Tightening Torques (Standard Linkage)	
Thread	Tightening torque (Nm)
M8	-
M10x1.5	30
M12x1.75	58
M14	-
M16x2	130
M20x2.5	250
M22	-
M24x3	440
M27x3	535
M30	-
M33	-
M36	-

Table 26. Information Useful for Seal Replacement on Pneumatic Cylinder of TPS Series Actuators

Model	Cylinder (5, Figure 29)			Nut and Tie Rod Type (1, 3, Figure 29)	End Flange (2, Figure 29)	Piston - Ring (8a, Figure 29)		Piston - Plug (8b) Figure 29)	
	DN (mm)	Height (mm)	Weight (kg)	Thread	Weight (kg)	Weight (kg)	Lug Thread	Weight (kg)	Lug Thread
TPS0.A xxk 175 CL/OP	175	352	13	M12x1.755	9	1.3	-	4	-
TPS 0.1 xxk 235 CL/OP	235	440	25	M16x2	15	4	4 x M6	2	2 x M6
TPS 0.1 xxk 280 CL/OP	280	440	29	M12x1.75	20	5	4 x M6	2	2 x M6
TPS 0.3 xxk 280 CL/OP	280	525	35	M12x1.75	20	5	4 x M6	2	2 x M6
TPS 0.3 xxk 335 CL/OP	335	525	46	M12x1.75	30	8	4 x M6	2	2 x M6
TPS 0.3 xxk 385 CL/OP	385	525	55	M12x1.75	38	14	4 x M6	2	2 x M6
TPS 0.9 xxk 385 CL/OP	385	718	75	M12x1.75	37	14	4 x M6	4	2 x M6
TPS 0.9 xxk 435 CL/OP	435	718	88	M12x1.75	46	15	4 x M6	4	2 x M6
TPS 0.9 xxk 485 CL/OP	485	718	101	M16x2	63	16	4 x M6	4	2 x M6
TPS 1.5 xxk 485 CL/OP	485	820	115	M16x2	63	16	4 x M8	5	2 x M6
TPS 1.5 xxk 535 CL/OP	535	820	132	M16x2	80	23	4 x M8	5	2 x M6
TPS 1.5 xxk 585 CL/OP	585	820	148	M16x2	108	36	4 x M8	5	2 x M6
TPS 3 xxk 585 CL/OP	585	1035	187	M16x2	108	36	4 x M8	5	2 x M6
TPS 3 xxk 635 CL/OP	635	1035	249	M16x2	126	45	4 x M8	5	2 x M6
TPS 3 xxk 685 CL/OP	685	1035	259	M16x2	140	52	4 x M8	5	2 x M6
TPS 6 xxk 735 CL/OP	735	1347	373	M16x2	178	55	4 x M10	5	2 x M6
TPS 6 xxk 785 CL/OP	785	1347	398	M20x2.5	204	65	4 x M10	5	2 x M6
TPS 6 xxk 835 CL/OP	835	1347	423	M20x2.5	229	70	4 x M10	5	2 x M6
TPS 14 xxk 935 CL/OP	935	1670	586	M24x3	356	80	4 x M10	6	2 x M6
TPS 14 xxk 1000 CL/OP	1000	1670	586	M24x3	449	96	4 x M10	6	2 x M6
TPS 18 xxk 1000 CL/OP	1000	1900	713	M24x3	449	98	4 x M10	6	2 x M6
TPS 18 xxk 1100 CL/OP	1100	1900	942	M24x3	540	116	4 x M10	6	2 x M6
TPS 32 xxk 1200 CL/OP	1200	2185	1200	M24x3	650	122	4 x M10	6	2 x M6
TPS 32 xxk 1300 CL/OP	1300	2185	1280	M24x3	840	145	4 x M10	6	2 x M6

NOTE:

With reference to the ID code of the actuator model (Section 3.10), the data featured in this table depend neither on the type of kinematic mechanism (xx = RP/SY) nor on the type of spring (k = 1/2/3).

10.4 Lubrication Mechanism

Under normal operating conditions, TPS series actuators are lubricated for life.

In case the cylinder motions are extremely frequent, lubrication of the sliding and contact surfaces should be restored with grease.

The type of grease used and recommended by Biffi Italia s.r.l. for refilling and lubrication purposes at normal temperature is described below:

ENI MU/EP/2 *

To be used in standard temperature conditions: -30 to +85 °C

NLGI (National Lubricating Grease

Institute) consistency: 2

Worked penetration: 280 dmm

ASTM Dropping Point: 185 °C

Base oil viscosity at 40 °C: 160 mm²/s

ISO Classification: L-X-BCHB 2

DIN 51 825: KP2K - 20

Equivalent to: Use an equivalent or better product in compliance with the grease proposed in the actual scope of supply by Biffi Fiorenzuola. Your grease supplier can verify and propose an alternative product at your responsibility.

Mobilgrease 33 or Equivalent **

To be used in low temperature conditions: -60 to +100 °C

Notes:

* If the service is not special (i.e., oxygen, hydrogen or other mentioned during the offer stage).

** Use an equivalent or better product in compliance with the grease proposed in the actual scope of supply by Biffi Fiorenzuola. Your grease supplier can verify and propose an alternative product at your responsibility.

Section 11: Spare Parts

For information on requesting spare parts, please refer to Section 2.4.

Refer to Section 10.2 and Figure 28 for the spare parts that need to be replaced after supplementary maintenance interventions.

The information below contain the codes for the spare parts kits regarding:

- The actuator generic model
- The type of seal material

Each single part number of the kit indicated in the table below includes the following components:

Seals (Figure 28)	Type A, B, C, D, E and F
Sliding block	Type G

NOTE:

The data in the following tables refer to the product configuration updated to the revision date of the present manual. Please refer to the documentation relating to the order acknowledgement and to the drawings for detailed information on spare parts.

11.1 Pneumatic Cylinder Seals (Material: NBR)

Table 27. List of Seal Kits For Pneumatic Cylinder of TPS Series Actuators – NBR Material

Actuator Model		Spare Part Kit – Material: NBR (Refer to Figure 28)
TPD 0.A xxk 175	CL/OP	G0203P00AS0
TPS 0.1 xxk 235	CL/OP	G0203P01BS0
TPS 0.1 xxk 280	CL/OP	G0203P01CS0
TPS 0.3 xxk 280	CL/OP	G0203P03AS0
TPS 0.3 xxk 335	CL/OP	G0203P03BS0
TPS 0.3 xxk 385	CL/OP	G0203P03CS0
TPS 0.9 xxk 385	CL/OP	G0203P09AS0
TPS 0.9 xxk 435	CL/OP	G0203P09BS0
TPS 0.9 xxk 485	CL/OP	G0203P09CS0
TPS 1.5 xxk 485	CL/OP	G0203P15AS0
TPS 1.5 xxk 535	CL/OP	G0203P15BS0
TPS 1.5 xxk 585	CL/OP	G0203P15CS0
TPS 3 xxk 585	CL/OP	G0203P30AS0
TPS 3 xxk 635	CL/OP	G0203P30BS0
TPS 3 xxk 685	CL/OP	G0203P30CS0
TPS 6 xxk 735	CL/OP	G0203P60BS0
TPS 6 xxk 785	CL/OP	G0203P60CS0
TPS 6 xxk 835	CL/OP	G0203P60DS0
TPS 14 xxk 935	CL/OP	G0203PB14S0
TPS 14 xxk 1000	CL/OP	G0203PC14S0
PS 18 xxk 1000	CL/OP	G0203PB18S0
TPS 18 xxk 1100	CL/OP	G0203PC18S0
TPS 32 xxk 1200	CL/OP	G0203PC32S0
TPS 32 xxk 1300	CL/OP	G0203PD32S0

NOTES:

- With reference to Section 3.10, the alphanumeric xxk sequence, featured in the identification code of the actuator model, is not detailed. The seals depend NEITHER on the kinematic mechanism type (xx = RP/SY) NOR on the type of spring (k = 1/2/3).
- The above data are valid for both Fail to Close (CL) and Fail to Open (OP) configurations for each actuator model.

11.2 Pneumatic Cylinder Seals (Fluorosilicone material)

Table 28. List of Seal Kits For Pneumatic Cylinder of TPS Series Actuators – Fluorosilicone Material

Actuator Model		Spare Part Kit – Material: NBR (Refer to Figure 28)
TPS 0.A xxk 175	CL/OP	G0203P00AS1
TPS 0.1 xxk 235	CL/OP	G0203P01BS1
TPS 0.1 xxk 280	CL/OP	G0203P01CS1
TPS 0.3 xxk 280	CL/OP	G0203P03AS1
TPS 0.3 xxk 335	CL/OP	G0203P03BS1
TPS 0.3 xxk 385	CL/OP	G0203P03CS1
TPS 0.9 xxk 385	CL/OP	G0203P09AS1
TPS 0.9 xxk 435	CL/OP	G0203P09BS1
TPS 0.9 xxk 485	CL/OP	G0203P09CS1
TPS 1.5 xxk 485	CL/OP	G0203P15AS1
TPS 1.5 xxk 535	CL/OP	G0203P15BS1
TPS 1.5 xxk 585	CL/OP	G0203P15CS1
TPS 3 xxk 585	CL/OP	G0203P30AS1
TPS 3 xxk 635	CL/OP	G0203P30BS1
TPS 3 xxk 685	CL/OP	G0203P30CS1
TPS 6 xxk 735	CL/OP	G0203P60BS1
TPS 6 xxk 785	CL/OP	G0203P60CS1
TPS 6 xxk 835	CL/OP	G0203P60DS1
TPS 14 xxk 935	CL/OP	G0203PB14S1
TPS 14 xxk 1000	CL/OP	G0203PC14S1
TPS 18 xxk 1000	CL/OP	G0203PB18S1
TPS 18 xxk 1100	CL/OP	G0203PC18S1
TPS 32 xxk 1200	CL/OP	G0203PC32S1
TPS 32 xxk 1300	CL/OP	G0203PD32S1

NOTES:




- With reference to Section 3.10, the alphanumeric xxk sequence, featured in the identification code of the actuator model, is not detailed. The seals depend NEITHER on the kinematic mechanism type (xx = RP/SY) NOR on the type of spring (k = 1/2/3).
- The above data are valid for both Fail to Close (CL) and Fail to Open (OP) configurations for each actuator model.

Section 12: Troubleshooting

The indications provided in this section serve the purpose of facilitating the purchaser’s maintenance technicians in identifying the probable causes of shortcomings or failures that could be related to the TPS actuator.

This list has been drawn up on the basis of data processed by Biffi Italia s.r.l. after examining the failures or shortcomings occurred over the years on actuators already installed. Therefore, this list should not be considered complete and exhaustive, but rather a collection of the most frequent cases.

Table 29. Troubleshooting

Event	Possible Cause	Solution
Actuator not working	Electrical power supply failure (if electric/electronic components are fitted)	Check the status of the electrical power supply line and restore operation
	Pneumatic power supply failure	Check the status of the pneumatic power supply line and ensure that the on/off valve is open
	Valve stuck	Repair or replace
Actuator excessively slow	Control panel failure	 Contact Biffi Italia s.r.l. After Sales Service Phone, E-mail: Section 2.1
	Low supply pressure	Restore the correct rate: Section 3.12: Technical Data
	Worn out valve	Replace
Actuator excessively fast	High supply pressure	Restore the correct rate: Section 3.12: Technical Data
	Improper calibration of flow control valves	Perform a new calibration
Leakage in hydraulic circuits	Worn out or damaged seals	 Contact Biffi Italia s.r.l. After Sales Service Phone, E-mail: Section 2.1
	Improper stopper adjustment	Perform a new calibration
Incorrect valve position	Improper signalling from microswitches (if fitted)	Perform a new calibration
	Leakage in check valve of hydraulic control unit	 Contact Biffi Italia s.r.l. After Sales Service Phone, E-mail: Section 2.1

Section 13: Dismantling and Tear Down

Before starting the disassembly a large area should be created around the actuator so to allow any kind of movement without problems of further risks created by worksite.

WARNING

Before disassembling the actuator, it is necessary to close the pneumatic feed line and discharge pressure from the cylinder of the actuator from the control unit and from the accumulator tank, if present.

The opposition of pneumatic supply is discharged from the cylinder by the linear movement generated from the spring releasing. It moves the actuator and consequently the valve, in its fail-safe position.

If the actuator is still mounted onto the valve, loosen the threaded connections between valve and actuator (screws, tie rods, nuts)

Lift the actuator using the proper lifting points, see Section 5.2.

If the actuator needs storage before demolition, see Section 6.2.

NOTICE

The demolition of the actuator both concerning any electrical and mechanical part should be made by specialized staff.

Separate the parts composing the actuator according to their nature (e.g., metallic and plastic materials, fluids, etc.) and send them to differentiated waste collection sites, as provided by the laws and provisions in force.

This page is intentionally left blank

Biffi Italia s.r.l.
Strada Biffi 165
29017 Fiorenzuola d'Arda (PC)
Italy
T +39 0523 944 411

For complete list of sales and manufacturing sites, please visit
www.biffi.it or contact us at biffi_italia@biffi.it

FCIM-20167-EN © 2024 Biffi. All rights reserved.

The contents of this publication are presented for informational purposes only, and while every effort has been made to ensure their accuracy, they are not to be construed as warranties or guarantees, express or implied, regarding the products or services described herein or their use or applicability. All sales are governed by our terms and conditions, which are available upon request. We reserve the right to modify or improve the designs or specifications of such products at any time without notice.

