

Biffi GIG

Double-Acting Direct Gas Actuator

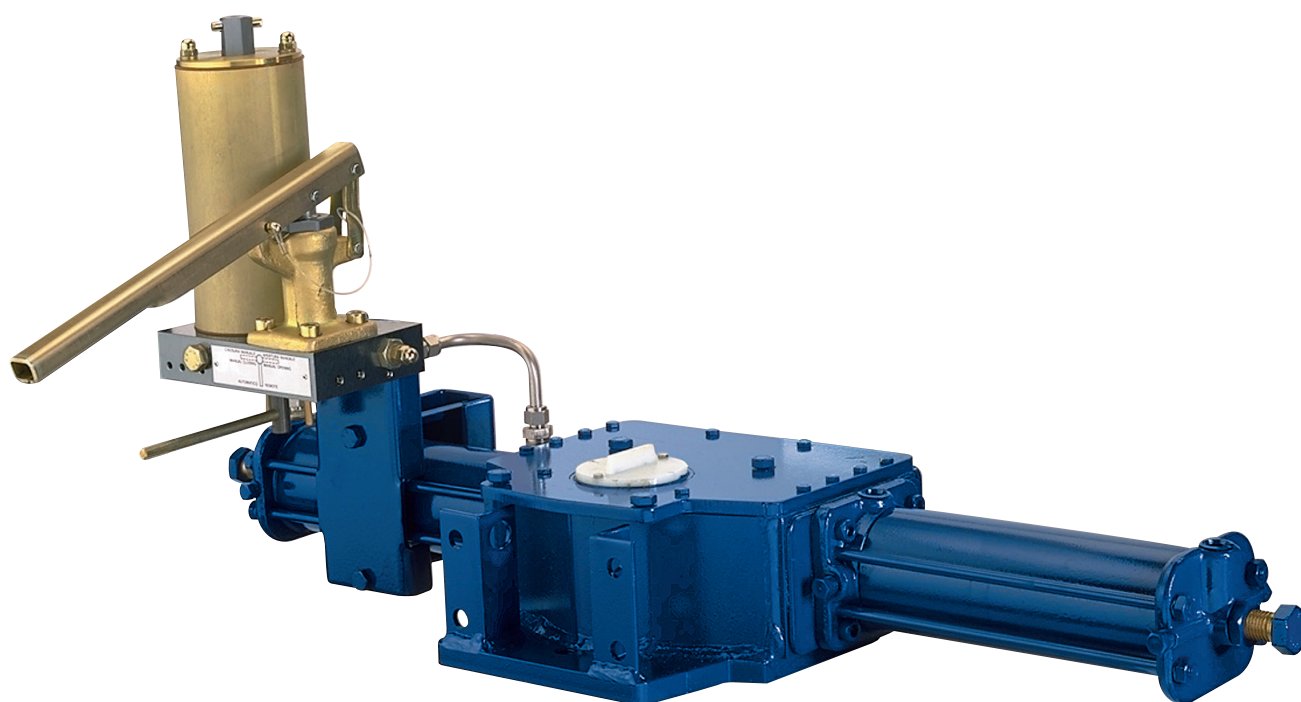

This page is intentionally left blank.

Table of Contents

Section 1: General Warnings

1.1	Generalities	1
1.1.1	Applicable Regulation	1
1.1.2	Terms and Conditions	2
1.1.3	Electrostatic Charge	2
1.1.4	Noise Emission	2
1.2	Identification Plate	3
1.3	Introducing the Actuator	4
1.4	Data Sheet	4

Section 2: Installation

2.1	Checks Upon Actuator Receipt	5
2.2	Actuator Handling	5
2.3	Storage	8
2.4	Actuator Assembly on the Valve	9
2.4.1	Types of Assembly	9
2.5	Assembly Procedure	17
2.6	Pneumatic Connections	18
2.7	Electrical Connections (If Any)	19
2.8	Commissioning	20

Section 3: Operation and Use

3.1	Operation Description	21
3.1.1	Typical Control Schematics	22
3.2	Residual Risks	25
3.3	Operations	25
3.3.1	Local Pneumatic Operation	25
3.3.2	Electric Remote Control to Open and to Close	26
3.3.3	Emergency Manual Operation by MSJ/MHW	26
3.3.4	Emergency Manual Operation by MHP	28
3.4	Calibration of the Angular Stroke	31
3.5	Calibration of Microswitches (If Foreseen)	36
3.6	Calibration of the Operation Time	37

Section 4: Operational Tests and Inspections

	Operational Tests and Inspections	39
--	---	----

Section 5: Maintenance

5.1	Periodic Maintenance	40
5.1.1	Check and Restore Oil Level in the Hydraulic Manual Override	41
5.2	Extraordinary Maintenance	44
5.2.1	Replacement of Cylinder Seals	44
5.3	Dismantling and Demolition	48
5.4	Lubrication of Mechanism	49

Section 6: Troubleshooting

6.1	Failure or Breakdown Research.....	50
-----	------------------------------------	----

Section 7: Spare Parts

7.1	Spare Parts Order	51
7.2	Parts List for Maintenance and Replacement Procedure.....	52

Section 8: Date Report for Maintenance Operations

	Date Report for Maintenance Operation.....	60
--	--	----

NOTICE

Biffi™ pays the highest attention to collecting and verifying the documentation contained in this Installation, Operation and Maintenance (IOM) manual. However, Biffi is not liable for any mistakes contained in this manual, for damage or accidents due to the use of the latter. The information contained is of exclusive reserved ownership of Biffi and may be modified without prior notice. All rights reserved.

Section 1: General Warnings

NOTICE

The manual is an integral part of the machine, it should be carefully read before carrying out any operation and it should be kept for future references.

1.1 Generalities

Biffi actuators are conceived, manufactured and controlled according to the Quality Control System in compliance with EN-ISO 9001 international regulation.

1.1.1 Applicable Regulation

EN ISO 12100:2010:	Safety of machinery – General principles for design – Risk assessment and risk reduction
2006/42/EC:	Machine directive
2014/68/EU:	Directive for pressure PED equipment
2014/35/EU:	Directive for low voltage equipment
2014/30/EU:	Directive for the electromagnetic compatibility
2014/34/EU:	Directive and safety instructions for use in hazardous area

For EAC Certification

EN ISO 12100:2010:	Safety of machinery – General principles for design – Risk assessment and risk reduction
TR TS 004/2011	Customs Union Technical Regulation (For safety of low voltage equipment)
TR TS 010/2011	Customs Union Technical Regulation (For safety of equipment and machines)
TR TS 012/2011	Customs Union Technical Regulation (For safety of equipment operated in explosive atmosphere)
TR TS 020/2011	Customs Union Technical Regulation (Electromagnetic Compatibility of Technical Products)
TR TS 032/2013	Customs Union Technical Regulation (For safety of Excess Pressure Equipment)

1.1.2 Terms and Conditions

Biffi guarantees that all the items produced are free of defects in workmanship and manufacturing materials and meet relevant current specifications, provided they are installed, used and serviced according to the instructions contained in the present manual. The warranty can last either one year from the date of installation by the initial user of the product, or eighteen months from the date of shipment to the initial user, depending on which event occurs first. All detailed warranty conditions are specified in the documentation forwarded together with the product. This warranty does not cover special products or components not warranted by subcontractors, or materials that were used or installed improperly or were modified or repaired by unauthorized staff. In the event that a fault condition be caused by improper installation, maintenance or use, or by irregular working conditions, the repairs will be charged according to applicable fees.

The warranty and Biffi's liability shall lapse in the event that any modification or tampering whatsoever be performed on the actuator.

1.1.3 Electrostatic Charge

An electrostatic charge risk is present on the actuator surface; in case of cleaning, use only antistatic cloth; in case of maintenance, avoid all rubbing/frictions that could electrostatically charge the equipment.

1.1.4 Noise Emission

The verification of the noise of the actuated valve is at valve maker care. The actuator's noise can be considered negligible since it is an equipment for regular on/off or intermittent use. If the integral quick exhaust valve is present, we recommend using ear Personal Protective Equipment (PPE) to avoid any possible acoustic discomfort.

Figure 1. Ear PPE



1.2 Identification Plate

⚠ WARNING

It is forbidden to modify the information and the marks without previous written authorization by Biffi.

The plate fastened on the actuator contains the following information (Figures 2 and 3).

Figure 2. GIG Nameplate (Sample)







		Manufacturer: BIFFI ITALIA Strada Biffi, 165 29017 Fiorenzuola D'ARDA (PC) - ITALY	
Order _____			
ACTUATOR	Model _____		
	S/N _____	MM/YYYY _____	
	TAG N° _____	ND _____	
Supply Press.Range _____		MOP _____	
Amb.Temp. _____			
CYLINDER	FI.Type _____	FI.Group _____	PED Cat. _____
	TS _____	Test Date _____	
	PS _____	PT _____	Cyl.Weight _____
		Ref.: _____	WARNING: Potential Electrostatic Charging Hazard See Instructions

Figure 3. GIG-EAC Nameplate (Sample)

			Certificate of Conformity
Order _____			
ACTUATOR	Model _____		
	S/N _____	MM/YYYY _____	
	TAG N° _____	ND _____	
Supply Press.Range _____		MOP _____	
Amb.Temp. _____			_____
CYLINDER	FI.Type _____	FI.Group _____	PED Cat. _____
	TS _____	Test Date _____	
	PS _____	PT _____	Cyl.Weight _____
		Ref.: _____	WARNING: Potential Electrostatic Charging Hazard See Instructions

1.3 Introducing the Actuator

The direct gas actuator GIG was engineered and is manufactured to provide fail safe operation for any quarter turn application such as ball, plug, butterfly valves or dampers, in both on/off and modulating heavy duty service.

The actuator (see Figure 4) is made up of a weatherproof scotch yoke mechanism transforming the linear movement of the pneumatic cylinder (on closing or opening) into the rotary movement, which is necessary for operation. The angular stroke of the yoke is adjustable between 82° and 98° by means of the external mechanical stops screwed into the left wall of the mechanism housing and into the end flange of the pneumatic cylinder. The cover of the scotch yoke mechanism is arranged for the assembly of the required accessories (positioner, signalling limit switches, position transducer, etc.) by means of proper matching units. The above mentioned accessories are operated by the actuator drive sleeve. The housing of the scotch yoke mechanism has a flange with threaded holes to fix the actuator to the valve either directly or, if required, with the interposition of an adaptor flange or a mounting bracket. The actuator yoke has a hole with keyways suitable for the assembly of an insert bush the internal hole of which is machined (by Biffi or at customer's care), according to the shape and dimensions of the valve stem. Biffi can supply different types of control system following customer's requirements.

The expected lifetime of actuator is approximately 25 years.

Figure 4. Identification of Actuator Parts

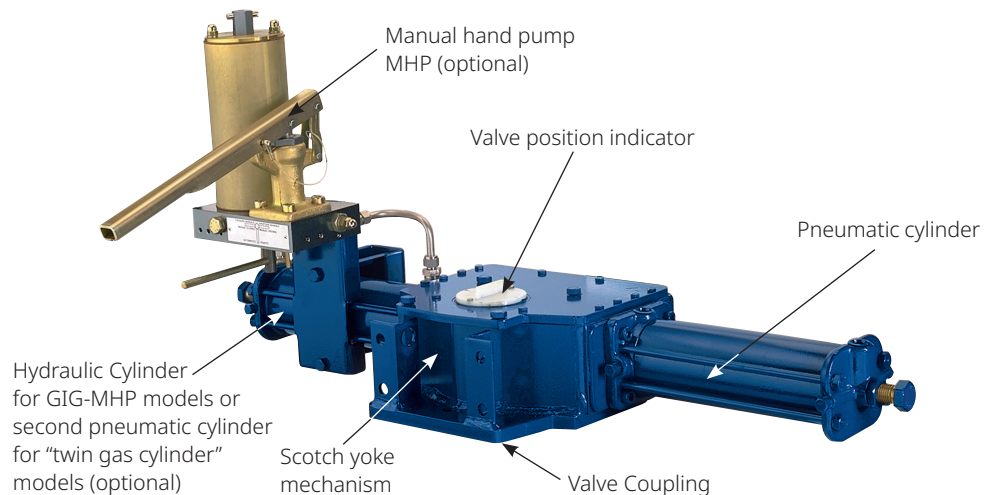

1.4 Data Sheet

Supply fluid	Sweet, dry natural gas; sour high-pressure gas; nitrogen or instrument air.
Operating temperature	Standard: from -20 to 100 °C Optional: from -60 to 140 °C
Supply pressure	Please refer to technical document: "actuator data sheet"

Section 2: Installation

2.1 Checks Upon Actuator Receipt

- Check that the model, the serial number of the actuator and the technical data reported on the identification plate correspond with those of order confirmation, see Section 1.2.
- Check if the actuator is equipped with the fittings as provided for by order confirmation.
- Check if the actuator was not damaged during transportation. If necessary, renovate the painting according to the specification reported on the order confirmation.
- If the actuator is received already assembled with the valve, its settings have already been made at the factory.
- If the actuator is delivered separately from the valve, it is necessary to check, and if required, to adjust the settings of the mechanical stops (Section 3.4) and of microswitches (if any) (Section 3.5).

2.2 Actuator Handling

NOTICE

The lifting and handling of the actuator must be done by qualified personnel and in accordance with the laws and regulations in force. Avoid hanging the lifted actuator above any personnel.

⚠ WARNING

The actuator must be lifted by means of a suitable lifting apparatus. The weight of the actuators is indicated in the technical documentation attached to the equipment itself. When lifting and moving the actuator, use only hooks fitted with a safety latch, like the one shown in Figure 5.

Figure 5. Example of Hook with Safety Latch



Figure 6. Lifting Points for GIG/GIG-MHP/GIG-MSJ/GIG-MHW Actuators

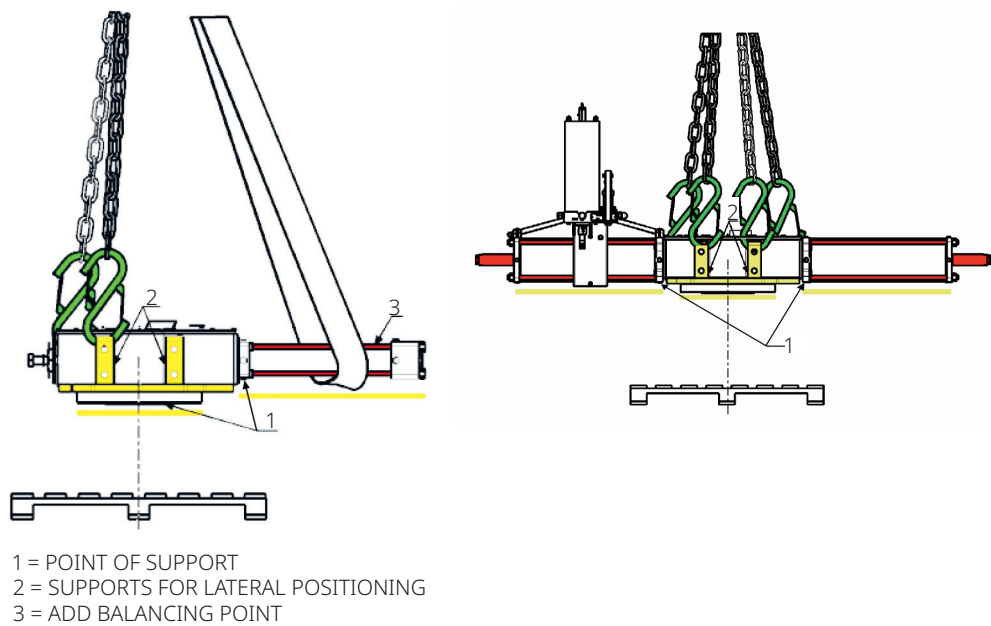
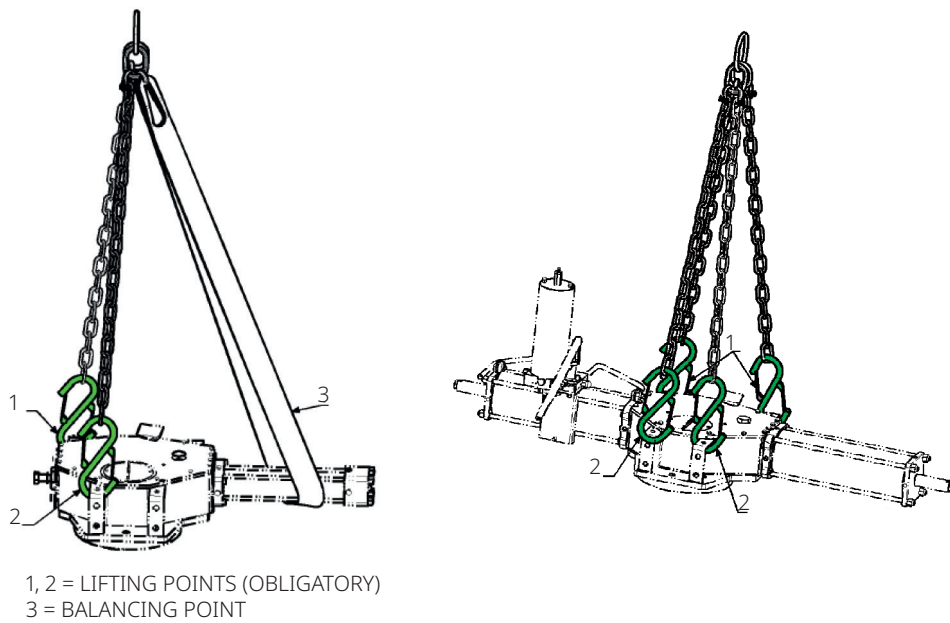

⚠ WARNING

Point 3 is a balancing point. Do not lay the actuator on tie rods of cylinder/s and do not lay the actuator on accessories (manual hand pump, manual jackscrew, pneumatic control group etc.).

- When lifting unbalanced loads, use ropes of different lengths or chains with adjustable length.
- Always check the condition of all lifting equipment used and discard it if not in perfect working order.
- Do not knot or twist the ropes so as not to reduce the lifting capacity or produce torsional effects on the load being lifted.
- Exercise utmost caution and remain at a safe distance from lifted actuator unless absolutely necessary; do not stand or pass under suspended loads.
- Pay attention when putting the ropes under tension to prevent the load from shifting sideways in an uncontrolled manner.
- Use slings of such length that the angles of the leg from vertical are as narrow as possible ($\alpha_{MAX} < 20^\circ$).
- During handling, do not transport the suspended actuator above staff members in charge of the operation.

WARNING

Do not use the lifting eyelets on the actuator to lift the valve + actuator assembly.

Figure 7. Lifting Warning Label

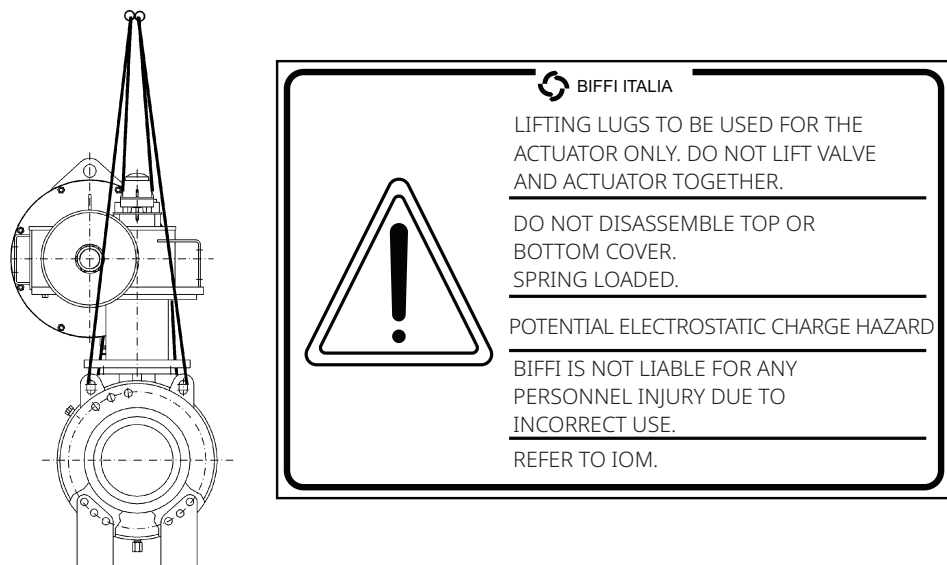

2.3 Storage

⚠ WARNING

The actuators should remain in their cases until required for installation.

⚠ CAUTION

Pay attention to use the proper tool to open the case and the tool inside.

For handling and lifting procedure, please refer to Figure 6.

⚠ WARNING

The actuator mounting bracket is to support the actuator only. Under no circumstances should the valve be suspended from the actuator.

⚠ CAUTION

Before testing or cycling be sure to remove all the appropriate port plugs. Storage time is counted as part of the service interval.

The actuators leave the factory in excellent working conditions and with an excellent finish (these conditions are guaranteed by an individual inspection certificate); in order to maintain these characteristics until the actuator is installed on the plant, it is necessary to observe a few rules and take appropriate measures during the storage period.

1. Make sure that plugs are fitted in the oil connections and in the cable entries. The plastic plugs, which close the inlets, do not have a weatherproof function, but are only a means of protection against the entry of foreign matter during transport. If long-term storage is necessary and especially if the storage is outdoors, metal plugs must replace the plastic protection plugs, which guarantee a complete weatherproof protection. Make sure that all seals are not exposed to very high or very low temperatures and gas for a prolonged period of time.
2. If the actuators are supplied separately from the valves, they must be placed onto a wooden pallet so as not to damage the coupling flange to the valve. In case of long-term storage, the coupling parts (flange, drive sleeve, insert bush) must be coated with protective oil or grease. If possible, blank off the flange by a protection disk. In cases where actuators are not to be cycled during extended dormant conditions, slight seal leakage may occur during start-up. If this occurs, multiple cycling will flex the seals and significantly improve the seal function. If leakage persists, installation of new seals may be required.
3. In case of long-term storage (>1 year), it is advisable to keep the actuators in a dry place or to provide at least some means of weather protection. If possible, it is also advisable to periodically operate the actuator with the proper oils listed in the IOM or selected/approved at time of order or nitrogen with 99% purity; after such operations all the threaded connections of the actuator and the valves of the control panel (if existing) should be carefully plugged.

2.4 Actuator Assembly on the Valve

2.4.1 Types of Assembly

For coupling to the valve, the housing is provided with a flange with threaded holes according to Biffi base tables (SCN6200; SCN6200-1; SCN6201; SCN62011; SCN62013; SCN62015). The number, dimensions and diameter of the holes are made in accordance with ISO 5211, but for actuator models 0.3 to 6, the holes are drilled on the centerline in order to allow an easier assembly of an intermediate flange, when required. This intermediate flange (or spool-piece) can be supplied when the valve flange cannot directly match the actuator flange in its "base" configuration. For the biggest actuator models, the actuator flange can be machined in accordance with the valve flange dimensions.

The yoke is bored with keyways for coupling to the valve stem, the dimensions of which are according to Biffi base tables SCN2600 and SCN2601 (Tables 1 to 6).

Figure 8. Coupling Dimensions - Actuator Model 0.3 to 6 (SCN6200 - Rev. 15/10/19)

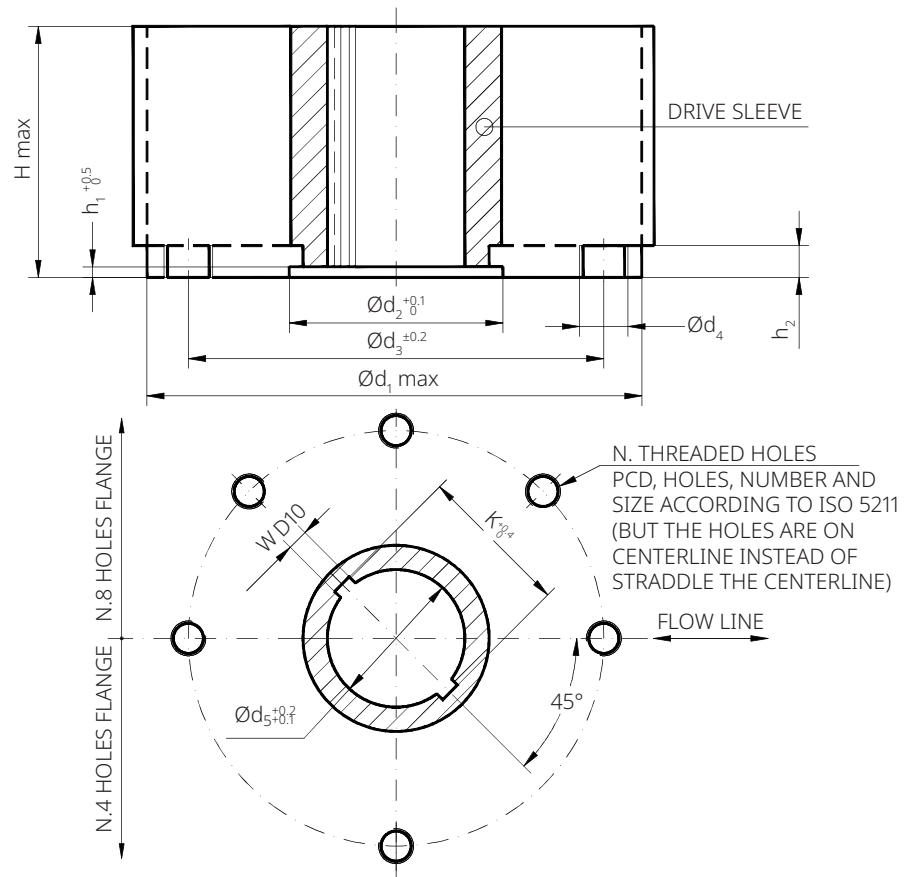

TOP VIEW OF THE SCOTCH YOKE MECHANISM (ACTUATOR SHOWN IN CLOSED POSITION)

Table 1. SCN6200-1 - Rev. 15/10/19

Actuator Model	Ød ₁	Ød ₂	Ød ₃	Ød ₄	N	h ₁	h ₂	H max	Ød ₅	W	K
0.3	240	93	165	M20	4	5	17	127	70	12	75.6
0.9	310	112	254	M16	8	5	19	150	86	14	96.6
1.5	360	144	298	M20	8	6	19	190	112	18	119.0
3	430	195	356	M30	8	9	23	200	157	25	167.8
6	520	250	406	M36	8	14	29	260	200	28	212.8

NOTE:
All dimensions are in millimeters.

Figure 9. Coupling Dimensions - Actuator Model 14 (SCN6201 - Rev. 16/06/20)

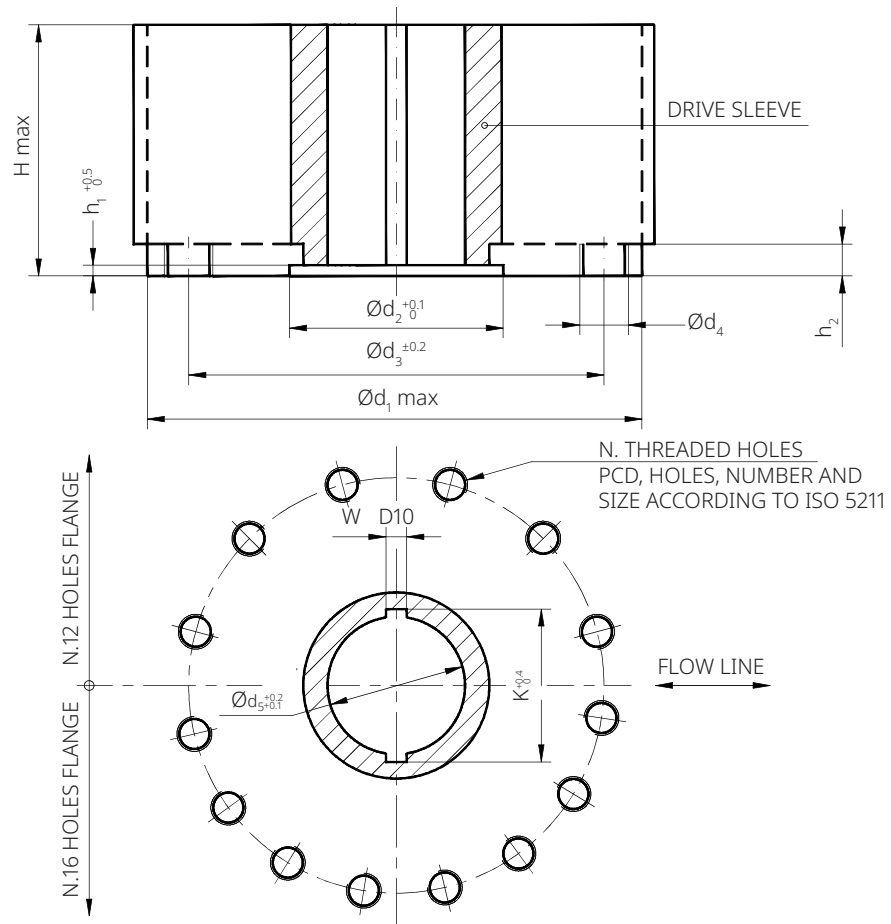

TOP VIEW OF THE SCOTCH YOKE MECHANISM (ACTUATOR SHOWN IN CLOSED POSITION)

Table 2. SCN6201 - Rev. 16/06/20

Actuator Model	Ød ₁	Ød ₂	Ød ₃	Ød ₄	N	h ₁	h ₂	H max	Ød ₅	W	K
14	580	250	483	M36	12	10	29	340	170	45	195.8

NOTE:
All dimensions are in millimeters.

Figure 10. Coupling Dimensions - Actuator Models 18 and 32 (SCN6201 - Rev. 16/06/20)

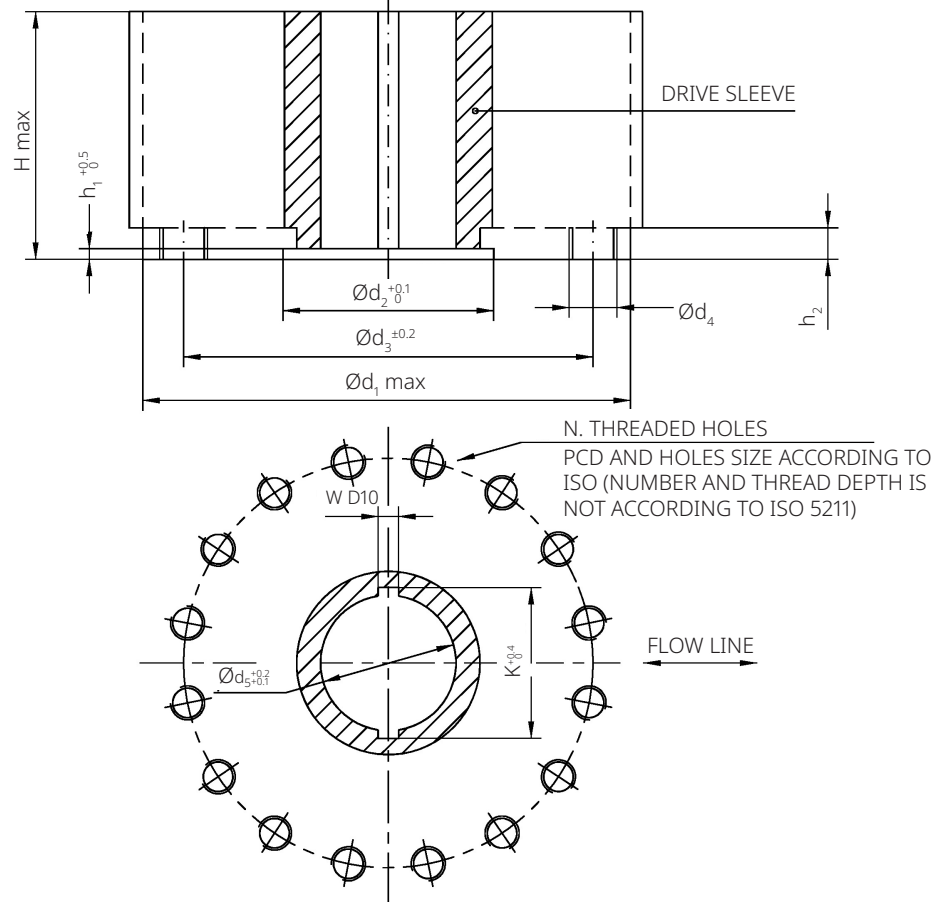

TOP VIEW OF THE SCOTCH YOKE MECHANISM (ACTUATOR SHOWN IN CLOSED POSITION)

Table 3. SCN6201 - Rev. 16/06/20

Actuator Model	Ød ₁	Ød ₂	Ød ₃	Ød ₄	N	h ₁	h ₂	H max	Ød ₅	W	K
18	680	290	603	M36	16	12	32	350	200	45	220.8
32	780	310	603	M36	16	12	32	400	220	50	242.8

NOTE:

All dimensions are in millimeters.

Figure 11. Coupling Dimensions - Actuator Model 50 (SCN62011 - Rev. 15/10/19)

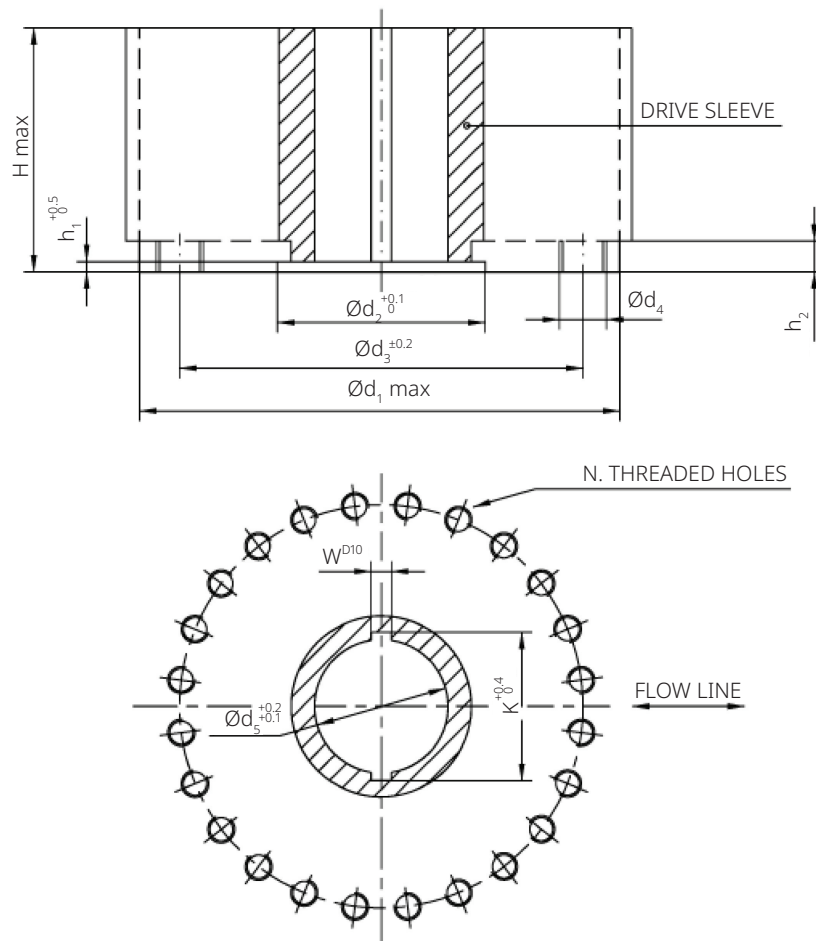

TOP VIEW OF THE SCOTCH YOKE MECHANISM (ACTUATOR SHOWN IN CLOSED POSITION)

Table 4. SCN62011 - Rev. 15/10/19

Actuator Model	Ød ₁	Ød ₂	Ød ₃	Ød ₄	N	h ₁	h ₂	H max	Ød ₅	W	K
50	800	315	698	M36	24	10	32	430	240	56	264.8

NOTE:
All dimensions are in millimeters.

Figure 12. Coupling Dimensions - Actuator Models 65 and 80 (SCN62013 - Rev. 19/06/20)

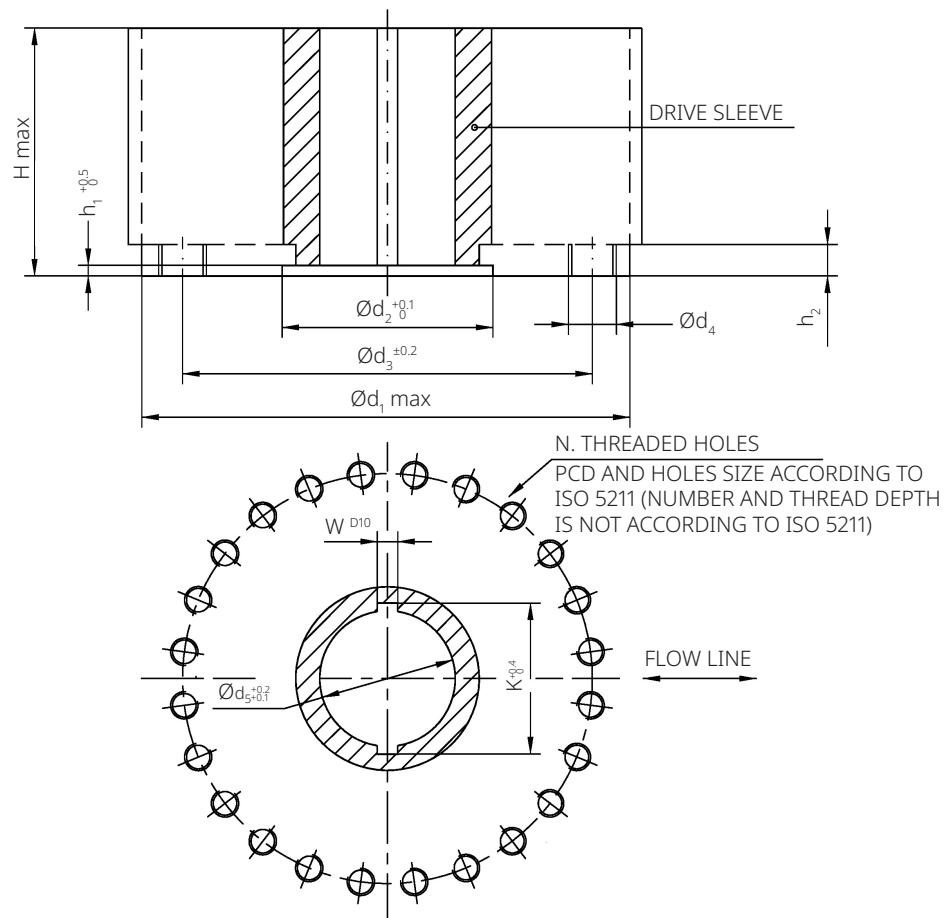

TOP VIEW OF THE SCOTCH YOKE MECHANISM (ACTUATOR SHOWN IN CLOSED POSITION)

Table 5. SCN62013 - Rev. 19/06/20

Actuator Model	Ød ₁	Ød ₂	Ød ₃	Ød ₄	N	h ₁	h ₂	H max	Ød ₅	W	K
65	910	370	813	M42	24	12	37	540	280	46	327.4
80	900	970	813	M42	24	12	37	540	280	46	327.4

NOTE:
All dimensions are in millimeters.

Figure 13. Coupling Dimensions - Actuator Model 100 (SCN62015 - Rev. 22/07/22)

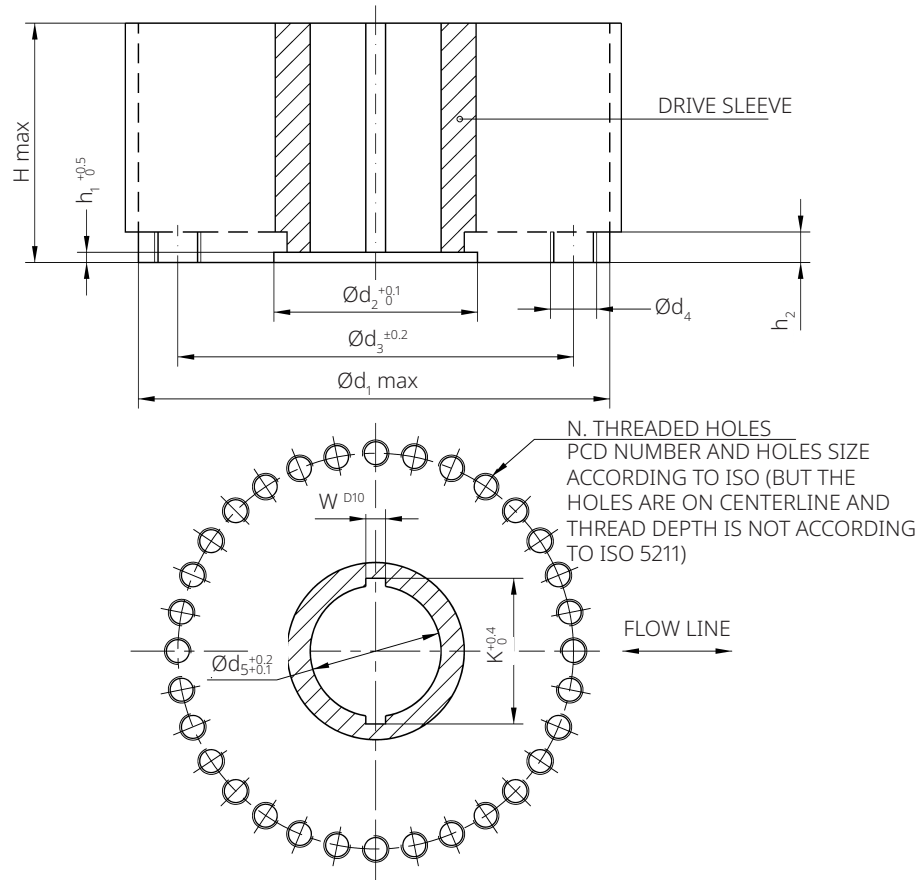

TOP VIEW OF THE SCOTCH YOKE MECHANISM (ACTUATOR SHOWN IN CLOSED POSITION)

Table 6. SCN62015 - Rev. 22/07/22

Actuator Model	Ød ₁	Ød ₂	Ød ₃	Ød ₄	N	h ₁	h ₂	H max	Ød ₅	W	K
100	1200	450	1042	M42	32	8	57	600	300	70	328.8

NOTE:
All dimensions are in millimeters.

If required, for the standard models size 0.3 to 6, Biffi can supply an insert bush with an unmachined bore in accordance with Biffi standard table SCN6202. On request, the insert bush bore can be machined by Biffi to couple the valve stem, provided its dimensions match the maximum stem acceptance of the bush according to Figure 14. The particular execution of the flange and bushing allow the actuator to be rotated by 90° in 4 different positions according to Figure 14.

Figure 14. Insert Bush + Intermediate Coupling Flange

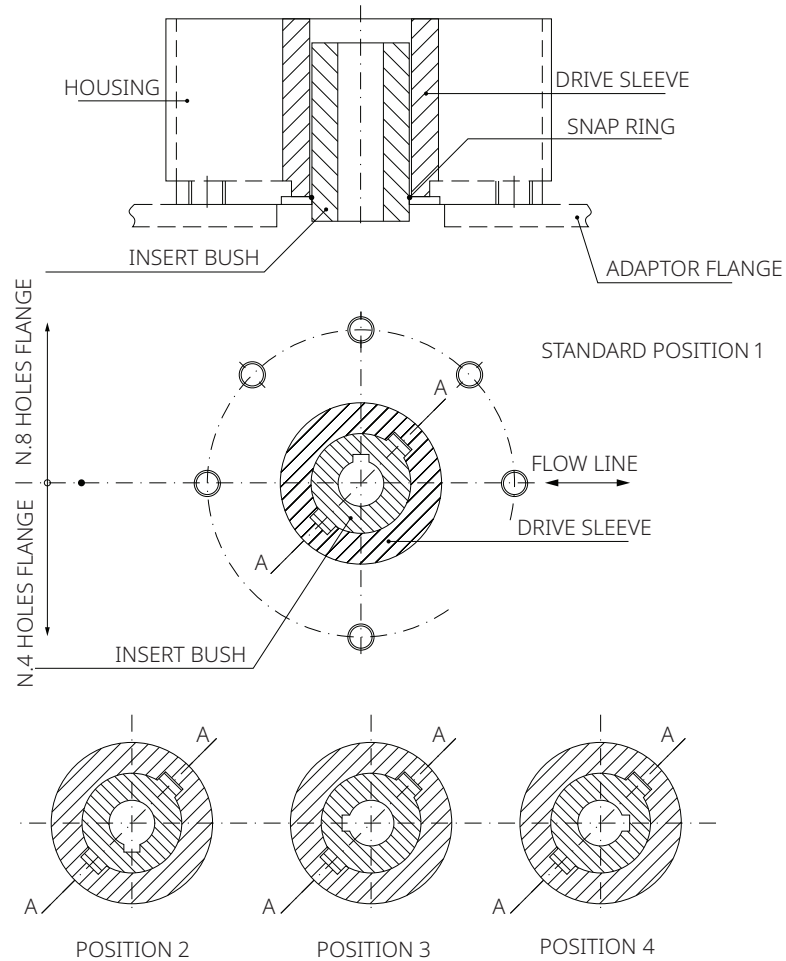

Table 7. Insert Bush Position

Position 2	Position 3	Position 4
Rotate insert-bush 180° around vertical-standard position 1	Rotate insert-bush 180° around axis A-A, from position 2	Rotate insert-bush 180° around axis A-A from position 1
Insert bush turned upside down		

The Biffi insert bush with 2 external keys at 45° allows to position the keyway for the valve every 90°. Consequently, the actuator can be mounted in 4 positions at 90° on top of the valve. For biggest actuator models, the bore of the yoke can be machined according to the dimensions of valve stem.

2.5 Assembly Procedure

NOTICE

Failure to comply with the following procedures may impair product warranty.

WARNING

Installation, commissioning and maintenance, and repair works should be carried out by qualified staff. A non-conforming assembly could be the source of serious accidents.

For actuator assembly on the valve:

NOTICE

Check that the assembly position, as shown on the documentation, complies with system's geometry. Check the consistency of the parts of actuator-valve coupling.

- Operate the actuator so that it reaches the matching valve position (Section 3.3).
- Lubricate the valve stem with oil or grease.
- Properly clean and remove grease from valve coupling flange surfaces.
- Connect, if supplied separately, the adjustment insert to the valve stem and fasten it with the special fastening pins.
- Lift the actuator using the special lifting points (Section 2.2).
- Install the actuator so that valve stem inserts in the coupling area. This coupling should be made without forcing.
- Fasten the two parts with the threaded connections (screws, tie rods, nuts). If the holes of coupling flanges are not aligned, operate the actuator as necessary to move the mechanical stops backwards (Section 3.4).
- Fasten threaded connections. Please refer to Table 8.

Table 8. Nuts Tightening Torque

Threading	Tightening Torque (N·m)
M8	20
M10	40
M12	70
M14	110
M16	160
M20	320
M22	420
M24	550
M27	800
M30	1100
M33	1400
M36	1700

The screwing values in Table 8 were calculated considering the materials ASTM A320 Grade L7 for screws or tie rods and ASTM A194 Grade 2H for the nuts.

2.6 Pneumatic Connections

WARNING

Check if the values of hydraulic supply available are compatible with those reported on the identification plate of the actuator.

NOTICE

The connections should be made by qualified staff. Use pipes, fittings and connections appropriate per type, material and dimensions.

- Properly deburr the ends of rigid pipes.
- Properly clean the interior of pipes by sending plenty of the supply fluid used in the system through them.
- Mould and fasten the connection pipes so that no irregular strains at entries or loosening of threaded connections occur.
- Make the connections according to the operating diagram.
- Check the pneumatic connections for leakage.

NOTICE

If it is necessary to mount components not in Biffi's scope of supply, please check the accessory's mounting hole details in the documents TN 1028 (for metric dimension) or TN 1028U (for imperial dimension).

2.7 Electrical Connections (If Any)

⚠ WARNING

Use components appropriate per type, material and dimensions. The connections should be made by qualified staff. Before carrying out any operation, cut line power off.

Safety provisions:

2006/95/EC:	Directive for low voltage equipment (until 19 April 2016) 2014/35/EU from 20 April 2016
2004/108/EC:	Directive for the electromagnetic compatibility (until 19 April 2016) 2014/30/EU from 20 April 2016
94/9/CE:	Directive and safety instructions for use in hazardous area (until 19 April 2016) 2014/34/EU from 20 April 2016

Remove plastic plugs from cables entries:

- Screw firmly the cable glands.
- Introduce connection cables.
- Make the connections in compliance with applicable wiring diagrams on the documentation supplied.
- Screw the cable gland.
- Replace the plastic plugs of unused entries with metal plugs.

Figure 15. Junction Box on Control Group (if Foreseen)



2.8 Commissioning

WARNING

Check to see if the values of electrical supply to the control group (if foreseen) are compatible with those on the plate on the junction box (Figure 15). Installation, commissioning and maintenance and repair works should be made by qualified staff.

Upon actuator commissioning, please carry out the following checks:

- Check that the paint was not damaged during transport. If necessary, repair the damage to the paint coating.
- Check if the pressure and quality of the gas supply (filtering degree, dehydration) are as prescribed. Make sure that the feed voltage values of the electric components (solenoid valve coils, microswitches, pressure switches, etc.) are compatible with those reported on the identification plate of the actuator (Figures 2 and 3).
- Ensure that the setting of the components of the actuator control unit (pressure regulator, pressure switches, flow control valves, etc.) meet the plant requirements.
- Conduct all kinds of operations, and check if they were properly executed (Section 3.3).
- Check the pneumatic connections for leakage. If necessary, tighten the nuts of the pipe fittings.
- Check proper operation of all the due signalling (valve position, gas supply pressure, etc.)
- Make a complete functional test in order to verify that all the operations are executed according to the operating schematic diagram supplied.

Section 3: Operation and Use

3.1 Operation Description

In the normal operating situation, the direct gas actuator is fed by pressurised gas which flows into the relevant cylinder chamber (for example opening). The cylinder piston stroke causes the actuator operation and the consequent valve movement to the operational position requested (in this case to the “open” position).

Upon a demand, the closing chamber the cylinder is fed by pressurised gas and at the same time the gas is discharged from the open chamber into the return line: the actuator performs the closing operation driven by the piston movement, and the valve moves from the open position to the close (safety-related) position.

Figure 16. Cylinder Chamber Open/Close Action

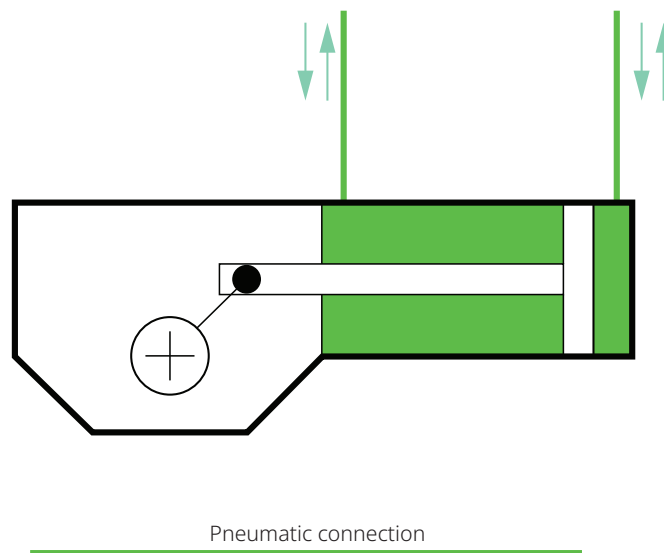

For local or remote operations, please refer to Sections 3.3.1, 3.3.2, 3.3.3, 3.3.4 and prior to technical documentation furnished with actuators. Typical schematics for various applications that follow are attached for information only; in these schematics, actuator operation speed (see Section 3.5) is adjustable by bidirectional flow regulators (item 276) for GIG and GIG with manual jackscrew or handwheel (see Figure 16); for models with manual hand pump, speed is adjusted by unidirectional flow regulators (item Fa – Fc) placed on manual override body (refer to Figures 18 and 19).

The power and control systems are supplied on specific customer demand.

⚠ WARNING

For all the relevant information, please refer to the specific documentation supplied.

3.1.1 Typical Control Schematics

Figure 17. Direct Gas Actuator Local and Remote Control With “MSJ” (GIG-1)

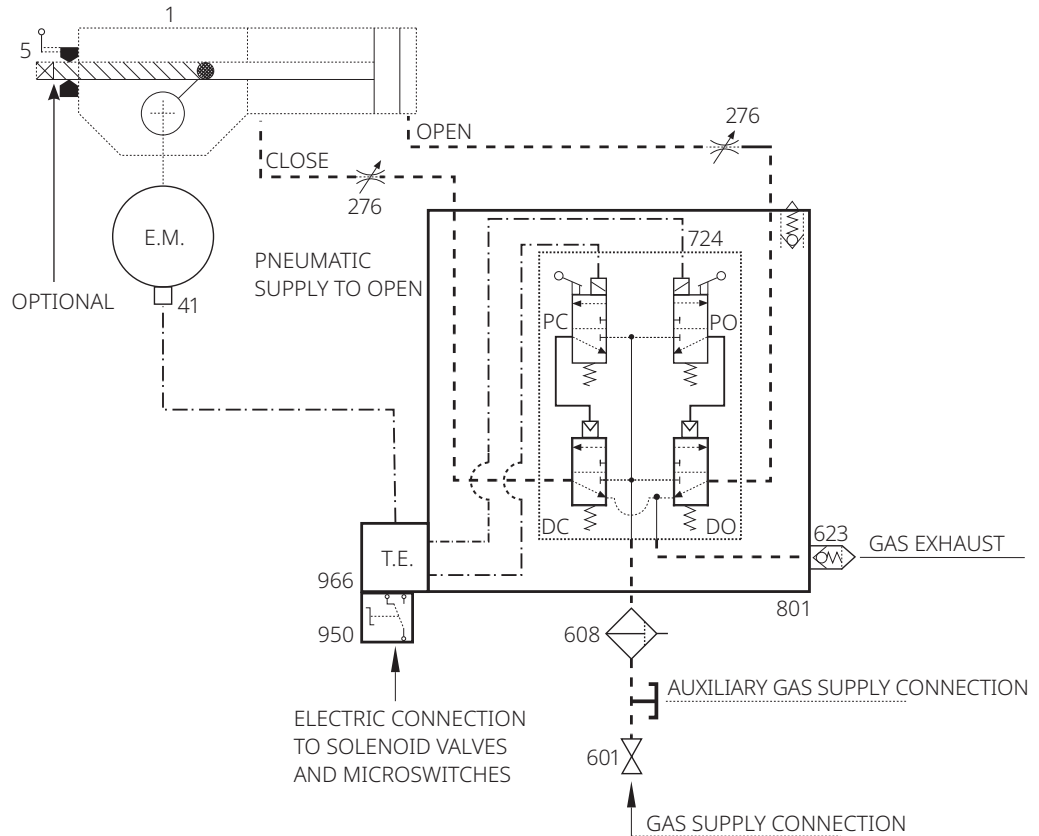

Table 9. Parts List

Item	Description
1	Double-acting pneumatic actuator
5	Manual override
41	Electric microswitches
276	Bidirectional flow regulator (adjustable setting)
601	Stop valve
608	Gas filter/condensate separator
623	Dust excluder with check valve
724	Double 3/2 N.C. solenoid valve with manual override PC = 3/2 N.C. Pil. solenoid valve with manual override (to close) PO = 3/2 N.C. Pil. solenoid valve with manual override (to open) DC = 3/2 N.C. Pneumatic pilot/spring-return valve (to close) DO = 3/2 N.C. Pneumatic pilot/spring-return valve (to open)
801	Control valves enclosure with vent valve
950	Hand operated electric switch
966	Terminal enclosure

Figure 18. Direct Gas Actuator Local and Remote Control With "MHP" (GIG-2)

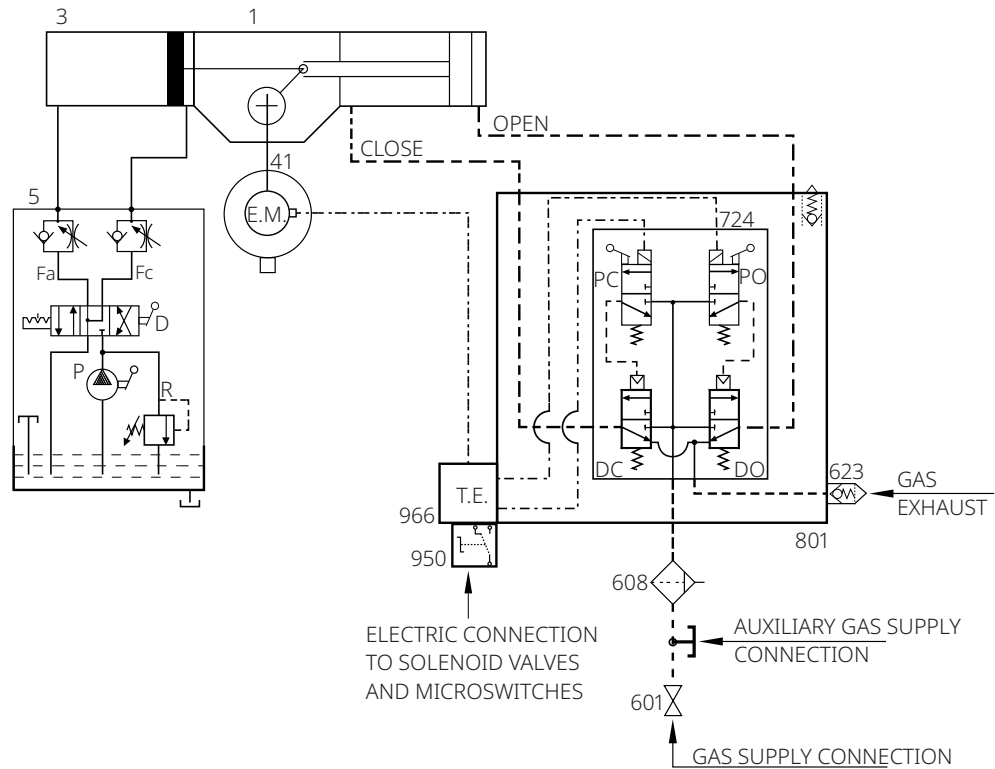

Table 10. Parts List

Item	Description
1	Double-acting pneumatic actuator
3	Hydraulic cylinder
5	Manual override
R	Relief valve
P	Hand pump
D	Hand operated directional control valve
Fa	Unidirectional flow regulator (opening operation)
Fc	Unidirectional flow regulator (closing operation)
41	Electric microswitches
601	Stop valve
610	Gas dehydrating filter/condensate separator
623	Dust excluder with check valve
724	Double 3/2 N.C. solenoid valve with manual override PC = 3/2 N.C. Pil. solenoid valve with manual override (to close) PO = 3/2 N.C. Pil. solenoid valve with manual override (to open) DC = 3/2 N.C. Pneumatic pilot/spring-return valve (to close) DO = 3/2 N.C. Pneumatic pilot/spring-return valve (to open)
801	Control valves enclosure with vent valve
950	Hand operated electric switch
966	Terminal enclosure

Figure 19. Direct Gas Actuator Local and Remote Control - Twin Gas Cylinder (GIG-3)

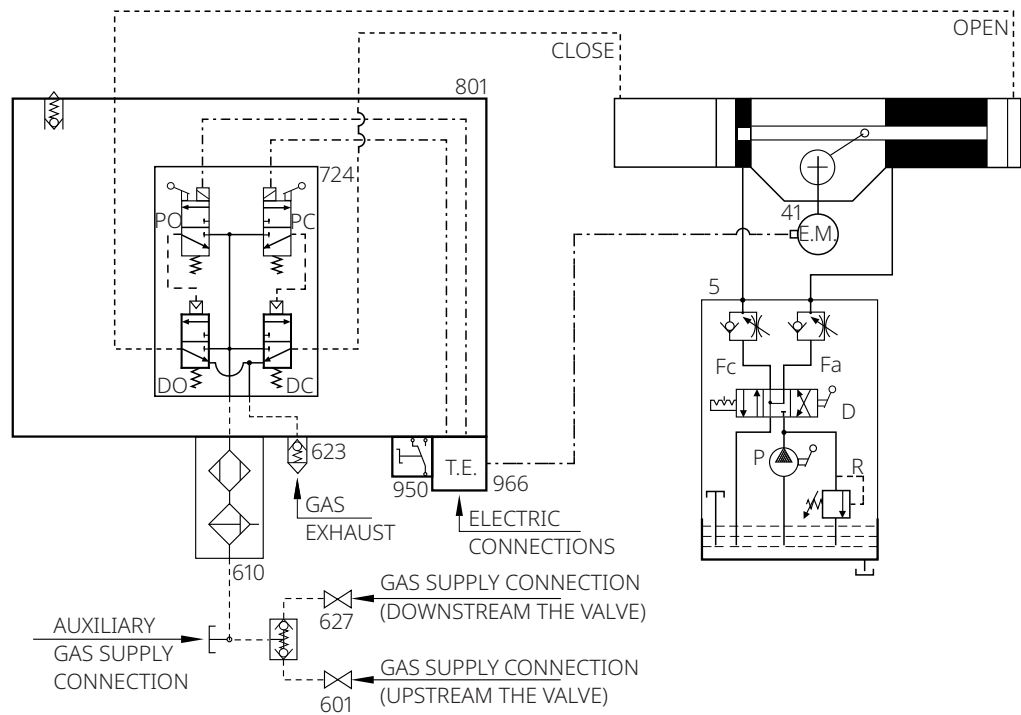

Table 11. Parts List

Item	Description
1	Double-acting pneumatic actuator
5	Manual override
R	Relief valve
P	Hand pump
D	Hand operated directional control valve
Fa	Unidirectional flow regulator (opening operation)
Fc	Unidirectional flow regulator (closing operation)
41	Electric microswitches
601	Stop valve
610	Gas dehydrating filter/condensate separator
623	Dust excluder with check valve
724	Double 3/2 N.C. solenoid valve with manual override PC = 3/2 N.C. Pil. solenoid valve with manual override (to close) PO = 3/2 N.C. Pil. solenoid valve with manual override (to open) DC = 3/2 N.C. Pneumatic pilot/spring-return valve (to close) DO = 3/2 N.C. Pneumatic pilot/spring-return valve (to open)
801	Control valves enclosure with vent valve
950	Hand operated electric switch
966	Terminal enclosure

3.2 Residual Risks

⚠ WARNING

It is recommended to approach the exhaust gas in an unsafe manner (i.e., drive the air avoiding personnel). The actuator has parts under pressure. Exercise due caution. Use individual protections provided for by the laws and provisions in force.

3.3 Operations

3.3.1 Local Pneumatic Operation

⚠ WARNING

Use the proper safety measures to protect from any pressurised gas not piped and from excessive and harmful noises.

Figure 20. Double Solenoid Valve with Manual Control



- Operate the manual control lever of the double solenoid valve in the control group, relevant to the operation to carry out (opening or closing), see Figure 20.
- Check the correct operation of the actuator through the visual position indicator.
- Release the lever to terminate the operation.

3.3.2 Electric Remote Control to Open and to Close

- From the control room, send the electric signal corresponding to the operation to carry out: energize solenoid valve 724-PO to open or 724-PC to close the actuator, during all the valve stroke.
- Solenoid valves must be de-energized at the end of actuator operation.

3.3.3 Emergency Manual Operation by MSJ/MHW

See Figure 17 when sufficient line pressure is not available.

Figure 21. MSJ/MHW Operator

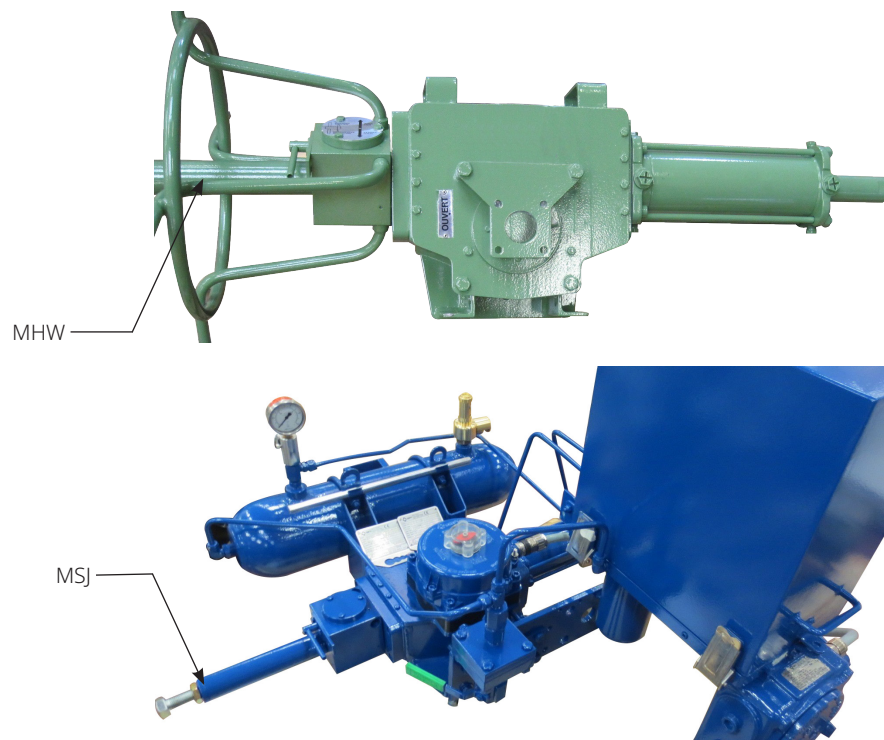

The **MSJ** (jackscrew manual override with removable lever) or the **MHW** (jackscrew manual override with handwheel), can be supplied for GIG actuators up to model 3.

- Engage the manual override by rotating its handle.
- Turn the lever (or the handwheel) the manual override clockwise to close, or counterclockwise to open.
- Check the correct operation of the actuator through the visual position indicator.

Figure 22. Local and Remote Selection Label

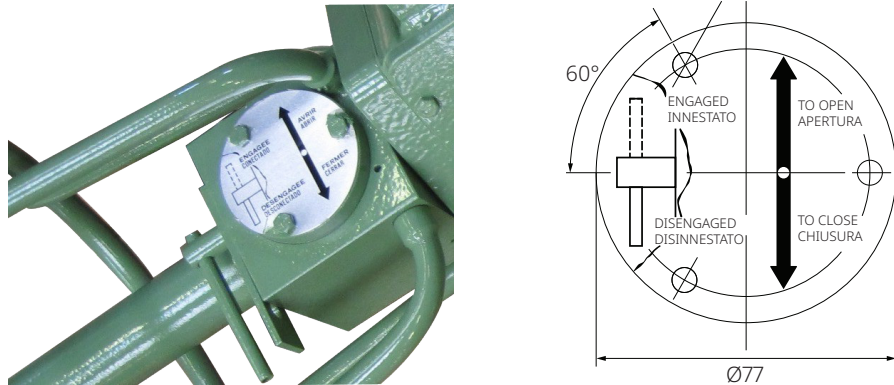

NOTICE

To avoid any intentional actuation of manual override, a lockable device can be supplied as option. For safety related applications, a remote signal for MHW/MSJ engaged (by switch) can be supplied as an option.

Table 12. Manual Operations Per Stroke

Actuator Model	Jackscrew Turns Per Stroke
0.3S - 75 MSJ	30
0.3S - 100 MSJ	30
0.9S - 100 MSJ	35
0.9S - 135 MSJ	35
1.5S - 135 MSJ	35
1.5S - 175 MSJ	35
3S - 135 MSJ	56
3S - 175 MSJ	56

WARNING

If no other manual operation is carried out, disengage the manual override to allow operation with pneumatic supply.

To ensure that the manual override has been correctly disengaged after a manual override operation, the following actions must be done:

- Rotate the handle of MHW or MSJ in “disengaged position.”
- To check the remote functionality, execute operations from remote control, for example partial stroke test (please refer to “Operating Diagram” and the Safety Manual for partial stroke test description) for safety related applications (please see Section 7.2, Figure 48).

3.3.4 Emergency Manual Operation by MHP

See Figures 18 and 19 – when sufficient line pressure is not available.

Figure 23. MHP General Arrangement



Figure 24. Local and Remote Selection Label

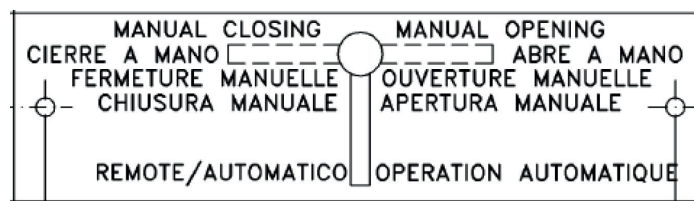

- Select by the lever 5-D the manual opening or manual closing operation.
- Actuated the pump 5-P until to reach the complete operation.
- Check the correct operation of the actuator through the visual position indicator.

Table 13. Manual Operations Per Stroke

Actuator Model	Hand Pump Operations Per Stroke	Actuator Model	Hand Pump Operations Per Stroke
0.3*- 75 MHP 75	40	14*- 280 MHP 200	580
0.3*- 100 MHP 75	40	14* - 280 MHP 235	800
0.3*- 100 MHP 100	70	14*- 280 MHP 280	1140
0.9*- 100 MHP 100	80	18*- 235 MHP 235	900
0.9*- 135 MHP 100	80	18*- 280 MHP 235	900
0.9*- 135 MHP 135	150	18*- 280 MHP 280	1300
1.5*- 135 MHP 135	180	32*- 235 MHP 235	1080
1.5*- 175 MHP 135	180	32*- 280 MHP 235	1080
1.5*- 175 MHP 175	300	32*- 280 MHP 280	1500
3*- 135 MHP 135	290	50*- 235 MHP 235	1200
3*- 175 MHP 135	290	50*- 280 MHP 235	1200
3*- 175 MHP 175	490	50*- 280 MHP 280	1700
6*- 175 MHP 175	400	50*- 300 MHP 235	1200
6*- 200 MHP 175	400	50*- 300 MHP 280	1700
6*- 200 MHP 200	520	50*- 300 MHP 300	1930
14*- 200 MHP 200	580	80*- 280 MHP 280	1983
14*- 235 MHP 200	580	80*- 300 MHP 300	2251
14*- 235 MHP 235	800	80*- 350 MHP 350	3063

⚠ WARNING

If no other manual operation is carried out, the lever 5-D must be in “remote operation” position to allow the operations with gas supply.

To ensure that the manual override has been correctly disengaged after a manual override operation, the following actions must be done:

- Rotate the lever 5-D of MHP in “Remote operation” position.
- To check the remote functionality, execute operations from remote control, for example partial stroke test (please refer to “Operating Diagram” and the Safety Manual for partial stroke test description).

NOTICE

To avoid any intentional actuation of manual hand pump, a lockable device can be supplied as an option. For safety related applications, a remote signal for MHP engaged (by switch) can be supplied as an option.

Figure 25. MHP with Lockable Engagement Lever

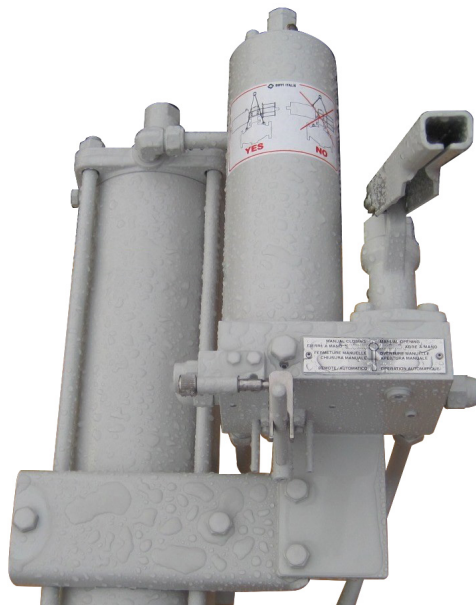
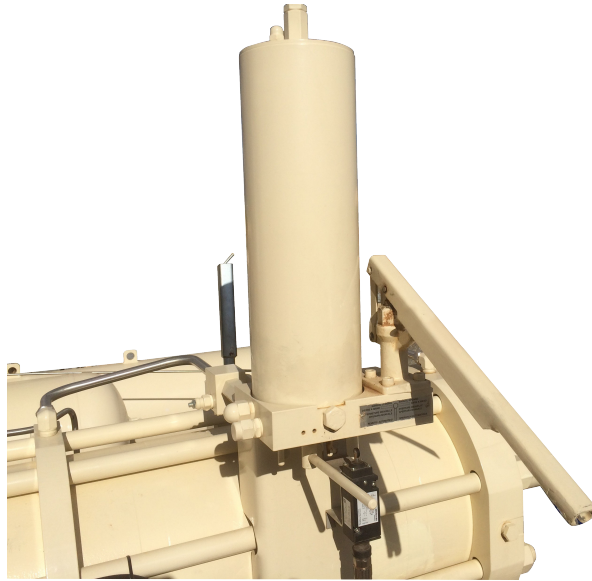
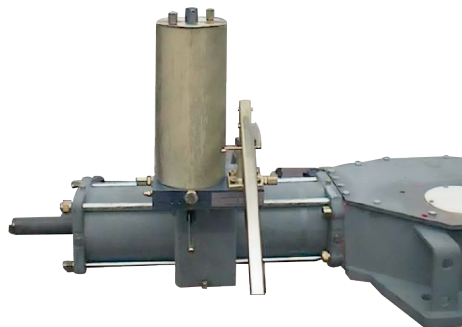

Figure 26. MHP with Lockable Hand Pump and Signalling Switch

(Please see also Section 7.2, Figure 46).

NOTICE

Assemble the MHP in vertical position (as shown in Figure 27) so the actuator will work properly. Any other mounting position is strictly forbidden.

Figure 27. MHP General Arrangement

3.4 Calibration of the Angular Stroke

The angular stroke of the yoke can be adjusted between 82° and 98° ($\pm 4^\circ$ with respect to the nominal positions of complete opening and closing) by means the mechanical stops screwed into the left side of the housing (open valve) and into the end flange of the hydraulic cylinder (closing) (Figure 28).

Figure 28. Mechanical Stops



In case of an actuator with two cylinders (Figure 29), both mechanical stops are screwed on the end flanges of the cylinders.

Figure 29. Actuator with Two Cylinders



For the adjustment of the mechanical stop on the end flange of cylinder, follow these steps (Figure 30):

- Remove with the specific wrench (c1) the plug (t).
- Insert a wrench for Allen keys (c2) in the through hole until reaching the adjustment pin (g).
- Keep the protection cover blocked with the special wrench (c3).
- Turn counterclockwise to increase the angular stroke, turn clockwise to decrease it.
- When the adjustment is over, tighten the plug (t).

Figure 30. Mechanical Stop of the Cylinder

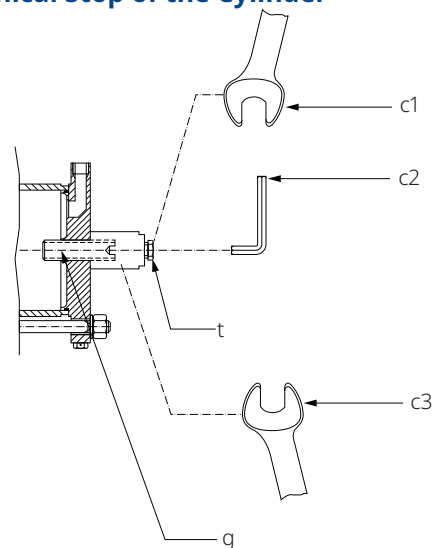

Table 14. Travel Stop Adjustment Tools Size

Hydraulic Cylinder Size	Wrench c1 (mm)	Wrench c2 (mm)	Wrench c3 (mm)
075	22	10	36
100	22	10	36
135	22	10	36
175	22	14	46
200	27	14	46
235	27	17	65
280	27	17	65
300	36	17	110

For the adjustment of the mechanical stop screwed into the left side of housing, follow these steps (Figures 31 and 32):

- Loosen the locknut (d) with the specific wrench (c2).
- Adjust the pin (g)/screw (v) with the adequate wrench (c1).
- Turn counterclockwise to increase the angular stroke, turn clockwise to decrease it.
- When the adjustment is over, tighten the locknut (d).

Figure 31. Mechanical Stop on the Housing

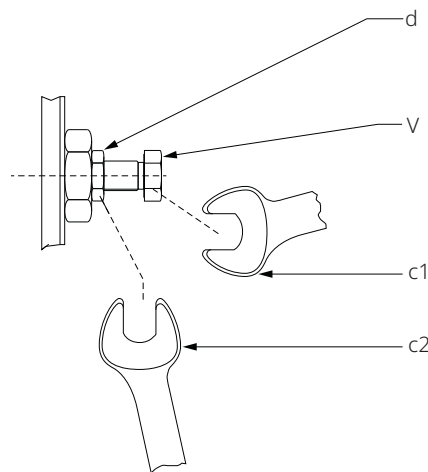

Table 15. Travel Stop Adjustment Tools Size

GIG Actuator Model	Wrench c1 (mm)	Wrench c2 (mm)
0.3	30	30
0.9	30	30
1.5	41	41
3	41	41
6	46	46

Figure 32. Mechanical Stop on the Housing

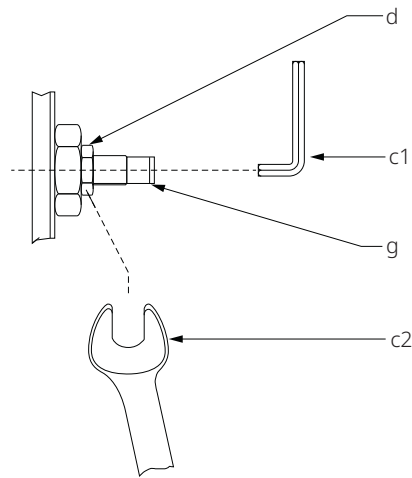
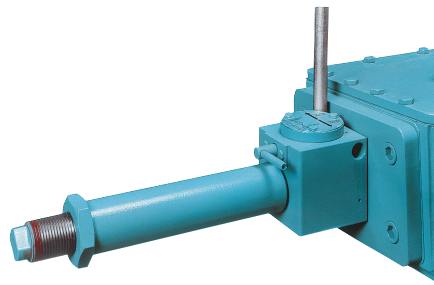

Table 16. Travel Stop Adjustment Tools Size

GIG Actuator Model	Wrench c1 (mm)	Wrench c2 (mm)
14	17	60
18	17	60
32	17	60
50	17	60

Figure 33. (Optional - If Foreseen)



For the adjustment of the mechanical stop screwed on the end flange of the manual override (see Section 7.2, Figure 48).

Figure 34. Mechanical Stop on the End Flange of Manual Override

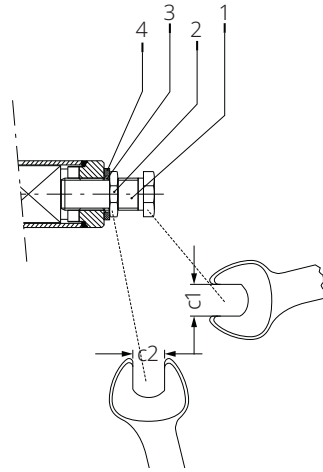

Table 17. Travel Stop Adjustment Tools Size

GIG Actuator Size	Wrench c1 (mm)	Wrench c2 (mm)
0.3	34	34
0.9	34	34

Figure 35. Mechanical Stop on the End Flange of Manual Override

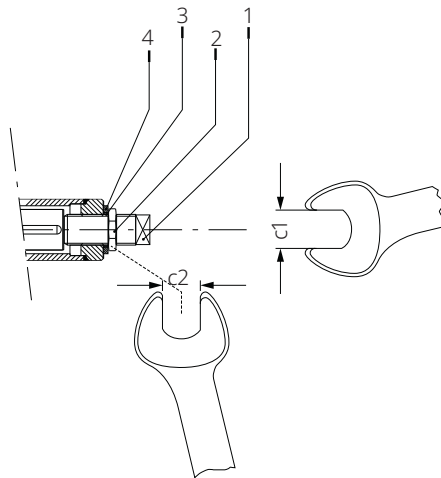

Table 18. Travel Stop Adjustment Tools Size

GIG Actuator Size	Wrench c1 (mm)	Wrench c2 (mm)
1.5	24	65
3	24	65

3.5 Calibration of Microswitches (If Foreseen)

Refer to Safety Instructions Manual for limit switch box.

⚠ WARNING

Refer only to technical documentation related to installed switch box model.

NOTICE

For mounting interface dimension of the limit switch box on the cover of the actuator, please refer to TN1163V (for metric dimension) or TN1163VU (for imperial dimension).

NOTICE

Operate only the microswitch corresponding to the direction of operation being carried out, as clearly reported on the microswitch. End of stroke microswitches should be operated before the stop of the stroke of the actuator due to mechanical stops. Adjust the relative cams properly.

3.6 Calibration of the Operation Time

The calibration of the operation time is made by Biffi, according to customer requirements and to technical data sheet included in technical documentation. If necessary, it is possible to modify or reset the operating time through two-flow regulation valves placed between the control valves enclosure and the pneumatic cylinder (Figure 36).

Figure 36. Adjustment of Operation Time

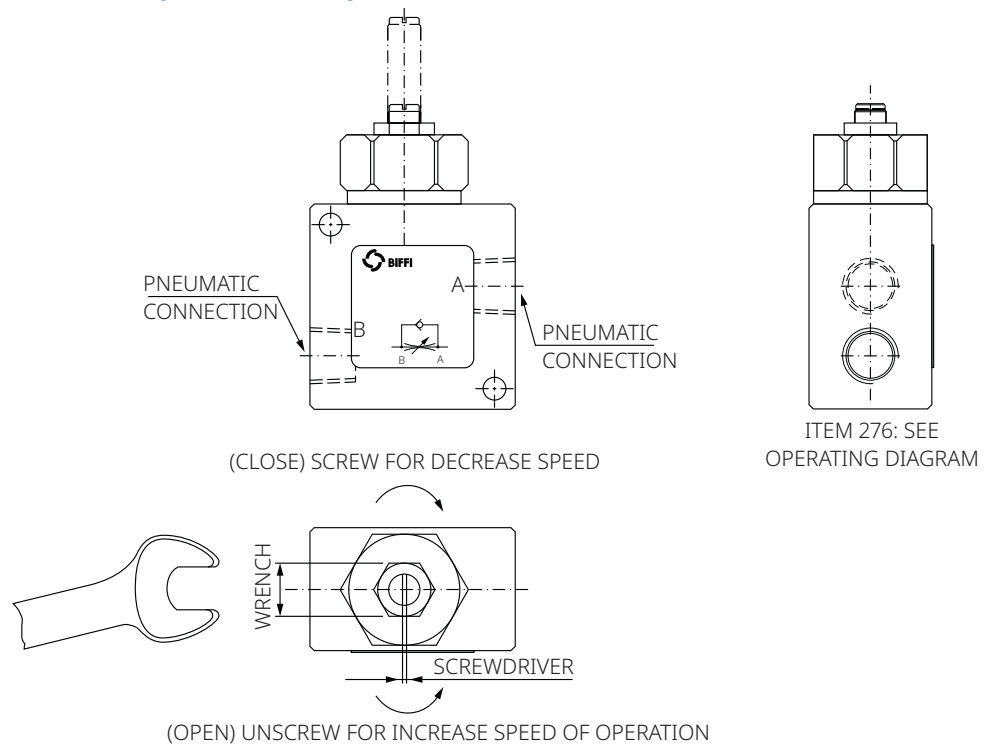

To carry out the adjustment, use an adequate Allen wrench and follow these steps (Figure 36):

- Loosen the locknut.
- Screw with a screwdriver the setting screw to increase the operation time.
- Unscrew with a screwdriver the setting screw to decrease the operation time.
- After the adjustment is over screw the locknut.

For GIG actuator models with a manual hand pump, the operating time is adjustable through two regulation valves placed on manual hand pump body (see Section 7.2, Figure 46).

To carry out the adjustment, use an adequate Allen wrench and follow these steps (Figure 37):

- Remove the cap nut.
- Loosen the locknut.
- Screw with a screwdriver the setting screw to increase the operation time.
- Unscrew with a screwdriver the setting screw to decrease the operation time.
- After the adjustment is over screw the locknut and put back in place the cap nut.

Figure 37. Flow Regulators Placed on Manual Hand Pump

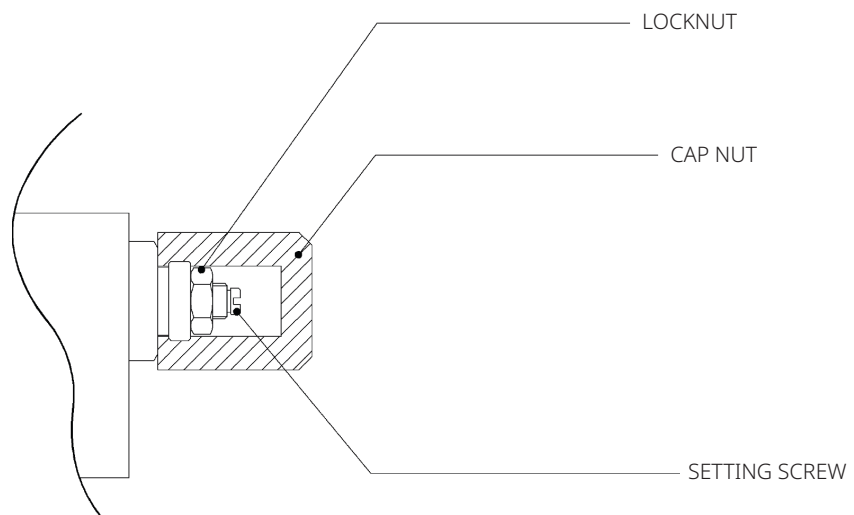

Section 4: Operational Tests and Inspections

NOTICE

To ensure the guaranteed SIL grade, according to IEC 61508, the functionality of the actuator must be checked at regular intervals, as described in the Safety Manual.

Section 5: Maintenance

NOTICE

Before executing any maintenance operation, it is necessary to close the pneumatic supply line and discharge pressure from the cylinder of the actuator and from the control unit (if foreseen).

⚠ WARNING

Installation, commissioning and maintenance and repair works should be carried out by qualified staff.

5.1 Periodic Maintenance

GIG actuators are designed to operate long-term in heavy-duty operating conditions, without maintenance needs.

NOTICE

The periodicity and regularity of the inspection plan are particularly influenced by, but not limited to, specific environmental working conditions and the number of cycles performed. On average, replacing consumable, such as O-rings, is recommended every four years. Visual inspections of actuator status may include checks for paint condition and leakage, which are important periodic maintenance activities. The inspection frequency can be adjusted—either extended or reduced—based on specific environmental and working conditions. For example, offshore and near-shore applications require more frequent checks of critical components, including protective coatings, grease on unpainted exposed parts, and materials that are not stainless steel or of superior quality. The frequency of the controls can be initially determined experimentally and then be improved according to maintenance conditions and needs.

Every 2 years of operation, the following is recommended:

- Check that the actuator operates the valve correctly and with the required operating times. If the actuator operation is very infrequent, carry out a few opening and closing operations with all the existing controls (remote control, local control, emergency controls, etc.), if this is allowed by the conditions of the plant.
- Check if there are no hydraulic or pneumatic leakages.
- Check oil level (Figure 38) into the hydraulic control unit (See Section 5.1.1)
- Check if the actuators did not undergo accidental damage with oil leakages found on site (Section 5.1.1).
- Check that improper closing of control-group cover did not produce the presence of condensation on it.
- Check the integrity of worn out parts (gaskets, pads, etc.).
- If there is an oil filter on the actuator, bleed the condense water accumulated in the cup by opening the drain cock. Disassemble the cup periodically and wash it with soap and water; disassemble the filter: if this is made up of a sintered cartridge, wash it with nitrate solvent and blow through with oil. If the filter is made of cellulose, it must be replaced when clogged.

Figure 38. Level Measuring Stick

5.1.1 Check and Restore Oil Level in the Hydraulic Manual Override

Operate the distributor lever to “closing manual operation”.

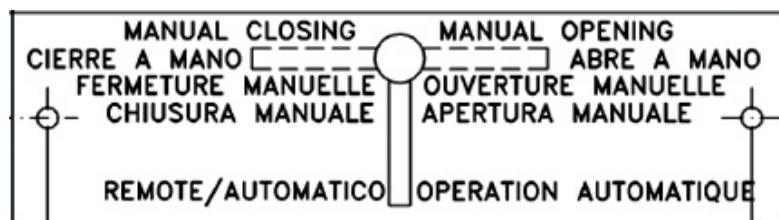
Figure 39. Local and Remote Selection Label

Move the actuator into his “fail to close” position.

Unscrew the dipstick (1).

Check that the oil level in the tank (4) is in correspondence of the “MAXIMUM LEVEL” notch of the dipstick.

Screw and tighten the dipstick.

If necessary, substitute or add the oil, proceeding as follow:

- Remove the dipstick (1) from the tank cover (22).
- Unscrew the plug (27) and the washer (9) to drain all the oil.
- If some dirt or/and sludge is found in the oil drained from the tank, before filling with new oil in the tank, disassemble the oil tank tube, by unscrewing the two cap nuts (2), and clean the internal surfaces of the tank. If necessary, substitute the gaskets (21) of the tank.
- Replace the plug (27) and the washer (9) into the plate (11) and tighten.
- Pour the new oil into the tank through the dipstick hole (1) on the cover (22).
- Replace the dipstick (1).
- Add oil (refer to Table 19) if the oil level in the tank is BELOW THE MINIMUM (Figure 38: minimum level is in correspondence to the end of dipstick) until it reaches the optimal (MAXIMUM) oil level .
- Operate the distributor lever to “Remote” position.

NOTICE

For refill use oil of the same brand as previous, refer to related technical documentation.

Table 19. Hydraulic Oil List by Biffi for Refilling in Different Working Conditions

Standard Temperature Conditions (-30 to +85 °C):	
Producer	ENI®
Name	Arnica 22
Viscosity at 40 °C	20.9 sq. mm/s
Viscosity at 100 °C	4.73 sq. mm/s
Viscosity index ASTM	153
Flash point	192 °C
Pour point	-42 °C
Specific weight (at 15 °C)	0.857 kg/L
Equivalent oils	Use an equivalent or better product in compliance with the oil proposed in the actual scope of supply by Biffi. Your oil supplier can verify and propose an alternative product at your responsibility.
Low Temperature Conditions (to -46 °C):	
Manufacturer	Shell AeroShell® Fluid 41
Viscosity at -54 °C	2300 cST
Viscosity at -40 °C	491 cST
Viscosity at 40 °C	14.1 cST
Viscosity at 100 °C	5.30 cST
Viscosity index (ISO 2909)	>200
Flash point	105 °C
Pour point	<-60 °C
Specific weight (Or equivalent)	0.87 kg/cu. dm
(or equivalent)	
Low Temperature Conditions (to -60 °C):	
Manufacturer	SYNTHESIS *
Name	SYNTRASS-CS 500 *
Viscosity at -60 °C	580 cST
Viscosity at -30 °C	39 cST
Viscosity at 20 °C	5.8 cST
Viscosity at 50 °C	2.1 cST
Flash point	152 °C
Pour point	-68 °C
Specific weight (Or equivalent)	0.897 kg/cu.dm
(or equivalent)	

NOTE:

* Refer to Biffi to receive a quotation for this oil.

Gas supply dehydrating filter maintenance (if foreseen)

The gas supply filter is fitted with a mechanical filter and a drain valve to discharge periodically the water generated by the condensation of the humidity inside the gas supply.

During the routine maintenance it is recommended to check and clean the mechanical filter and replace it in case of heavy dirty conditions.

To disassemble the filter, proceed as follow:

1. Close the stop valve at the inlet of pressure supply line.
2. Discharge the pressure from the drain valve.
3. Remove the lower enclosure screws.
4. Remove the mechanical filter.
5. Clean or replace the filter.

Reinstall all parts carefully paying attention to avoid any damage to the O-ring.

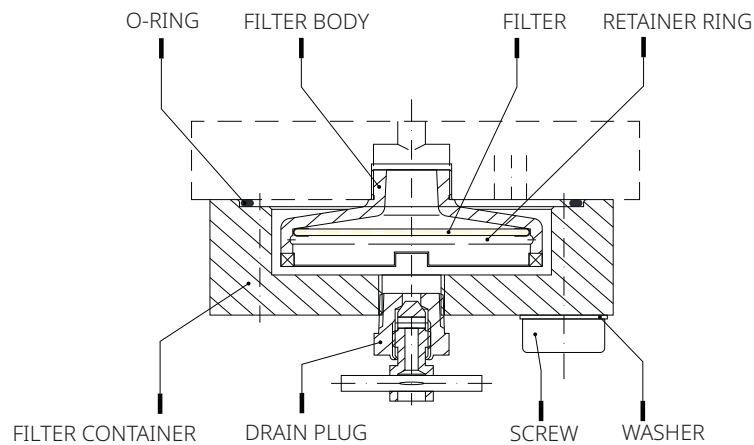
Figure 40. Mechanical Filter System

5.2 Extraordinary Maintenance

If there are leaks in the hydraulic cylinder, or a malfunction in the mechanical components, or in case of scheduled preventive maintenance, the actuator must be disassembled and seals must be replaced with reference to the following general sectional drawing and adopting the following procedures.

5.2.1 Replacement of Cylinder Seals

NOTICE

Before executing any maintenance operation, it is necessary to intercept the supply line and discharge pressure from the cylinder of the actuator.

⚠ WARNING

If the actuator can be operated, it is essential to take it to fail-safe position, otherwise the actuator should be disassembled from the valve and follow these steps.

1. Unscrew the plug (23) from the cylinder end flange.
2. Measure the distance of the stop screw (20) with reference to the end flange (22) surface, so as to be able to easily restore the setting of the actuator mechanical stop, once the maintenance procedures have been completed.
3. Unscrew the stop screw (20) by turning it counter clockwise with an Allen wrench until the screw is completely with drawn inside the end flange threaded hole.
4. Unscrew the nuts (25) from the tie rods (18): they must be gradually unscrewed all at the same time.
5. Slide off the end flange (22) and the tube (21).
6. If the actuator control unit requires the cylinder chamber head flange side to be also filled with oil, and the piston rod seal ring (40) to be replaced, remove the screw (2) and the cover (1). Unscrew the piston rod (17) threaded end from the adaptor bush (30) of the guide block (14). Slide off the piston rod (17) from the head flange (42).
7. If the gaskets (37 and 39) need to be replaced due to damage, remove the screws (31) to disassemble the head flange (42) from the mechanism housing (8).

5.2.1.1 Seals Replacement

Prior to reassemble, check if the actuator components are in good condition and clean. Lubricate all the surfaces of the parts, which move in contact with other components, by recommended grease Molykote® 2003 or Lubcon Turmoplex LTA 2 if seals are NBR (Nitrile Butadiene Rubber) or Viton® (FKM) or neoprene rubber, with Mobilgrease™ 33 if the seals are in fluorosilicone rubber). If the O-ring must be replaced, remove the existing one from its groove, clean the groove carefully and lubricate it with protective grease film. Assemble the new O-ring into its groove and lubricate it with a protective grease film.

Assemble the new O-ring into its groove and lubricate it with a protective oil film.

1. Replace the O-ring (43) of the head flange (42).
2. Replace the O-ring (43) of the end flange (42).

To replace the piston rod seal rings (40) proceed as follows:

1. Remove the existing polytetrafluoroethylene (PTFE) seal ring (40) with its O-ring from their groove.
2. Clean the groove carefully and lubricate it with a protective oil film.
3. Assemble the new O-ring into its groove and lubricate it with a protective oil film.
4. Assemble the new PTFE seal ring (40) into the flange groove, inside its rubber O-ring, by bending it: take care that the bending radius is as large as possible to avoid damaging the seal. Then enlarge the seal ring with your fingers so as to restore its round shape: pay attention not to utilize any tools, which can damage the seal ring.

To replace the piston seal ring (46) proceed as follows:

1. Remove the existing PTFE seal ring (46) with its O-ring from their groove.
2. Clean the groove carefully and lubricate it with a protective oil film.
3. Assemble the new O-ring into its groove and lubricate it with a protective oil film.
4. Assemble the new PTFE seal ring (46) on its rubber O-ring by introducing one side of it into the groove, then enlarge it with your fingers so as to fit it into the groove: take care to enlarge it uniformly without any tools which could possibly damage it. The elastic memory of the kind of PTFE the seal ring is made out of allows the ring to shrink back to its previous dimension after a short time.

5.2.1.2 Reassemble

1. Assemble the new gasket (37 and 39) after cleaning the surfaces of housing (8), the flange (38) and head flange (42), which are in contact.
2. Assemble the head flange (42), replace the washers if damaged, tighten the screws (31) to the recommended torque.
3. Lubricate the piston rod (17) surface, with a protective oil film and introduce it into the head flange hole, taking care not to damage the O-ring (39). Carefully clean the threaded end of the piston rod (17) and the threaded hole of the adaptor bush (30) of guide block (14). Spread some sealant LOCTITE® 452, or equivalent, on the rod threaded end and tighten.
4. Carefully clean the inside of the tube (21) and check that the entire surface, particularly that of the bevels, is not damaged. Lubricate with a protective oil film the tube internal surface and the bevels at the ends. Slide the tube onto the piston taking care not to damage the PTFE seal ring (46): the tube bevel has to smoothly compress the seal ring; take care also not to damage the head flange O-ring (43).
5. Assemble the end flange by centring it on the inside diameter of the tube, taking care not to damage the O-ring (43).
6. Assemble the nuts (25) onto the tie rods (18). Tighten the nuts to the recommended torque, alternating between opposite corners.
7. Restore a generous coating of grease on the contact surfaces of the yoke (11) and the bushings (33), on the yoke grooves, on the sliding blocks (5), on guide bar (9).
8. Assemble the new gasket (10) after cleaning the surfaces of the housing (8) and cover (1).
9. Lubricate with protective oil or grease the O-ring (32).
10. Assemble the cover (1) and the screws (2). Tighten the screws to the recommended torque.
11. Screw the stop screw (20) by turning it clockwise with an Allen wrench until it reaches its original position (the same distance with reference to the end flange surface).
12. Screw the plug (23) into the cylinder end flange.

NOTICE

After maintenance operations, carry out a few actuator operations (5 to 10) to check that its movement is regular, that there is no air leakage through the seals and to eliminate any oil residues in the air circuit, deriving from the lubrication of the seals during the replacement phase.

Figure 41. GIG-MHP Double-Acting Pneumatic Actuator

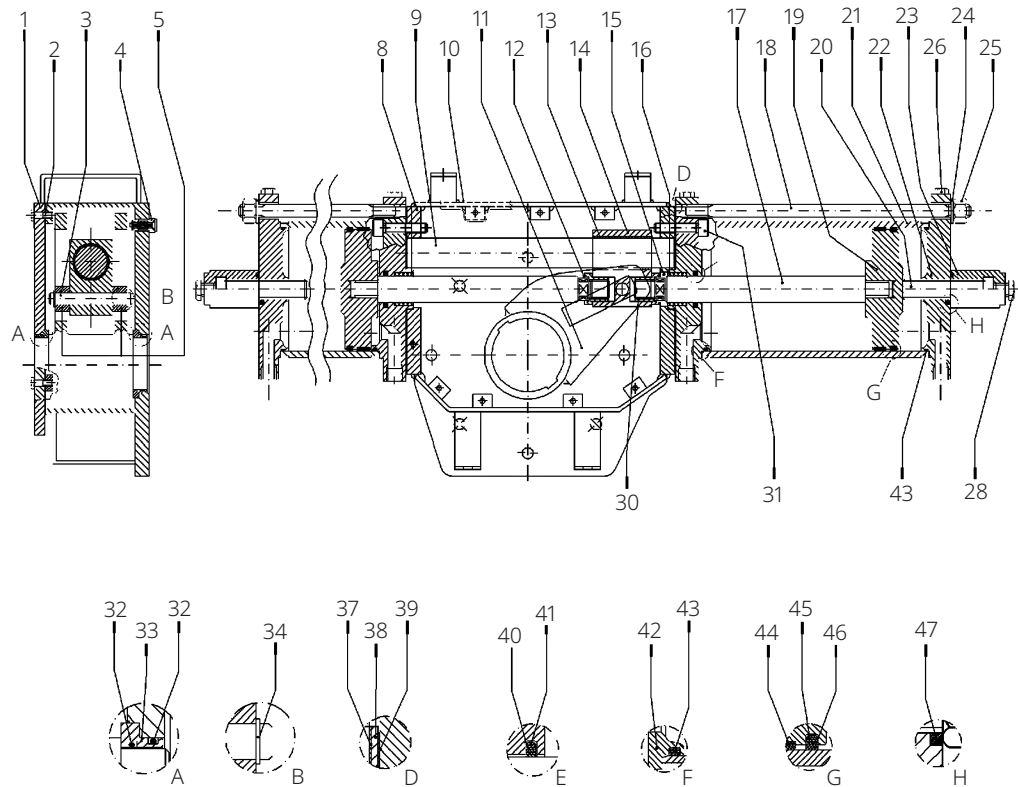

Table 20. Parts List

Item	Description	Item	Description
1	Cover	24	Spring washer
2	Screw	25	Nut
3	Guide block pin	26	Plug
4	Vent valve	28	Nut
5	Sliding block	30	Adaptor bush
8	Housing	31	Screw
9	Guide bar	32	O-ring
10	Cover gasket	33	Yoke bushing
11	Yoke	34	Retainer ring
12	Plug	37	Gasket
13	Bushing	38	Flange
14	Guide block	39	Gasket
15	Washer	40	Piston rod seal ring
16	Piston rod bushing	41	O-ring
17	Piston rod	42	Head flange
18	Tie rod	43	O-ring
19	Piston	44	Guide sliding ring for piston
20	Stop setting screw	45	O-ring
21	Cylinder tube	46	Piston seal ring
22	End flange	47	Sealing washer
23	Stop setting screw cover		

5.3 Dismantling and Demolition

Before starting the disassembly, a large area should be created around the actuator to allow any kind of movement without problems of further risks created by worksite.

WARNING

Before disassembling the actuator, it is necessary to close the pneumatic feed line and discharge oil pressure from the cylinder of the actuator, from the control unit and from the accumulator tank, if present.

If actuator is still mounted onto the valve, loosen the threaded connections between valve and actuator (screws, tie rods, nuts).

Lift the actuator using the proper lifting points, see Section 2.2.

If the actuator needs storage, before demolition, see Section 2.3.

WARNING

The demolition of the actuator both concerning any electrical and mechanical parts should be made by specialized staff.

Separate the parts composing the actuator according to their nature (e.g., metallic and plastic materials, fluids, etc.), and send them to differentiated waste collection sites, as provided for by the laws and provisions in force.

5.4 Lubrication of Mechanism

For normal duty, the scotch yoke mechanism of the actuator is lubricated "for life". In case of high load and high frequency of operation it may be necessary to periodically restore lubrication: it is advisable to apply a generous coating of grease on the contact surfaces of the yoke and bushings, on the yoke link grooves, on the sliding blocks, on the guide bar.

For this operation, it is necessary to disassemble the mechanism cover. In larger actuators, the lubrication can be performed through the inspection holes of the cover after removing the plugs.

The following grease is used by Biffi for standard working temperature and suggested for re-lubrication:

ENI MU/EP/2 *

To be used in standard temperature conditions: -30 to +85 °C

NLGI (National Lubricating Grease

Institute) consistency: 2

Worked penetration: 280 dmm

ASTM Dropping Point: 185 °C

Base oil viscosity at 40 °C: 160 sq. mm/s

ISO Classification: L-X-BCHB 2

DIN 51 825: KP2K - 20

Equivalent to: Use an equivalent or better product in compliance with the grease proposed in the actual scope of supply by Biffi. Your grease supplier can verify and propose an alternative product at your responsibility.

Mobilgrease 33 or Equivalent **

To be used in low temperature conditions: -60 to +100 °C

Notes:

- * If the service is not special (i.e., oxygen, hydrogen or other mentioned during the offer stage).
- ** Use an equivalent or better product in compliance with the grease proposed in the actual scope of supply by Biffi. Your grease supplier can verify and propose an alternative product at your responsibility.

Section 6: Troubleshooting

6.1 Failure or Breakdown Research

Table 21. Troubleshooting

Event	Possible Cause	Remedy
Actuator does not work	Lack of power supply	Restore it
	Lack of pneumatic supply	Open line interception valve
	Blocked valve	Repair or replace
	Wrong position of the distributor of the manual hydraulic group	Restore correct position
	Failure of the control group	Call Biffi Customer Service
	Unexpected intervention of torque limit-device	Call Biffi Customer Service
	Low supply pressure	Restore (Section 1.4)
Actuator too slow	Low supply pressure	Restore (Section 1.4)
	Wrong calibration of flow regulator valves	Restore (Section 3.6)
	Wear of the valve	Replace
Actuator too fast	High supply pressure	Restore (Section 1.4)
	Wrong calibration of flow regulator valves	Restore (Section 3.6)
Leakages on hydraulic or pneumatic circuits	Deterioration and/or damage to gaskets	Call Biffi Customer Service
Incorrect position of the valve	Wrong adjustment of mechanical stops	Restore (Section 3.4)
	Wrong warning of microswitches	Restore (Section 3.5)
Hydraulic manual pump does not work	Handle positioned on remote control	Position the handle on the indication of the operation to make
	Leakages on the check valve of the hydraulic control group	Call Biffi Customer Service

Section 7: Spare Parts

7.1 Spare Parts Order

For spare parts order to the relevant Biffi office, please make reference to Biffi order confirmation concerning all the supply, and serial number of the actuator (Section 1.2) for any specific spare part for a specific actuator model.

Please send every spare parts request to:

Biffi - Spare Parts and After Sales Department

Tel.: +39 0523-944523

Fax: +39 0523-941885

E-mail: biffispares@Emerson.com

Please specify:

1. Actuator model
2. Biffi acknowledgement
3. Spare parts code
4. Quantity
5. Transport condition
6. Involved people

7.2 Parts List for Maintenance and Replacement Procedure

**Figure 42. Scotch Yoke Mechanism Standard Version
(Minimum Performed Cycles* = 100.000)**

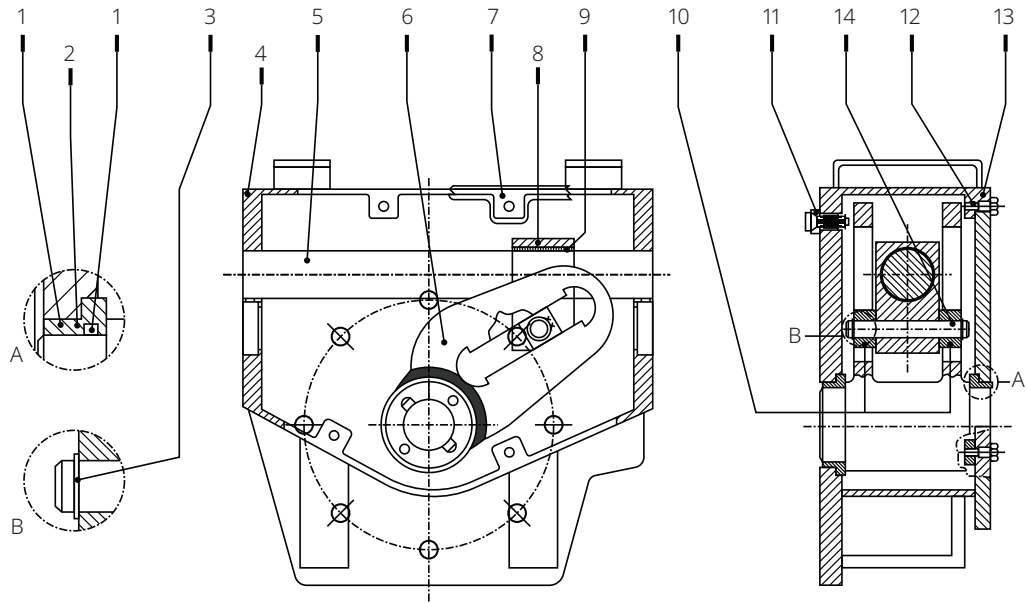

Table 22. Parts List

Item	Quantity	Description	Material
1	4	O-ring	NBR *
2	2	Yoke bushing	Bronze
3	2	Retainer ring	Stainless steel
4	1	Housing	Carbon steel
5	1	Guide bar	Alloy steel
6	1	Yoke	Carbon steel
7	1	Cover gasket	Styrene-butadiene rubber (SBR) * + Cellulose + Fillers
8	1	Guide block	Carbon steel
9	1	Bushing	Steel + Bronze + PTFE
10	2	Sliding block	Bronze
11	1	Vent valve	Stainless steel *
12	12	Screw	Carbon steel
13	1	Cover	Carbon steel
14	1	Guide block pin	Alloy steel

NOTE:

* Recommended spare parts

** Cycles performed by actuator in a 25 years expected lifetime - the minimum performed cycles are guaranteed by Biffi based on service conditions listed:

- All the valve required torques have to be lower than actuator max operating torque (MOT).
- The ratio between valve required running torque and actuator max operating torque (MOT) has to be > 1.5.
- The actuator mechanism has to be lubricated in accordance with indication given on this IOM.

Figure 43. Pneumatic Cylinder

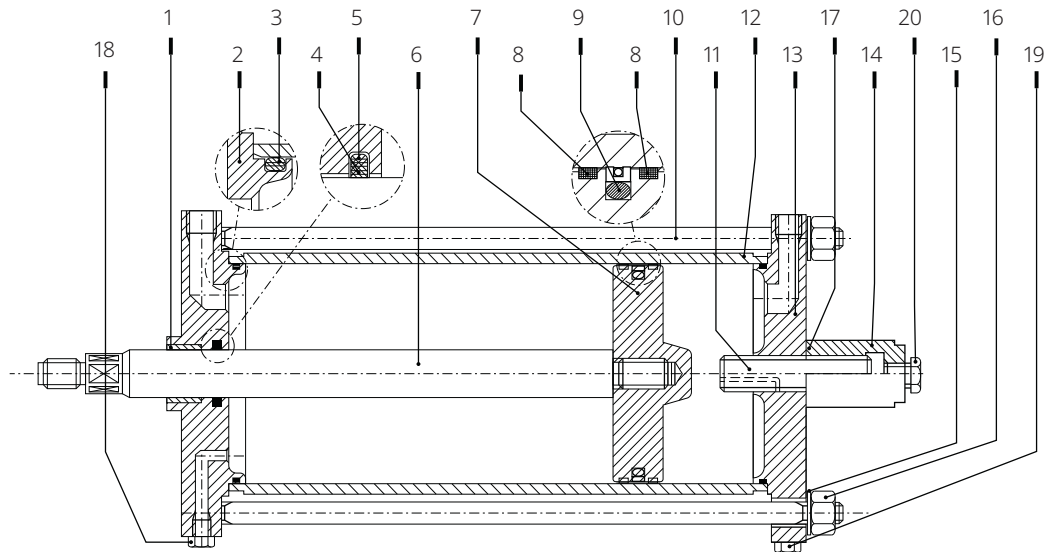
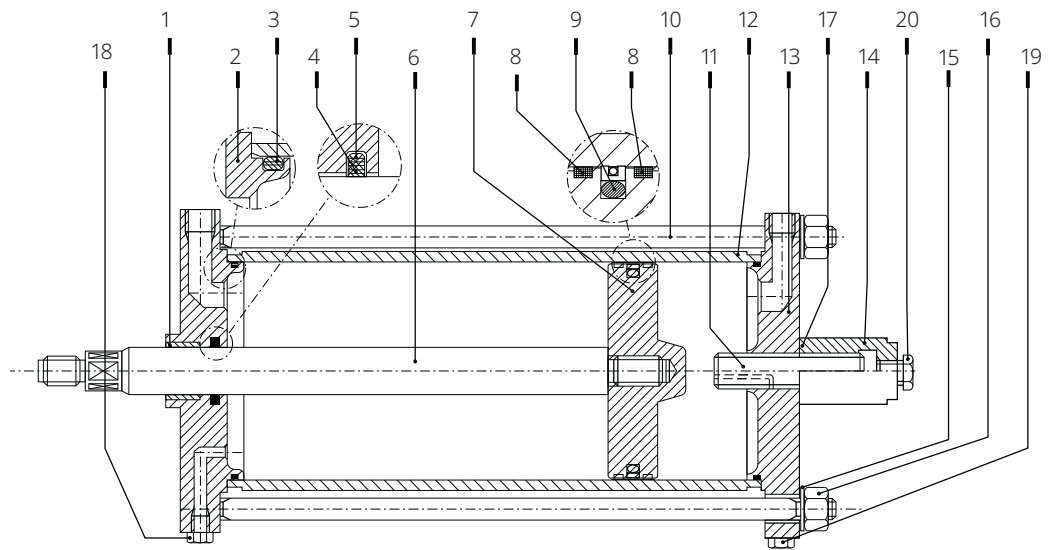

Table 23. Parts List

Item	Quantity	Description	Material
1	1	Piston rod bushing	Steel + Bronze + PTFE
2	1	Head flange	Carbon steel
3	2	O-ring	NBR *
4	1	Piston rod seal ring	PTFE + Graphite *
5	1	O-ring	NBR *
6	1	Piston rod	Alloy steel
7	1	Piston	Nickel plated carbon steel
8	2	Guide sliding ring for piston	PTFE + Graphite *
9	1	Piston seal ring	PTFE + NBR *
10	4	Tie rod	Alloy steel - ASTM A320 Grade L7
11	1	Stop-setting screw	Alloy steel
12	1	Cylinder tube	Nickel plated carbon steel
13	1	End flange	Carbon steel
14	1	Stop-setting screw cover	Carbon steel
15	4	Spring washer	Carbon steel
16	4	Nut	Carbon steel - ASTM A194 Grade 7
17	1	O-ring	NBR *
18	6	Plug	Carbon steel
19	1	Plug	Carbon steel
20	1	Plug	Carbon steel

NOTE:

* Recommended spare parts

Figure 44. Hydraulic Cylinder for MHP**Table 24. Parts List**

Item	Quantity	Description	Material
1	1	Piston rod bushing	Steel + Bronze + PTFE
2	1	Head flange	Carbon steel
3	2	O-ring	NBR *
4	1	Piston rod seal ring	PTFE * + Graphite
5	1	O-ring	NBR *
6	1	Piston rod	Alloy steel
7	1	Piston	Nickel plated carbon steel
8	2	Guide sliding ring for piston	PTFE + Graphite *
9	1	Piston seal ring	PTFE + NBR*
10	4	Tie rod	Alloy steel - ASTM A320 Grade L7
11	1	Stop-setting screw	Alloy steel
12	1	Cylinder tube	Nickel plated carbon steel
13	1	End flange	Carbon steel
14	1	Stop-setting screw cover	Carbon steel
15	4	Spring washer	Carbon steel
16	4	Nut	Carbon steel - ASTM A194 Grade L7
17	1	O-ring	NBR *
18	6	Plug	Carbon steel
19	1	Plug	Carbon steel
20	1	Plug	Carbon steel

NOTE:

* Recommended spare parts

Figure 45. Assembly Kit

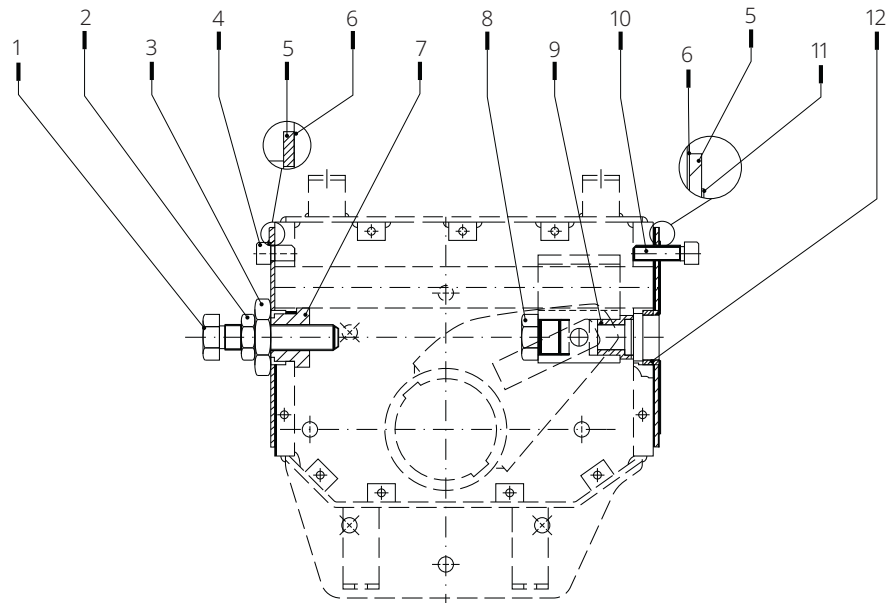

Table 25. Parts List

Item	Quantity	Description	Material
1	1	Screw	Alloy steel
2	1	Nut	Carbon steel
3	1	Nut	Carbon steel
4	4	Screw	Alloy steel
5	2	Flange	Carbon steel
6	2	Gasket	Fiber *
7	1	Stopper bush	Alloy steel
8	1	Plug	Alloy steel
9	1	Adaptor bush	Alloy steel
10	4	Screw	Alloy steel
11	1	Gasket	Fiber *
12	1	Washer	Alloy steel

NOTE:

* Recommended spare parts

Figure 46. Hydraulic Control Unit MHP

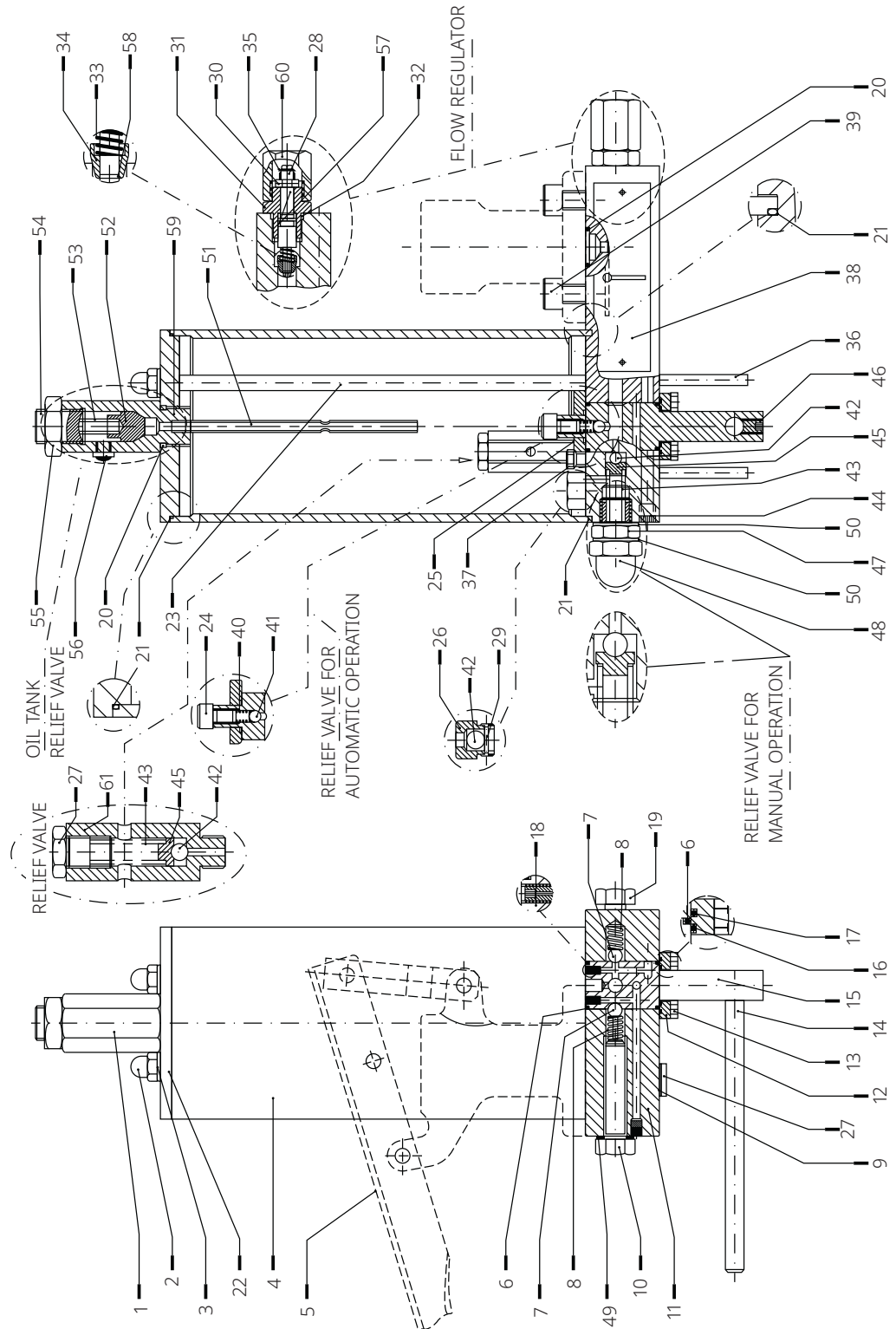
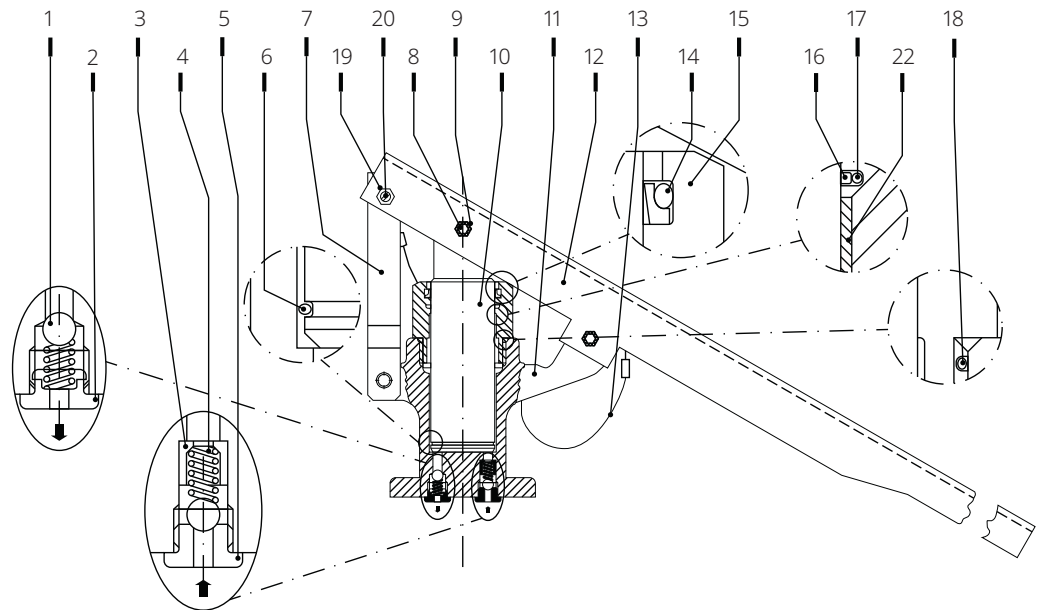

Table 26. Parts List

Item	Quantity	Description	Material
1	1	Dipstick	-
2	2	Cap nut	Carbon steel
3	2	Washer	Carbon steel + Rubber
4	1	Hydraulic tank	Carbon steel
5	1	Hand pump	See Table 27.
6	2	O-ring	Fluorosilicon rubber *
7	2	Ball	Stainless steel
8	2	Spring	Spring steel
9	1	Washer	Carbon steel + Rubber
10	1	Screw	Carbon steel
11	1	Plate	Carbon steel
12	1	Flange	Aluminum
13	4	Screw	Carbon steel
14	1	Lever	Carbon steel
15	1	Distributor	Stainless steel
16	1	O-ring	Fluorosilicon rubber *
17	1	O-ring	Fluorosilicon rubber *
18	1	Nozzle	Carbon steel
19	2	Screw	Carbon steel
20	3	O-ring	Fluorosilicon rubber *
21	2	O-ring	Fluorosilicon rubber *
22	1	Tank cover	Carbon steel
23	2	Tie rod	Carbon steel
24	1	Screw	Carbon steel
25	1	Flange	Aluminum
26	2	Check valve body	Aluminum
27	2	Plug	Carbon steel
28	2	Flow control valve setting screw	Stainless steel
29	2	Spring pin	Stainless steel
30	2	Nut	Carbon steel
31	2	Flange	Carbon steel
32	2	O-ring	Fluorosilicon rubber *
33	2	Spring	Spring steel
34	2	Plug	Stainless steel
35	2	Retainer ring	Spring steel
36	2	Spring pin	Carbon steel
37	4	Screw	Carbon steel
38	1	Operation instruction plate	Stainless steel
39	4	Screw	Carbon steel
40	1	Spring	Stainless steel
41	1	Ball	Stainless steel
42	4	Ball	Stainless steel
43	2	Spring	Spring steel
44	1	Relief valve setting screw	Stainless steel
45	2	Spring pin	Carbon steel
46	1	Screw	Alloy steel
47	1	Spring	Stainless steel
48	1	Nut	Carbon steel
49	1	Washer	Carbon steel + Rubber
50	2	Washer	Carbon steel + Rubber
51	1	Dipstick	Stainless steel
52	1	Plug + O-ring	Stainless steel + Fluorosilicon rubber *
53	1	Spring	Stainless steel
54	1	Screw	Alloy steel
55	1	Nut	Carbon steel
56	1	Silencer	Brass
57	2	O-ring	Fluorosilicon rubber *
58	2	Retainer ring	Spring steel
59	1	Dipstick body	Aluminum
60	2	Nut	Carbon steel
61	1	Relief valve body	Aluminum

NOTE:

* Recommended spare parts

Figure 47. Hand Pump**Table 27. Parts List**

Item	Quantity	Description	Material
1	2	Ball	Stainless steel
2	1	Delivery valve bush	Carbon steel
3	1	Suction valve bush	Carbon steel
4	2	Spring	Stainless steel
5	1	Suction valve ring	Carbon steel
6	1	Spring retainer ring	Carbon steel
7	1	Fork	Carbon steel
8	2	Pin	Stainless steel
9	4	Retainer ring	Carbon steel
10	1	Rod	Alloy steel
11	1	Body	Carbon steel
12	1	Lever	Carbon steel
13	1	Split pin with rope	Nylon + carbon steel
14	1	Scraper ring	PTFE + Fluorosilicon rubber *
15	1	Threaded bush	Aluminum
16	2	Rod seal ring	PTFE + Graphite *
17	2	O-ring	Fluorosilicon rubber *
18	1	O-ring	Fluorosilicon rubber *
19	1	Nut	Carbon steel
20	1	Screw	Carbon steel
21	1	Fork	Carbon steel
22	1	Piston rod bushing	Steel + Bronze + PTFE

NOTE:

* Recommended spare parts

Figure 48. Jackscrew Manual Override MSJ or MHW

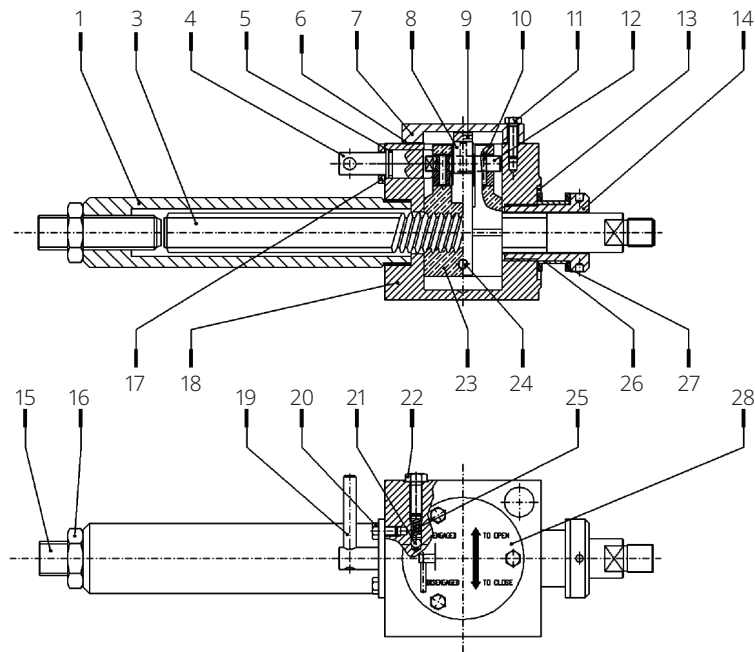

Table 28. Parts List

Item	Quantity	Description	Material
1	1	Protection pipe	Carbon steel
3	1	Jackscrew	Carbon steel
4	1	Engagement lever pin	Stainless steel
5	1	O-ring	Fluorosilicon rubber *
6	1	Cover gasket	Fiber *
7	1	Cover	Carbon steel
8	3	Cam	Alloy steel
9	1	Fork	Carbon steel
10	3	Spring pin	Stainless steel
11	3	Screw	Carbon steel
12	1	Screw nut operating cam	Alloy steel
13	1	O-ring	Fluorosilicon rubber *
14	1	Thrust nut operating cam	Alloy steel
15	1	Screw	Carbon steel
16	1	Nut	Carbon steel
17	1	Flange	Carbon steel
18	1	Body	Carbon steel
19	1	Spring pin	Spring steel
20	2	Screw	Carbon steel
21	1	Ball 1/4 in.	Stainless steel
22	1	Screw	Carbon steel
23	1	Screw nut	Bronze
24	1	Pin	Carbon steel
25	1	Spring	Spring steel
26	1	Bush	Bronze
27	2	Thrust shoulder washer	Bronze
28	1	Operating instruction plate	Aluminum

NOTE:

* Recommended spare parts

Section 8: Date Report for Maintenance Operations

Last maintenance operation date:	(in factory, on delivery):
 exec. by:
 exec. by:
 exec. by:
Next maintenance operation date: exec. by:
 exec. by:
 exec. by:
Start-up date: (in factory, on delivery).....
 (on plant).....

This page is intentionally left blank.

Biffi Italia s.r.l.
Strada Biffi 165
29017 Fiorenzuola d'Arda (PC)
Italy
T +39 0523 944 411

For complete list of sales and manufacturing sites, please visit
www.biffi.it or contact us at biffi_italia@biffi.it

VCIOM-03401-EN © 2025 Biffi. All rights reserved.

The contents of this publication are presented for informational purposes only, and while every effort has been made to ensure their accuracy, they are not to be construed as warranties or guarantees, express or implied, regarding the products or services described herein or their use or applicability. All sales are governed by our terms and conditions, which are available upon request. We reserve the right to modify or improve the designs or specifications of such products at any time without notice.

