

# GILS

## SPRING RETURN DIRECT GAS LINEAR ACTUATOR

**MAN 726**

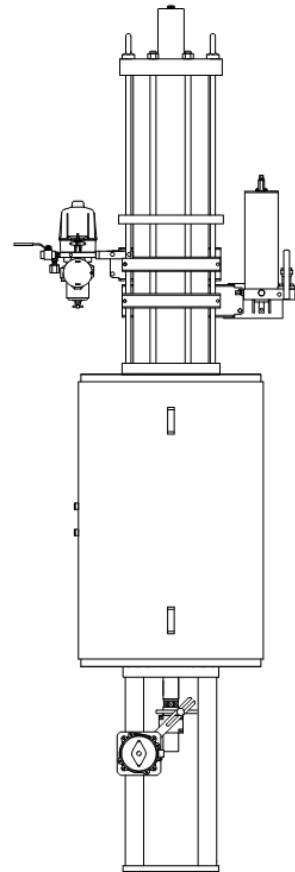

### Use and maintenance manual

1	18/04/16	Updated applicable regulation (chapter 1.1.1)	<i>Ermanni</i>	<i>Orefici</i>	<i>Vigliano</i>
0	09/11/15	Document release	<i>Ermanni</i>	<i>Orefici</i>	<i>Vigliano</i>
Rev.	Date	Description	Prepared	Checked	Approved

## **TABLE OF CONTENTS**

<b>1 General warnings .....</b>	<b>4</b>
1.1 GENERALITIES .....	4
1.1.1 <i>Applicable regulation</i> .....	4
1.1.2 <i>Terms and conditions</i> .....	4
1.2 Identification plate .....	5
1.3 INTRODUCING THE ACTUATOR .....	5
1.4 DATA SHEET .....	7
<b>2 Installation .....</b>	<b>7</b>
2.1 CHECKS UPON ACTUATOR RECEIPT .....	7
2.2 ACTUATOR HANDLING .....	8
2.3 STORAGE .....	9
2.4 ACTUATOR ASSEMBLY ON THE VALVE .....	9
2.4.1 <i>Types of assembly</i> .....	9
2.4.2 <i>Assembly procedure</i> .....	10
2.5 PNEUMATIC CONNECTIONS .....	13
2.6 ELECTRICAL CONNECTIONS (IF ANY) .....	14
2.7 COMMISSIONING .....	15
<b>3 Operation and use .....</b>	<b>16</b>
3.1 OPERATION DESCRIPTION .....	16
3.2 RESIDUAL RISKS .....	16
3.3 OPERATIONS .....	16
3.4 CALIBRATION OF THE linear STROKE .....	19
3.5 CALIBRATION OF MICROSWITCHES (applicable for BIFFI limit switch box* ONLY) .....	21
3.6 CALIBRATION OF THE OPERATION TIME .....	23
<b>4 Operational tests and inspections .....</b>	<b>24</b>
<b>5 Maintenance .....</b>	<b>25</b>
5.1 PERIODIC MAINTENANCE .....	25
5.2 EXTRAORDINARY MAINTENANCE .....	30
5.3 DISMANTLING AND DEMOLITION .....	32
<b>6 Troubleshooting .....</b>	<b>33</b>
6.1 FAILURE OR BREAKDOWN RESEARCH .....	33
<b>7 Layouts .....</b>	<b>34</b>
7.1 Spare parts order .....	34
7.2 parts-list for maintenance and replacing procedure .....	35
<b>8 Date report for maintenance operations .....</b>	<b>44</b>

**NOTE:**

*BIFFI Italia S.r.l. pays the highest attention to collecting and verifying the documentation contained in this user manual. However BIFFI Italia S.r.l. is not liable for any mistakes contained in this manual, for damage or accidents due to the use of the latter. The information contained is of exclusive reserved ownership of BIFFI Italia S.r.l and may be modified without prior notice. All rights reserved.*

# 1 General warnings



The manual is an integral part of the machine, it should be carefully read before carrying out any operation and it should be kept for future references.

## 1.1 GENERALITIES

BIFFI Italia S.r.l actuators are conceived, manufactured and controlled according to the Quality Control System in compliance with EN-ISO 9001 international regulation.

### 1.1.1 Applicable regulation

UNI EN ISO 12100-1: 2005: **Safety of machinery** – *Basic notions, general design principles. Part 1-Basic terminology, method.*

UNI EN ISO 12100-2: 2005: **Safety of machinery** – *Basic notions, general design principles. Part 2-Technical principles and specification.*

2006/42/EC: **Machine directive.**

97/23/EC: **Directive for pressure PED equipment** (until 18 July 2016) 2014/68/EU from 19 July 2016

2006/95/EC: **Directive for low voltage equipment** (until 19 April 2016) 2014/35/EU from 20 April 2016

2004/108/EC: **Directive for the electromagnetic compatibility** (until 19 April 2016) 2014/30/EU from 20 April 2016

94/9/CE: **Directive and safety instructions for use in hazardous area** (until 19 April 2016) 2014/34/EU from 20 April 2016

### 1.1.2 Terms and conditions





Biffi Italia srl guarantees that all the items produced are free of defects in workmanship and manufacturing materials and meet relevant current specifications, provided they are installed, used and serviced according to the instructions contained in the present manual. The warranty can last either one year from the date of installation by the initial user of the product, or eighteen months from the date of shipment to the initial user, depending on which event occurs first. All detailed warranty conditions are specified in the documentation forwarded together with the product. This warranty does not cover special products or components not warranted by subcontractors, or materials that were used or installed improperly or were modified or repaired by unauthorized staff. In the event that a

fault condition be caused by improper installation, maintenance or use, or by irregular working conditions, the repairs will be charged according to applicable fees. **The warranty and Biffi Italia srl liability shall lapse in the event that any modification or tampering whatsoever be performed on the actuator.**

## 1.2 IDENTIFICATION PLATE

It is forbidden to modify the information and the marks without previous written authorization by BIFFI Italia S.r.l.

The plate fastened on the actuator contains the following information (Figure1).

 <b>BIFFI</b>		BIFFI ITALIA Fiorenzuola D'Arda 29017 (PC) - ITALY	
ORDER	_____		
ACKNOW.	_____	S/N	_____
MODEL	_____		
CONSTR. YEAR	_____	FLUID	_____
ALLOWABLE TEMP. RANGE	_____		
MAX ALLOWABLE PRESSURE	_____		
SUPPLY PRESSURE RANGE	_____		
VALVE TAG	_____	ND	_____
		Reference	IP67M
		112GD135°C(T4)	DT2101 NEMA 4, 4X, 6

**Figure 1 – Data plate**

## 1.3 INTRODUCING THE ACTUATOR

GILS Spring return pneumatic high-pressure linear actuators, are suitable for the operation of linear valves ( wedge gate valves, through conduit gate valves) for ON-OFF and modulating heavy-duty service.

The actuator is made up of a pneumatic cylinder and a mounting pedestal complete with a joint for the coupling to the valve stem of actuator output stem. The valve is actuated in opening and in closing position by the actuator pneumatic cylinder that is pressurized in one direction and by Spring cartridge, in the other direction.

The spring module incorporates up to four springs, fully encapsulated in a factory-welded cartridge: this ensure safety to personnel and simplifies assembly. The linear stroke of the valve is adjustable by means of the external mechanical stop for upward position and by the adjustment of the coupling of valve stem to actuator joint for the downward position.

The actuator pedestal has a flange with threaded holes to fix the actuator to the valve.

BIFI can supply different types of control system following Customer's requirements.

The expected lifetime of actuator is approximately 25 years .

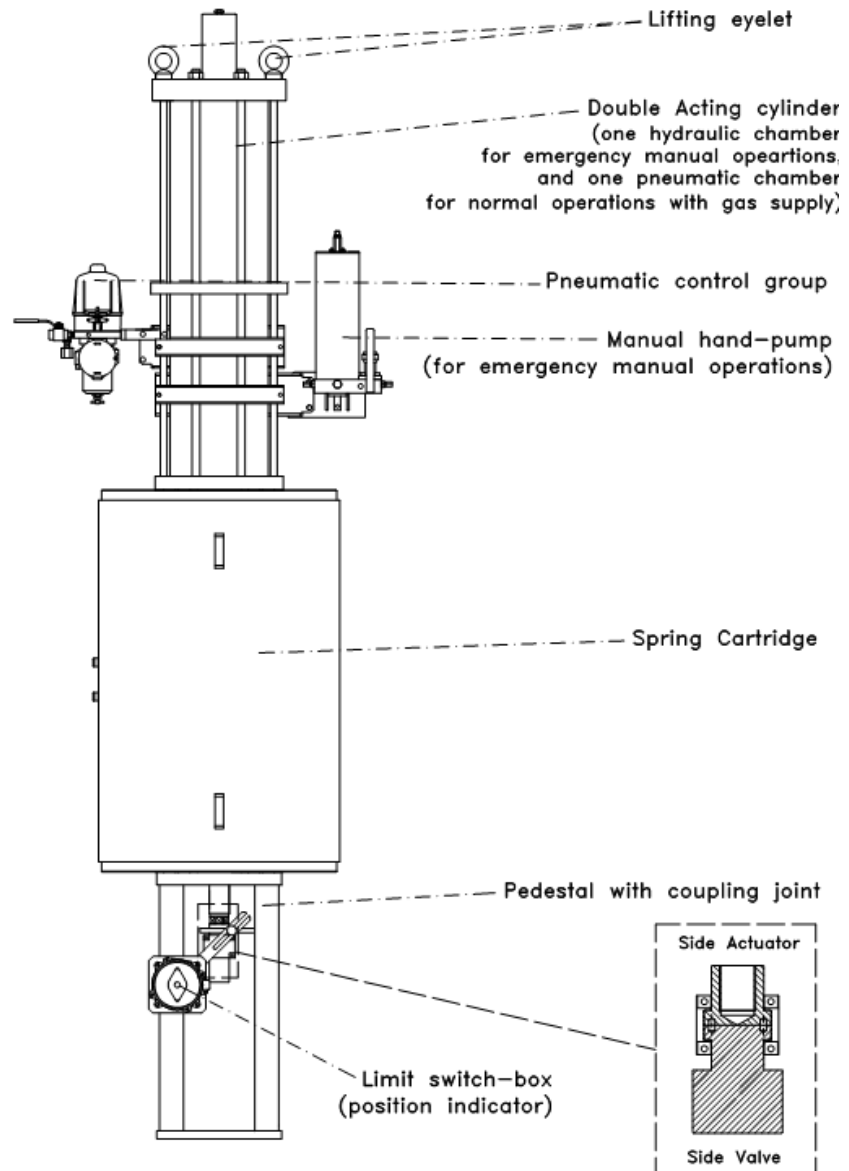

**Figure 2 – Identification of actuator parts – and actuator code :**

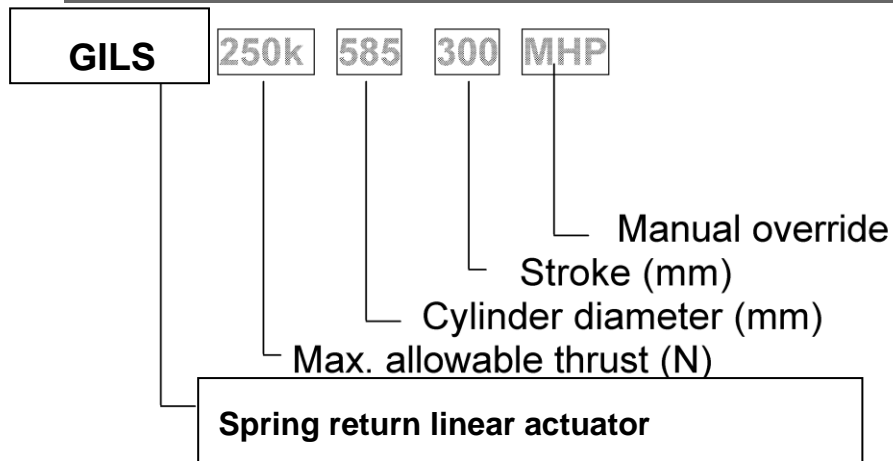

## 1.4 DATA SHEET

<b>Supply fluid</b>	Air, nitrogen or sweet gas
<b>Operating temperature</b>	Standard: from $-30^{\circ}\text{C}$ to $+100^{\circ}\text{C}$ Optional: from $-60^{\circ}$ to $+140^{\circ}\text{C}$
<b>Supply pressure</b>	From 10 to 105 bar g Maximum

# 2 Installation

## 2.1 CHECKS UPON ACTUATOR RECEIPT

- Check that the model, the serial number of the actuator and the technical data reported on the identification plate correspond with those of order confirmation (Sect. 1.2).
- Check that the actuator is equipped with the fittings as provided for by order confirmation.
- Check that the actuator was not damaged during transportation: if necessary renovate the painting according to the specification reported on the order confirmation.
- If the actuator is received already assembled with the valve, its settings have already been made at the factory.  
If the actuator is delivered separately from the valve, it is necessary to check, and, if required, to adjust, the settings of the mechanical stops (Sect. 3.4) and of micro-switches (if any) (Sect. 3.5).

## 2.2 ACTUATOR HANDLING



The lifting and handling should be made by qualified staff and in compliance with the laws and provisions in force.



The Lifting points are appropriate for the lifting of the actuator alone and not for the valve + actuator assembly.



Avoid that during the handling, the actuator passes above the staff.

The actuator should be handled with appropriate lifting means. The weight of the actuator is reported on the delivery bill.

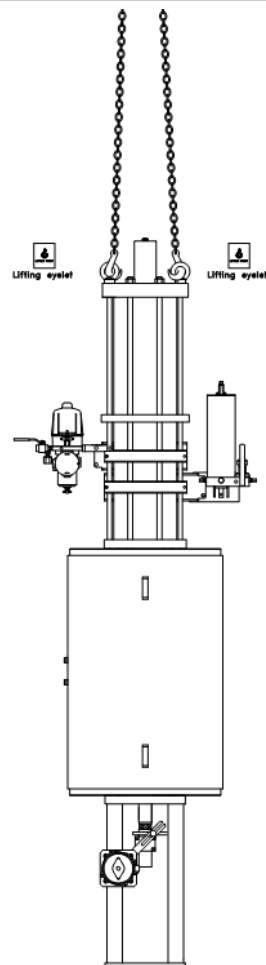

Picture 1 – Lifting points for GILS

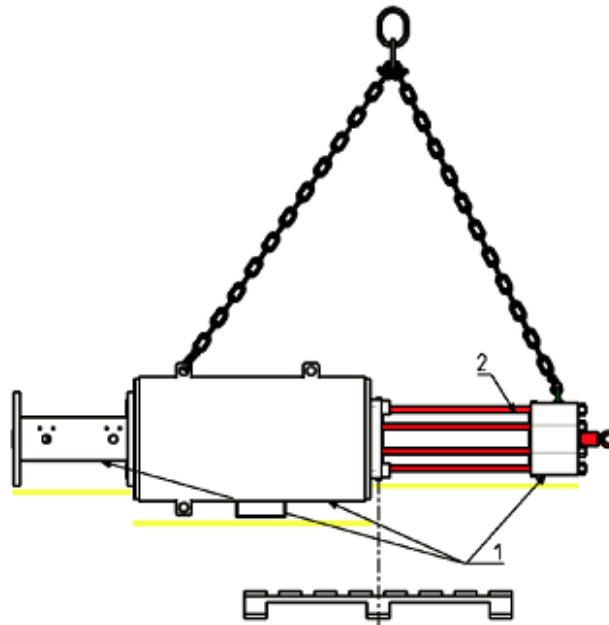

**Picture 2 - Positioning by chains**



- 1 = point of support - 2 = don't lay the actuator on tie-rods of cylinder  
 3 = don't lay the actuator on accessories ( manual hand-pump, hydraulic control system etc. )

## 2.3 STORAGE

If the actuator needs storage, before installation follow these steps:

- ❑ Place it on a wood surface in order not to deteriorate the area of valve coupling.
- ❑ Make sure that plastic plugs are present on the pneumatic and electrical connections (if present).
- ❑ Check that the cover of the control group and of the limit switch box (if any) are properly closed.

If the storage is long-term or outdoor:

- ❑ Keep the actuator protected from direct weather conditions.
- ❑ Replace plastic plugs of pneumatic and electrical connections (if any) with metal plugs that guarantee perfect tightness.
- ❑ Coat with oil, grease or protection disc, the valve coupling area.
- ❑ Periodically operate the actuator (Sect. 3.3).

## 2.4 ACTUATOR ASSEMBLY ON THE VALVE

### 2.4.1 Types of assembly

The adapter pedestal in fabricated carbon steel is specifically designed for adaptation to any type of valve with provision for local indicator, limit switches and other accessories (on request).

Lift the actuator by safety-hook for chains using the lifting-points (see sect. 2.2) on the top of actuator for handling, transporting and assembling in vertical position (see picture 1). For handling, transporting and assembling the actuator in horizontal position by safety-hook for chains use the lifting-points on the top of cylinder head-flange and on coupling flange (see picture 2).

#### **2.4.2 Assembly procedure**



**Failure to comply with the following procedures may impair product warranty. Installation, commissioning and maintenance and repair works should be carried out by qualified staff.**

**A non-conforming assembly could be the source of serious accidents.**

For actuator assembly on the valve:



**Check that the assembly position, as shown on the documentation, complies with system's geometry.**

**Check the consistency of the parts of actuator-valve coupling.**

***A) TO ASSEMBLE THE ACTUATOR ONTO THE VALVE BY BRACKET WITH THREADED JOINT PROCEED AS FOLLOWS:***

## PEDESTAL with THREADED COUPLING JOINT

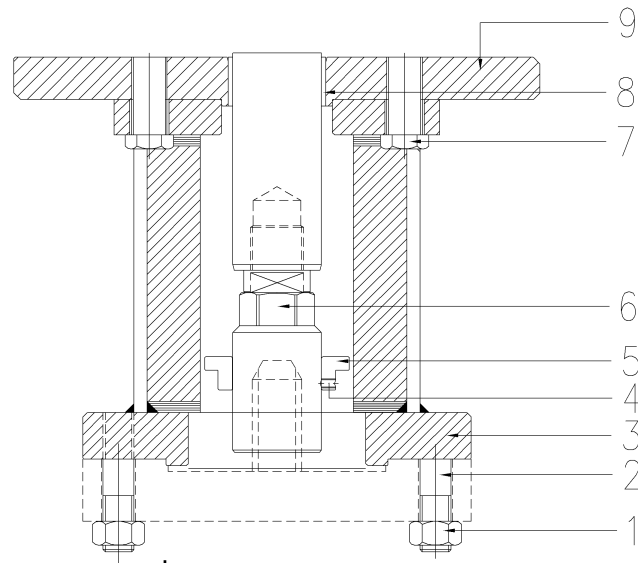

ITEM	DESCRIPTION
1	Nut
2	Stud bolt
3	Support joint
4	Index
5	Screw
6	Connecting joint
7	Screw
8	Bushing
9	Flange

- 1) Check that the coupling dimensions of the valve flange and stem, or of the relevant extension, meet the actuator coupling dimensions (valve stem and flange). Lubricate the valve stem with grease in order to make the assembly easier.
- 2) Connect a sling to the support point of the actuator and lift it. To make easier the assembly, the valve stem has to be in perfect vertical position.  
**Note:** *the eyebolt is sized for the lifting of the only actuator (NOT ACTUATOR+VALVE). Proper lifting points have to be foreseen for the valve.*
- 3) . Screw the actuator coupling joint onto the valve by rotating the actuator, or screw down the valve stem stroke-ring with Red Loctite 542 and fix the half-bearings. When the threaded holes of the actuator flange are in correspondence with the holes on the valve flange screw the proper stud bolts. Screw the nuts on the stud bolts and tighten up the valve flange is in contact with the actuator flange.
- 4) Tighten the nuts of the connecting stud bolts evenly with the torque prescribed in the table. The stud bolts must be made of ASTM A320 L7 steel, the nuts must be made of ASTM A194 grade 2 steel as minimum.

**B) To assemble the actuator onto the valve by bracket with shell joint, perform the following operations:**

PEDESTAL with SHELL COUPLING JOINT

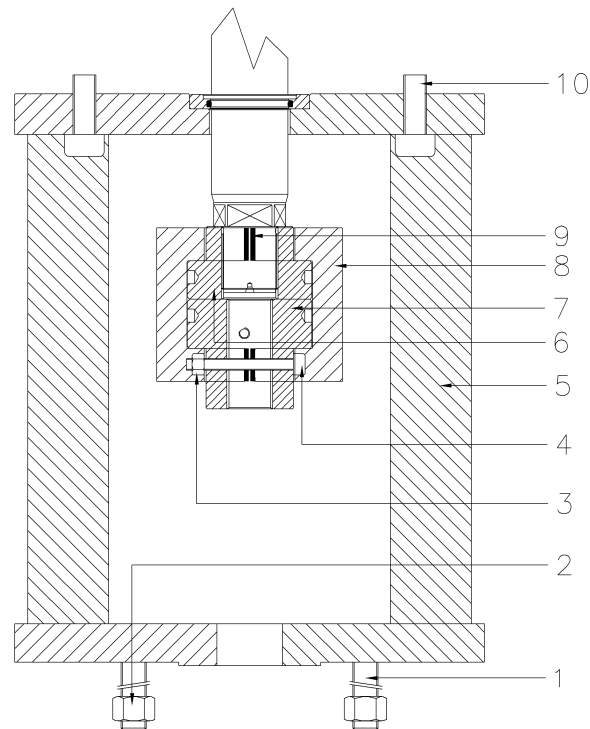

ITEM	DESCRIPTION
1	Stud bolt
2	Nut
3	Nut
4	Screw
5	Pedestal
6	Actuator joint
7	Stem valve joint
8	Shell joint
9	Spacer
10	Screw

- 1) -Check that the coupling dimensions of the valve flange and stem, or of the relevant extension, meet the actuator coupling dimensions (valve stem and flange). Lubricate the valve stem with grease in order to make the assembly easier
- 2) To make easier the assembly, the valve stem has to be in perfect vertical position.
- 3) -Disassemble the two halves of actuator pedestal shell joint (item 8) by unscrewing the retaining screws (item 4 ),therefore disassemble the valve stem joint (item 7).
- 4) -Lift the actuator by utilizing the proper lifting eyelets, and unscrew the nuts and the stud bolts from the actuator pedestal.
- 5) -Assemble the actuator onto the valve, and arrange it in its correct vertical position proper to connection between valve stem and actuator cylinder rod.

- 6) -Screw the valve stem joint (item 7) on valve stem up to reach the proper position which allow the reassembly of the two halves of shell joint (item 8), tighten the joint fastening screws (item 4).
- 7) -Screw the stud bolts (item 1) into the actuator pedestal flange, and screw the nuts on the stud bolts.
- 8) -Tighten according to the nut (item 2) size torque requirements.



To operate refer to following table:

Table 1: *nuts tightening torque*

<b>Threading</b>	<b>Tightening torque (Nm)</b>
M8	20
M10	40
M12	70
M14	110
M16	160
M20	320
M22	420
M24	550
M27	800
M30	1100
M33	1400
M36	1700

The screwing values in Table 1 were calculated considering the materials ASTM A320 L7 for screws or tie rods and ASTM A194 gr.2H for the nuts.

## 2.5 PNEUMATIC CONNECTIONS



**Check that the values of pneumatic supply available are compatible with those reported on the identification plate of the actuator.**

**The connections should be made by qualified staff.  
Use pipes and connections appropriate as for type, material and dimensions.**

- ❑ Properly de-burr the ends of rigid pipes
- ❑ Properly clean the interior of pipes sending through them plenty of the supply fluid used in the system.
- ❑ Mould and fasten the connection pipes so that no irregular strains at entries or loosening of threaded connections occur.
- ❑ Make the connections according to the operating diagram.
- ❑ Check the absence of leakages from pneumatic connections.

## 2.6 ELECTRICAL CONNECTIONS (IF ANY)



**Use components appropriate as for type, material and dimensions**

**The connections should be made by qualified staff  
Before carrying out any operation, cut line power off**

**Safety provisions :**



**2006/95/EC: Directive for low voltage equipment (until 19 April 2016) 2014/35/EU from 20 April 2016**

**2004/108/EC: Directive for the electromagnetic compatibility (until 19 April 2016) 2014/30/EU from 20 April 2016**

**94/9/CE: Directive and safety instructions for use in hazardous area (until 19 April 2016) 2014/34/EU from 20 April 2016**

Remove plastic plugs from cables entries

- ❑ Screw firmly the cable glands.
- ❑ Introduce connection cables.
- ❑ Make the connections in compliance with applicable wiring diagrams on the documentation supplied.
- ❑ Screw the cable gland.
- ❑ Replace the plastic plugs of unused entries with metal plugs.



Picture 2 – Junction box on Control group

## 2.7 COMMISSIONING



**Installation, commissioning and maintenance and repair works should be made by qualified staff.**

Upon actuator commissioning please carry out the following checks:

- ❑ Check that paint is not be damaged during transport, if necessary repair the damages to paint coat.
- ❑ Check that the pressure and quality of the gas supply (filtering degree, dehydration) are as prescribed. Check that the feed voltage values of the electric components (solenoid valve coils, micro-switches, pressure switches, etc.) are compatible with those reported on the identification plate of the actuator (Figure 1).
- ❑ Check that the setting of the components of the actuator control unit (pressure regulator, pressure switches, flow control valves, etc.) meet the plant requirements.
- ❑ Carry out all kinds of operations and check their proper execution (Sect. 3.3).
- ❑ Check the absence of leakages in the pneumatic connections. If necessary tighten the nuts of the pipe-fittings
- ❑ Check proper operation of all the due signalling ( valve position, gas supply pressure etc. )
- ❑ Make a complete functional test in order to verify all the operations are executed according to operating schematic diagram supplied.

## **3 Operation and use**

### **3.1 OPERATION DESCRIPTION**

In the normal operating situation, the direct gas actuator is fed by pressurised gas which flows into pneumatic cylinder. The cylinder piston stroke causes the actuator operation and the consequent linear valve movement to the operational position requested (for example to the “open” position).

Upon a demand, the gas is discharged from the cylinder into the return line: the actuator performs the closing operation driven by the spring movement, and the valve moves from the open position to the close (safety-related) position

For local or remote operations, please refer to technical documentation furnished with actuators.

The power and control systems are supplied on specific customer demand.

**For all the relevant information please refer to the specific documentation supplied.**

### **3.2 RESIDUAL RISKS**



**It is recommended to pipe exhaust gas.**

**The actuator has parts under pressure.**

**Use the due caution.**

**Use individual protections provided for by the laws and provisions in force.**

### **3.3 OPERATIONS**



**Use the proper safety measures to protect from any pressurised gas not piped and from excessive and harmful noise. Refer to applicable control schematic in supplied documentation.**

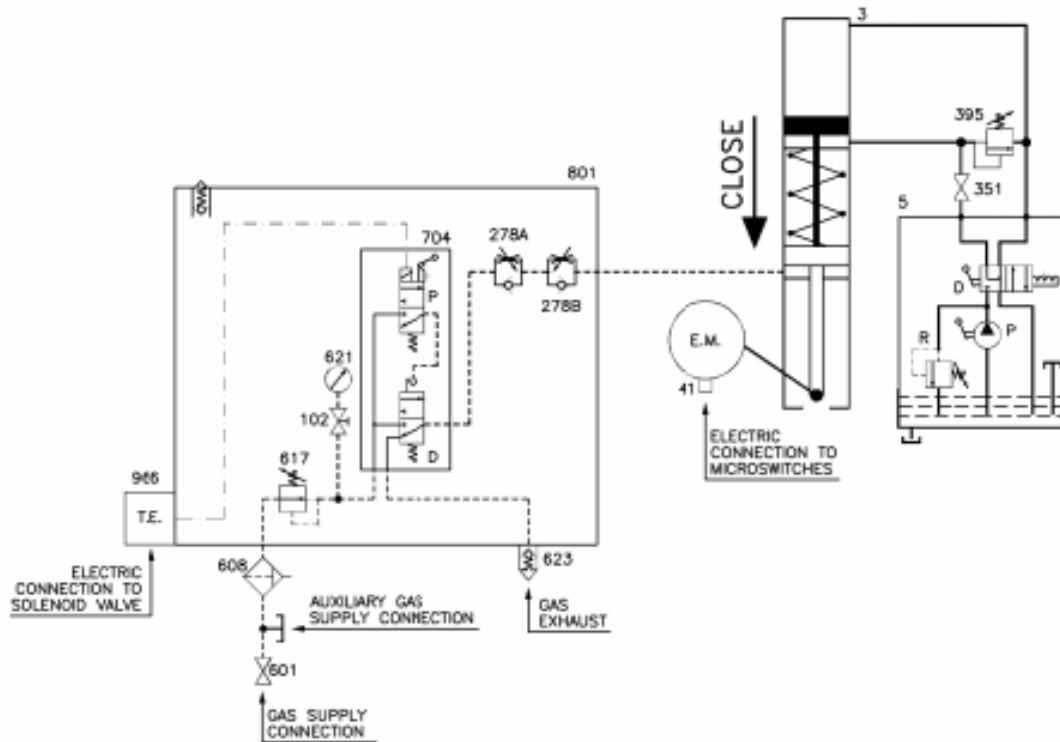

**ELECTRIC REMOTE CONTROL TO OPEN**  
 ENERGIZE PERMANENTLY THE SOLENOID VALVE 704-P.  
 THE OPENING TIME IS ADJUSTABLE BY THE FLOW REGULATOR 278B.

**ELECTRIC REMOTE CONTROL TO CLOSE**  
 DE-ENERGIZE THE SOLENOID VALVE 704-P.  
 THE CLOSING TIME IS ADJUSTABLE BY THE FLOW REGULATOR 278A.

**LOCAL CONTROL TO OPEN AND TO CLOSE**  
 PRESS AND LOCK THE LEVER ON VALVE 704-P TO OPEN WITH  
 GAS SUPPLY.  
 RELEASE THE LEVER ON VALVE 704-P TO CLOSE.

**EMERGENCY MANUAL OPERATION**  
 TO OPEN: SELECT BY THE VALVE "5-D" THE "MANUAL CONTROL"  
 OPERATION AND ACTUATE THE HAND PUMP "5-P".  
 AT THE END OF OPENING OPERATION CLOSE THE VALVE 351.  
 TO CLOSE: OPEN THE STOP VALVE 351 AND SELECT BY THE  
 VALVE "5-D" THE "AUTOMATIC CONTROL" OPERATION.  
 NOTE: THE VALVE "5-D" MUST BE IN "AUTOMATIC CONTROL"  
 POSITION AND THE STOP VALVE 351 MUST BE OPEN TO  
 ALLOW THE OPERATION WITH GAS SUPPLY.



- 1 SINGLE ACTING SPRING RETURN PNEUMATIC LINEAR ACTUATOR
- 3 HYDRAULIC CYLINDER
- 5 MANUAL OVERRIDE
  - R - RELIEF VALVE
  - P - HAND PUMP
  - D - HAND OPERATED DIRECTIONAL CONTROL VALVE
- 41 ELECTRIC MICROSWITCHES
- 102 NEEDLE VALVE
- 278 UNIDIRECTIONAL FLOW REGULATOR (ADJUSTABLE SETTING)
- 395 RELIEF VALVE
- 351 STOP VALVE
- 601 STOP VALVE
- 608 GAS FILTER/CONDENSATE SEPARATOR
- 617 PRESSURE REGULATOR
- 621 PRESSURE GAUGE
- 623 DUST EXCLUDER WITH CHECK VALVE
- 704 3/2 N.C. SOLENOID VALVE WITH MANUAL OVERRIDE
- P - 3/2 N.C. PILOT SOLENOID VALVE WITH MAN.OVERR.
- D - 3/2 N.C. PNEUM. PILOT/SPRING RETURN VALVE
- 801 CONTROL VALVES ENCLOSURE WITH VENT VALVE
- 966 TERMINALS ENCLOSURE

**NOTE:**  
 THE DIAGRAM IS DRAWN WITH SOLENOID VALVES COILS NOT ENERGIZED.

----- PNEUMATIC CONNECTION -----

----- HYDRAULIC CONNECTION -----

----- ELECTRIC CONNECTION -----

Rev.	Date	By	Approved	Description
AutoCod 2000	Path T:\scp			
 <b>BIFI</b>				<b>"GILS" SINGLE ACTING                  SPRING TO CLOSE                  DIRECT GAS LINEAR ACTUATOR                  -OPERATING DIAGRAM-</b>
			Drawing Number <b>SRAAE009</b>	
		File SRAAE009	Date 09/11/15	
		By 	Approved 	

**Picture 5 – GILS – Typical operating diagram**

### ***Local pneumatic operation***



**Use the proper safety measures to protect from any pressurised gas not piped and from excessive and harmful noise.**

- ❑ Press and lock the manual control lever of solenoid valve 704P in the control group to operate (open) valve with gas supply (Picture 5),
- ❑ Check the correct operation of the actuator through the visual position indicator.
- ❑ Release the lever to operate by spring-cartridge in the opposite way to fail-safe position (closed)

### ***Electric remote control to open and to close***

- ❑ From control room send the electric signal, energize permanently the solenoid valve 704-P to operate actuator in opening direction, during all the valve stroke.
- ❑ The opening time is adjustable by flow regulator 278B.
- ❑ De-energize the solenoid valve 704-P, the actuator moves to fail safe position (closed).
- ❑ The closing time is adjustable by flow regulator 278A.

### ***Emergency manual operation ( when sufficient line pressure is not available )***

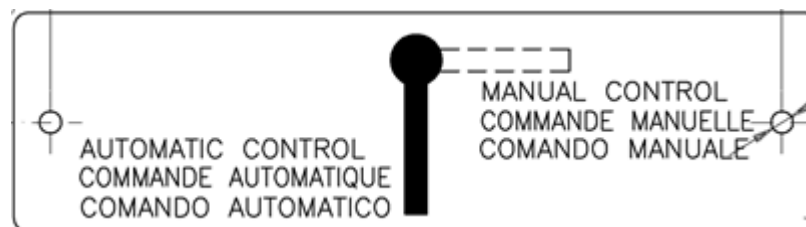

- ❑ **TO OPEN:** Select by the valve 5-D the “Manual control” operation.
- ❑ Actuated the pump 5-P until to reach the complete OPEN position
- ❑ Check the correct operation of the actuator through the visual position indicator.
- ❑ Close the stop valve 351 to keep the actuator in OPEN position.
- ❑ **TO CLOSE:** Open the stop valve 351 and select by the valve 5-D the “Automatic control” operation.



**If no other manual operation is carried out, the valve 5-D must be in “Automatic control” position and the stop valves 351 must be open to allow the operation with gas supply.**

(see chapt.7.2 table 5: sectional drawing for hydraulic control unit MHP)

### **3.4 CALIBRATION OF THE LINEAR STROKE**

It is important that the mechanical stops of the actuator (and not those of the valve) stop the linear stroke at both extreme valve position (fully open and fully closed), except when this is required by the valve operation).

The setting of the open valve position (upward position) is performed by adjusting the travel stop screw into the end flange of the pneumatic cylinder and by the adjustment of the coupling of valve stem to actuator joint for the downward position.

For the adjustment of the travel stop screws proceed as follows :

- 1) Unscrew the plug from the “adjusting screw cover”
- 2) If the actuator linear stroke is stopped before reaching the upward position (fully open or closed), unscrew the adjusting screw by turning it anticlockwise with a proper wrench , until the valve reaches the right position. When unscrewing the adjustable screw, keep the “adjusting screw cover still with a wrench so it does not withdraw together with the screw.
- 3) If the actuator linear stroke is stopped beyond the upward position (fully open valve), screw the stop screw by turning it clockwise until the valve reaches the right position.
- 4) Screw the plug into the “adjustable screw cover”.



**Picture 6 – Mechanical stop**

For the adjustment of the mechanical stop ,that is placed on the end flange of cylinder, follow these steps (Figure 7):

- ❑ Remove with the specific wrench (c1) the plug (t).
- ❑ Insert a wrench for Allen keys (c2) in the through hole until reaching the adjustment pin (g).
- ❑ Keep the protection cover blocked with the special wrench (c3).
- ❑ Turn counter-clockwise to increase the angular stroke, turn clockwise to decrease it.
- ❑ When the adjustment is over tighten the plug (t).

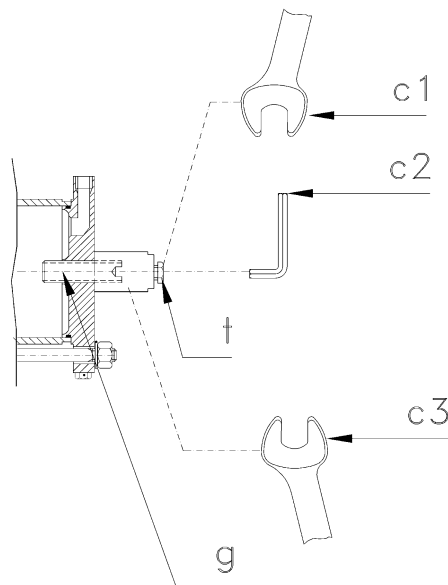

**Picture 7 – Mechanical-stopper on cylinder**

CYLINDER SIZE	WRENCH C1 (mm)	WRENCH C2 (mm)	WRENCH C3 (mm)
075	22	10	36
100	22	10	36
135	22	10	36
175	22	14	46
200	27	14	46
235	27	17	65
280	27	17	65
300	36	17	110

### 3.5 CALIBRATION OF MICROSWITCHES (APPLICABLE FOR BIFFI LIMIT SWITCH BOX\* ONLY)



**\*If different micro-switches assembly or limit switch box is supplied, please refer to the specific documentation supplied.**



**Operate only the micro-switch corresponding to the direction of operation being carried out, as clearly reported on the micro-switch.**

Micro-switches are placed inside a special box (Picture 9).

For micro-switches calibration please refer to the relative wiring diagram and follow these steps:

- ❑ Unscrew the fastening screws of the cover (Picture 9).
- ❑ Remove the cover paying attention not to deteriorate the gasket and the cylindrical and flat coupling surfaces.
- ❑ Operate the actuator (in opening or closing) with local pneumatic or hydraulic operation (Section 3.3)
- ❑ Unscrew the screw of the operating cam relative to the micro-switch to calibrate and adjust it according to the settings (Picture 10).
- ❑ Tighten the screw.
- ❑ Operate the actuator and adjust any other micro-switch with the procedure already described.
- ❑ Position the cover making sure the cam-carrier shaft grips with the index dragging shaft.
- ❑ Check that the cover and the index show the proper position of the valve (Picture 11).
- ❑ Tighten the screws.



**Picture 9 – Micro-switches box**

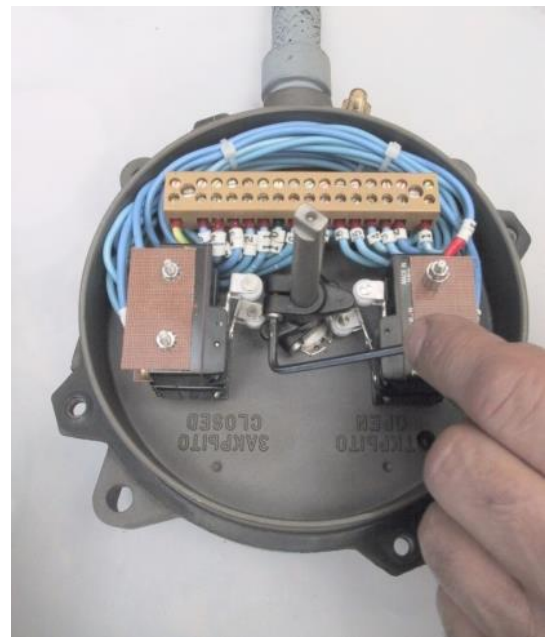

**Picture 10 – Cam adjustment**

If the index (Picture 11), does not signal the proper position of the valve but is turned by 90°:

- Remove the roll pin placed on the position indicator (index).
- Turn the indicator until reaching its proper positioning.
- Put the roll pin back in its position.



**End of stroke micro-switches should be operated before the stop of the stroke of the actuator due to mechanical stops. Adjust the relative cams properly.**

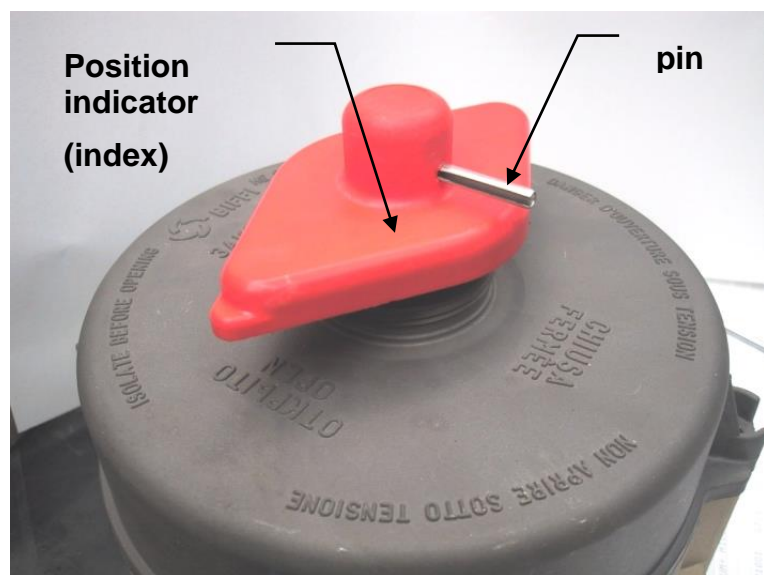

**Picture 11 – Position indicator and pin for micro-switches box**

### 3.6 CALIBRATION OF THE OPERATION TIME

The calibration of the operation time is made by Biffi Italia S.r.L according to customer requirements and to technical data-sheet included in technical documentation. If necessary it's possible to modify or reset the operating time through two flow regulation valves placed between the control valves enclosure and the pneumatic cylinder (Picture 12).

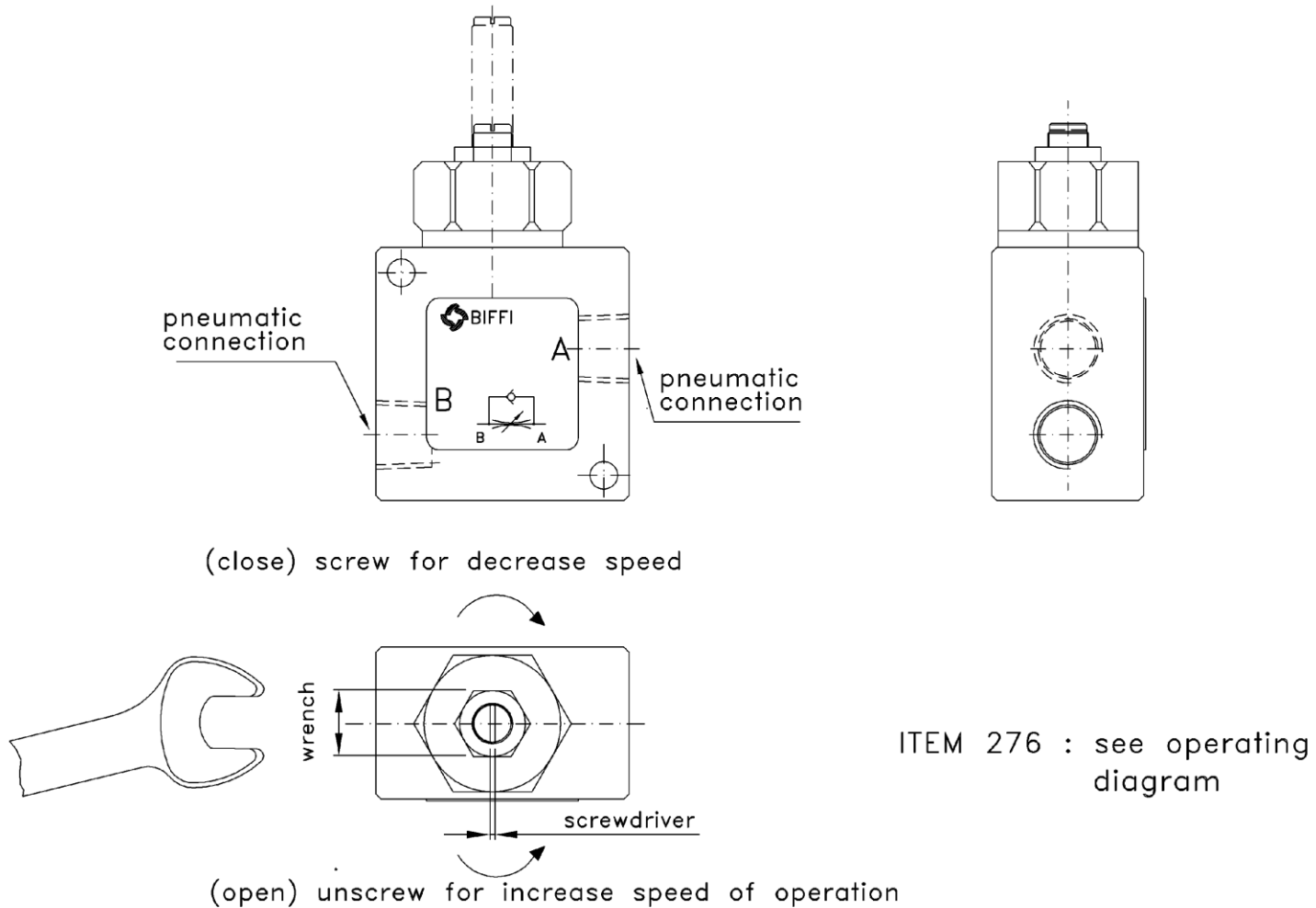

**Picture 12 – Adjustment of operation time**

## 4 Operational tests and inspections

**Important:** To ensure the guaranteed SIL grade, according to IEC 61508, the functionality of actuator must be checked with regular intervals of time, as described in the Safety Manual



## 5 Maintenance



**Before executing any maintenance operation, it is necessary to intercept the supply line and discharge pressure from the cylinder of the actuator, to take it to fail safe position, with the spring totally extended**



**Installation, commissioning and maintenance and repair works should be carried out by qualified staff.**

### 5.1 PERIODIC MAINTENANCE

GILS actuators are designed to operate long-term in heavy-duty operating conditions, without maintenance needs.

**Periodicity and regularity of inspections is particularly influenced by specific environmental and working conditions.**



**They can be initially determined experimentally and then be improved according to actual maintenance conditions and needs.**

Anyway every 2 years of operation the following is recommended:

- Check that the actuator operates the valve correctly and with the required operating times. If the actuator operation is very infrequent, carry out a few opening and closing operations with all the existing controls (remote control, local control, emergency controls, etc.), if this is allowed by the conditions of the plant.
- Check there are no hydraulic or pneumatic leakages.
- Check oil level (Pict. 13) into the hydraulic manual hand-pump, if present (see chapt. 5.1.1)
- Check the actuators did not undergo accidental damage with oil leakages found on site (Sect. 4.1.1).
- Check that improper closing of control-group cover did not produce the presence of condensation on it.
- Check the integrity of worn out parts (gaskets, pads etc.).
- Replace, if any, the mechanical filter of the supply gas (refer to chapt. 5.1.2)



**Picture 13 – Level measuring stick**

### **5.1.1 Check and restore oil level in the hydraulic manual handpump ( refer to chapt. 7.2 table 5 )**

Operate the distributor lever to “ manual control” operation.

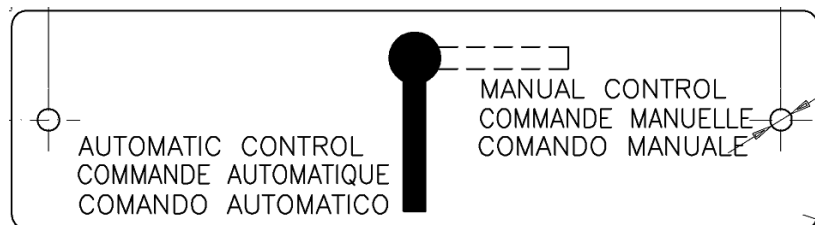

Move the actuator into his “fail to close” position.

Unscrew the dipstick (1).

Check that the oil level into the tank (4) is in correspondence of the “MAX LEVEL” notch of the dipstick.

Screw and tighten the dipstick.

If necessary substitute or added the oil, proceeding as follow:

- ❑ Remove the dipstick (1) from the tank cover (22).
- ❑ Unscrew the plug (27) and the washer (9) to drain all the oil.
- ❑ If some dirt or/and sludge is found in the oil drained from the tank, before filling with new oil in the tank, disassemble the oil tank tube, by unscrewing the two cap nuts (2), and clean the internal surfaces of the tank. If necessary substitute the gaskets (21) of the tank.
- ❑ Replace the plug (27) and the washer (9) into the plate (11) and tighten.
- ❑ Pour the new oil into the tank through the dipstick hole (1) on the cover (22).
- ❑ Replace the dipstick (1).
- ❑ Add oil (refer to Table 2) if in the tank the oil level is BELOW THE MINIMUM (Picture 13: minimum level is in correspondence to the end of dipstick ) until to reach the optimal (MAXIMUM) oil level .
- ❑ Operate the distributor lever to “AUTOMATIC CONTROL” position

*Table 2: features of hydraulic oil suggested by BIFFI Italia S.r.l*



**For refill use oil of the same brand as the one in the tanks.**

**Standard temperature conditions (-30°C/+85°):**

Producer	AGIP
Name	ARNICA 22
Viscosity at 40° C	20.9 mm <sup>2</sup> /s
Viscosity at 100° C	4.73 mm <sup>2</sup> /s
Viscosity index ASTM	153
Flash point	192° C
Pour point	-42° C
Specific weight (at 15°C)	0,857 Kg/l

**Equivalent oils:**

SHELL TELLUS PLUS 22  
 CHEVRON HYDRAULIC OIL AW ISO 22  
 MOBIL DTE22  
 EXXON UNIVIS N22  
 EQUIVIS ZS22  
 BP ENERGOL HLP-HM22  
 CASTROL DYSPIN AWS22

**Low temperature conditions (down to -46°C):**

Manufactured	<b>SHELL</b>
Name	<b>AEROSHELL FLUID 41</b>
Viscosity at -54° C	<b>2300 cST</b>
Viscosity at -40° C	<b>491 cST</b>
Viscosity at 40° C	<b>14,1 cST</b>
Viscosity at 100° C	<b>5,30 cST</b>
Viscosity index (ISO 2909)	<b>&gt;200</b>
Flash point	<b>105° C</b>
Pour point	<b>&lt;-60° C</b>
Specific weight	<b>0,87 Kg/dm<sup>3</sup></b>

**(or equivalent)**

**Low temperature conditions (down to -60°C):**

Manufactured Name	<b>SYNTESIS SYNTRASS-CS 500</b>
Viscosity at -60° C	<b>580 cST</b>
Viscosity at -30° C	<b>39cST</b>
Viscosity at 20° C	<b>5,8 cST</b>
Viscosity at 50° C	<b>2,1 cST</b>
Flash point	<b>152° C</b>
Pour point	<b>-68° C</b>
Specific weight	<b>0,897 Kg/dm3</b>

**(or equivalent)**

**5.1.2 Gas supply dehydrating filter maintenance (if foreseen)**

The gas supply filter is fitted with a mechanical filter and a drain valve to discharge periodically the water generated by the condensation of the humidity inside the gas supply.

During the routine maintenance it is recommended to check and clean the mechanical filter and replace it in case of heavy dirty conditions.

To disassemble the filter proceed as follow:

- close the stop valve at the inlet of pressure supply line;
- discharge the pressure from the drain valve;
- Remove the lower enclosure screws,
- remove the mechanical filter;
- clean or replace the filter;

reinstall all parts carefully paying attention to avoid any damage to the O-ring

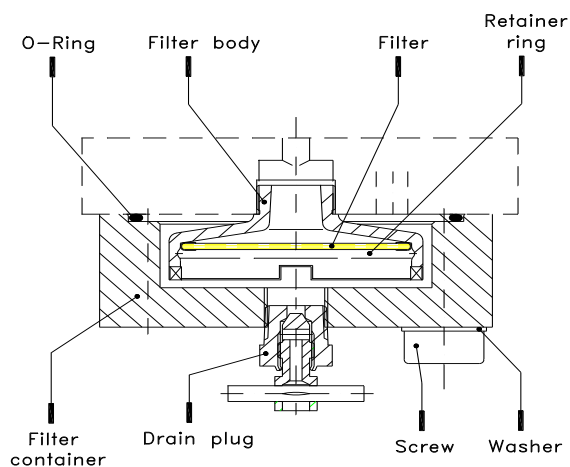

### 5.1.3 Lubrication of actuator

For normal duty the GIL actuator is lubricated "for life".

In case of high load and high frequency of operation it may be necessary to periodically restore lubrication: it is advisable to apply a generous coating of grease on the contact surfaces of moving parts.

The following grease is used by BIFFI for standard working temperature and suggested for re-lubrication:

<b>AGIP MU/EP/2</b>	<b>AEROSHELL GREASE 7 or equivalent</b>
<p>To be used in standard temperature conditions (-30°C/+85°C)</p> <p>NLGI consistency: 2</p> <p>Worked penetration: 280 dmm</p> <p>ASTM Dropping Point: 185°C</p> <p>Base oil viscosity at 40°C: 160 mm<sup>2</sup>/s</p> <p>ISO Classification: L-X-BCHB 2</p> <p>DIN 51 825: KP2K – 20</p> <p>Equivalent to: ESSO BEACON EP2 BP GREASE LTX2 SHELL ALVANIA GREASE R2 ARAL ARALUB HL2 CHEVRON DURALITH GREASE EP2 CHEVRON SPHEEROL AP2 TEXACO MULTIFAK EP2 MOBILPLEX 47 PETROMIN GREASE EP2</p>	<p>To be used in low temperature conditions (-60°C/+65°C)</p> <p>Colour: Buff</p> <p>Physical state: Semi-solid at ambient temperature</p> <p>Odour : Slight</p> <p>Density : 966 Kg/m<sup>3</sup> at 15°C</p> <p>Flash Point : &gt;215°C (COC)(Based on synthetic oil)</p> <p>Dropping point : 260°C (ASTM D-566)</p> <p>Product code : 001A0065</p> <p>Infosafe No.: ACISO GB/eng/C</p>

## 5.2 EXTRAORDINARY MAINTENANCE

If there are leakages to double cylinder, or a malfunction in the mechanical components, or in case of scheduled preventive maintenance, the actuator must be disassembled and seals must be replaced with reference to the follow general sectional drawing and adopting the following procedures:

### 5.2.1 Replacement of cylinder seals (refer to applicable table 1A )

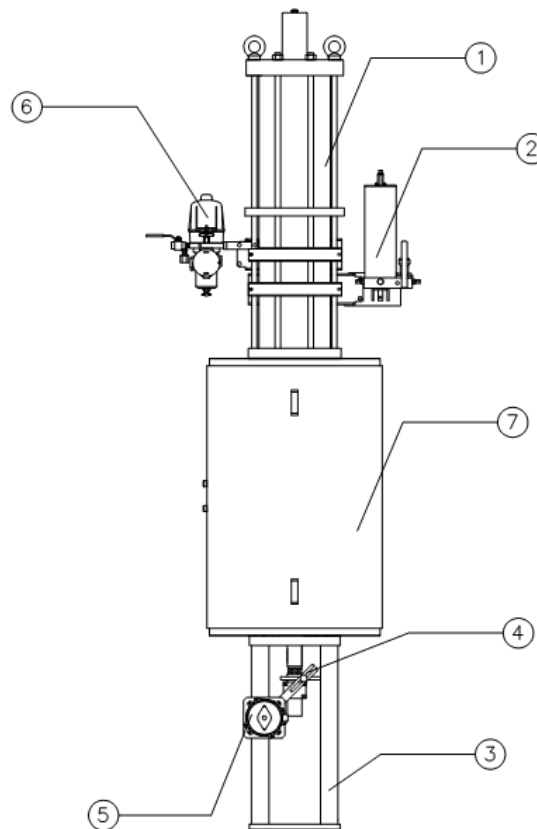

ITEM	Q.ty	DESCRIPTION	REFERENCE TABLE FOR MAINTENANCE OPERATIONS
1	1	CYLINDER GAS-HYDRAULIC	TABLE 1 A
2	1	EMERGENCY MANUAL HAND-PUMP	TABLE 2 B
3	1	PEDESTAL WITH COUPLING JOINT	TABLE 3 C
4	1	MOUNTING KIT FOLR LIMIT SWITCH BOX	TABLE 4 D
5	1	LIMIT SWITCH BOX	refer to model-catalogue
6	1	PNEUMATIC CONTROL GROUP	TABLE 6 F
7	1	SPRING CARTRIDGE	TABLE 7 G



**Before executing any maintenance operation, it is necessary to intercept the supply line and discharge pressure from the cylinder of the actuator, to take it to fail safe position, with the spring totally extended**

- 1) Unscrew the plug (18) from the adjusting screw cover (17).
- 2) Remove the adjusting screw cover (17) together with O-ring (20).
- 3) Measure the distance of the protrusion of adjusting screw (14) with reference to the end flange (22) surface, so as to be able to easily

restore the setting of the actuator mechanical stop, once the maintenance procedures have been completed.

- 4) Loosen the stop screw (14) until it is removed from the end flange (13)
- 5) Unscrew the nuts (15) from the tie rods (16) from the side of the end flange: they must be gradually unscrewed all at the same time.
- 6) Slide off the end flange (13) and the tube (10).

### *Seals replacement*

Prior to reassemble check that the actuator components are in good conditions and clean. Lubricate all the surfaces of the parts, which move in contact with other components, by recommended oil (SHELL Omala S4 WE 320 or equivalent). If the O-ring must be replaced, remove the existing one from its groove, clean the groove carefully and lubricate it with protective oil. Assemble the new O-ring into its groove and lubricate it with a protective oil.

- 1) Replace the O-ring (5) of the head flange (1).
- 2) Replace the O-ring (5) and the guide sliding ring (8) of the piston(7)  
Replace the O-ring (5) of the end flange (13).
- 3) Remove the O-ring (20) from the stop screw cover (17). Carefully clean and lubricate the stop screw thread and the surface of the end flange area, on which the sealing works.
- 4) Screw the new sealing onto the stop screw

### *Reassemble*

- 1) Carefully clean the inside of the tube (10) and check that the entire surface, particularly that of the bevels, is not damaged. Lubricate the inside surface of the tube and the bevels at the ends. Slide the tube onto the piston taking care not to damage the piston O-ring (5) and the head flange O-ring (5).
- 2) Assemble the end flange by centring it on the inside diameter of the tube, taking care not to damage the O-ring (3) and the seal ring (4).
- 3) Assemble the the nuts (15) onto the tie rods (16). Tighten the nuts to the recommended torque, alternating between opposite corners.
- 4) Screw the stop screw (14) into the threaded hole of the end flange until it reaches its original position (the same protrusion with reference to the flange surface). To make the operation easier feed the pneumatic cylinder with air (if possible) in order to move the piston
- 5) Tighten the adj. screw cover (17) and the plug (18).



Carry out a few operations (Sect. 3.3) to check there are no leakages from the gaskets.

### 5.3 DISMANTLING AND DEMOLITION



Before disassembling the actuator it is necessary to close the pneumatic supply line and discharge pressure from the cylinder of the actuator, from the control unit and from the accumulator tank, if present.

The demolition of the actuator both concerning any electrical and mechanical parts should be made by specialized staff

Before starting the disassembly a large area should be created around the actuator so to allow any kind of movement without problems of further risks created by work-site.



Separate the parts composing the actuator according to their nature (ex. metallic, and plastic materials, fluids etc.) and send them to differentiated waste collection sites, as provided for by the laws and provisions in force.

## 6 Troubleshooting

### 6.1 FAILURE OR BREAKDOWN RESEARCH

<b>Event</b>	<b>Possible cause</b>	<b>Remedy</b>
<b>Actuator does not work</b>	Lack of power supply	Restore it
	Lack of pneumatic supply	Open line interception valve
	Blocked valve	Repair or replace
	Wrong position of the distributor of the hydraulic manual override	Restore correct position
<b>Actuator too slow</b>	Failure of the control system	Call BIFFI Italia S.r.l. Customer Service
	Low supply pressure	Restore (Sect. 1.4)
	Wrong calibration of flow regulator valves	Restore (Sect. 3.6)
<b>Actuator too fast</b>	Wear of the valve	Replace
	High supply pressure	Restore (Sect. 1.4)
<b>Leakages on hydraulic or pneumatic circuits</b>	Wrong calibration of flow regulator valves	Restore (Sect. 3.6)
	Deterioration and/or damage to gaskets	Call BIFFI Italia S.r.l. Customer Service.
<b>Incorrect position of the valve</b>	Wrong adjustment of mechanical stops	Restore (Sect. 3.4)
	Wrong warning of microswitches	Restore (Sect. 3.5)
<b>Hydraulic manual pump does not work</b>	handle positioned on remote control	Position the handle on the indication of the operation to make
	Leakages on the check valve of the hydraulic control group	Call BIFFI Italia S.r.l. Customer Service

## 7 Layouts

### 7.1 SPARE PARTS ORDER

For spare parts order to the relevant BIFFI office please make reference to BIFFI order confirmation concerning all the supply, and serial number of the actuator (Sect. 1.2) for any specific spare part for a specific actuator model.

*Please send every spare-parts request to :*

*BIFFI ITALIA s.r.l. - Servizio Assistenza Tecnica Clienti*

*Tel. : 0523-944523\_\_\_\_\_*

*Fax: 0523-941885\_\_ e-mail: [spareservice@biffi.it](mailto:spareservice@biffi.it)*

*please specify :*

- 1. actuator model;*
- 2. BIFFI acknowledgement ;*
- 3. spare parts code;*
- 4. quantity;*
- 5. transport condition;*
- 6. involved people.*

## 7.2 PARTS-LIST FOR MAINTENANCE AND REPLACING PROCEDURE

Table 1 A : Double-chamber cylinder – pag.1 of 2

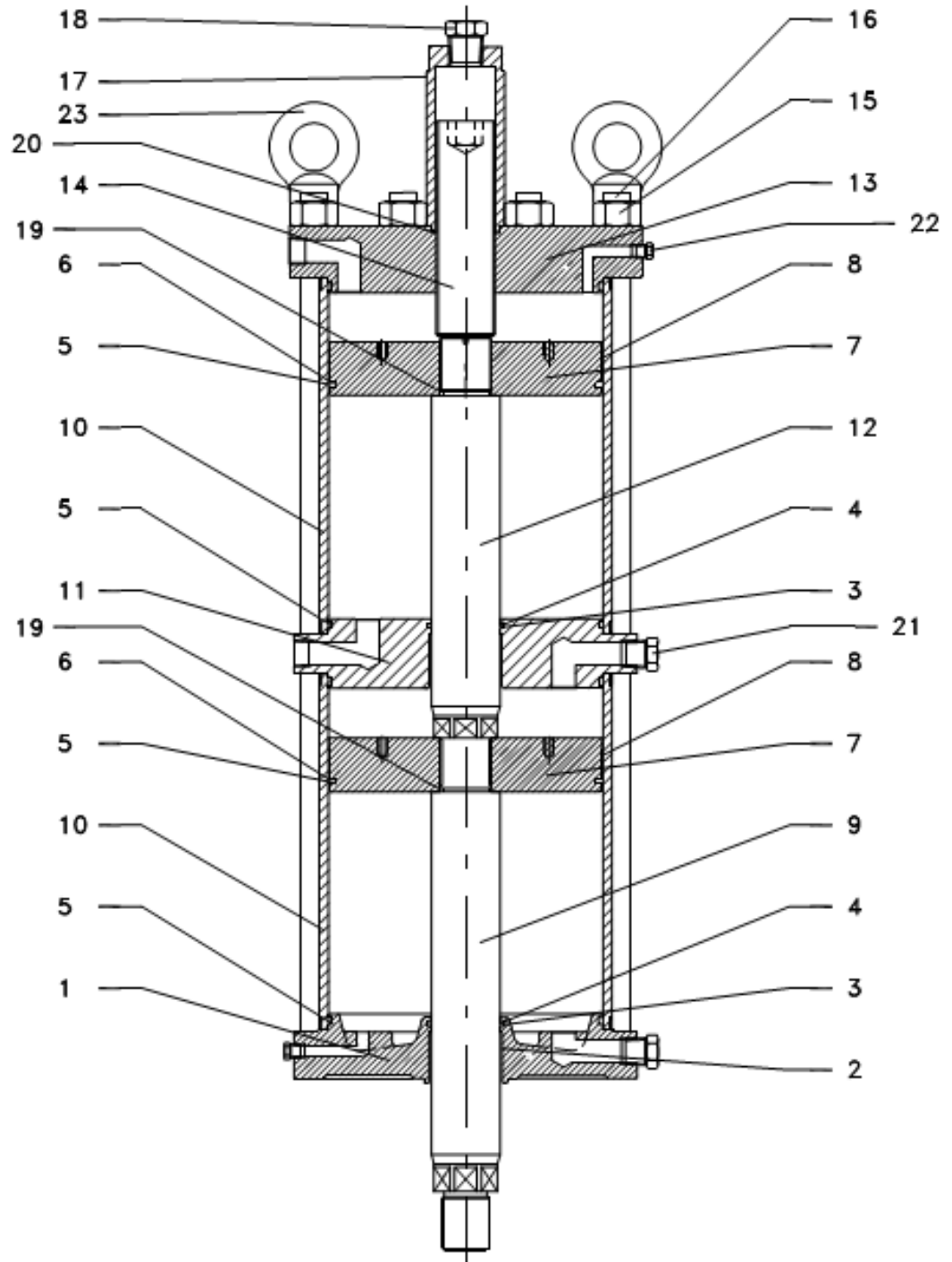

**Table 1 A : Double-chamber cylinder – pag. 2 of 2**

ITEM	Q.ty	DESCRIPTION	MATERIAL
1	1	Head flange	Carbon steel
2	2	Piston rod bushing	Steel + BZ + Teflon
3	2	O-ring	NBR Rubber
4	2	Piston rod seal ring	Teflon + graphite
5	4	O-ring	NBR Rubber
6	2	Piston seal ring	Teflon + graphite
7	2	Piston	Carbon steel
8	4	Guide sliding ring for piston	Teflon + graphite
9	1	Piston rod	Stainless steel ASTM A564-TP 630 chromium plated
10	2	Cylinder tube	Carbon steel
11	1	Intermediate flange	Carbon steel
12	1	Differential rod	Stainless steel ASTM A564-TP 630 chromium plated
13	1	End flange	Carbon steel
14	1	Stop setting screw	Stainless steel AISI 316
15	8	Nut	Stainless steel AISI 316LMO
16	8	Tie rod	Stainless steel ASTM A564-TP 630
17	1	Stop setting screw protection	Carbon steel
18	1	Plug	Carbon steel
19	2	O-ring	NBR Rubber
20	1	O-ring	NBR Rubber
21	1	Plug	Carbon steel
22	6	Plug	Carbon steel
23	2	Eyebolt	Carbon steel

**Table 2 B : Emergency manual hand-pump – pag . 1 of 3**

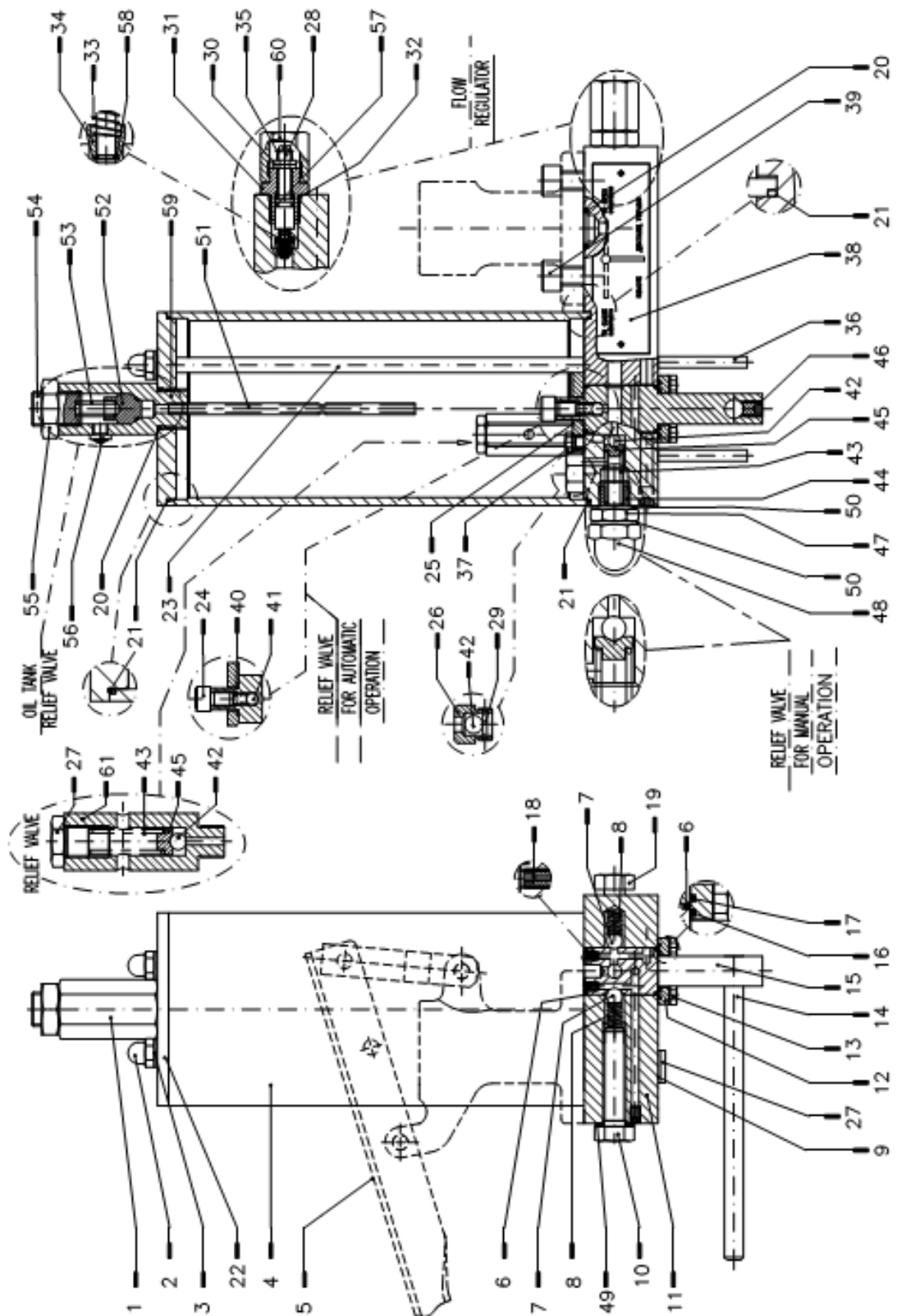

**Table 2 B : MHP - pag. 2 of 3**

ITEM	Q.ty	DESCRIPTION	MATERIAL
1	1	Dipstick	
2	2	Cap nut	Carbon steel
3	2	Washer	Carbon steel + rubber
4	1	Hydraulic tank	Carbon steel
5	1	Hand pump	See attached table
6	2	O-ring	Fluorosilicon rubber
7	2	Ball	Stainless steel
8	2	Spring	Spring steel
9	1	Washer	Carbon steel + rubber
10	1	Screw	Carbon steel
11	1	Plate	Carbon steel
12	1	Flange	Aluminium
13	4	Screw	Carbon steel
14	1	Lever	Carbon steel
15	1	Distributor	Stainless steel
16	1	O-ring	Fluorosilicon rubber
17	1	O-ring	Fluorosilicon rubber
18	1	Nozzle	Carbon steel
19	2	Screw	Carbon steel
20	3	O-ring	Fluorosilicon rubber
21	2	O-ring	Fluorosilicon rubber
22	1	Tank cover	Carbon steel
23	2	Tie rod	Carbon steel
24	1	Screw	Carbon steel
25	1	Flange	Aluminium
26	2	Check valve body	Aluminium
27	2	Plug	Carbon steel
28	2	Flow control valve setting screw	Stainless steel
29	2	Spring pin	Stainless steel
30	2	Nut	Carbon steel
31	2	Flange	Carbon steel
32	2	O-ring	Fluorosilicon rubber
33	2	Spring	Spring steel
34	2	Plug	Stainless steel
35	2	Retainer ring	Spring steel
36	2	Spring pin	Carbon steel
37	4	Screw	Carbon steel
38	1	Operation instruction plate	Stainless steel
39	4	Screw	Carbon steel
40	1	Spring	Stainless steel
41	1	Ball	Stainless steel
42	4	Ball	Stainless steel
43	2	Spring	Spring steel
44	1	Relief valve setting screw	Stainless steel
45	2	Spring pin	Carbon steel
46	1	Screw	Alloy steel
47	1	Spring	Stainless steel
48	1	Nut	Carbon steel
49	1	Washer	Carbon steel + rubber
50	2	Washer	Carbon steel + rubber
51	1	Dipstick	Stainless steel
52	1	Plug + o-ring	Stainless steel+fluorosil.rubber
53	1	Spring	Stainless steel
54	1	Screw	Alloy steel
55	1	Nut	Carbon steel
56	1	Silencer	Brass
57	2	O-ring	Fluorosilicon rubber
58	2	Retainer ring	Spring steel
59	1	Dipstick body	Aluminium
60	2	Nut	Carbon steel
61	1	Relief valve body	Aluminium

**Table 2 B : MHP - pag. 3 of 3**

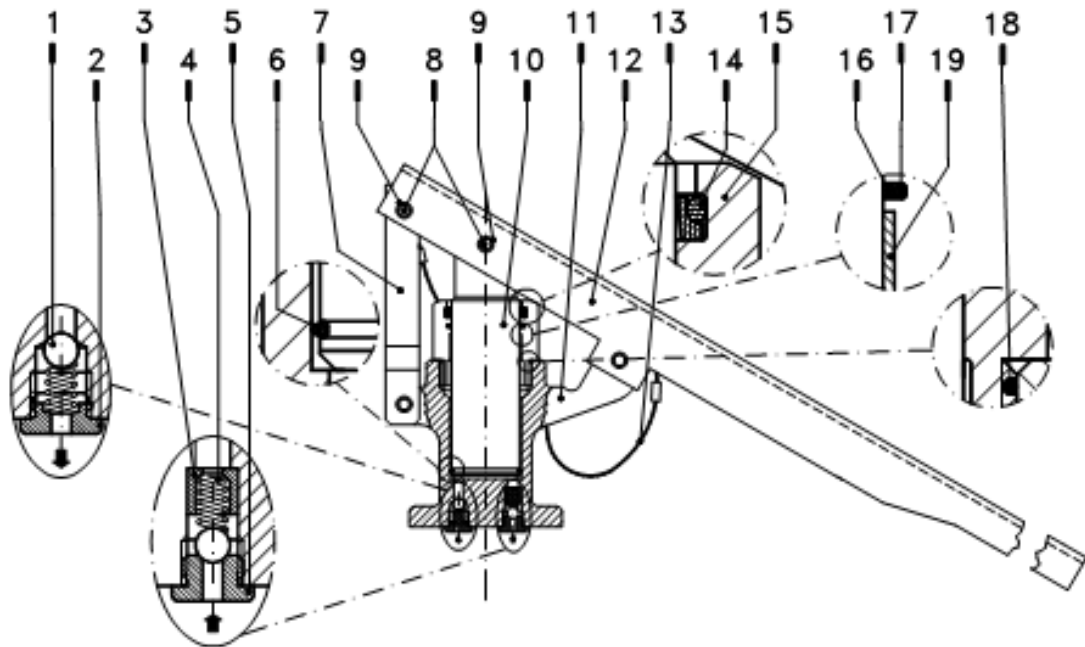

ITEM	Q.ty	DESCRIPTION	MATERIAL
1	2	Ball	Stainless steel
2	1	Delivery valve bush	Carbon steel
3	1	Suction valve bush	Carbon steel
4	2	Spring	Stainless steel
5	1	Suction valve seat	Carbon steel
6	1	Spring retainer ring	Carbon steel
7	1	Fork	Carbon steel
8	3	Pin	Stainless steel
9	6	Retainer ring	Carbon steel
10	1	Rod	Chromium plated alloy steel
11	1	Body	Carbon steel
12	1	Lever	Carbon steel
13	1	Split pin with rope	Nylon + Carbon steel
14	1	Scraper ring	Teflon+Fluorosilicon rubber
15	1	Threaded bush	Alluminium
16	2	Rod seal ring	Teflon + graphite
17	2	O-Ring	Fluorosilicon rubber
18	1	O-Ring	Fluorosilicon rubber
19	1	Piston rod bushing	Steel + BZ + Teflon

**Table 6: Jackscrew manual override MSJ**

**Table 3 C : Pedestal with coupling joint**

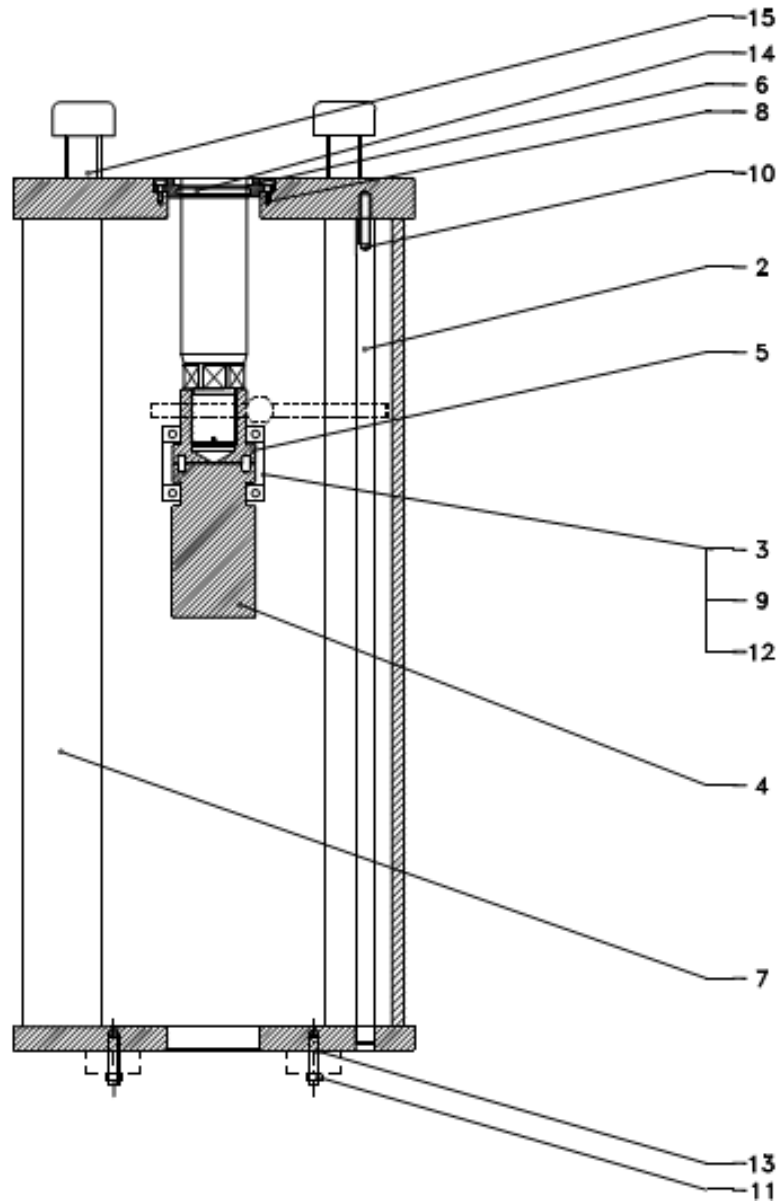

ITEM	Q.ty	DESCRIPTION	MATERIAL
2	1	Antirotating bar	Stainless steel
3	1	Shell joint	Alloy steel
4	1	Stem valve joint	Carbon steel
5	1	Actuator joint	Carbon steel
6	1	Scraper ring support	Stainless steel
7	1	Pedestal	Carbon steel
8	4	Screw	Stainless steel
9	4	Screw	Stainless steel
10	1	Screw	Stainless steel
11	8	Nut	Alloy steel
12	4	Nut	Stainless steel
13	8	Stud bolt	Alloy steel
14	1	Scraper ring	NBR rubber
15	4	Screw	Teflon

**Table 4 D : Mounting kit for limit switch-box**

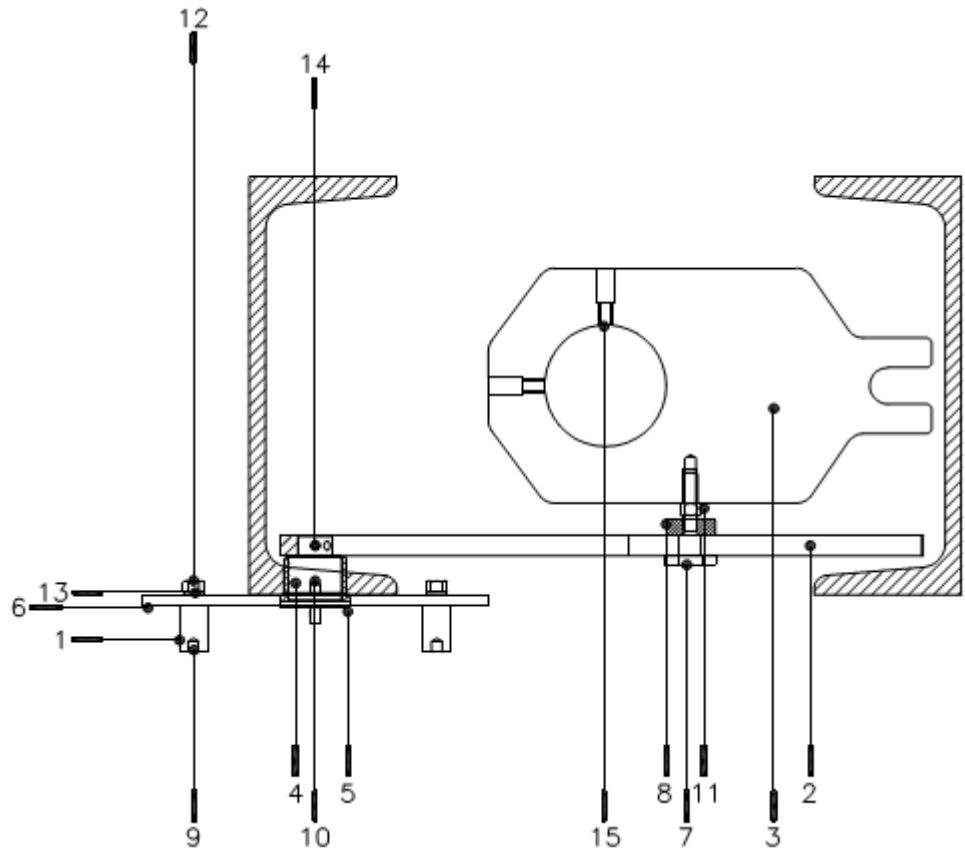

ITEM	Q.ty	DESCRIPTION	MATERIAL
1	4	Screw	Stainless steel
2	1	Spacer	Stainless steel
3	1	Driver ring	Stainless steel
4	1	Bush	Bronze
5	1	Support stud	Stainless steel
6	1	Support plate	Stainless steel
7	1	Threaded screw	Stainless steel
8	1	Washer	Stainless steel
9	4	Screw	Stainless steel
10	2	Screw	Stainless steel
11	1	Nut	Stainless steel
12	4	Nut	Stainless steel
13	4	Washer	Stainless steel
14	2	Screw	Stainless steel
15	2	Screw	Stainless steel

**Table 6 F : Pneumatic control group**

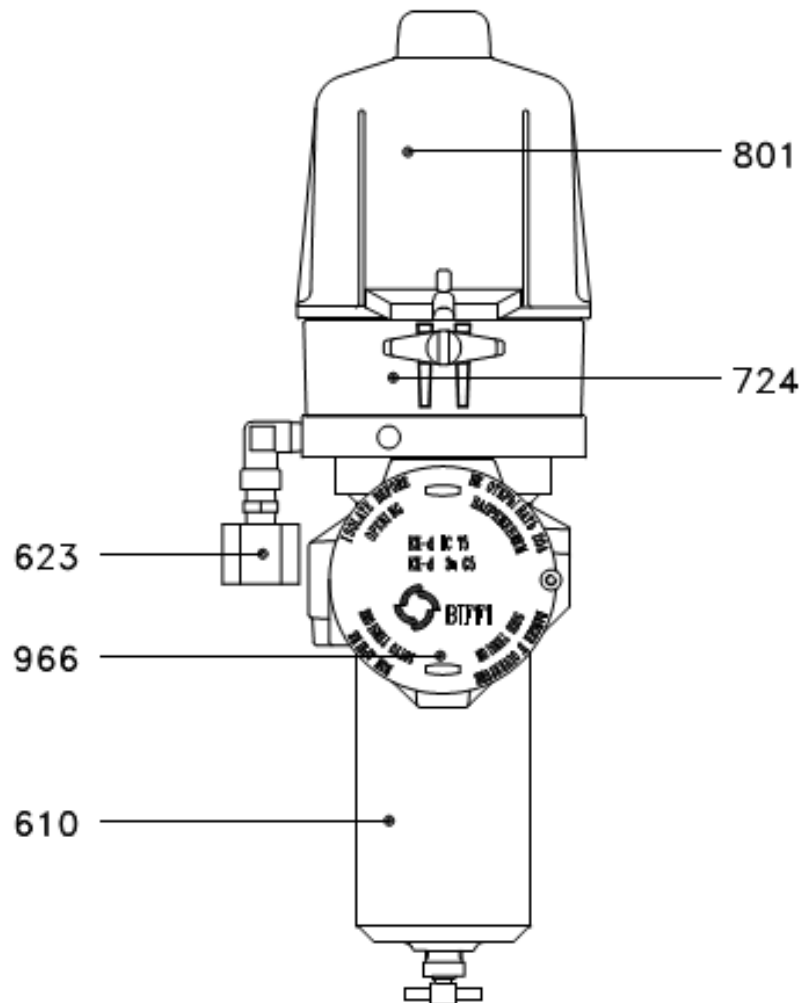

Item	Q.ty	DESCRIPTION
610	1	Gas dehydrating filler/condensate separator
623	1	Dust excluder with check valve
724	1	Double 3/2 N.C. solenoid valve with manual override
801	1	Control valves enclosure with vent valve
966	1	Terminals enclosure

**Table 7 G : Spring Cartridge**

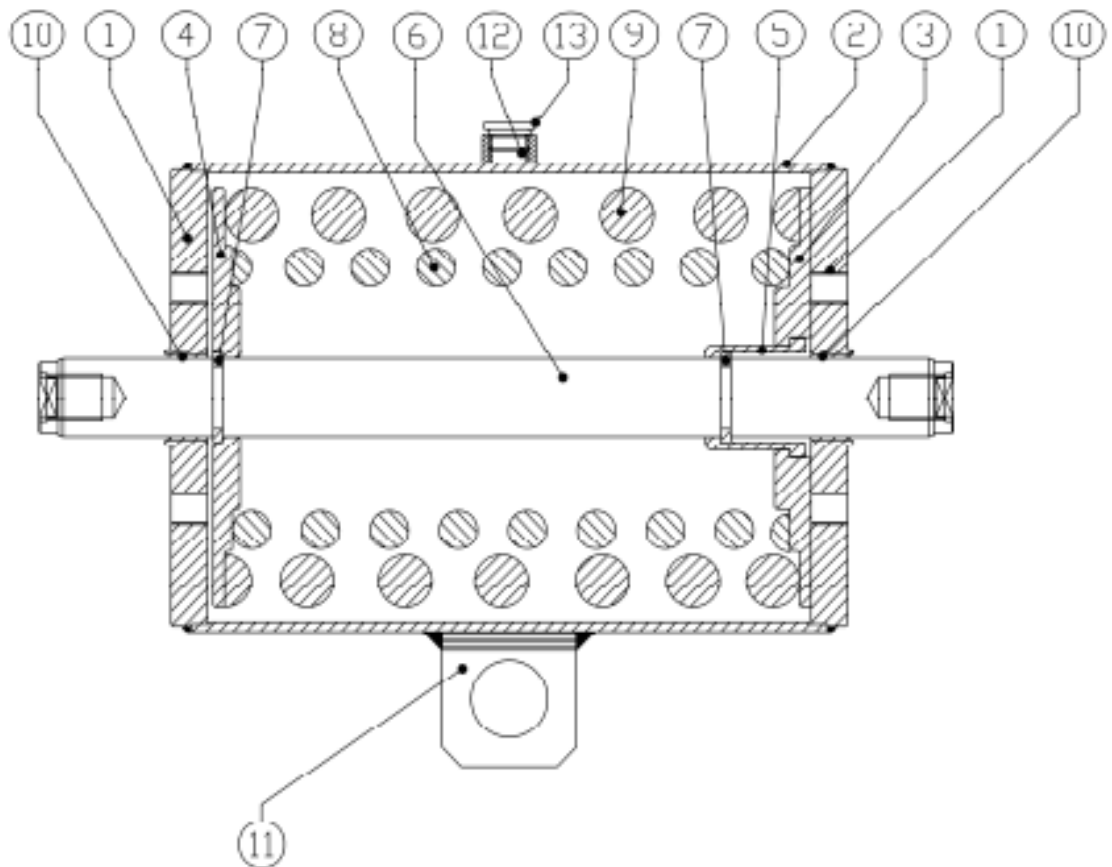

ITEM	Q.ty	DESCRIPTION	MATERIAL
1	2	Closing flange	Carbon steel
2	1	External tube	Carbon steel
3	1	Upper spring flange	Carbon steel
4	1	Lower spring flange	Carbon steel
5	1	Piston rod guide tube	Carbon steel
6	1	Stem	Stainless steel
7	4	Retainer half-ring	Stainless steel
8	1	Spring	Alloy steel
9	1	Spring	Alloy steel
10	2	Bush	Carbon Steel+Bronze+Teflon
11	1	Lifting eyelet	Carbon steel
12	1	Sleeve	Carbon steel
13	1	Plug	Alloy steel+NBR rubber

## **8 Date report for maintenance operations**

Last maintenance operation date : ( in factory, on delivery ) : .....

..... exec. by : .....

..... exec. by : .....

..... exec. by : .....

Next maintenance operation date: ..... exec. by : .....

..... exec. by : .....

..... exec. by : .....

Start-up date : ( in factory, on delivery ).....

( on plant ) .....