

Biffi OLGA-H

High Pressure Double-Acting Hydraulic Actuator

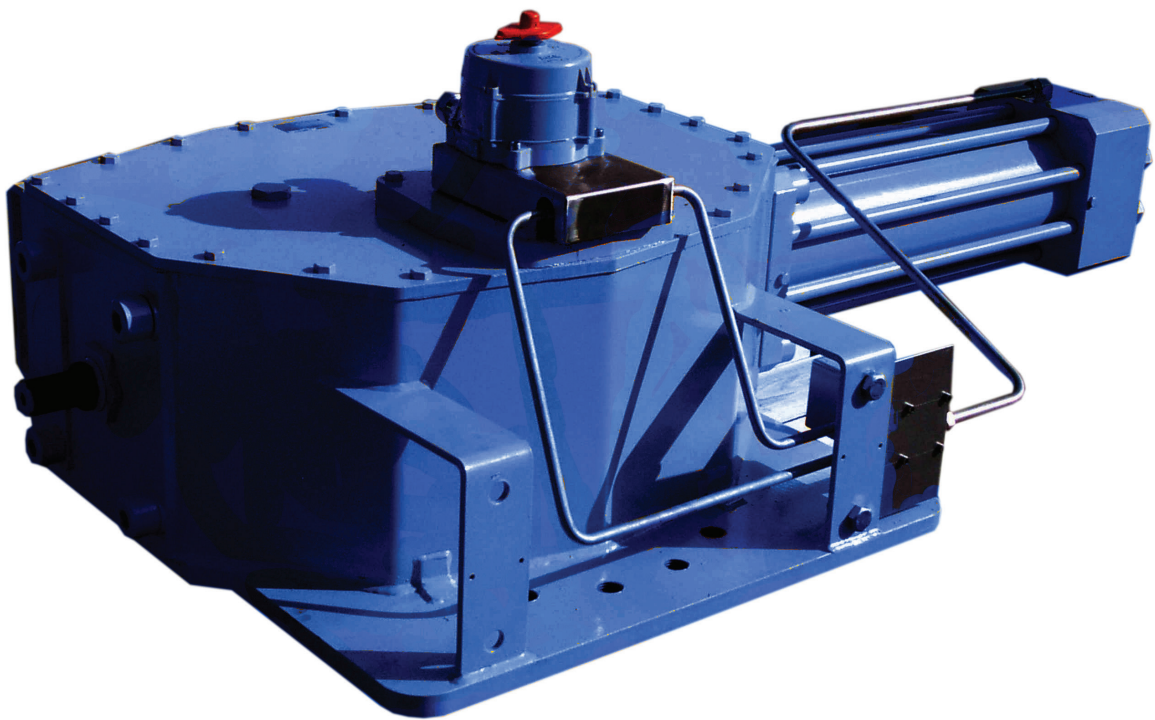

This page is intentionally left blank.

Table of Contents

Section 1: General Warnings

1.1	Generalities	1
1.1.1	Applicable Regulation	1
1.1.2	Terms and Conditions	1
1.2	Identification Plate	2
1.3	Introducing the Actuator	2
1.4	Data Sheet	3

Section 2: Installation

2.1	Checks Upon Actuator Receipt	4
2.2	Actuator Handling	4
2.3	Storage	8
2.4	Actuator Assembly on the Valve	8
2.4.1	Types of Assembly	8
2.4.2	Assembly Procedure	10
2.5	Hydraulic Connections	11
2.6	Electrical Connections (If Any)	12
2.7	Commissioning	13

Section 3: Operation and Use

3.1	Operation Description	14
3.2	Residual Risks	15
3.3	Operations	15
3.3.1	Local Manual Operation	15
3.3.2	Emergency Manual Operation by MHP	17
3.3.3	Emergency Manual Operation by MSJ - MHW	18
3.4	Calibration of the Angular Stroke	18
3.5	Calibration of Microswitches (Biffi Limit Switch Box Only)	23
3.6	Calibration of the Operation Time (Optional - if Foreseen)	25

Section 4: Operational Tests and Inspections

	Operational Tests and Inspections	27
--	---	----

Section 5: Maintenance

5.1	Periodic Maintenance	28
5.1.1	Check and Restore Oil Level in the Hydraulic Manual Override	30
5.2	Extraordinary Maintenance	32
5.2.1	Replacement of High Pressure Cylinder Seals	32
5.2.2	Replacement of Seals for Actuators With Biffi Manual Hand Pump	36
5.3	Lubrication of Mechanism	40
5.4	Dismantling and Demolition	41

Section 6: Troubleshooting

6.1 Failure or Breakdown Research..... 42

Section 7: Spare Parts

7.1 Spare Parts Order..... 43
7.2 Parts List for Maintenance and Replacing Procedure..... 44

Section 8: Date Report for Maintenance Operations

Date Report for Maintenance Operations 52

NOTICE

Biffi Italia s.r.l. pays the highest attention to collecting and verifying the documentation contained in this Installation, Operation and Maintenance (IOM) Manual. However, Biffi Italia s.r.l. is not liable for any mistakes contained in this manual and for damage or accidents due to the use of the latter. The information contained is of exclusive reserved ownership of Biffi Italia s.r.l. and may be modified without prior notice. All rights reserved.

Section 1: General Warnings

NOTICE

The manual is an integral part of the machine, it should be carefully read before carrying out any operation and it should be kept for future references.

1.1 Generalities

Biffi Italia s.r.l. actuators are conceived, manufactured and controlled according to the Quality Control System in compliance with EN-ISO 9001 international regulation.

1.1.1 Applicable Regulation

EN ISO 12100:2010: Safety of machinery – General principles for design – Risk assessment and risk reduction

2006/42/EC: Machine directive

2014/68/EU: Directive for pressure PED equipment

2014/35/EU: Directive for low voltage equipment

2014/30/EU: Directive for the electromagnetic compatibility

2014/34/EU: Directive and safety instructions for use in hazardous area

1.1.2 Terms and Conditions

Biffi Italia s.r.l. guarantees that all the items produced are free of defects in workmanship and manufacturing materials and meet relevant current specifications, provided they are installed, used and serviced according to the instructions contained in the present manual. The warranty can last either one year from the date of installation by the initial user of the product, or eighteen months from the date of shipment to the initial user, depending on which event occurs first. All detailed warranty conditions are specified in the documentation forwarded together with the product. This warranty does not cover special products or components not warranted by subcontractors, or materials that were used or installed improperly or were modified or repaired by unauthorized staff. In the event that a fault condition be caused by improper installation, maintenance or use, or by irregular working conditions, the repairs will be charged according to applicable fees.

The warranty and Biffi Italia s.r.l. liability shall lapse in the event that any modification or tampering whatsoever be performed on the actuator.



1.2 Identification Plate

⚠ WARNING

It is forbidden to modify the information and the marks without previous written authorization by Biffi Italia s.r.l.

The plate fastened on the actuator contains the following information (Figure1).

Figure 1. Data Plate

		Manufacturer: BIFFI ITALIA Strada Biffi, 165 29017 Fiorenzuola D'ARDA (PC) - ITALY			
Order _____					
Model _____					
ACTUATOR	S/N _____		MM/YYYY _____		
	TAG N° _____		ND _____		
Supply Press. Range _____				MOP _____	
Amb. Temp. _____					
CYLINDER	Fl. Type _____		Fl. Group _____		PED Cat. _____
	TS _____		Test Date _____		_____
	PS _____		PT _____		Cyl. Weight _____
		Ref: _____		WARNING: Potential Electrostatic Charging Hazard See Instructions	

1.3 Introducing the Actuator

The hydraulic actuator series OLGA-H was engineered and is manufactured to provide maximum torque output with minimum supply pressure. The OLGA-H actuators are suitable for any quarter turn application such as ball, plug, butterfly valves or dampers, in both On-Off and Modulating heavy-duty service.

The actuator (see Figure 2) is made up of a weatherproof scotch yoke mechanism transforming the linear movement of the pneumatic cylinder (on closing or opening) into the rotary movement, which is necessary for operation. The angular stroke of the yoke is adjustable between 82° and 98° by means of the external mechanical stops screwed into the left wall of the mechanism housing and into the end flange of the pneumatic cylinder. The cover of the scotch yoke mechanism is arranged for the assembly of the required accessories (positioner, signalling limit switches, position transducer, etc.) by means of proper matching units. The above mentioned accessories are operated by the actuator drive sleeve. The housing of the scotch yoke mechanism has a flange with threaded holes to fix the actuator to the valve either directly or, if required, with the interposition of an adaptor flange or a mounting bracket. The actuator yoke has a hole with keyways suitable for the assembly of an insert bush the internal hole of which is machined (by Biffi or at Customer's care), according to the shape and dimensions of the valve stem. Biffi can supply different types of control system following customer's requirements.

The expected lifetime of actuator is approximately 25 years.

Figure 2. Identification of Actuator Parts

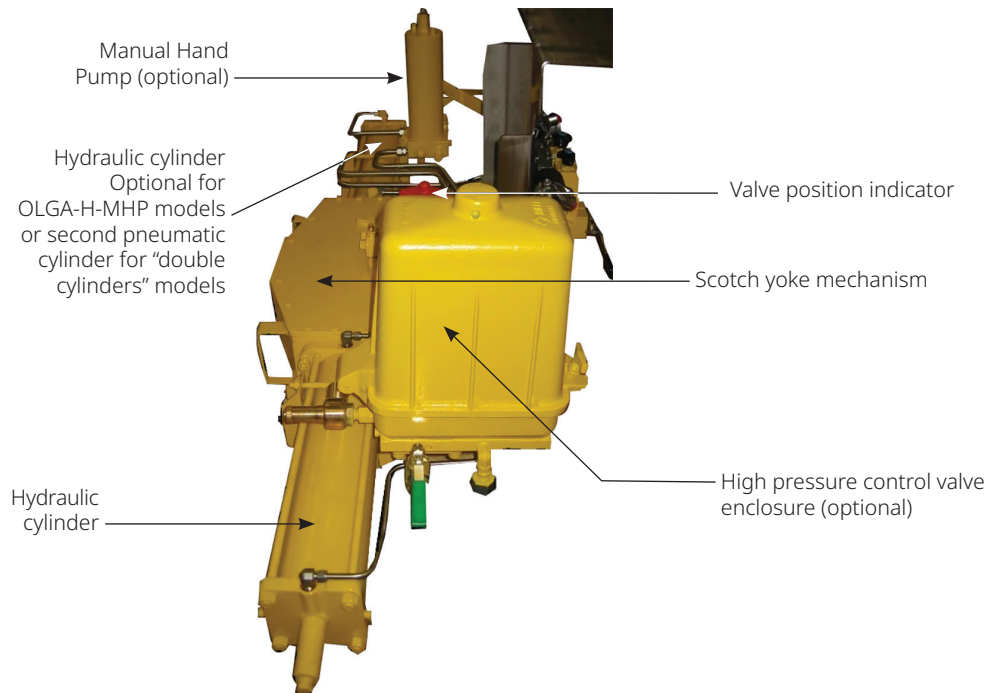

1.4 Data Sheet

Supply fluid	Hydraulic oil, special version for fire-resistant fluids
Operating temperature	Standard: from -30 to +100 °C Optional: from -60 to +140 °C
Supply pressure	Please refer to technical document: "actuator data sheet"

Section 2: Installation

2.1 Checks Upon Actuator Receipt

- Check that the model, the serial number of the actuator and the technical data reported on the identification plate correspond with those of order confirmation, refer to Section 1.2.
- Check if the actuator is equipped with the fittings as provided for by order confirmation.
- Check if the actuator was not damaged during transportation: if necessary, renovate the painting according to the specification reported on the order confirmation.
- If the actuator is received already assembled with the valve, its settings have already been made at the factory.
- If the actuator is delivered separately from the valve, it is necessary to check, and if required, to adjust the settings of the mechanical stops (Section 3.4), and of microswitches (if any) (Section 3.5).

2.2 Actuator Handling

NOTICE

The lifting and handling of the actuator must be done by qualified personnel and in accordance with the laws and regulations in force. Avoid hanging the lifted actuator above any personnel.

⚠ WARNING

The actuator must be lifted by means of a suitable lifting apparatus. The weight of the actuator is indicated in the technical documentation attached to the equipment itself.

⚠ WARNING

For lifting and moving the actuator, use only hooks fitted with safety latch, like the one, shown in Figure 3.

Figure 3. Example of Hook With Safety Latch



Figure 4. Lifting Points for OLGA-H/OLGA-H MHP/OLGA-H MSJ

1-2 = LIFTING POINTS (OBLIGATORY)
 3 = BALANCING POINT

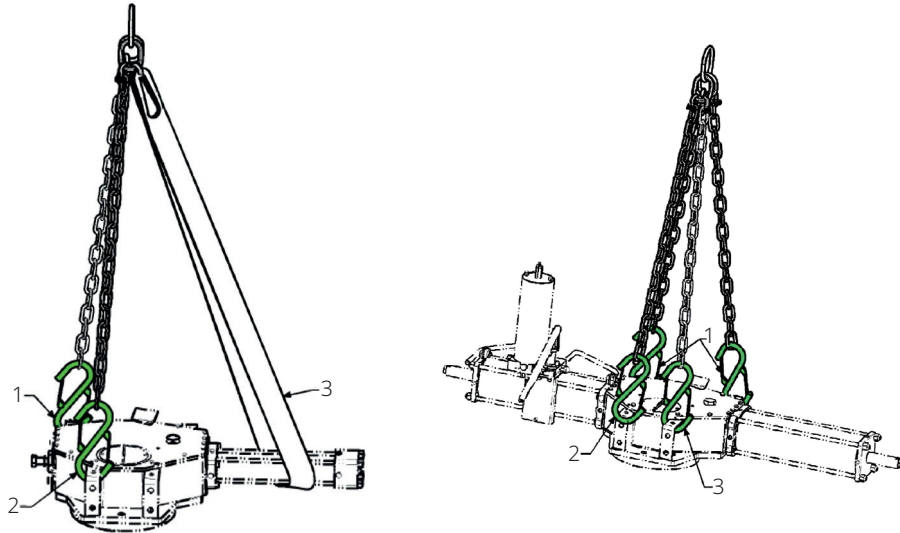
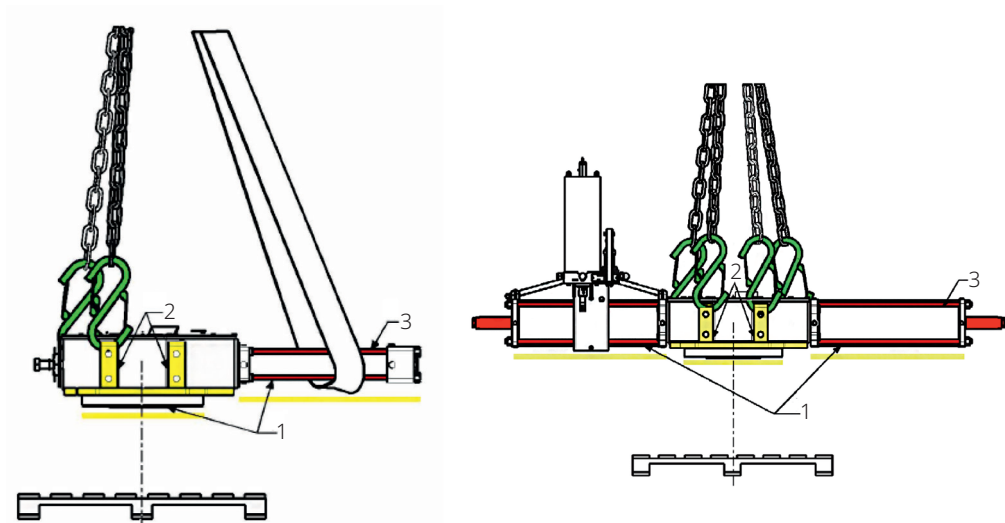

Figure 5.

1 = POINT OF SUPPORT
 2 = SUPPORTS FOR LATERAL POSITIONING



⚠ WARNING

3 = Do not lay the actuator on tie-rods of cylinder/s and do not lay the actuator on accessories (manual override, pneumatic control group, etc.).

- When lifting unbalanced loads, use ropes of different lengths or chains with adjustable length.
- Always check the condition of all lifting equipment used and discard it if not in perfect working order.
- Do not knot or twist the ropes so as not to reduce the lifting capacity or produce torsional effects on the load being lifted.
- Exercise utmost caution and remain at a safe distance from lifted actuator unless absolutely necessary; do not stand or pass under suspended loads.
- Pay attention in putting the ropes under tension to prevent the load shifting sideways in an uncontrolled manner.
- Use slings of such length that the angles of the leg from vertical are as narrow as possible ($\alpha_{MAX} < 20^\circ$).
- During handling, do not transport the suspended actuator above staff members in charge of the operation.

⚠ WARNING

Do not use the lifting eyelets on the actuator to lift valve + actuator assembly.

Figure 6.

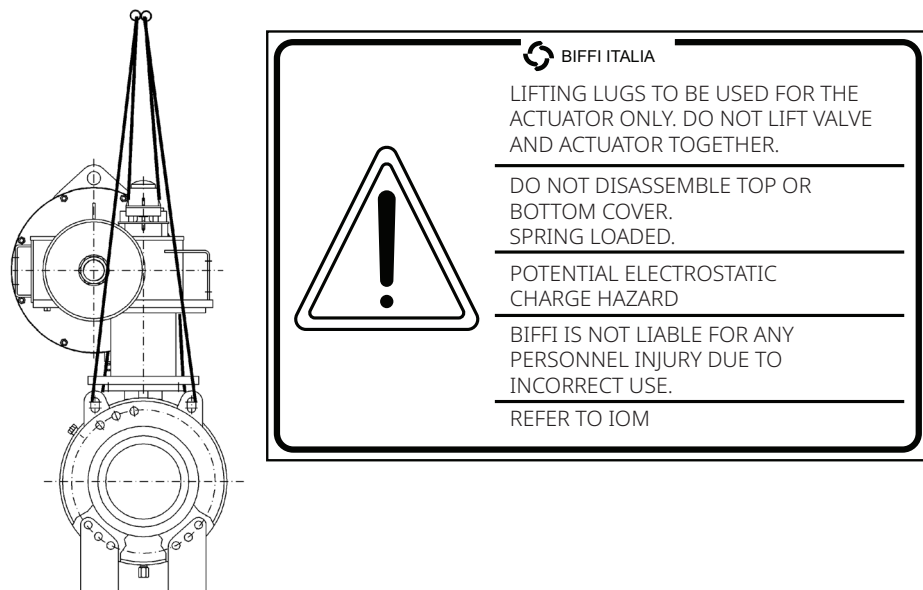
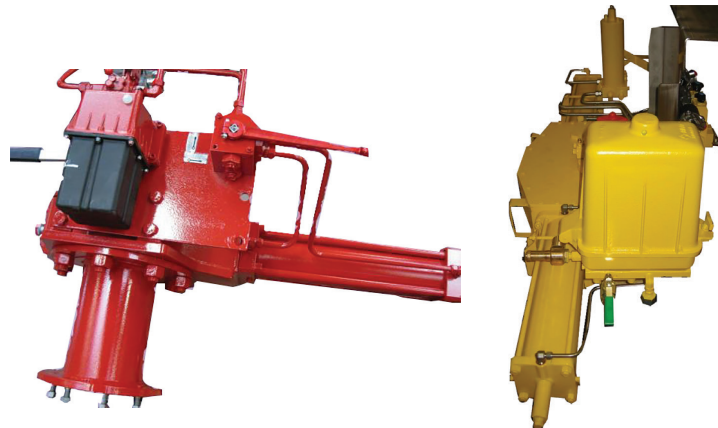

Figure 7.



Biffi hydraulic manual hand pump must be maintained with tank in upper position to operate the actuator with MHP correctly.

For transporting OLGA-H actuators with hydraulic manual hand pump, when it is necessary, put the tank of MHP in horizontal position to avoid leakage on oil level stick. Substitute this with a blind plug during the transport (a specific warning label for transport in horizontal position is attached on the MHP body), remove the blind plug and restore the dipstick before operating the actuator with MHP.

Figure 8.

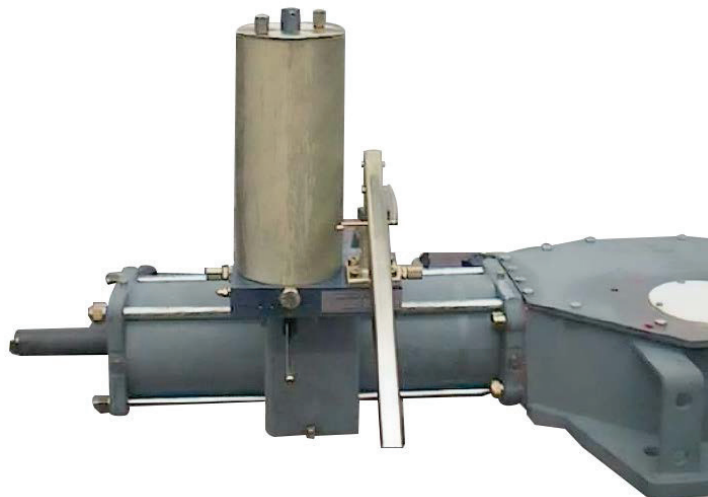

OMFB manual hand pump should be transported and used with MHP tank in horizontal position, but in position 3 of the following figure (extracted from OMFB technical documentation), it is necessary to change the position of suction pipe and breather cap.

Figure 9.

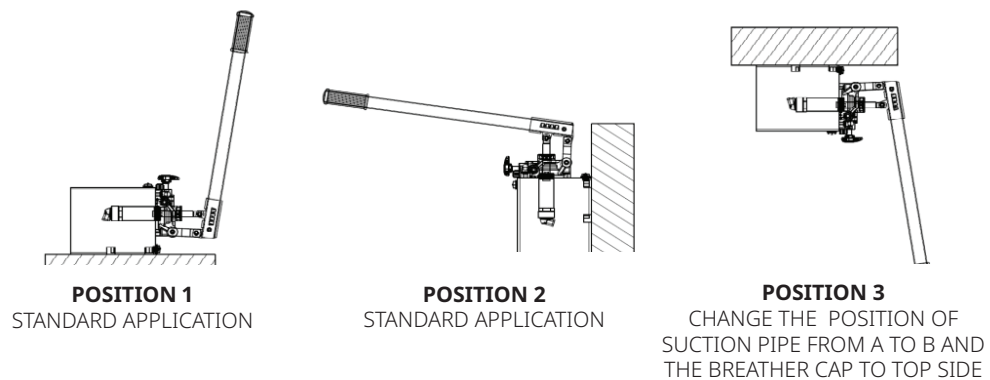

2.3 Storage

If the actuator needs to be stored before installation, follow these steps:

- Place it on a wood surface in order not to deteriorate the area of valve coupling.
- Make sure that plastic plugs are present on the hydraulic and electrical connections (if present).
- Check that the cover of the control group and of the limit switch box (if any) are properly closed.

If the storage is long-term or outdoor:

- Keep the actuator protected from direct weather conditions.
- Replace the plastic plugs of hydraulic and electrical connections (if any) with metal plugs that guarantee perfect tightness.
- Coat the valve coupling area with oil, grease or protection disc.
- Periodically operate the actuator (Section 3).

2.4 Actuator Assembly on the Valve

2.4.1 Types of Assembly

For coupling to the valve, the housing is provided with a flange with threaded holes according to Biffi standard tables (SCN6200; SCN6200-1; SCN6201; SCN6201-1). The number, dimensions and diameter of the holes are made in accordance with ISO 5211, but for actuator models 0.3 to 6 the holes are drilled on the centerline in order to allow an easier assembly of an intermediate flange, when required. This intermediate flange (or spool-piece) can be supplied when the valve flange cannot directly match the actuator flange in its "standard" configuration. For the biggest actuator models, the actuator flange can be machined in accordance with the valve flange dimensions. The yoke is bored with keyways for coupling to the valve stem, the dimensions of which are according to Biffi standard tables SCN6200* and SCN6201*. If required, for the standard models size 0.3 to 6, Biffi can supply an insert bush with unmachined bore in accordance with Biffi standard table SCN6202. On request, the insert bush bore can be machined by Biffi to couple the valve stem. The particular execution of the flange and bushing allow the actuator to be rotated by 90° in 4 different positions according to Figure 10.

Figure 10. Insert Bush + Intermediate Coupling Flange

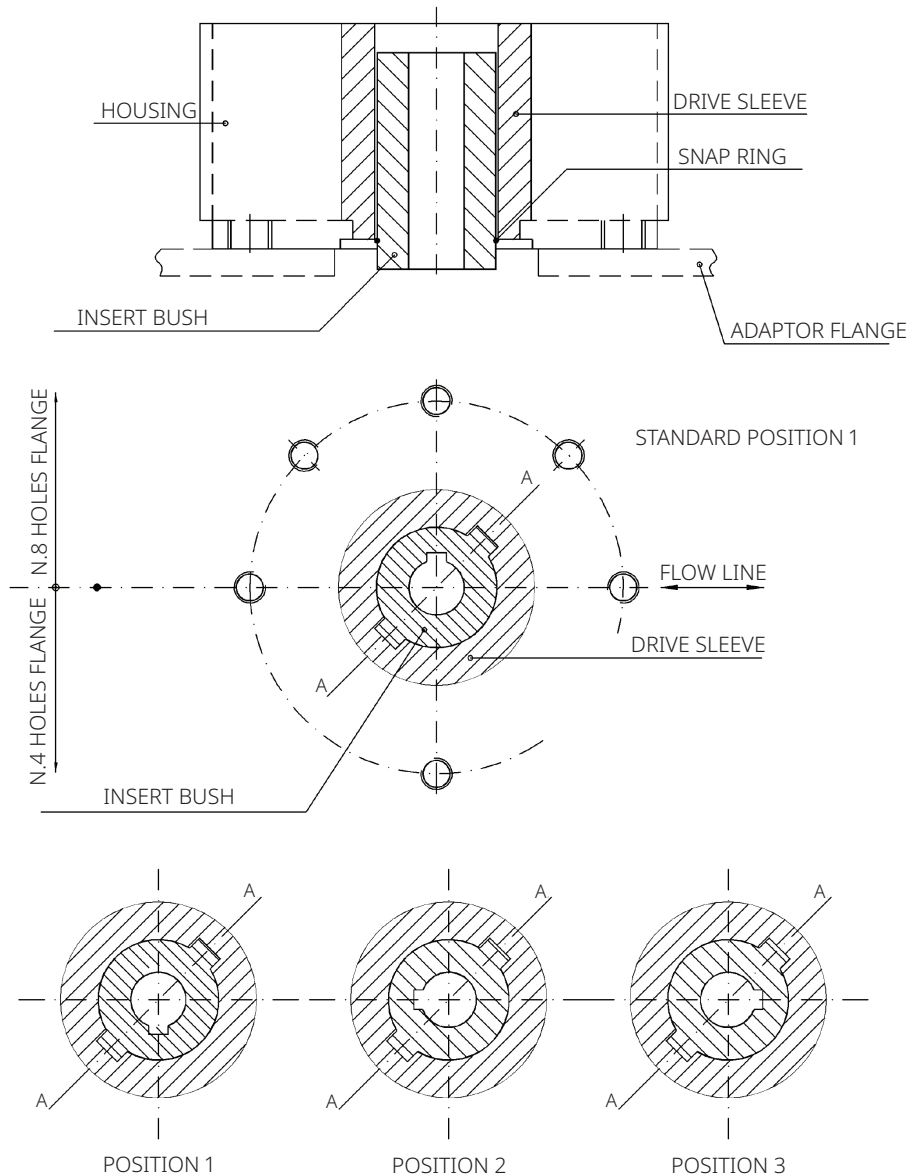

Table 1.

Position 2	Position 3	Position 4
Rotate insert-bush 180° around vertical-standard position 1	Rotate insert-bush 180° around axis A-A, from position 2	Rotate insert-bush 180° around axis A-A from position 1
Insert bush turned upside down		

The Biffi insert bush with 2 external keys at 45° allows to position the keyway for the valve every 90°. Consequently, actuator can be mounted in 4 positions at 90° on top of the valve. For biggest actuator models, the bore of the yoke can be machined according to the dimensions of valve stem.

2.4.2 Assembly Procedure

NOTICE

Failure to comply with the following procedures may impair product warranty.

⚠ WARNING

Installation, commissioning and maintenance and repair works should be carried out by qualified staff. A non-conforming assembly could be the source of serious accidents.

For actuator assembly on the valve:

NOTICE

Check that the assembly position, as shown on the documentation, complies with system's geometry. Check the consistency of the parts of actuator-valve coupling.

- Operate the actuator so that it reaches the position matching valve position (Section 3.3).
- Lubricate valve stem with oil or grease.
- Properly clean and remove grease from coupling flange surfaces.
- Connect, if supplied separately, the adjustment insert to valve stem and fasten it with the special fastening pins.
- Lift the actuator using the special lifting points (Section 2.2).
- Install the actuator so that valve stem inserts in the coupling area. This coupling should be made without forcing.
- Fasten the two parts with the threaded connections (screws, tie rods, nuts). If the holes of coupling flanges are not aligned, adequately operate the actuator. If necessary, move the mechanical stops backwards (Section 3.4).
- Fasten threaded connections. Please refer to Table 2.

Table 2. Nuts Tightening Torque

Threading	Tightening Torque (Nm)
M8	20
M10	40
M12	70
M14	110
M16	160
M20	320
M22	420
M24	550
M27	800
M30	1100
M33	1400
M36	1700

The screwing values in Table 2 were calculated considering the materials ASTM A320 Grade L7 for screws or tie rods and ASTM A194 Grade 2H for the nuts.

2.5 Hydraulic Connections

WARNING

Check if the values of hydraulic supply available in the system are compatible with those reported on the identification plate of the actuator.

NOTICE

The connections should be made by qualified staff. Use pipes, fittings and connections appropriate per type, material and dimensions.

Connect the actuator to the hydraulic feed line with fittings and pipes in accordance to the plant specifications. They must be sized correctly in order to guarantee the necessary oil flow for the operation of the actuator, with pressure drops not exceeding the maximum allowable value. The shape of the connecting piping must not cause excessive stress to the inlets of the actuator. The piping must be suitably fastened so as not to cause excessive stress or loosening of threaded connections, if the system undergoes strong vibrations. Every precaution must be taken to ensure that any solid or liquid contaminants, which may be present in the hydraulic pipework to the actuator, are removed to avoid possible damages to the unit or loss of performance. The inside of the pipes used for the connections must be well-cleaned before use; wash them with suitable substances and blow through them with oil or nitrogen. The ends of the tubes must be well-debarred and cleaned. Once the connections are completed, operate the actuator and check that it functions correctly, that the operation times meet the plant requirements and that there are no leakages in the hydraulic connections.

2.6 Electrical Connections (If Any)

⚠ WARNING

Use components appropriate as for type, material and dimensions. The connections should be made by qualified staff. Before carrying out any operation, cut line power off.

⚠ WARNING

Safety provisions:

- 2006/95/EC: Directive for low voltage equipment (until 19 April 2016)
2014/35/EU from 20 April 2016
- 2004/108/EC: Directive for the electromagnetic compatibility (until 19 April 2016)
2014/30/EU from 20 April 2016
- 94/9/CE: Directive and safety instructions for use in hazardous area
(until 19 April 2016) 2014/34/EU from 20 April 2016

Remove plastic plugs from cable entries.

- Screw firmly the cable glands.
- Introduce connection cables.
- Make the connections in compliance with applicable wiring diagrams on the documentation supplied.
- Screw the cable gland.
- Replace the plastic plugs of unused entries with metal plugs.

Figure 11. Junction Box on Control Group (if Foreseen)



2.7 Commissioning

WARNING

Check that values of electrical supply to the control group (if foreseen) are compatible with those on the plate on the junction box (Figure 11). Installation, commissioning and maintenance and repair works should be made by qualified staff.

Upon actuator commissioning, please carry out the following checks:

- Check that paint was not damaged during transport. If necessary, repair the damages to paint coat.
- Before start up and after every 6 months, check accumulator pre-charging pressure (please check the value in technical data sheet supplied).
- Check that the values of hydraulic supply available in the system are compatible with those reported on the identification plate of the actuator (Figure 1) and on the documentation supplied.
- Check that the feed voltage values of the electric components (solenoid valve coils, microswitches, pressure switches, etc.) are compatible with those reported on the identification plate of the actuator (Figure 1).
- Check that the setting of the components of the actuator control unit (pressure regulator, pressure switches, flow control valves, etc.), meet the plant requirements.
- Carry out all kinds of operations and check their proper execution (Section 3.3).
- Check the absence of leakages in the cylinder and in hydraulic connections. If necessary, tighten the nuts of the pipe-fittings.
- Check proper operation of all the due signalling (valve position, supply pressure, etc.).
- Make a complete functional test in order to verify that all the operations are executed according to operating schematic diagram supplied.

Section 3: Operation and Use

3.1 Operation Description

In the normal operating situation, the double-acting actuator is fed by pressurized oil which flows into the relevant cylinder chamber (for example opening). The cylinder piston stroke causes the actuator operation and the consequent valve movement to the operational position requested (in this case to the “open” position). Upon a demand, the closing chamber the cylinder is fed by pressurized oil and at the same time the oil is discharged from the open chamber into the return line: the actuator performs the closing operation driven by the piston movement, and the valve moves from the open position to the close (safety-related) position.

Figure 12.

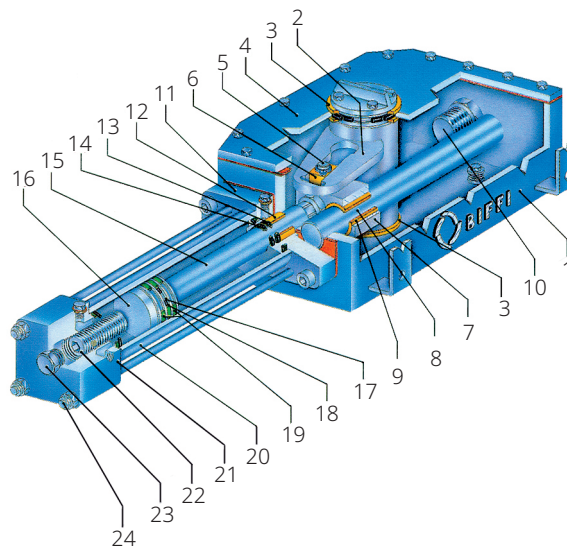

Table 3. Parts List

Item	Name	Item	Description
1	Housing	13	Piston rod O-ring
2	Yoke	14	Piston rod seal ring
3	Yoke bushing	15	Piston rod
4	Cover	16	Piston
5	Guide block pin	17	Piston O-ring
6	Sliding block	18	Piston seal ring
7	Guide block	19	Piston guide sliding ring
8	Guide bar	20	Cylinder tube
9	Guide block bushing	21	Cylinder end flange
10	Travel stop screw	22	Travel stop screw
11	Cylinder head flange	23	Plug
12	Piston rod bushing	24	Tie rod

For local or remote operations, please refer to Sections 3.3.1, 3.3.2, 3.3.3 and prior to technical documentation furnished with actuators. Typical schematics for various applications are attached for information only. The power and control systems are supplied on specific customer demand.

NOTICE

For all the relevant information please refer to the specific technical documentation supplied.

3.2 Residual Risks

⚠ WARNING

The actuator has parts under pressure. Exercise due caution. Use individual protections provided for by the laws and provisions in force.

3.3 Operations

Refer to specific document: operating diagram furnished.

3.3.1 Local Manual Operation

Figure 13. OLGA-H With Hydraulic Manual Hand Pump

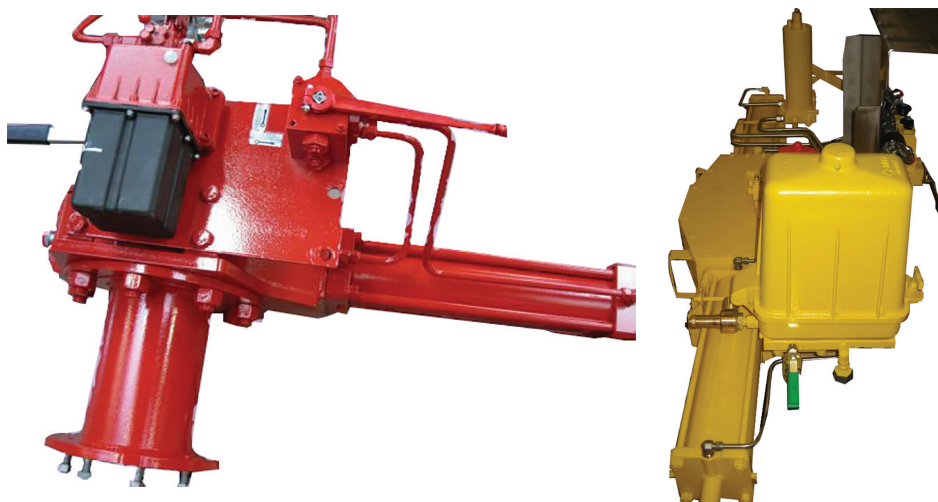
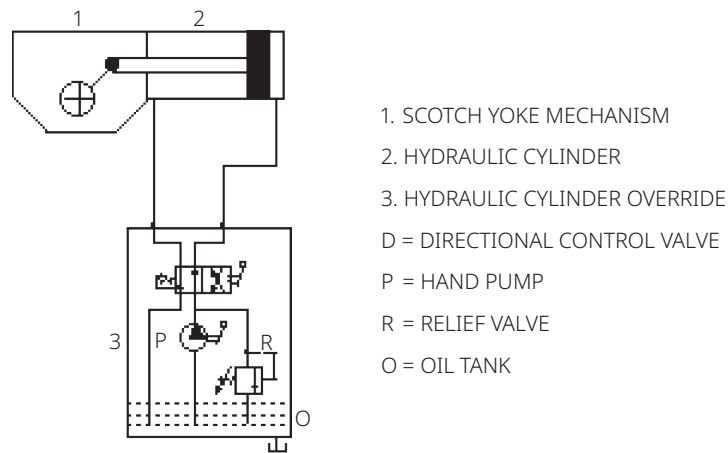

Figure 14.

The OLGA-H actuators can only have the hydraulic manual override for local operation. The compact hydraulic control unit mounted on the actuator consist of:

- Hand pump
- Directional control valve to select "to open" or "to close" actuator operation
- Relief valve to prevent the oil pressure delivered by the hand pump from exceeding the maximum allowable value
- Oil tank

Accessories are available on request, for instance:

- Dual pilot-operated check valve
- Bladder-type or piston-type accumulator delivered by the hand pump from exceeding the maximum allowable value. On request, the emergency manual override can be included in the power pack.

3.3.2 Emergency Manual Operation by MHP

Figure 15.

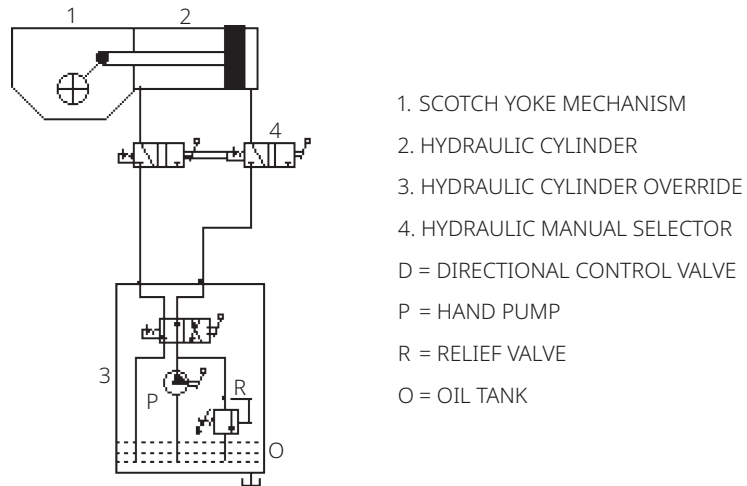

The OLGA-H actuators can have an emergency manual override in addition to the local and/or remote control panel which controls the oil supplied by a power pack for the “normal” actuator operation. The emergency manual override mounted on the actuator consists of a hydraulic manual override and a hydraulic manual selector to choose actuator “Normal operation” with oil supply from a power pack, or the “Emergency manual operation”. The compact hydraulic override consists of:

- Hand pump
- Directional control valve to select the “to open” or “to close” operation by hand pump
- Relief valve to prevent the oil pressure delivered by the hand pump from exceeding the maximum allowable value. On request, the emergency manual override can be included in the power pack.

3.3.3 Emergency Manual Operation by MSJ - MHW

Figure 16.

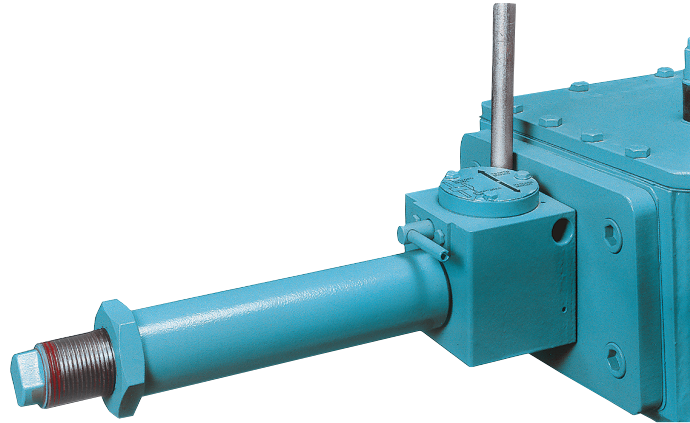

The MSJ jackscrew manual override can be supplied for OLGA actuators from models 0.3 to 3. The override is mounted on the left side of the actuator, the jackscrew end is screwed into the guide block. A bronze split screw nut is mounted inside the body. By rotating the engagement lever, the screw nut is engaged with the jackscrew. When the screw nut is engaged with the jackscrew manual operation, follow by rotating the body of the screw container by a lever. The manual jackscrew, on request, could be furnished with fixed handwheel welded on it.

3.4 Calibration of the Angular Stroke

The angular stroke of the yoke can be adjusted between $82^{\circ} \div 98^{\circ}$ ($\pm 4^{\circ}$ with respect to the nominal positions of complete opening and closing) by means of the mechanical stops screwed into the left side of the housing (open valve) and into the end flange of the hydraulic cylinder (closing) (Figure 17).

Figure 17. Mechanical Stops

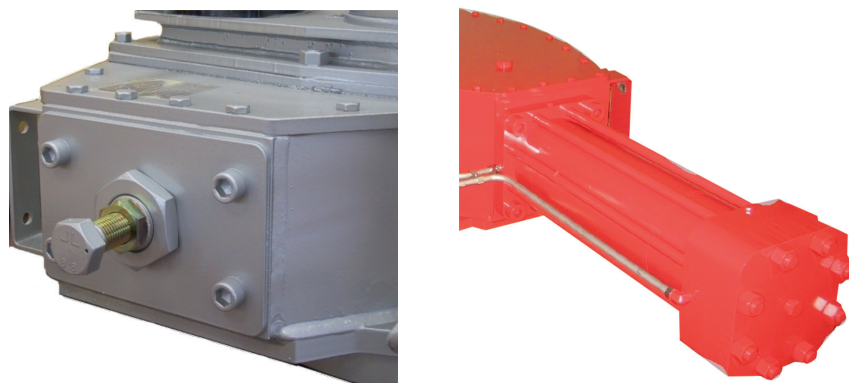

For the adjustment of the mechanical stop on the end flange of cylinder, follow these steps (Figure 18):

- Remove with the specific wrench (C2) the plug of cylinder end flange.
- Insert a wrench for Allen keys (C1) through the hole until reaching the adjustment pin.
- Turn counterclockwise to increase the angular stroke, turn clockwise to decrease it.
- When the adjustment is over, tighten the plug with the wrench (C2).

Figure 18. Mechanical Stop of the Cylinder

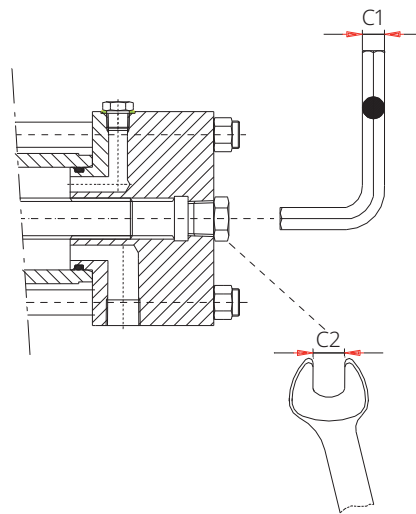

Table 4.

Hydraulic Cylinder Diameter	Wrench C1 (mm)	Wrench C2 (mm)
From 16 to 28	8	19
From 28 to 40	8	22
From 45 to 60	12	27
From 70 to 175	14	36
From 200 to 235	22	36
From 235 to 300	22	36

For the adjustment of the mechanical stop screwed into the left side of housing, follow these steps (Figures 19 and 20):

- Loosen the locknut (D) with the specific wrench (C2).
- Adjust the pin (G)/screw (V) with the adequate wrench (C1).
- Turn counterclockwise to increase the angular stroke, turn clockwise to decrease it.
- When the adjustment is over, tighten the locknut (D).

Figure 19. Mechanical Stop on Housing

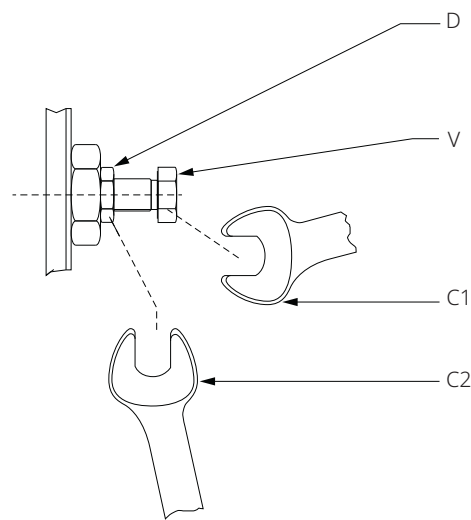

Table 5.

Actuator Model	Wrench C1 (mm)	Wrench C2 (mm)
0.1	30	30
0.3	30	30
0.9	30	30
1.5	41	41
3	41	41
6	46	46

Figure 20. Mechanical Stop on the Housing

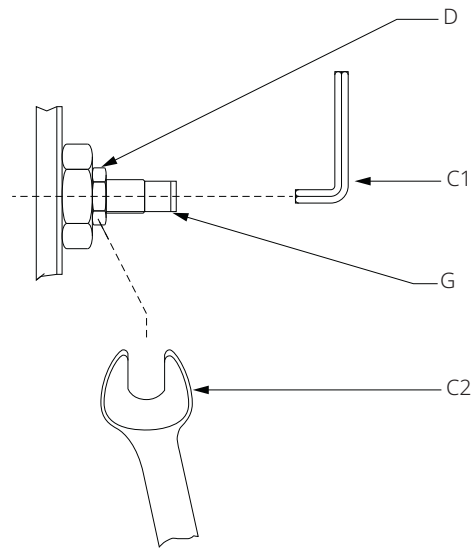

Table 6.

Actuator Model	Wrench C1 (mm)	Wrench C2 (mm)
14	17	60
18	17	60
32	17	60
50	17	60

For the adjustment of the mechanical stop screwed on the end flange of manual override, (see Section 7.2, Figure 38: sectional drawing for manual jackscrew MSJ).

Figure 21. Mechanical Stop on the End Flange of Manual Override

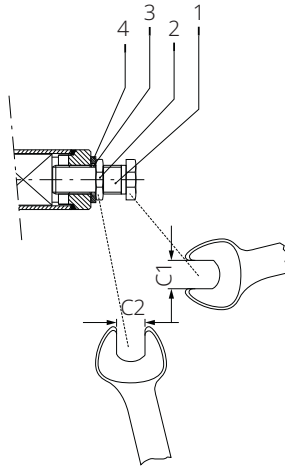

Table 7.

Actuator Size	Wrench C1 (mm)	Wrench C2 (mm)
0.1	34	34
0.3	34	34
0.9	34	34

Figure 22. Mechanical Stop on the End Flange of Manual Override

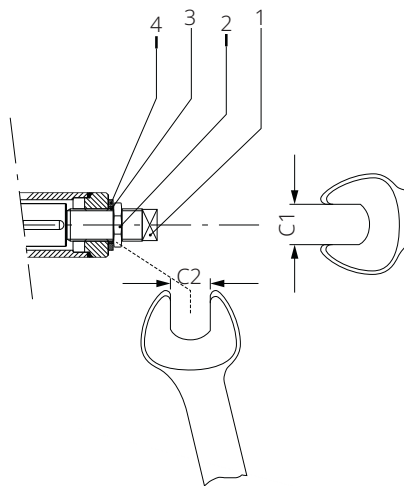

Table 8.

Actuator Size	Wrench C1 (mm)	Wrench C2 (mm)
1.5	24	65
3	24	65

3.5 Calibration of Microswitches (Biffi Limit Switch Box Only)

NOTICE

Operate only the microswitch corresponding to the direction of operation being carried out, as clearly reported on the microswitch.

⚠ WARNING

If different microswitches assembly or limit switch box is supplied, please refer to the specific documentation.

Microswitches are placed inside a special box (Figure 23).

For microswitches calibration, please refer to the relative wiring diagram and follow these steps:

- Unscrew the fastening screws of the cover (Figure 23).
- Remove the cover paying attention not to deteriorate the gasket and the cylindrical and flat coupling surfaces.
- Operate the actuator (in opening or closing).
- Unscrew the screw of the operating cam relative to the microswitch to calibrate and adjust it according to the settings (Figure 24).
- Tighten the screw.
- Operate the actuator and adjust any other microswitch with the procedure already described.
- Position the cover making sure the cam-carrier shaft grips with the index dragging shaft.
- Check that the cover and the index show the proper position of the valve (Figure 25).
- Tighten the screws.

Figure 23. Microswitches Box



Figure 24. Cam Adjustment

If the index (Figure 25) does not signal the proper position of the valve but is turned by 90°:

- Remove the roll pin placed on the position indicator (index).
- Turn the indicator until reaching its proper positioning.
- Put the roll pin back in its position.

NOTICE

End of stroke microswitches should be operated before the stop of the stroke of the actuator due to mechanical stops. Adjust the relative cams properly.

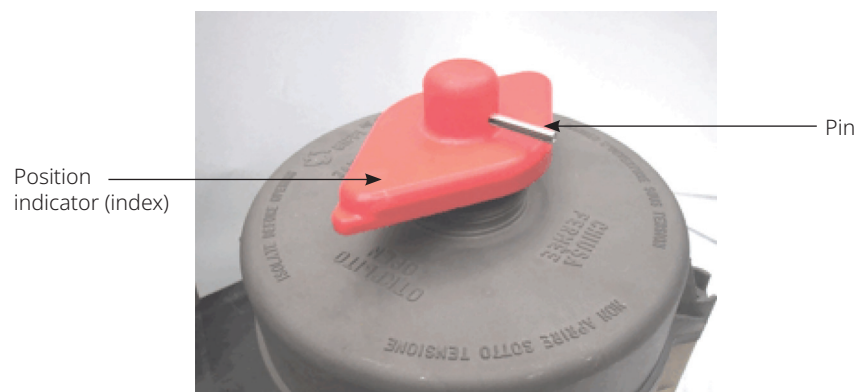
Figure 25. Position Indicator and Pin for Microswitches Box

3.6 Calibration of the Operation Time (Optional - if Foreseen)

The calibration of the operation time is made by Biffi Italia s.r.l. according to customer requirements and to technical data sheet included in technical documentation. If necessary, it is possible to modify or reset the operating time through two-flow regulation valves (optional) placed on inlets of hydraulic cylinder (see Figure 26 and the applicable operating diagram).

Figure 26. Example of Operating Time Adjustment by Flow-Regulator Valve

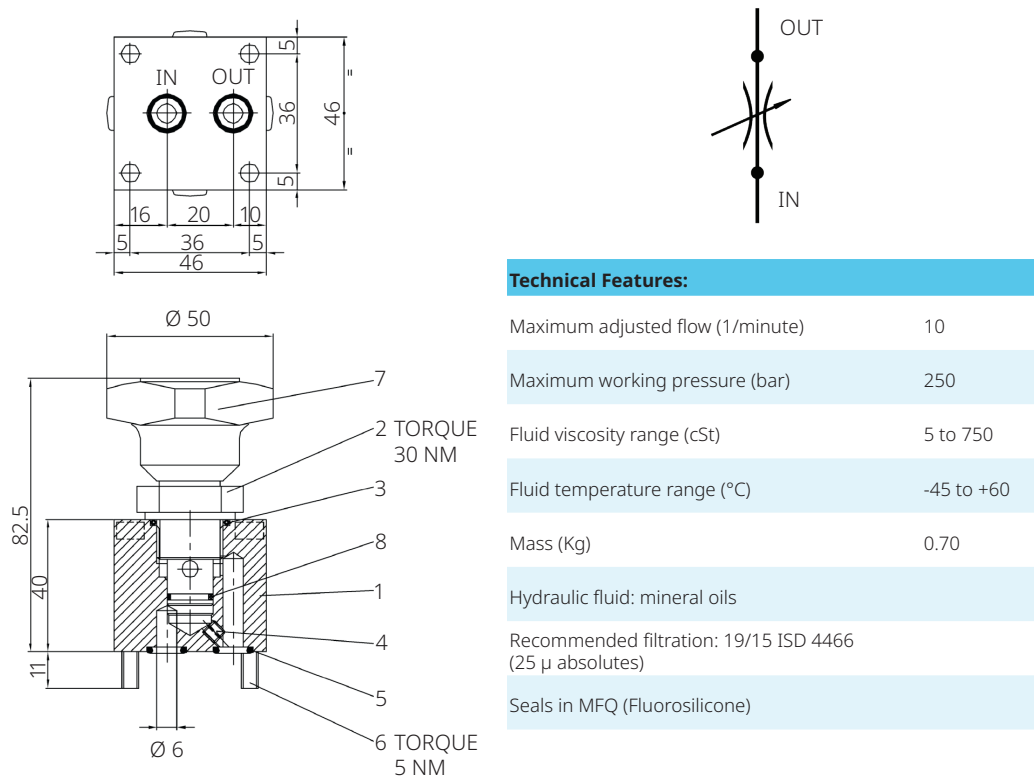

Table 9.

Position	Quantity	Denomination	Material	Type or Drawing
8	1	OB + 2BK (included in cartridge position 2)	MFQ-70Sh+PFTE	OR2-013 + 2BK
7	1	Handwheel	11S (2011)	29.102.378
6	4	Screw	A4-70	VTCEI M5x45 UNI 5931
5	2	O-ring	MFQ-70Sh	OR 5-612
4	1	Screw	A4-70	M5x45 UNI 5923
3	1	O-ring (included in cartridge position 2)	MFQ-70Sh	OR 2-116
2	1	Cartridge	A1SI 316	FT 2267/2-14-FQSV
1	1	Body	A1SI 316	49.144.031

To carry out the adjustment, operate the handwheel (turn the handwheel clockwise to increase the operating time or turn the handwheel counterclockwise to decrease the operation time).

For OLGA-H actuator with manual hand pump, the operating time is adjustable through two regulation valves placed on manual hand pump body (see Section 7.2, Figure 36: sectional drawing for Hydraulic Control Unit MHP).

To carry out the adjustment, use an adequate Allen wrench and follow these steps (Figure 27):

- Remove the cap nut.
- Loosen the locknut.
- Screw with a screwdriver the setting screw to increase the operation time.
- Unscrew with a screwdriver the setting screw to decrease the operation time.
- After the adjustment is over, screw the locknut and put back the cap nut in place.

Figure 27. Flow Regulators Placed on Manual Hand Pump

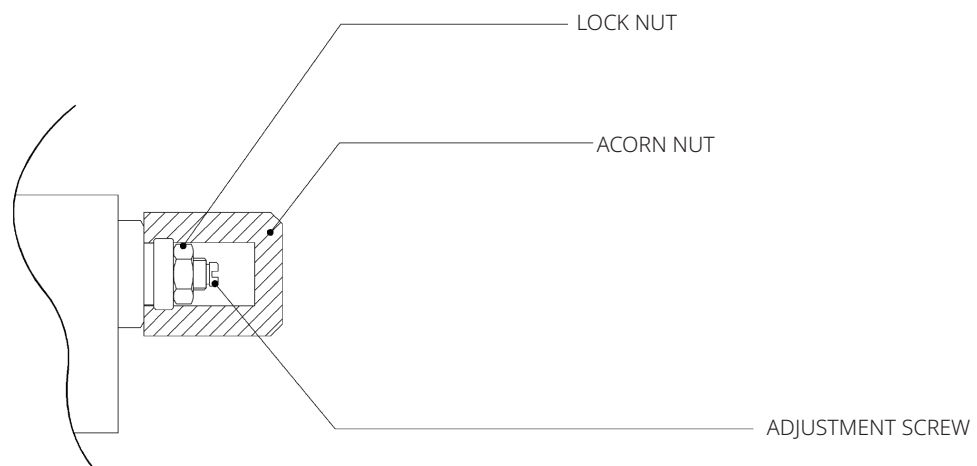

Section 4: Operational Tests and Inspections

NOTICE

To ensure the guaranteed SIL grade, according to IEC 61508, the functionality of actuator must be checked with regular intervals of time, as described in the Safety Manual.

Section 5: Maintenance

NOTICE

Before carrying out any maintenance operation, it is necessary to close the hydraulic feed line and exhaust the pressure from the actuator cylinder and from the control unit to ensure safety of maintenance staff.

⚠ WARNING

Installation, commissioning and maintenance and repair works should be carried out by qualified staff.

5.1 Periodic Maintenance

OLGA-H actuators are designed to operate long-term in heavy-duty operating conditions, without maintenance needs.

NOTICE

Periodicity and regularity of inspections is particularly influenced by specific environmental and working conditions.

NOTICE

They can be initially determined experimentally and then be improved according to actual maintenance conditions and needs.

⚠ WARNING

Before start-up and after every 6 months, check accumulator pre-charging pressure (if present: please check the value from technical data sheet supplied).

Every 2 years of operation, the following is recommended:

- Check that the actuator operates the valve correctly and with the required operating times. If the actuator operation is very infrequent, carry out a few opening and closing operations with all the existing controls (remote control, local control, emergency controls, etc.), if this is allowed by the conditions of the plant.
- Check if there are no hydraulic leakages. If necessary, tighten the nuts of the pipe-fittings.
- Check oil level (Figure 28) into the hydraulic control unit (see Section 5.1.1).
- Check if the actuators did not undergo accidental damage with oil leakages found on site.
- Check that improper closing of control group cover (if present) did not produce the presence of condensation on it.
- Check the integrity of worn-out parts (gaskets, pads, etc.).
- If there is an oil filter on the actuator, bleed the condensed water accumulated in the cup by opening the drain cock. Disassemble the cup periodically and wash it with soap and water; disassemble the filter; if this is made up of a sintered cartridge, wash it with nitrate solvent and blow through with oil. If the filter is made of cellulose, it must be replaced when clogged.

Figure 28. Level Measuring Stick



5.1.1 Check and Restore Oil Level in the Hydraulic Manual Override

Refer to Section 7.2, Figure 38.

Operate the distributor lever to “closing manual operation”.

Figure 29.

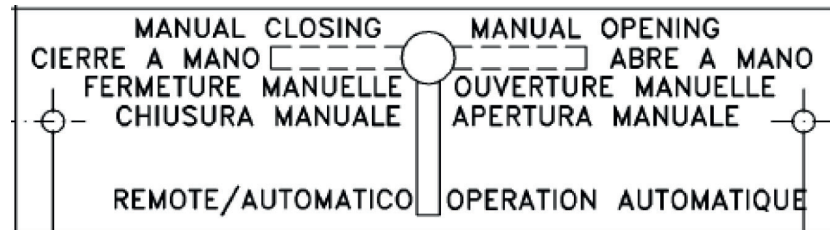

Move the actuator into its “fail to close” position.

Unscrew the dipstick (1).

Check that the oil level into the tank (4) is in correspondence of the “MAXIMUM LEVEL” notch of the dipstick.

Screw and tighten the dipstick.

If necessary, substitute or add the oil, proceeding as follows:

- Remove the dipstick (1) from the tank cover (22).
- Unscrew the plug (27) and the washer (9) to drain all the oil.
- If some dirt or/and sludge is found in the oil drained from the tank, before filling with new oil in the tank, disassemble the oil tank tube by unscrewing the two cap nuts (2), and clean the internal surfaces of the tank. If necessary, substitute the gaskets (21) of the tank.
- Replace the plug (27) and the washer (9) into the plate (11) and tighten.
- Pour the new oil into the tank through the dipstick hole (1) on the cover (22).
- Replace the dipstick (1).
- Add oil (refer to Table 10) if in the tank the oil level is BELOW THE MINIMUM (Figure 28: minimum level is in correspondence to the end of dipstick) until reaching the optimal (MAXIMUM) oil level.
- Operate the distributor lever to “Remote” position.

Table 10. Hydraulic Oil List by Biffi Italia s.r.l. for Refilling in Different Working Conditions

Standard Temperature Conditions (-30 to +85 °C):	
Producer	ENI®
Name	Arnica 22
Viscosity at 40 °C	20.9 mm ² /s
Viscosity at 100 °C	4.73 mm ² /s
Viscosity index ASTM	153
Flash point	192 °C
Pour point	-42 °C
Specific weight (at 15 °C)	0.857 kg/l
Equivalent oils:	Use an equivalent or better product in compliance with the oil proposed in the actual scope of supply by Biffi Fiorenzuola. Your oil supplier can verify and propose an alternative product at your responsibility.
Low Temperature Conditions (until -46 °C):	
Manufactured	Shell®
Name	AeroShell Fluid 41
Viscosity at -54 °C	2300 cST
Viscosity at -40 °C	491 cST
Viscosity at 40 °C	14.1 cST
Viscosity at 100 °C	5.30 cST
Viscosity index (ISO 2909)	>200
Flash point	105 °C
Pour point	<-60 °C
Specific weight (or equivalent)	0.87 kg/dm ³
Low Temperature Conditions (until -60 °C):	
Manufactured	* SYNTESIS
Name	* SYNTRASS-CS 500
Viscosity at -60 °C	580 cST
Viscosity at -30 °C	39 cST
Viscosity at 20 °C	5.8 cST
Viscosity at 50 °C	2.1 cST
Flash point	152 °C
Pour point	-68 °C
Specific weight (or equivalent)	0.897 kg/dm ³

NOTE:

* Refer to Fiorenzuola plant to receive a quotation for this oil.

NOTICE

For refill, use oil of the same brand as previous, refer to related technical documentation.

5.2 Extraordinary Maintenance

If there are leaks in the hydraulic cylinder, or a malfunction in the mechanical components, or in case of scheduled preventive maintenance, the actuator must be disassembled and seals must be replaced with reference to the following general sectional drawing and adopting the following procedures.

5.2.1 Replacement of High Pressure Cylinder Seals

Refer to the following parts list drawing.

NOTICE

Before executing any maintenance operation, it is necessary to intercept the supply line and discharge pressure from the cylinder of the actuator.

5.2.1.1 Replacement of Cylinder Seals

1. Unscrew the plug (27) from the cylinder end flange.
2. Measure the distance of the stop screw (23) with reference to the end flange (26) surface, so as to be able to easily restore the setting of the actuator mechanical stop once the maintenance procedures have been completed.
3. Unscrew the stop screw (23) by turning it counterclockwise with an Allen wrench until the screw is completely withdrawn inside the end flange threaded hole.
4. Unscrew the nuts (28) from the tie rods (19); they must be gradually unscrewed all at the same time.
5. Slide off the end flange (26) and the tube (22).
6. If the actuator control unit requires the cylinder chamber head flange side to be also filled with oil, and the piston rod seal ring (44) to be replaced, remove the screw (2) and the cover (1). Unscrew the piston rod (18) threaded end from the adaptor bush (32) of the guide block (14). Slide off the piston rod (18) from the head flange (33).
7. Disassemble the head flange (33) from the mechanism housing (8) by removing the screw (17) only if the gasket (39) and (41) have to be replaced because of damage.

5.2.1.2 Seals Replacement

Prior to reassemble, check if the actuator components are in good condition and are clean. Lubricate all the surfaces of the parts, which move in contact with other components, by recommended oil (ARNICA 22 or the oil used in the hydraulic cylinder). If the O-ring must be replaced, remove the existing one from its groove, clean the groove carefully and lubricate it with protective oil film. Assemble the new O-ring into its groove and lubricate it with a protective oil film.

1. Replace the O-ring (43) of the head flange (33).
2. Replace the O-ring (42) of the end flange (26).

To replace the piston rod seal rings (44), proceed as follows:

1. Remove the existing Polytetrafluoroethylene (PTFE) seal ring (44) with its O-ring from their groove.
2. Clean the groove carefully and lubricate it with a protective oil film.
3. Assemble the new O-ring into its groove and lubricate it with a protective oil film.
4. Assemble the new PTFE seal ring (44) into the flange groove, inside its rubber O-ring, by bending it; take care that the bending radius is as large as possible to avoid damaging the seal. Then, enlarge the seal ring with your fingers so as to restore its round shape; pay attention not to utilize any tools which can damage the seal ring.

To replace the piston seal ring (46), proceed as follows:

1. Remove the existing PTFE seal ring (46) with its O-ring from their groove.
2. Clean the groove carefully and lubricate it with a protective oil film.
3. Assemble the new O-ring into its groove and lubricate it with a protective oil film.
4. Assemble the new PTFE seal ring (46) on its rubber O-ring by introducing one side of it into the groove, then enlarge it with your fingers so as to fit it into the groove: take care to enlarge it uniformly without using any tools which could possibly damage it. The elastic memory of the kind of PTFE the seal ring is made of allows the ring to shrink back to its previous dimension after a short time.

5.2.1.3 Reassemble

1. Assemble the new gasket (39-41) after cleaning the surfaces of housing (8), the flange (40) and head flange (33) which are in contact.
2. Assemble the head flange (33), replace the washers if damaged, tighten the screw (17) to the recommended torque.
3. Lubricate the piston rod (18) surface, with a protective oil or grease film and introduce it into the head flange hole, taking care not to damage the O-ring (43). Carefully clean the threaded end of the piston rod (18) and the threaded hole of the adaptor bush (32) of guide block (14). Spread some sealant LOCTITE® 452, or equivalent, on the rod threaded end and tighten.
4. Carefully clean the inside of the tube (22) and check that the entire surface, particularly that of the bevels, is not damaged. Lubricate with a protective oil film the tube internal surface and the bevels at the ends. Slide the tube onto the piston taking care not to damage the PTFE seal ring (46): the tube bevel has to smoothly compress the seal ring; take care also not to damage the head flange O-ring (43).
5. Assemble the end flange by centring it on the inside diameter of the tube, taking care not to damage the O-ring (43).
6. Assemble the nuts (28) onto the tie rod (19). Tighten the nuts to the recommended torque, alternating between opposite corners.
7. Restore a generous coating of grease on the contact surfaces of the yoke (11) and the bushing (35), on the yoke grooves, on the sliding block (5), on guide bar (9).
8. Assemble the new gasket (10) after cleaning the surfaces of the housing (8) and cover (1).
9. Lubricate with protective oil or grease the O-ring (34).
10. Assemble the cover (1) and the screw (2). Tighten the screws to the recommended torque.
11. Screw the stop screw (21) by turning it clockwise with an Allen wrench until it reaches its original position (the same distance with reference to the end flange surface).
12. Screw the plug (27) into the cylinder end flange.

NOTICE

After maintenance operations, carry out a few actuator operations to check that its movement is regular and that there is no oil leakage through the seals.

Figure 30. OLGA-H/MHP Double-Acting Actuator With Manual Override

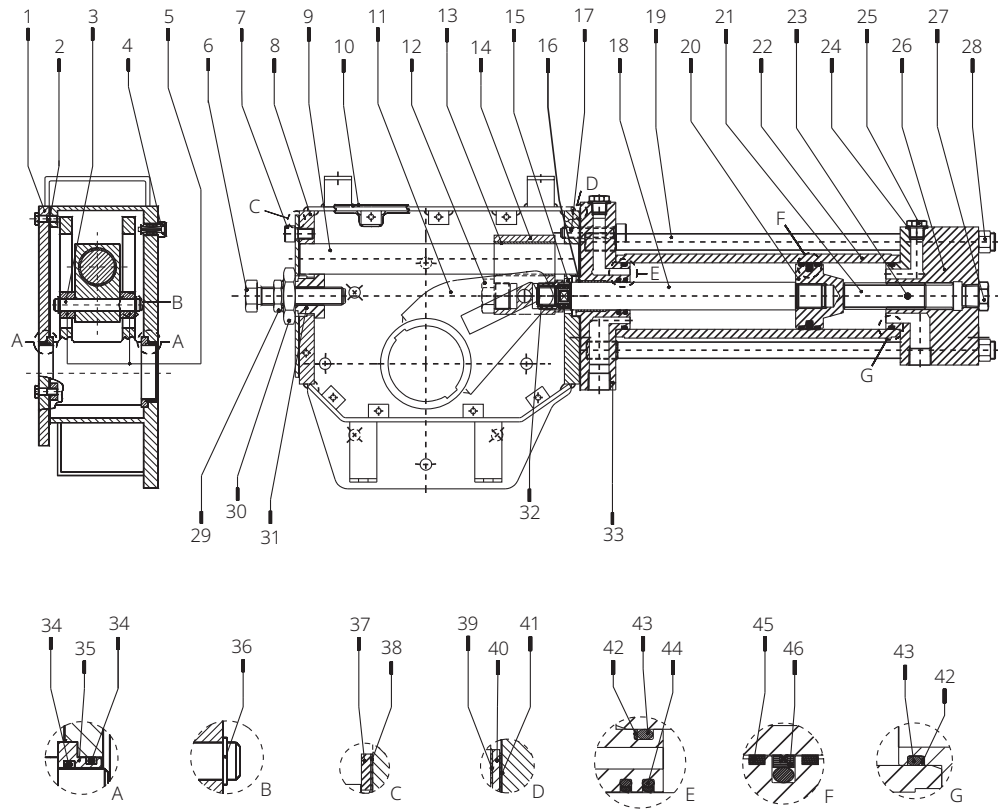

Table 11. Parts list

Item	Description	Item	Description
1	Cover	24	Washer
2	Screw	25	Plug
3	Guide block pin	26	End flange
4	Vent valve	27	Plug
5	Sliding block	28	Nut
6	-	29	-
7	-	30	-
8	Housing	31	-
9	Guide bar	32	Adaptor bush
10	Cover gasket	33	Head flange
11	Yoke	34	O-ring
12	Plug	35	Yoke bushing
13	Bushing	36	Retainer ring
14	Guide block	37	-
15	Washer	38	-
16	Piston rod bushing	39	Gasket
17	Screw	40	Flange
18	Piston rod	41	Gasket
19	Tie rod	42	Back-up ring
20	Piston	43	O-ring
21	Stop setting screw	44	Piston rod seal ring
22	Cylinder tube	45	Guide sliding ring for piston
23	Friction bar	46	Piston seal ring

5.2.2 Replacement of Seals for Actuators With Biffi Manual Hand Pump

See the following parts list for maintenance.

If there are leaks in the hydraulic cylinder or a malfunction in the mechanical components, or in case of scheduled preventive maintenance, the actuator must be disassembled and seals must be replaced with reference to the sectional drawing and adopting the following procedures:

1. Remove the nuts (item 16) and the washers (item 15) from the tie rods (item 10) at the end flange (item 13) side.
2. Slide off the end flange and the tube (item 12).
3. Remove the screws (item 2) and the cover (item 1).
4. Unscrew the piston rod (item 6) threaded end from the adaptor bush (item 30) of guide block (item 14).
5. Slide off the piston rod from the head flange (item 2).
6. Disassemble the head flange from the mechanism housing (item 8) by removing the screws (item 7) only if the gasket (item 36) has to be replaced because of damage.

5.2.2.1 Seals replacement

Prior to reassemble check that the actuator components are in good condition and is clean. Lubricate all the surfaces of the parts, which move in contact with other components, by recommended oil (ARNICA 22 or the oil used in the hydraulic cylinder). If the O-ring must be replaced, remove the existing one from its groove, clean the groove carefully and lubricate it with protective oil film. Assemble the new O-ring into its groove and lubricate it with a protective oil film.

1. Replace the O-ring (3) of the head flange (2).
2. Replace the O-ring (3) of the end flange (13).

For replacement of piston rod seal ring (4) and of the O-ring (5), proceed as follows:

1. Remove the existing PTFE seal ring (4) with its O-ring from their groove.
2. Clean the groove carefully and lubricate it with a protective oil film.
3. Assemble the new O-ring into its groove and lubricate it with a protective oil film.
4. Assemble the new PTFE seal ring (4) into the flange groove, on the rubber O-ring (5), by bending it; take care that the bending radius is as large as possible to avoid damaging the seal. Then, enlarge the seal ring with your fingers so as to restore its round shape; pay attention not to utilize any tools which can damage the seal ring.

To replace the piston dual-seal ring (9), proceed as follows:

1. Remove the existing dual-seal ring (9) with its O-ring from its groove.
2. Clean the groove carefully and lubricate it with a protective oil film.
3. Assemble the new dual-seal ring (9) by introducing one side of it into the groove and then enlarge it with your fingers so as to introduce it into the groove: take care to enlarge it uniformly without any tools which could possibly damage it. The elastic memory of the kind of PTFE type the seal ring is made of allows the ring to shrink back to its previous dimension after a short time.

If the O-ring (17) has to be replaced, measure the protrusion of the stop screw (11) with reference to the end flange (13) surface, so as to be able to easily restore the setting of the actuator mechanical stop in the open valve position, once the maintenance procedures have been completed.

4. Loosen the protection cover (14) and unscrew the stop screw (11) until it is removed.
5. Replace the O-ring (17) from the stop screw cover (14).
6. Screw the stop screw into the threaded hole of the end flange until it reaches its original position (the same protrusion with reference to the flange surface).
7. Tighten the protection cover (14).

5.2.2.2 Reassemble

1. Assemble the new gasket (item 36) after cleaning the surfaces of housing (item 8) and head flange (item 2) which are in contact.
2. Assemble the head flange and tighten the screws (item 7) to the recommended torque.
3. Clean and lubricate the piston rod (item 6) surface, particularly that of the bevel, with a protective oil or grease film and introduce it into the head flange hole, taking care not to damage the PTFE seal ring (item 4); the piston rod bevel has to enlarge smoothly the seal ring.
4. Carefully clean the threaded end of the piston rod and the threaded hole of the adaptor bush (item 30) of guide block (item 14). Spread some sealant LOCTITE 452, or equivalent, on the rod threaded end and screw it into the adaptor bush threaded hole and then tighten.
5. Carefully clean the inside of the tube (item 12) and check that the entire surface, particularly that of the bevels, is not damaged. Lubricate the tube inside surface and the bevels at the ends with protective oil or a grease film. Slide the tube onto the piston taking care not to damage the dual-seal ring (item 9); the tube bevel has to smoothly compress the seal ring.
6. Take care also not to damage the head flange O-ring (item 3).
7. Assemble the end flange (item 13) by centering it on the inside diameter of the tube, taking care not to damage the O-ring (item 3).
8. Assemble the washers (item 15) and the nuts (item 16) onto the tie rods (item 10). Tighten the nuts to the recommended torque, alternating between opposite corners.
9. Restore a generous coating of grease on the contact surfaces of the yoke (item 11) and the bushings (item 13), on the yoke grooves, on the sliding blocks (item 5), on guide bar (item 9).
10. Assemble the new gasket (item 36) after cleaning the surfaces of the housing (item 8) and cover (item 1).
11. Lubricate the O-ring with protective oil or grease (item 32).
12. Assemble the cover (item 1) and the screws (item 2). Tighten the screws to the recommended torque.

NOTICE

After maintenance operations, carry out a few actuator operations to check that its movement is regular and that there is no oil leakage through the seals.

Figure 31. Hydraulic Cylinder

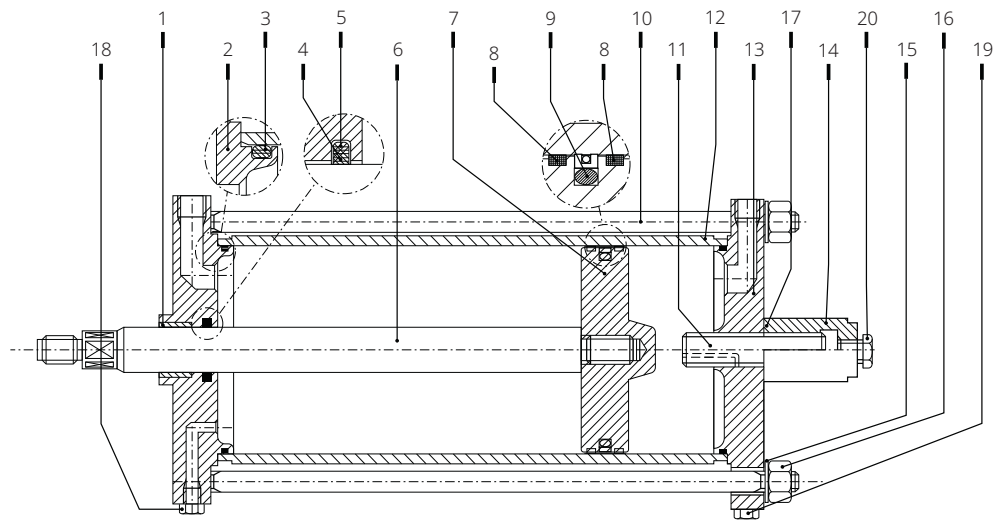

Table 12. Parts List

Item	Quantity	Description	Material
1	1	Piston rod bushing	Steel + Bz + PTFE
2	1	Head flange	Carbon steel
3	2	O-ring	* Nitrile Butadiene Rubber (NBR)
4	1	Piston rod seal ring	* PTFE + Graphite
5	1	O-ring	* NBR Rubber
6	1	Piston rod	Alloy steel
7	1	Piston	Nickel plated carbon steel
8	2	Guide sliding ring for piston	* PTFE + Graphite
9	1	Piston seal ring	* PTFE + NBR rubber
10	4	Tie rod	Alloy steel ASTM A320 Grade L7
11	1	Stop setting screw	Alloy steel
12	1	Cylinder tube	Nickel plated carbon steel
13	1	End flange	Carbon steel
14	1	Stop setting screw cover	Carbon steel ASTM A194 Grade 7
15	4	Spring washer	Carbon steel
16	4	Nut	Carbon steel ASTM A194 Grade 7
17	1	O-ring	* NBR rubber
18	6	Plug	Carbon steel
19	1	Plug	Carbon steel

NOTE:

*Recommended spare parts

5.3 Lubrication of Mechanism

For normal duty, the scotch yoke mechanism of the actuator is lubricated "for life". In case of high load and high frequency of operation, it may be necessary to periodically restore lubrication; it is advisable to apply a generous coating of grease on the contact surfaces of the yoke and bushings, on the yoke link grooves, on the sliding blocks, on the guide bar.

For this operation, it is necessary to disassemble the mechanism cover. In larger actuators, the lubrication can be performed through the inspection holes of the cover after removing the plugs.

The following grease is used by Biffi for standard working temperature and suggested for re-lubrication:

ENI MU/EP/2 *

To be used in standard temperature conditions: -30 to +85 °C

NLGI (National Lubricating Grease Institute) consistency:	2
Worked penetration:	280 dmm
ASTM Dropping Point:	185 °C
Base oil viscosity at 40 °C:	160 mm ² /s
ISO Classification:	L-X-BCHB 2
DIN 51 825:	KP2K - 20
Equivalent to:	Use an equivalent or better product in compliance with the grease proposed in the actual scope of supply by Biffi Fiorenzuola. Your grease supplier can verify and propose an alternative product at your responsibility.

Mobilgrease 33 or Equivalent **

To be used in low temperature conditions: -60 to +100 °C

Notes:

- * If the service is not special (i.e., oxygen, hydrogen or other mentioned during the offer stage).
- ** Use an equivalent or better product in compliance with the grease proposed in the actual scope of supply by Biffi Fiorenzuola. Your grease supplier can verify and propose an alternative product at your responsibility.

5.4 Dismantling and Demolition

Before starting the disassembly, a large area should be created around the actuator so as to allow any kind of movement without problems of further risks created by worksite.

WARNING

Before disassembling the actuator, it is necessary to close the hydraulic feed line and discharge oil pressure from the cylinder of the actuator, from the control unit and from the accumulator tank, if present.

If the actuator is still mounted onto the valve, loosen the threaded connections between valve and actuator (screws, tie rods, nuts).

Lift the actuator using the proper lifting points, see Section 2.2.

If the actuator needs storage, before demolition see Section 2.3.

WARNING

The demolition of the actuator both concerning any electrical and mechanical part should be made by specialized staff.

Separate the parts composing the actuator according to their nature (e.g., metallic and plastic materials, fluids, etc.) and send them to differentiated waste collection sites, as provided by the laws and provisions in force.

Section 6: Troubleshooting

6.1 Failure or Breakdown Research

Table 13.

Event	Possible Cause	Remedy
Actuator does not work	Lack of power supply	Restore it
	Lack of hydraulic supply	Open line interception valve
	Blocked valve	Repair or replace
	Wrong position of the distributor of the manual hydraulic group	Restore correct position
	Failure of the control group	Call Biffi Italia s.r.l. Customer Service
	Unexpected intervention of torque limit-device	Call Biffi Italia s.r.l. Customer Service
Actuator too slow	Low supply pressure	Restore (Section 1.4)
	Wrong calibration of flow regulator valves	Restore (Section 3.6)
	Bad functioning of quick exhaust valve	Call Biffi Italia s.r.l. Customer Service
	Wear of the valve	Replace
Actuator too fast	High supply pressure	Restore (Section 1.4)
	Wrong calibration of flow regulator valves	Restore (Section 3.6)
Leakages on hydraulic or pneumatic circuits	Deterioration and/or damage to gaskets	Call Biffi Italia s.r.l. Customer Service
Incorrect position of the valve	Wrong adjustment of mechanical stops	Restore (Section 3.4)
	Wrong warning of microswitches	Restore (Section 3.5)
Hydraulic manual pump does not work	Handle positioned on remote control	Position the handle on the indication of the operation to make
	Leakages on the check valve of the hydraulic control group	Call Biffi Italia s.r.l. Customer Service

Section 7: Spare Parts

7.1 Spare Parts Order

For spare parts orders to the relevant Biffi office, please make reference to Biffi order confirmation concerning all the supply and serial number of the actuator (Section 1.2) for any specific spare parts for a specific actuator model.

Please send all spare parts request to :

Biffi Italia s.r.l. - Spare Parts and After Sales Department

Tel. : +39 0523-944523

Fax: +39 0523-941885

E-mail: Biffispares@Emerson.com

Please specify :

1. Actuator model
2. Biffi acknowledgement
3. Spare parts code
4. Quantity
5. Transport condition
6. Involved people

7.2 Parts List for Maintenance and Replacing Procedure

Figure 32. Scotch Yoke Mechanism

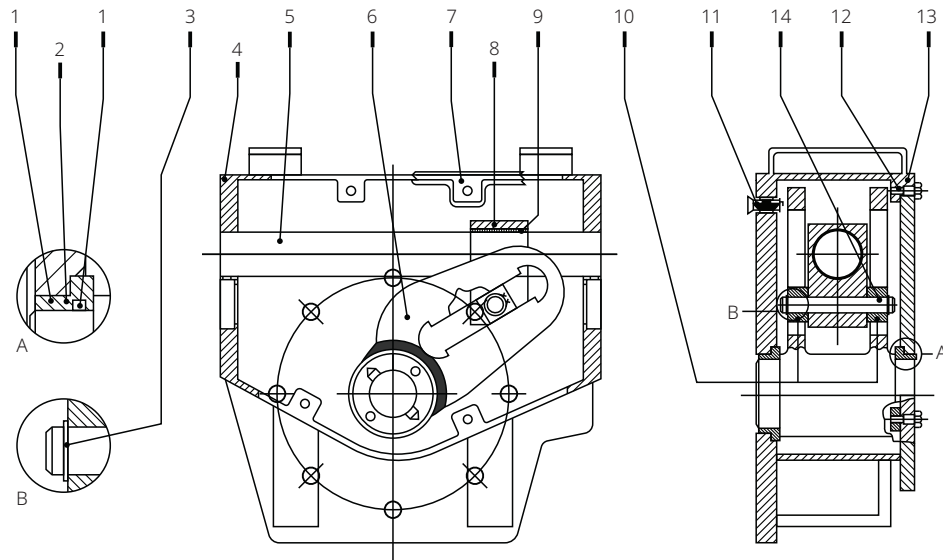

Table 14. Parts List

Item	Quantity	Description	Material
1	4	O-ring	* NBR
2	2	Yoke bushing	Bronze
3	2	Retainer ring	Stainless steel
4	1	Housing	Carbon steel
5	1	Guide bar	Alloy steel
6	1	Yoke	Carbon steel
7	1	Cover gasket	* Fiber
8	1	Guide block	Carbon steel
9	1	Bushing	Steel + Bz + PTFE
10	2	Sliding block	Bronze
11	1	Vent valve	* Stainless steel
12	12	Screw	Carbon steel
13	1	Cover	Carbon steel
14	1	Guide block pin	Alloy steel

NOTE:

*Recommended spare parts

Figure 33. Hydraulic Cylinder

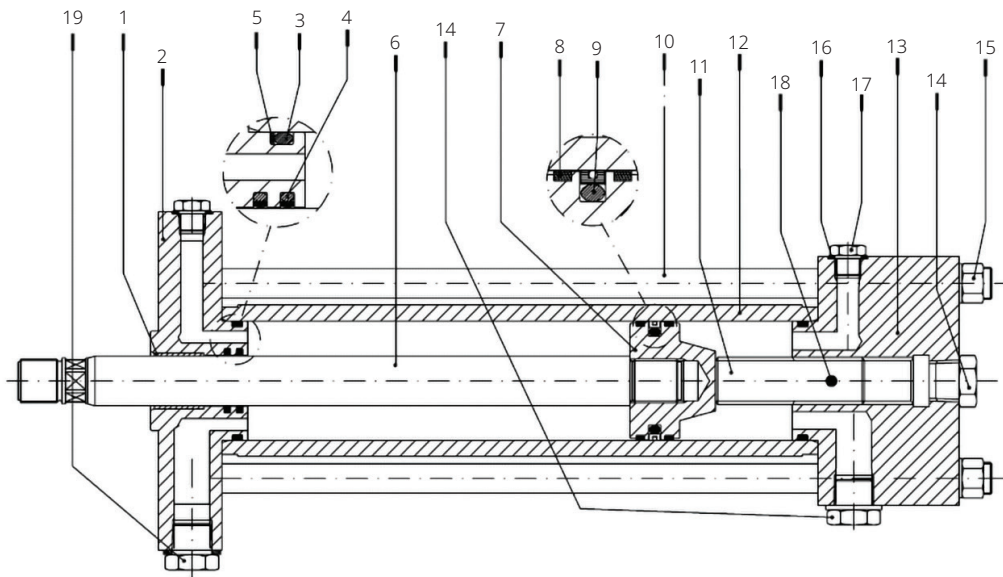
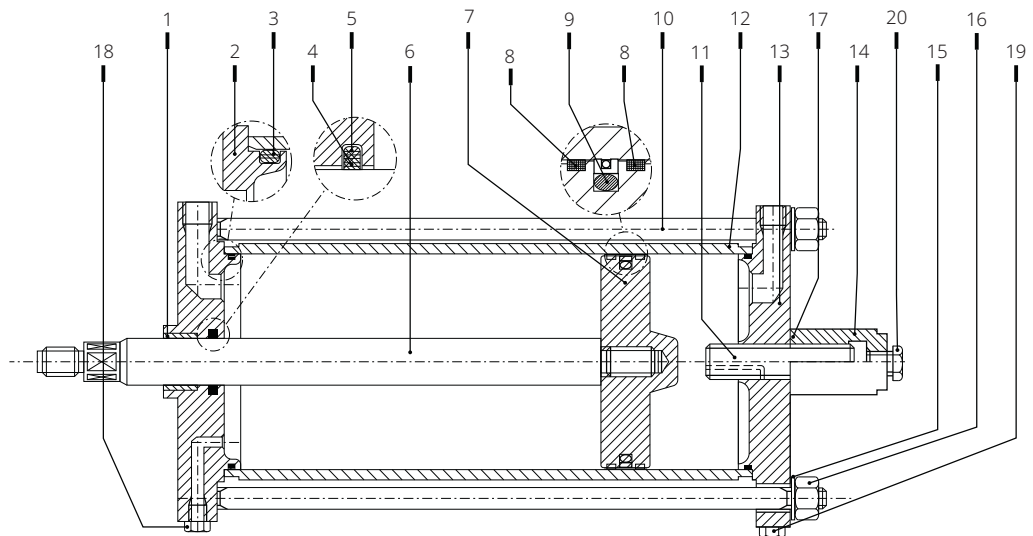

Table 15. Parts List

Item	Quantity	Description	Material
1	1	Piston rod bushing	Steel + Bz + PTFE
2	1	Head flange	Nickel plated carbon steel
3	2	O-ring	*NBR rubber
4	2	Piston rod seal ring	*PTFE + Graphite + NBR
5	2	Back-up ring	*NBR Rubber
6	1	Piston rod	Chromium plated alloy steel
7	1	Piston	Carbon steel
8	2	Guide sliding ring for piston	* PTFE + Graphite
9	1	Piston seal ring	* PTFE + Graphite + NBR rubber
10	4	Tie rod	Carbon steel ASTM A320 Grade L7
11	1	Stop setting screw	Carbon steel
12	1	Cylinder tube	Nickel plated carbon steel
13	1	End flange	Nickel plated carbon steel
14	2	Plug	Carbon steel
15	4	Nut	Carbon steel ASTM A194 Grade 7
16	4	Washer	Alloy Steel or carbon steel
17	4	Plug	Stainless steel
18	1	Friction bar	Nylon
19	1	Plug	Stainless steel

NOTE:

*Recommended spare parts

Figure 34. Hydraulic Cylinder for MHP (Optional)**Table 16. Parts List**

Item	Quantity	Description	Material
1	1	Piston rod bushing	Steel + Bz + PTFE
2	1	Head flange	Carbon steel
3	2	O-ring	* NBR rubber
4	1	Piston rod seal ring	* PTFE + Graphite
5	1	O-ring	* NBR Rubber
6	1	Piston rod	Alloy steel
7	1	Piston	Nickel plated carbon steel
8	2	Guide sliding ring for piston	* PTFE + Graphite
9	1	Piston seal ring	* PTFE + NBR rubber
10	4	Tie rod	Alloy steel ASTM A320 Grade L7
11	1	Stop setting screw	Alloy steel
12	1	Cylinder tube	Nickel plated carbon steel
13	1	End flange	Carbon steel
14	1	Stop setting screw cover	Carbon steel
15	4	Spring washer	Carbon steel
16	4	Nut	Carbon steel ASTM A194 Grade 7
17	1	O-ring	* NBR rubber
18	6	Plug	Carbon steel
19	1	Plug	Carbon steel
20	1	Plug	Carbon steel

NOTE:

*Recommended spare parts

Figure 35. Assembly Kit

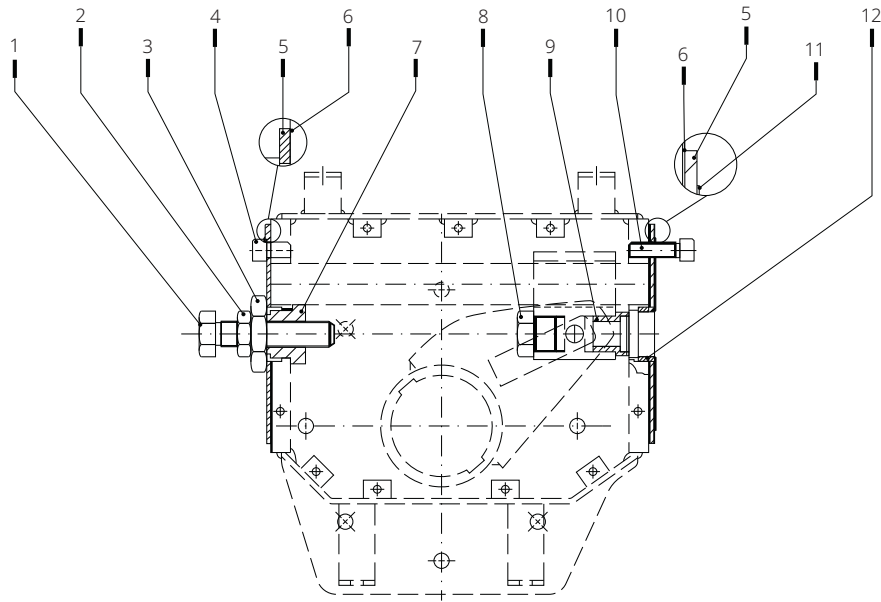

Table 17. Parts List

Item	Quantity	Description	Material
1	1	Screw	Alloy steel
2	1	Nut	Carbon steel
3	1	Nut	Carbon steel
4	4	Screw	Alloy steel
5	2	Flange	Carbon steel
6	2	Gasket	* Fiber
7	1	Stopper bush	Alloy steel
8	1	Plug	Alloy steel
9	1	Adaptor bush	Alloy steel
10	4	Screw	Alloy steel
11	1	Gasket	* Fiber
12	1	Washer	Alloy steel

NOTE:
*Recommended spare parts

Figure 36. Hydraulic Control Unit MHP

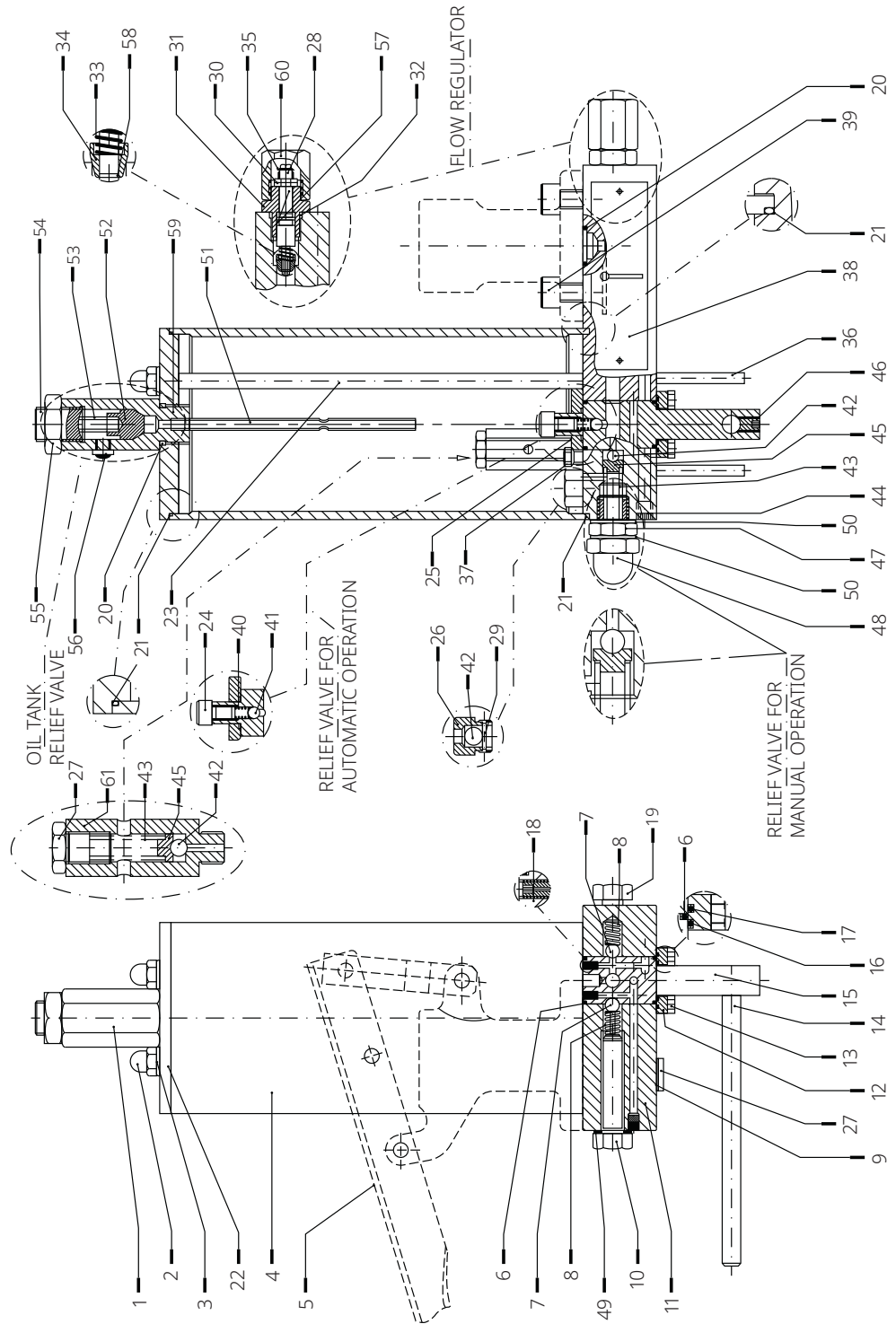
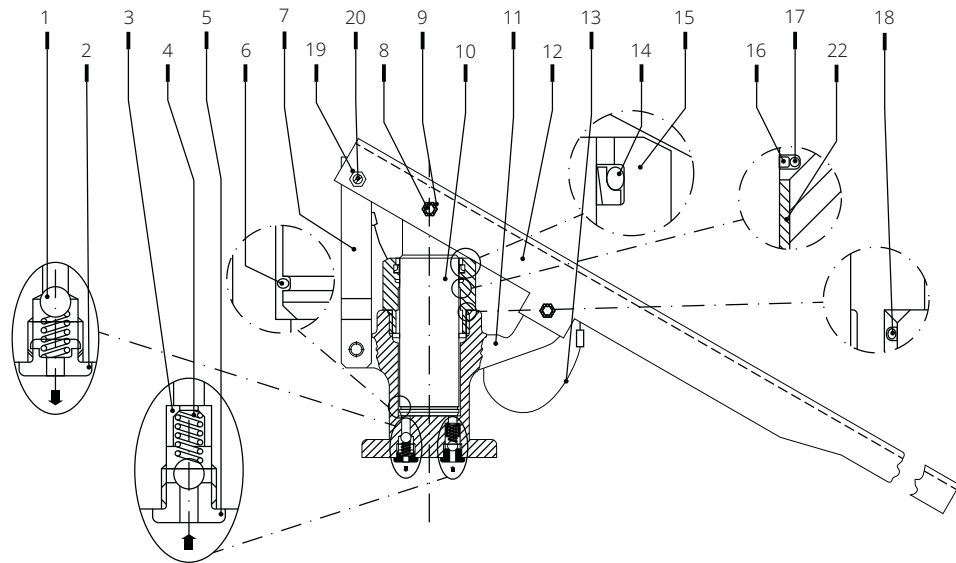

Table 18. Parts List

Item	Quantity	Description	Material
1	1	Dipstick	-
2	2	Cap nut	Carbon steel
3	2	Washer	Carbon steel + rubber
4	1	Hydraulic tank	Carbon steel
5	1	Hand Pump	See Table 19
6	2	O-ring	* Fluorosilicon rubber
7	2	Ball	Stainless steel
8	2	Spring	Spring steel
9	1	Washer	Carbon steel + rubber
10	1	Screw	Carbon steel
11	1	Plate	Carbon steel
12	1	Flange	Aluminum
13	4	Screw	Carbon steel
14	1	Lever	Carbon steel
15	1	Distributor	Stainless steel
16	1	O-ring	* Fluorosilicon rubber
17	1	O-ring	* Fluorosilicon rubber
18	1	Nozzle	Carbon steel
19	2	Screw	Carbon steel
20	3	O-ring	* Fluorosilicon rubber
21	2	O-ring	* Fluorosilicon rubber
22	1	Tank cover	Carbon steel
23	2	Tie rod	Carbon steel
24	1	Screw	Carbon steel
25	1	Flange	Aluminum
26	2	Check valve body	Aluminum
27	2	Plug	Carbon steel
28	2	Flow control valve setting screw	Stainless steel
29	2	Spring pin	Stainless steel
30	2	Nut	Carbon steel
31	2	Flange	Carbon steel
32	2	O-ring	* Fluorosilicon rubber
33	2	Spring	Spring steel
34	2	Plug	Stainless steel
35	2	Retainer ring	Spring steel
36	2	Spring pin	Carbon steel
37	4	Screw	Carbon steel
38	1	Operation instruction plate	Stainless steel
39	4	Screw	Carbon steel
40	1	Spring	Stainless steel
41	1	Ball	Stainless steel
42	4	Ball	Stainless steel
43	2	Spring	Spring steel
44	1	Relief valve setting screw	Stainless steel
45	2	Spring pin	Carbon steel
46	1	Screw	Alloy steel
47	1	Spring	Stainless steel
48	1	Nut	Carbon steel
49	1	Washer	Carbon steel + rubber
50	2	Washer	Carbon steel + rubber
51	1	Dipstick	Stainless steel
52	1	Plug + O-ring	-
53	1	Spring	Stainless steel
54	1	Screw	Alloy steel
55	1	Nut	Carbon steel
56	1	Silencer	Brass
57	2	O-ring	* Fluorosilicon rubber
58	2	Retainer ring	Spring steel
59	1	Dipstick body	Aluminum
60	2	Nut	Carbon steel
61	1	Relief valve body	Aluminum

NOTE:

*Recommended spare parts

Figure 37. Hand Pump**Table 19. Parts List**

Item	Quantity	Description	Material
1	2	Ball	Stainless steel
2	1	Delivery valve bush	Carbon steel
3	1	Suction valve bush	Carbon steel
4	2	Spring	Stainless steel
5	1	Suction valve seat	Carbon steel
6	1	Spring retainer ring	Carbon steel
7	1	Fork	Carbon steel
8	2	Pin	Stainless steel
9	4	Retainer ring	Carbon steel
10	1	Rod	Alloy steel
11	1	Body	Carbon steel
12	1	Lever	Carbon steel
13	1	Split pin with rope	Nylon + Carbon steel
14	1	Scraper ring	* PTFE + Fluorosilicon rubber
15	1	Threaded ring	Aluminum
16	2	Rod seal ring	* PTFE + Graphite
17	2	O-ring	* Fluorosilicon rubber
18	1	O-ring	* Fluorosilicon rubber
19	1	Nut	Carbon steel
20	1	Screw	Carbon steel
21	1	Fork	Carbon steel
22	1	Piston rod bushing	Steel + Bz + PTFE

NOTE:

*Recommended spare parts

Figure 38. Jackscrew Manual Override MSJ

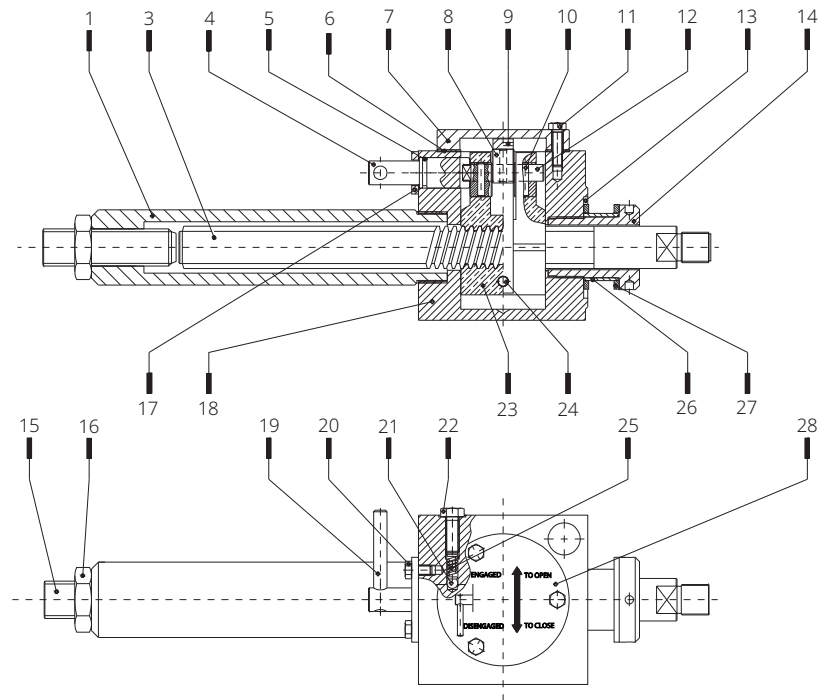

Table 20. Parts List

Item	Quantity	Description	Material
1	1	Protection pipe	Carbon steel
2	-	-	-
3	1	Jack screw	Carbon steel
4	1	Engagement lever pin	Stainless steel
5	1	O-ring	* Fluorosilicon rubber
6	1	Cover gasket	* Fiber
7	1	Cover	Carbon steel
8	3	Cam	Alloy steel
9	1	Fork	Carbon steel
10	3	Spring pin	Stainless steel
11	3	Screw	Carbon steel
12	1	Screw nut operating cam	Alloy steel
13	1	O-ring	* Fluorosilicon rubber
14	1	Thrust block ring nut	Alloy steel
15	1	Screw	Carbon steel
16	1	Nut	Carbon steel
17	1	Flange	Carbon steel
18	1	Body	Carbon steel
19	1	Spring pin	Spring steel
20	2	Screw	Carbon steel
21	1	Ball 1/4 in	Stainless steel
22	1	Screw	Carbon steel
23	1	Screw nut	Bronze
24	1	Pin	Carbon steel
25	1	Spring	Spring steel
26	1	Bush	Bronze
27	2	Thrust shoulder washer	Bronze
28	1	Operating instruction plate	Aluminum

NOTE:
*Recommended spare parts

Section 8: Date Report for Maintenance Operations

Last maintenance operation date: (in factory, on delivery):
..... exec. by :
..... exec. by :
..... exec. by :

Next maintenance operation date: exec. by :
..... exec. by :
..... exec. by :

Start-up date:(in factory, on delivery).....
..... (on plant).....

This page is intentionally left blank.

Biffi Italia s.r.l.
Strada Biffi 165
29017 Fiorenzuola d'Arda (PC)
Italy
T +39 0523 944 411

For complete list of sales and manufacturing sites, please visit
www.biffi.it or contact us at biffi_italia@biffi.it

VCIOM-03744-EN © 1999, 2024 Biffi. All rights reserved.

The contents of this publication are presented for informational purposes only, and while every effort has been made to ensure their accuracy, they are not to be construed as warranties or guarantees, express or implied, regarding the products or services described herein or their use or applicability. All sales are governed by our terms and conditions, which are available upon request. We reserve the right to modify or improve the designs or specifications of such products at any time without notice.

