

# Biffi ICON3000

EleHRT-24 HART Bus Module



*This page is intentionally left blank.*

# Table of Contents

## Section 1: Introduction

Introduction ..... 1

## Section 2: Operation and Storage

Operation and Storage ..... 2

## Section 3: Communication Features

Communication Features ..... 3

## Section 4: HART Module

4.1 On Board Indications and Jumpers ..... 5  
 4.2 Analog Control Signal ..... 6  
 4.3 Process Variables ..... 6

## Section 5: HART Protocol Previews

5.1 HART Wirings ..... 8

## Section 6: Wiring and Installation

6.1 Cable Length ..... 10  
 6.2 Shielding and Grounding ..... 10

## Section 7: HART Commands

HART Commands ..... 11

## Section 8: HART Command Set

8.1 Universal Commands ..... 14  
 8.1.1 Command #0: Read Unique Identifier ..... 14  
 8.1.2 Command #1: Read Primary Variable ..... 15  
 8.1.3 Command #3: Read Dynamic Variables and Loop Current ..... 16  
 8.1.4 Command #2: Read Loop Current and Percent of Range ..... 16  
 8.1.5 Command #6: Write Polling Address ..... 17  
 8.1.6 Command #7: Read Loop Configuration ..... 18  
 8.1.7 Command #8: Read Dynamic Variable Classifications ..... 18  
 8.1.8 Command #9: Read Device Variables with Status ..... 19  
 8.1.9 Command #11: Read Unique Identifier Associated with Tag ..... 21  
 8.1.10 Command #13: Read Tag, Descriptor, Date ..... 22  
 8.1.11 Command #12: Read Message ..... 22  
 8.1.12 Command #14: Read Primary Variable  
 Transducer Information ..... 23  
 8.1.13 Command #15: Read Device Information ..... 23  
 8.1.14 Command #16: Read Final Assembly Number ..... 24  
 8.1.15 Command #17: Write Message ..... 24  
 8.1.16 Command #18: Write Tag, Descriptor, Date ..... 25  
 8.1.17 Command #19: Write Final Assembly Number ..... 26  
 8.1.18 Command #20: Read Long Tag ..... 26  
 8.1.19 Command #21: Read Unique Identifier Associated  
 with Long Tag ..... 27

8.1.20	Command #22: Write Long Tag .....	28
8.1.21	Command #38: Reset Configuration Changed Flag .....	28
8.1.22	Command #48: Read Additional Device Status .....	29
8.2	Common Practice Commands .....	33
8.2.1	Command #50: Read Dynamic Variable Assignments .....	33
8.2.2	Command #51: Write Dynamic Variable Assignments .....	34
8.2.3	Command #54: Read Device Variable Information .....	36
8.2.4	Command #59: Write Number of Response Preambles .....	37
8.2.5	Command #95: Read Device Communication Statistics .....	38
8.2.6	Command #103: Write Burst Period .....	39
8.2.7	Command #104: Write Burst Trigger .....	40
8.2.8	Command #105: Read Burst Mode Configuration .....	42
8.2.9	Command #107: Write Burst Device Variables .....	43
8.2.10	Command #108: Write Burst Mode Command Number .....	44
8.2.11	Command #109: Burst Mode Control .....	45
8.2.12	Catch Device Variable .....	45
8.3	Device-Specific Commands .....	46
8.3.1	Command #130: Read Array .....	47
8.3.2	Command #131: Write Array .....	47
8.3.3	Command #132: Read Param_E Parameters .....	48
8.3.4	Command #133: Write Param_E Parameters .....	49
8.3.5	Command #134: Read Param_BE Parameters .....	50
8.3.6	Command #135: Write Param_BE Parameters .....	51
8.3.7	Command #136: Read Param_F Parameters .....	52
8.3.8	Command #137: Write Param_F Parameters .....	53
8.3.9	Command #138: Read Param_D Parameters .....	54
8.3.10	Command #139: Write Param_D Parameters .....	55
8.3.11	Command #140: Read Param_U32 Parameters .....	56
8.3.12	Command #141: Write Param_U32 Parameters .....	57
8.3.13	Command #142: Read Param_S32 Parameters .....	58
8.3.14	Command #143: Write Param_S32 Parameters .....	59
8.3.15	Command #144: Read Param_Str8 Parameters .....	60
8.3.16	Command #145: Write Param_Str8 Parameters .....	61
8.3.17	Command #146: Read Param_Str4 Parameters .....	62
8.3.18	Command #147: Write Param_Str4 Parameters .....	63
8.3.19	Command #148: Read FST Torque Curve Data Header .....	64
8.3.20	Command #149: Read FST Torque Curve .....	65
8.3.21	Command #150: Read PST Curve Data Header .....	68
8.3.22	Command #151: Read PST Curve Part1 .....	69
8.3.23	Command #152: Read PST Curve Part2 .....	71
8.3.24	Command #153: Read EFS Curve Data Header .....	73
8.3.25	Command #154: Read EFS Curve Part1 .....	74
8.3.26	Command #155: Read EFS Curve Part2 .....	76
8.3.27	Command #156: Read Event Log Data Header .....	78
8.3.28	Command #157: Read Event Log .....	79
8.3.29	Command #158: Read Recorder Log Data Header .....	80
8.3.30	Command #159: Read Recorder Log .....	81
8.3.31	Command #160: Read T-Recorder Log Data Header .....	82
8.3.32	Command #161: Read T-Recorder Log .....	83
8.3.33	Command #162: Read Card Report .....	84
8.3.34	Command #163: Write Card Report .....	85
8.3.35	Command #164: Read Alarms, Warnings and Connection Logs Data Header .....	86
8.3.36	Command #165: Read Alarms Log .....	87
8.3.37	Command #166: Read Warnings Log .....	88
8.3.38	Command #167: Read Connections Log .....	89

8.3.39 Command 168: Read Actuator Commands ..... 90  
 8.3.40 Command 169: Write Actuator Commands ..... 90  
 8.3.41 Command 171: Read Actuator Status ..... 91  
 8.3.42 Command 172: Read PST Status ..... 92  
 8.3.43 Common Tables ..... 93

**Section 9: Device Variables**

9.1 List of Device Variables ..... 97  
 9.2 Device Variable Status Byte ..... 98  
 9.3 Device Variables ..... 98  
     9.3.1 Device Variable 0: Analog Position Request ..... 98  
     9.3.2 Device Variable 1: Actuator Position ..... 98  
     9.3.3 Device Variable 2: Torque ..... 98  
     9.3.4 Device Variable 3: Temperature ..... 98  
     9.3.5 Device Variable 4: Motor Speed ..... 99  
     9.3.6 Device Variable 5: Main Voltage ..... 99  
     9.3.7 Device Variable 6: Current ..... 99  
     9.3.8 Device Variable 7: Motor Temperature ..... 99  
     9.3.9 Device Variable 8: Terminal Board Temperature ..... 99  
     9.3.10 Device Variable 9: Position Request (used by Logic Card) ..... 99  
     9.3.11 Device Variable 10: Auxiliary Analog Input (mA) ..... 99  
     9.3.12 Device Variable 11: Auxiliary Analog Input (bit) ..... 99  
     9.3.13 Device Variable 12: Analog Output (mA) ..... 99  
     9.3.14 Device Variable 13: Analog Output (bit) ..... 99  
     9.3.15 Device Variable 14: Local Mode ..... 99  
     9.3.16 Device Variable 15: Off Mode ..... 99  
     9.3.17 Device Variable 16: Remote Mode ..... 100  
     9.3.18 Device Variable 17: Stall Alarm ..... 100  
     9.3.19 Device Variable 18: Device Alarm Active ..... 100  
     9.3.20 Device Variable 19: Actuator Ready ..... 100  
     9.3.21 Device Variable 20: Open Limit ..... 100  
     9.3.22 Device Variable 21: Close Limit ..... 100  
     9.3.23 Device Variable 22: Opening ..... 100  
     9.3.24 Device Variable 23: Closing ..... 100  
     9.3.25 Device Variable 24: Stopped ..... 100  
     9.3.26 Device Variable 244: Percent Range ..... 100  
     9.3.27 Device Variable 245: Loop Current ..... 101  
     9.3.28 Device Variable 246: Primary Variable ..... 101  
     9.3.29 Device Variable 247: Secondary Variable ..... 101  
     9.3.30 Device Variable 248: Tertiary Variable ..... 101  
     9.3.31 Device Variable 249: Quaternary Variable ..... 101

## Section 10: Tables

10.1	Array Codes.....	102
10.2	Param_E Parameters Codes (Enumerated).....	103
10.3	Param_BE Parameters Codes (Bit Enumerated) .....	110
10.4	Param_F Parameters Codes (Float).....	111
10.5	Param_D Parameters Codes (Date) .....	111
10.6	Param_U32 Parameters Codes (Unsigned Int-32) .....	112
10.7	Param_S32 Parameters Codes (Signed Int-32) .....	115
10.8	Param_Str8 Parameters Codes (String8).....	116
10.9	Param_Str4 Parameters Codes (String4).....	116
10.10	FST Torque Curve ID.....	116
10.11	FST Torque Type.....	116
10.12	PST Curve ID .....	117
10.13	PST Result.....	117
10.14	PST Direction/EFS Direction.....	117
10.15	PST Mode.....	117
10.16	PST Status.....	118
10.17	PST Reset Conditions .....	118
10.18	EFS Curve ID.....	118
10.19	Memory Mode .....	119
10.20	Event Number.....	119
10.21	Event Code .....	119
10.22	Recorder Number .....	119
10.23	T-Recorder Number.....	119
10.24	Card ID .....	120
10.25	Event Source .....	120
10.26	Alarm Number .....	120
10.27	Warning Number .....	121
10.28	Alarm Code.....	121
10.29	Warning Code.....	122
10.30	Connection Number.....	122
10.31	Password Level.....	122
10.32	Connection Type .....	122
10.33	Actuator Commands.....	123
10.34	Actuator Status 1 .....	123
10.35	Actuator Status 2 .....	123
10.36	Actuator Status 3 .....	124
10.37	Actuator Status 4 .....	124
10.38	Actuator Status 5 .....	124
10.39	Actuator Status 6 .....	125
10.40	Heater Status.....	125
10.41	Digital Inputs Status.....	125
10.42	Output Contacts Status 1 .....	126
10.43	Output Contacts Status 2.....	126
10.44	DIN Status.....	126
10.45	K1 Contactor Status.....	127
10.46	K2 Contactor Status.....	127
10.47	Motor Thermostat Status.....	127
10.48	HART Interface Status.....	127
10.49	Alarms 1 .....	128
10.50	Alarms 2 .....	128

10.51	Alarms 3	128
10.52	Alarms 4	129
10.53	Warnings 1	129
10.54	Warnings 2	129
10.55	Encoder Status 1	130
10.56	Encoder Status 2	130
10.57	User Level Logged	130
10.58	Last PST Status	130
10.59	Last PST Reset Conditions 1	131
10.60	Last PST Reset Conditions 2	131
10.61	Last PST Reset Conditions 3	131

## Section 11: Configuration via Local Interface

11.1	BUS Control	132
11.2	Positioner Function	134
11.3	Fail-Safe Function	135
11.4	Viewing Transmission Info	136
11.5	Actuator Terminal Board	136
11.6	Bus Signal Failure Indication	138

## Section 12: Certificate of Registration

	Certificate of Registration	139
--	-----------------------------	-----

## Appendix A: HART Command 3 Communication Example

	HART Command 3 Communication Example	140
--	--------------------------------------	-----

## Appendix B: Writing Variables and Parameters Data

	Writing Variables and Parameters Data	142
--	---------------------------------------	-----

## Appendix C: Configuration Requirements for | PST Command

	Configuration Requirements for   PST Command	143
--	--	-----

*This page is intentionally left blank.*

## Section 1: Introduction

The EleHRT-24 Module is an electronic module that allows connecting the Biffi™ ICON3000 v2 actuator families to a HART® serial communication line. The module complies with HART Protocol Revision 7, it is controlled by a program stored internally, it works as a pure bus interface, and does not affect the actuator control integrity. It is installed inside the actuator housing and takes the electrical power from the actuator power supply module. The HART hardware modem is located on the module board. The data lines are fully isolated from the actuator electronics.

The ICON3000 v2 actuator can be recognized because when it is switched on, the name ICON3000 v2 appears on the local screen, as shown in Figure 1.

**Figure 1.** Display



# Section 2: Operation and Storage

The module is designed to work and to be stored in the same environment of the actuator.

## Section 3: Communication Features

<b>Communication Protocol:</b>	HART Protocol Revision 7.9	
<b>Electrical Interface:</b>	4 to 20 mA analog loop, 2 wire communication	
<b>HART Signal:</b>	Digital FSK Frequency Shift Keying (Bell 202 standard)	
<b>Logical "0" Frequency:</b>	2200 Hz	
<b>Logical "1" Frequency:</b>	1200 Hz	
<b>Data Rate:</b>	Request/response mode – 2/3 updates per second Optional burst mode – 3/4 updates per second	
<b>Data Transmission:</b>	Master/Slave and Burst communication modes	
<b>Data Byte Structure:</b>	1 start bit, 8 data bits, 1 odd parity bit, 1 stop bit	
<b>Command Structure:</b>	<b>Type of Command</b>	<b>Structure</b>
	Universal	Common to all devices
	Common practice	Optional; used by many devices
	Device-specific	For unique product features
<b>HART Topology:</b>	Point to point, Multidrop, Series Connection	
<b>Cable Lengths:</b>	Maximum twisted pair length – 3048 m / 10,000 ft Maximum multiple twisted pair length – 1524 m / 5000 ft	
<b>Electrical Power:</b>	Bus powered	
	Maximum voltage	36 V
	Minimum voltage	0 V
<b>Device Type:</b>	Actuator	
<b>Device Impedance:</b>	Low Impedance	
<b>Temperature:</b>	-40 °C, +85 °C	
<b>Reversed Polarity Protection:</b>	Present	
<b>Manufacturer ID Code:</b>	183 (B7 HEX)	
<b>Device Type Code:</b>	127 (7F HEX)	

# Section 4: HART Module

The module consists in a single PCB that is installed inside the actuator housing. It is connected to the base card via strip connector.

The internal wiring connects the HART data lines to the actuator terminal board.

**Figure 2. Top Side - EleHRT-24 Rev. 1 Interface**

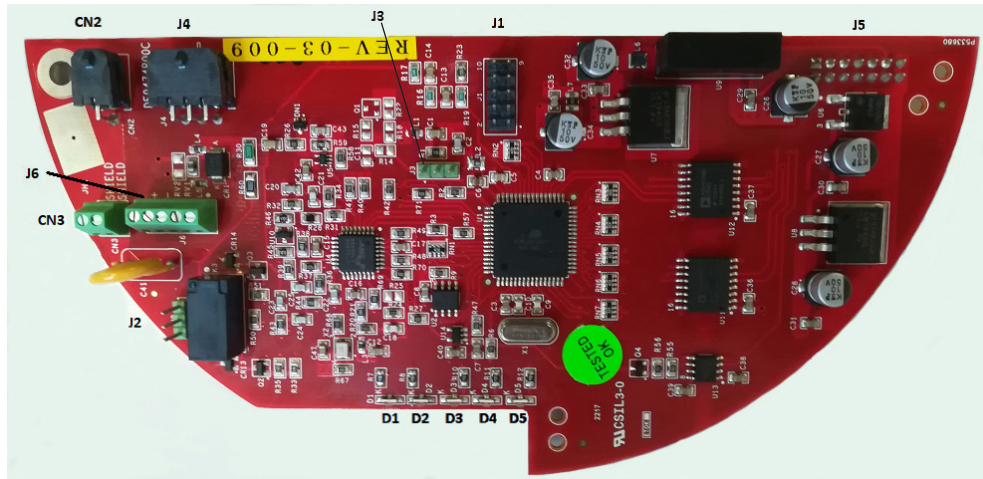

**Figure 3. Bottom Side - EleHRT-24 Rev. 1 Interface**

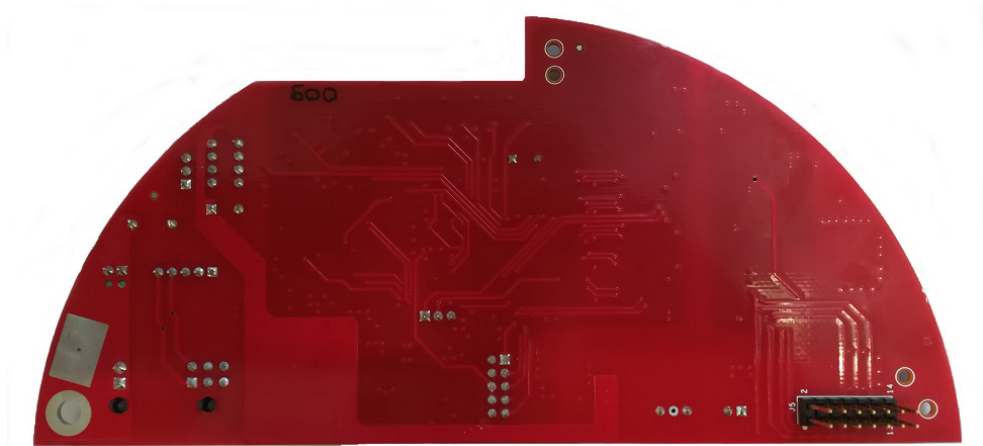

## 4.1 On Board Indications and Jumpers

Five LEDs are mounted on the EleHRT-24 to give the following indications for the field service.

**DL1 (red) Base Communication Status:**

ON: when communication issues are faced during the communication with the logic card

OFF: when the communication with the logic card works fine

**DL2 (green) Data Area Empty:**

ON: when Data area on EleHRT-24 card is empty

OFF: when Data area on EleHRT-24 card is not empty

**DL3 (green) Modbus Communication Status:**

FIXED ON/OFF: when Modbus communication issues are faced during the communication with the logic card

BLINK: no Modbus communication issues are faced during the communication with the logic card

**DL4 (green) HART Communication Status:**

BLINK: Communication active

FIXED ON/OFF: Communication not active

**DL5 (green) Power Supply:**

ON: EleHRT-24 module is correctly powered from the main power supply.

OFF: EleHRT-24 module is not correctly powered from the main power supply

**J1:**

It is used to download the FW on the microcontroller (manufacturer use only).

**J2:**

Reserved for manufacturer

**J3:**

Reserved for manufacturer

## 4.2 Analog Control Signal

Maximum Current:	22 mA
Minimum Current:	2 mA
Multidrop Current:	0 mA (no current flows)

The following values are measured according to the HCF\_TEST-2 rev 2.2.

Input Impedance:	485 $\Omega$ (in loop control mode)
Input Capacitance:	5000 pF (in loop control mode)

## 4.3 Process Variables

PV:	Analog 4 to 20 mA signal in % (position request in loop enable mode)
PV loop current:	Analog 4 to 20 mA input signal in mA
SV:	Actuator position in % of opening
TV:	Actuator torque in % of nominal torque (+ in closing, - in opening)
QV:	Temperature of electronics ( $^{\circ}\text{C}$ )

The process variables can be changed by Command #51, see Section 8.2.2 for details.

# Section 5: HART Protocol Previews

The HART bus combines the familiarity of using the 4 to 20 mA signals with the benefits of the bus technology. In fact, by means of the simultaneous analog and digital signals, additional information can be carried out on the same pair of wires together with the analog 4 to 20 mA signal. The digital communication signal has a response time of approximately 2 to 3 data updates per second without interrupting the analog signal.

HART is typically a request-response communication protocol, which means that during normal operation (2 to 3 data updates per second), each field device communication is initiated by a host communication device. Two hosts can connect to each HART loop. The primary host is generally a distributed control system (DCS), programmable logic controller (PLC), or a personal computer (PC). Our actuator interface is a field device.

The EleHRT-24 Module supports the optional burst communication mode. Burst mode enables faster communication (3 to 4 data updates per second). In burst mode, the host instructs the field device to continuously broadcast a standard HART reply message (e.g., the value of the process variable). The host receives the message at the higher rate until it instructs the device to stop bursting.

The HART Communication Protocol is based on the Bell 202 telephone communication standard and operates using the Frequency Shift Keying (FSK) principle. The digital signal is made up of two frequencies 1200 Hz and 2200 Hz representing bits 1 and 0, respectively. Sine waves of these two frequencies are superimposed on the direct current analog signal cables to provide simultaneous analog and digital communications. Because the average value of the FSK signal is always zero, the 4 to 20 mA analog signal is not affected.

**Figure 4. Digital Over Analog**

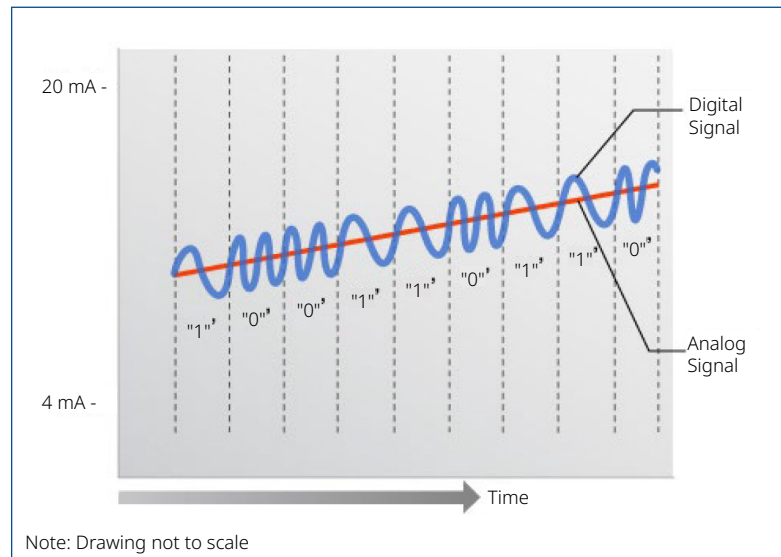

More information about HART is available on the website <https://www.fieldcommgroup.org/>.

## 5.1 HART Wirings

According to HART specification, the following working modes are available: point to point, split range, multidrop.

The selection is managed by the device according with the actuator settings (see MODE and HART RELAY in Section 11.1).

- **POINT TO POINT**

In Point to Point mode, the 4 to 20 mA signal is used to communicate one process variable, while additional process variables, configuration parameters, and other device data are transferred digitally using the HART Protocol. The 4 to 20 mA analog signal is not affected by the HART signal and can be used for control. The HART communication digital signal gives access to secondary variables and other data that can be used for operations, commissioning, maintenance and diagnostic purposes.

**Figure 5. Point to Point Connection**

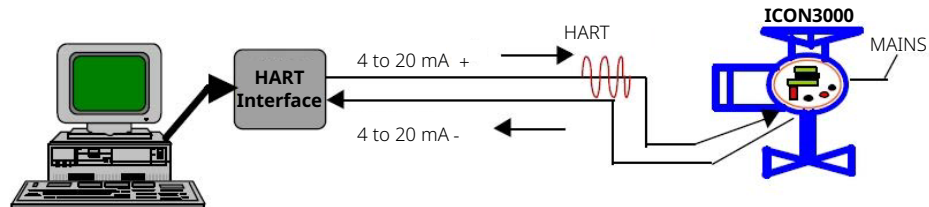

- **SPLIT RANGING**

Split Range Control is a single control loop divided into two or more independent final control elements such as valves acting in different directions or in different steps. The field devices are connected in series in the same 4 to 20 mA current loop, each field device must have a unique polling address, different from each other in the range 0 to 15.

**Figure 6. Split Ranging Connection**

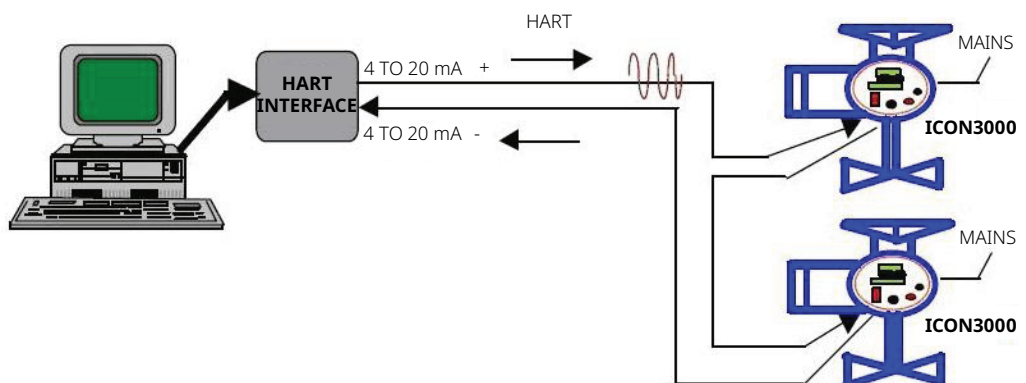

- **MULTIDROP**

The Multidrop Mode requires only a single pair of wires and can control up to 16 devices connected in parallel. All process values are transmitted digitally. In Multidrop mode, each field device must have a unique polling address, different from each other in the range 0 to 15. The current of the loop is fixed to a minimum value (typically 4 mA).

**Figure 7. Multidrop Connection**

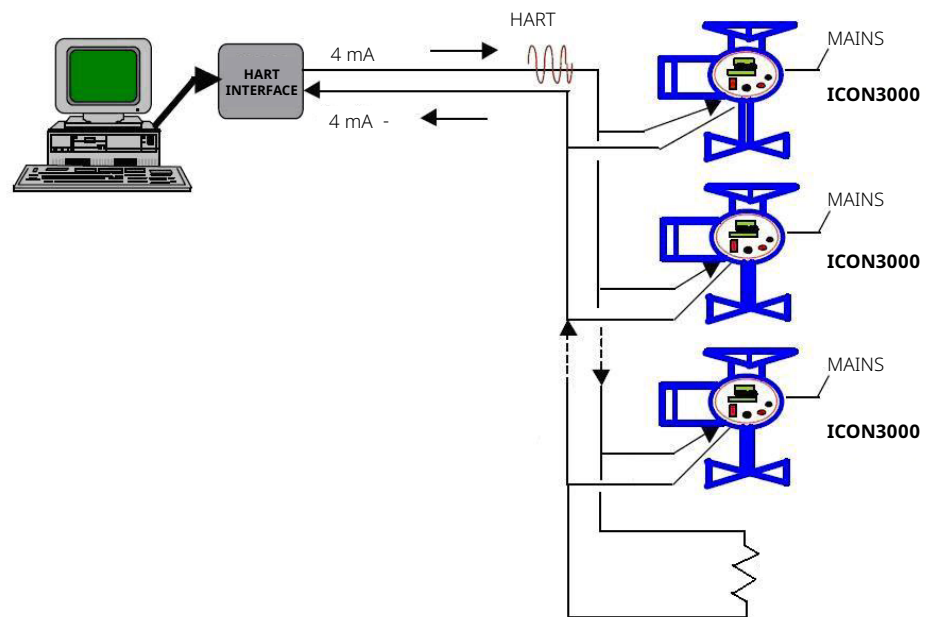

To work in Multidrop mode, the EleHRT-24 module needs to be configured by the local control panel of the actuator: "HART Relay" must be set to OPEN (see Section 11.1) and the 250 Ohm resistance must be placed between the terminals HART+ and HART- of the last actuator to close the 4 to 20mA current loop.

Alternatively, only in the last actuator of 4 to 20 mA current loop, the "HART Relay" can be set to CLOSE. In this case, it is not necessary to add the 250 Ohm resistance to close the 4 to 20 mA loop. The other actuators of the loop must have the "HART Relay" parameter configured to OPEN.

# Section 6: Wiring and Installation

In general, the installation practice for HART communicating devices is the same as conventional 4 to 20 mA instrumentation. Individually shielded twisted pair cable, either in single-pair or multi-pair varieties is the recommended wiring practice. Unshielded cables may be used for short distances if ambient noise and cross-talk will not affect communication. The minimum conductor size is 0.51 mm diameter (#24 AWG) for cable runs less than 1524 m / 5000 ft and 0.81 mm diameter (#20 AWG) for longer distances.

## 6.1 Cable Length

Most installations are well within the 3000 m / 10,000 ft theoretical limit for HART communication. However, the electrical characteristics of the cable (mostly capacitance) and the combination of connected devices can affect the maximum allowable cable length of a HART network. Table 1 shows the effect of cable capacitance and the number of network devices on cable length. The table is based on typical installations of HART devices in non-IS environments, i.e., no miscellaneous series impedance. Detailed information for determining the maximum cable length for any HART network configuration can be found in the HART Physical Layer Specifications.

**Table 1. Cable Length**

Number of Network Devices	65 pF/m	95 pF/m	160 pF/m	225 pF/m
1	2769 m	2000 m	1292 m	985 m
5	2462 m	1815 m	1138 m	892 m
10	2154 m	1600 m	1015 m	769 m
15	1846 m	1415 m	892 m	708 m

**NOTE:**

Cable Capacitance – pF/m      Cable Length – m

**Recommended Minimum Conductor Size (Diameter):**

- Below 1785 m / 5000 ft total length: #24 AWG (0.51 mm diameter).
- Above 1785 m (single pair) total length: #20 AWG (0.81 mm diameter).

## 6.2 Shielding and Grounding

The cable shield must be grounded at one point only. This is usually done in the control room or near to the source of the current loop. Ground connection may alternatively occur in a junction box or other suitable location in the field area. The cable shield is usually left open at the field device.

**Figure 8. Shielding and Grounding**

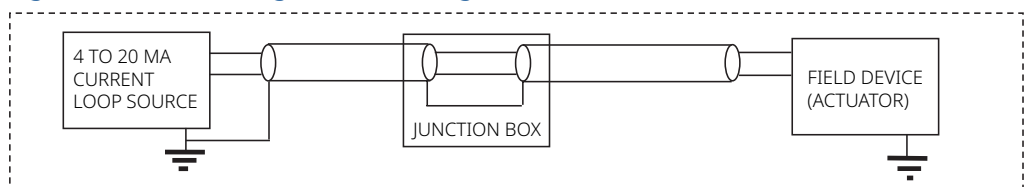

Other grounding modes can be used if the coupling and the EMI do not damage the HART digital signal. More information can be viewed on the HART FSK Physical Layer Specification.

# Section 7: HART Commands

The HART Command Set provides uniform and consistent communication for all field devices. The command set includes three classes: Universal, Common Practice and Device-Specific, refer to Table 2. Host applications may implement any of the necessary commands for a particular application.

- **UNIVERSAL**

All devices using the HART Protocol must recognize and support the universal commands. Universal commands provide access to information useful in normal operations (e.g., read primary variable and units).

- **COMMON PRACTICE**

Common Practice commands provide functions implemented by many, but not necessarily all HART communication devices.

- **DEVICE-SPECIFIC**

Device-Specific commands represent functions that are unique to each field device. These commands access setup and calibration information, as well as information about the construction of the device.

**Table 2. EleHRT-24 Commands**

Universal Commands	Common Practice Commands	Device Specific Commands
<ul style="list-style-type: none"> <li>• Read Unique Identifier</li> <li>• Read Primary Variable</li> <li>• Read Loop Current and Percent of Range</li> <li>• Read Dynamic Variables and WLoop Current</li> <li>• Write Polling Address</li> <li>• Read Loop Configuration</li> <li>• Read Dynamic Variable Classifications</li> <li>• Read Device Variables with Status</li> <li>• Read Unique Identifier Associated with Tag</li> <li>• Read Message</li> <li>• Read Tag, Descriptor, Date</li> <li>• Read Primary Variable Transducer Information</li> <li>• Read Device Information</li> <li>• Read Final Assembly Number</li> <li>• Write Message</li> <li>• Write Tag, Descriptor, Date</li> <li>• Write Final Assembly Number</li> <li>• Read Long Tag</li> <li>• Read Unique Identifier Associated with Long Tag</li> <li>• Write Long Tag</li> <li>• Reset Configuration Changed Flag</li> <li>• Read Additional Device Status</li> </ul>	<ul style="list-style-type: none"> <li>• Read Dynamic Variable Assignments</li> <li>• Write Dynamic Variable Assignments</li> <li>• Read Device Variable Information</li> <li>• Write Number of Response Preamble</li> <li>• Read Device Communications Statistics</li> <li>• Write Burst Period</li> <li>• Write Burst Trigger</li> <li>• Read Burst Mode Configuration</li> <li>• Write Burst Device Variables</li> <li>• Write Burst Mode Command Number</li> <li>• Burst Mode Control</li> </ul>	<ul style="list-style-type: none"> <li>• Read Array</li> <li>• Write Array</li> <li>• Read Param_E Parameters</li> <li>• Write Param_E Parameters</li> <li>• Read Param_BE Parameters</li> <li>• Write Param_BE Parameters</li> <li>• Read Param_F Parameters</li> <li>• Write Param_F Parameters</li> <li>• Read Param_D Parameters</li> <li>• Write Param_D Parameters</li> <li>• Read Param_U32 Parameters</li> <li>• Write Param_U32 Parameters</li> <li>• Read Param_S32 Parameters</li> <li>• Write Param_S32 Parameters</li> <li>• Write Param_Str8 Parameters</li> <li>• Read Param_Str8 Parameters</li> <li>• Write Param_Str4 Parameters</li> <li>• Read Param_Str4 Parameters</li> <li>• Read FST Torque Curve Data Header</li> <li>• Read FST Torque Curve</li> <li>• Read PST Curve Data Header</li> <li>• Read PST Curve Part 1</li> <li>• Read PST Curve Part 2</li> <li>• Read EFS Curve Data Header</li> <li>• Read EFS Curve Part 1</li> <li>• Read EFS Curve Part 2</li> <li>• Read Event Log Data Header</li> <li>• Read Event Log</li> <li>• Read Recorder Log Data Header</li> <li>• Read Recorder Log</li> <li>• Read T-Recorder Log Data Header</li> <li>• Read T-Recorder Log</li> <li>• Read Card Report</li> <li>• Write Card Report Read Alarms, Warnings and Connections Logs Data Header</li> <li>• Read Alarms Log</li> <li>• Read Warnings Log</li> <li>• Read Connections Log</li> <li>• Read Actuator Commands</li> <li>• Write Actuator Commands</li> <li>• Read Actuator Status</li> <li>• Read PST Status</li> </ul>

All slave response messages return two Command Status bytes in the first two bytes of the Data field. The first byte is multiplexed and contains either the Communication Status (most significant bit is set) or the Response Code (most significant bit is reset). The second byte of a slave response message always contains Field Device Status.

The Response Data Bytes are not returned if a communication or command error is reported in the Command Status Bytes.

The Communication Status is returned if a communication error is detected by the field device.

**Table 3. Communication Status Definition**

Bit Mask	Communication Status Definition
0x80	1 – This bit is always set to indicate a communication error
0x40	Vertical Parity Error – The parity of one or more of the bytes received by the device was not odd
0x20	Overrun Error – At least one byte of data in the receive buffer of the HART was overwritten before it was read
0x10	Framing Error – The Stop Bit of one or more bytes received by the device was not detected by the HART
0x08	Longitudinal Parity Error – The Longitudinal Parity calculated by the device did not match the Check Byte at the end of the message
0x04	Reserved – always 0
0x02	Buffer Overflow – The message was too long for the receive buffer of the device.
0x01	Reserved – always 0

If no communication errors are detected, the first byte in the Data Field contains the Response Code. The Response Code describes the result of the executed command.

The Response Code is encoded as a 7-bit enumeration (between 0 and 127).

There are 3 Classification Response Codes:

- Notification: The command sent by the Master is executed properly by the Slave.
- Warning: The command sent by the Master is executed with the deviation as described in the response.
- Error: The command sent by the Master was not properly completed and the Response Code indicates the reason.

See the appropriate Response Code Table for each command.

The second data byte in a Slave-to-Master frame is a bit field table that represent the current operating status of the slave.

**Table 4. Communication Status Definition**

Bit Mask	Communication Status Definition
0x80	Device Malfunction – The device detected a serious error or failure that compromises device operation
0x40	Configuration Changed – An operation was performed that changed the device's configuration
0x20	Cold Start – A power failure or Device Reset has occurred
0x10	More Status Available – More status information is available via command 48, Read Additional Device Status
0x08	Loop Current Fixed – The Loop Current is being held at a fixed value and is not responding to process variations
0x04	Loop Current Saturated – The Loop Current has reached its upper (or lower) endpoint limit and cannot increase (or decrease) any further
0x02	Non-Primary Variable Out of Limits – A Device Variable not mapped to PV is beyond its operating limits
0x01	Primary Variable Out of Limits – The PV is beyond its operating limit

**NOTES:**

1. Device Malfunction bit is set if a generic alarm or warning is active, maintenance operation is required, one or more device variables are not loaded by the logic card or Main Voltage alarm is active.
2. Configuration Changed bit is set if one or more parameters are modified by a HART command.
3. Cold Start bit is set after a power on or reset operation has occurred.
4. More Status Available bit is set if additional device status data bytes are changed.
5. Loop Current Fixed bit is set if Loop Current Mode is disabled.
6. Loop Current Saturated, Non-Primary Variable Out of Limits, Primary variable Out of Limits bits are not used. These bits are always set to 0.

# Section 8: HART Command Set

## 8.1 Universal Commands

**Table 5. Universal Command List**

Number	Command Description
0	Read Unique Identifier
1	Read Primary Variable
2	Read Loop Current and Percent of Range
3	Read Dynamic Variables and Loop Current
6	Write Polling Address
7	Read Loop Configuration
8	Read Dynamic Variable Classifications
9	Read Device Variables with Status
11	Read Unique Identifier Associated with Tag
12	Read Message
13	Read Tag, Descriptor, Date
14	Read Primary Variable Transducer Information
15	Read Device Information
16	Read Final Assembly Number
17	Write Message
18	Write Tag, Descriptor, Date
19	Write Final Assembly Number
20	Read Long Tag
21	Read Unique Identifier Associated with long Tag
22	Write Long Tag
38	Reset Configuration Changed Flag
48	Read Additional Device Status

### 8.1.1 Command #0: Read Unique Identifier

This command returns identity information about the field device including: Device Type, Revision Levels, and Device ID.

**Table 6. Request Data Bytes**

Byte	Format	Description
None	-	-

**Table 7. Response Data Bytes**

Byte	Format	Description
0	Unsigned-8	"254" – Fixed Value
1 to 2	Enum	Expanded Device Type Code (see Section 8.4, Table 251)
3	Unsigned-8	3 = Minimum number of preambles required for the request message from the Master to the Slave
4	Unsigned-8	7 = HART Protocol Major Revision
5	Unsigned-8	Device Revision
6	Unsigned-8	Software Revision
7	Unsigned-5	MSB (5 bits) – Hardware Revision
7	Enum	LSB (3 bits) – Physical Signaling Code (see Section 8.4, Table 258)
8	Bits	Flag Assignment (see Section 8.4, Table 259)
9 to 11	Unsigned-24	Device ID
12	Unsigned-8	Minimum Number of preambles to be sent with the response message from the Slave to the Master.
13	Unsigned-8	Maximum Number of Device Variables.
14 to 15	Unsigned-16	Configuration Change Counter
16	Bits	Extended Field Device Status (see Section 8.4, Table 261)
17 to 18	Enum	Manufacturer Identification Code (see Section 8.4, Table 256)
19 to 20	Enum	Private Label Distributor Code (see Section 8.4, Table 256)
21	Enum	Device Profile (see Section 8.4, Table 266)

**Table 8. Command-Specific Response Codes**

Code	Class	Description
0	Success	No Command-Specific Errors
1 to 127	-	Undefined

## 8.1.2 Command #1: Read Primary Variable

This command returns the Primary Variable value with its Unit Code. The Primary Variable (PV) is the percentage corresponding to the Loop Current signal.

**Table 9. Request Data Bytes**

Byte	Format	Description
None	-	-

**Table 10. Request Data Bytes**

Byte	Format	Description
0	Enum	Primary Variable Unit Codes (see Section 8.4, Table 252)
1 to 4	Float	Primary Variable

**Table 11. Command-Specific Response Codes**

Code	Class	Description
0	Success	No Command-Specific Errors
1 to 5	-	Undefined
6	Error	Device-Specific Command Error
7	-	Undefined
8	Warning	Update Failure
9 to 15	-	Undefined
16	Error	Access Restricted
1 to 127	-	Undefined

### 8.1.3 Command #2: Read Loop Current and Percent of Range

This command reads the Loop Current and its associated Percent of Range.

**Table 12. Request Data Bytes**

Byte	Format	Description
None	-	-

**Table 13. Response Data Bytes**

Byte	Format	Description
0 to 3	Float	Primary Variable Loop Current (units of mA)
4 to 7	Float	Primary Variable Percent of Range (units of percent)

**Table 14. Command-Specific Response Codes**

Code	Class	Description
0	Success	No Command-Specific Errors
1 to 5	-	Undefined
6	Error	Device-Specific Command Error
7	-	Undefined
8	Warning	Update Failure
9 to 15	-	Undefined
16	Error	Access Restricted
17 to 127	-	Undefined

### 8.1.4 Command #3: Read Dynamic Variables and Loop Current

This command reads the Loop Current and the four Dynamic Variables: the position request (PV – Primary Variable), the actuator position (SV – Secondary Variable), the output torque (TV – Tertiary Variable), the internal actuator temperature (QV – Quaternary Variable).

**Table 15. Request Data Bytes**

Byte	Format	Description
None	-	-

**Table 16. Response Data Bytes**

Byte	Format	Description
0 to 3	Float	Primary Variable Loop Current (units of mA)
4	Enum	Primary Variable Units Code (see Section 8.4, Table 252)
5 to 8	Float	Primary Variable
9	Enum	Secondary Variable Units Code (see Section 8.4, Table 252)
10 to 13	Float	Secondary Variable
14	Enum	Tertiary Variable Units Code (see Section 8.4, Table 252)
15 to 18	Float	Tertiary Variable
19	Enum	Quaternary Variable Units Code (see Section 8.4, Table 252)
20 to 23	Float	Quaternary Variable

**Table 17. Command-Specific Response Codes**

Code	Class	Description
0	Success	No Command-Specific Errors
1 to 5	-	Undefined
6	Error	Device-Specific Command Error
7	-	Undefined
8	Warning	Update Failure
9 to 15	-	Undefined
16	Error	Access Restricted
17 to 127	-	Undefined

## 8.1.5 Command #6: Write Polling Address

This command permits to write the Polling Address and the Loop Current mode to the field device.

**Table 18. Request Data Bytes**

Byte	Format	Description
0	Unsigned-8	Polling Address of Device
1	Enum	Loop Current Mode (see Section 8.4, Table 260)

**Table 19. Response Data Bytes**

Byte	Format	Description
0	Unsigned-8	Polling Address of Device
1	Enum	Loop Current Mode (see Section 8.4, Table 260)

**Table 20. Command-Specific Response Codes**

Code	Class	Description
0	Success	No Command-Specific Errors
1	-	Undefined
2	Error	Invalid Poll Address Selection
3 to 4	-	Undefined
5	Error	Too Few Data Bytes Received
6	Error	Device-Specific Command Error
7	Error	In Write Protect Mode
8 to 11	-	Undefined
12	Error	Invalid Mode Selection
13 to 15	-	Undefined
16	Error	Access Restricted
17 to 31	-	Undefined
32	Error	Busy
33 to 127	-	Undefined

## 8.1.6 Command #7: Read Loop Configuration

This command reads the Polling Address and the Loop Current mode.

**Table 21. Request Data Bytes**

Byte	Format	Description
None	-	-

**Table 22. Response Data Bytes**

Byte	Format	Description
0	Unsigned-8	Polling Address of Device
1	Enum	Loop Current Mode (see Section 8.4, Table 260)

**Table 23. Command-Specific Response Codes**

Code	Class	Description
0	Success	No Command-Specific Errors
1 to 15	-	Undefined
16	Error	Access Restricted
17 to 127	-	Undefined

## 8.1.7 Command #8: Read Dynamic Variable Classifications

This command reads the classification associated with the Dynamic Variables.

**Table 24. Request Data Bytes**

Byte	Format	Description
None	-	-

**Table 25. Response Data Bytes**

Byte	Format	Description
0	Enum	Primary Variable Classification (see Section 8.4, Table 263)
1	Enum	Secondary Variable Classification (see Section 8.4, Table 263)
2	Enum	Tertiary Variable Classification (see Section 8.4, Table 263)
3	Enum	Quaternary Variable Classification (see Section 8.4, Table 263)

**Table 26. Command-Specific Response Codes**

Code	Class	Description
0	Success	No Command-Specific Errors
1 to 15	-	Undefined
16	Error	Access Restricted
17 to 127	-	Undefined

## 8.1.8 Command #9: Read Device Variables with Status

This command allows a Master to request the value and status of up to 8 Device or Dynamic Variables.

If the Field Device receives 1, 2, 3, 4, 5, 6 or 7 Request Data Bytes, it returns only the corresponding number of Device Variables.

**Table 27. Read Device Variables**

Number of Device Variables Requested	Number of Request Data Bytes	Number of Response Data Bytes
1	1	13
2	2	21
3	3	29
4	4	37
5	5	45
6	6	53
7	7	61
8	8	69

**Table 28. Response Data Bytes**

Byte	Format	Description
0	Unsigned-8	Slot 0: Device Variable Code (see Section 9.1)
1	Unsigned-8	Slot 1: Device Variable Code (see Section 9.1)
2	Unsigned-8	Slot 2: Device Variable Code (see Section 9.1)
3	Unsigned-8	Slot 3: Device Variable Code (see Section 9.1)
4	Unsigned-8	Slot 4: Device Variable Code (see Section 9.1)
5	Unsigned-8	Slot 5: Device Variable Code (see Section 9.1)
6	Unsigned-8	Slot 6: Device Variable Code (see Section 9.1)
7	Unsigned-8	Slot 7: Device Variable Code (see Section 9.1)

**Table 29. Response Data Bytes**

Byte	Format	Description
0	Bits	Extended Field Device Status (see Section 8.4, Table 261)
1	Unsigned-8	Slot 0: Device Variable Code (see Section 9.1)
2	Enum	Slot 0: Device Variable Classification (see Section 8.4, Table 263)
3	Enum	Slot 0: Unit Code (see Section 8.4, Table 252)
4 to 7	Float	Slot 0: Device Variable Value
8	Bits	Slot 0: Device Variable Status (see Section 9.2)
9	Unsigned-8	Slot 1: Device Variable Code (see Section 9.1)
10	Enum	Slot 1: Device Variable Classification (see Section 8.4, Table 263)
11	Enum	Slot 1: Units Code (see Section 8.4, Table 252)
12 to 15	Float	Slot 1: Device Variable Value
16	Bits	Slot 1: Device Variable Status (see Section 9.2)
17	Unsigned-8	Slot 2: Device Variable Code (see Section 9.1)
18	Enum	Slot 2: Device Variable Classification (see Section 8.4, Table 263)
19	Enum	Slot 2: Units Code (see Section 8.4, Table 252)
20 to 23	Float	Slot 2: Device Variable Value
24	Bits	Slot 2: Device Variable Status (see Section 9.2)
25	Unsigned-8	Slot 3: Device Variable Code (see Section 9.1)
26	Enum	Slot 3: Device Variable Classification (see Section 8.4, Table 263)
27	Enum	Slot 3: Units Code (see Section 8.4, Table 252)
28 to 31	Float	Slot 3: Device Variable Value
32	Bits	Slot 3: Device Variable Status (see Section 9.2)

**Table 30. Response Data Bytes (Continued)**

Byte	Format	Description
33	Unsigned-8	Slot 4: Device Variable Code (see Section 9.1)
34	Enum	Slot 4: Device Variable Classification (see Section 8.4, Table 263)
35	Enum	Slot 4: Units Code (see Section 8.4, Table 252)
36 to 39	Float	Slot 4: Device Variable Value
40	Bits	Slot 4: Device Variable Status (see Section 9.2)
41	Unsigned-8	Slot 5: Device Variable Code (see Section 9.1)
42	Enum	Slot 5: Device Variable Classification (see Section 8.4, Table 263)
43	Enum	Slot 5: Units Code (see Section 8.4, Table 252)
44 to 47	Float	Slot 5: Device Variable Value
48	Bits	Slot 5: Device Variable Status (see Section 9.2)
49	Unsigned-8	Slot 6: Device Variable Code (see Section 9.1)
50	Enum	Slot 6: Device Variable Classification (see Section 8.4, Table 263)
51	Enum	Slot 6: Units Code (see Section 8.4, Table 252)
52 to 55	Float	Slot 6: Device Variable Value
56	Bits	Slot 6: Device Variable Status (see Section 9.2)
57	Unsigned-8	Slot 7: Device Variable Code (see Section 9.1)
58	Enum	Slot 7: Device Variable Classification (see Section 8.4, Table 263)
59	Enum	Slot 7: Units Code (see Section 8.4, Table 252)
60 to 63	Float	Slot 7: Device Variable Value
64	Bits	Slot 7: Device Variable Status (see Section 9.2)
65 to 68	Time	Slot 0: Data Time Stamp

**Table 31. Command-Specific Response Codes**

Code	Class	Description
0	Success	No Command-Specific Errors
1	-	Undefined
2	Error	Invalid Selection
3 to 4	-	Undefined
5	Error	Too Few Data Bytes Received
6	Error	Device-Specific Command Error
7	-	Undefined
8	Warning	Update Failure
9 to 13	-	Undefined
14	Warning	Dynamic Variables Returned for Device Variables
15	-	Undefined
16	Error	Access Restricted
17 to 29	-	Undefined
30	Warning	Command Response Truncated
31 to 127	-	Undefined

## 8.1.9 Command #11: Read Unique Identifier Associated with Tag

This command returns identity information about the field device including: Device Type, Revision levels and Device ID.

**Table 32. Request Data Bytes**

Byte	Format	Description
0 to 5	Packed	Tag

**Table 33. Response Data Bytes**

Byte	Format	Description
0	Unsigned-8	"254" – Fixed Value
1 to 2	Enum	Expanded Device Type Code (see Section 8.4, Table 251)
3	Unsigned-8	3 = Minimum number of preambles required for the request message from the Master to the Slave
4	Unsigned-8	7 = HART Protocol Major Revision
5	Unsigned-8	Device Revision
6	Unsigned-8	Software Revision
7	Unsigned-5	MSB (5 bits) – Hardware Revision
7	Enum	LSB (3 bits) – Physical Signaling Code (see Section 8.4, Table 258)
8	Bits	Flag Assignment (see Section 8.4, Table 259)
9 to 11	Unsigned-24	Device ID
12	Unsigned-8	Minimum Number of preambles to be sent with the response message from the Slave to the Master
13	Unsigned-8	Maximum Number of Device Variables
14 to 15	Unsigned-16	Configuration Change Counter
16	Bits	Extended Field Device Status (see Section 8.4, Table 261)
17 to 18	Enum	Manufacturer Identification Code (see Section 8.4, Table 256)
19 to 20	Enum	Private Label Distributor Code (see Section 8.4, Table 256)
21	Enum	Device Profile (see Section 8.4, Table 267)

**Table 34. Command-Specific Response Codes**

Code	Class	Description
0	Success	No Command-Specific Errors
1 to 127	-	Undefined

## 8.1.10 Command #12: Read Message

This command reads the Message contained within the field device.

**Table 35. Request Data Bytes**

Byte	Format	Description
None	-	-

**Table 36. Response Data Bytes**

Byte	Format	Description
0 to 23	Packed	Message

**Table 37. Command-Specific Response Codes**

Code	Class	Description
0	Success	No Command-Specific Errors
1 to 15	-	Undefined
16	Error	Access Restricted
17 to 31	-	Undefined
32	Error	Busy
33 to 127	-	Undefined

## 8.1.11 Command #13: Read Tag, Descriptor, Date

This command reads the Tag, Descriptor and Date contained within the field device. Only Tag is read by this command. Tag and Long Tag are completely separate data items.

**Table 38. Request Data Bytes**

Byte	Format	Description
None	-	-

**Table 39. Response Data Bytes**

Byte	Format	Description
0 to 5	Packed	Tag
6 to 17	Packed	Descriptor
18 to 20	Date	Date Code

**Table 40. Command-Specific Response Codes**

Code	Class	Description
0	Success	No Command-Specific Errors
1 to 15	-	Undefined
16	Error	Access Restricted
17 to 31	-	Undefined
32	Error	Busy
33 to 127	-	Undefined

## 8.1.12 Command #14: Read Primary Variable Transducer Information

This command reads the Transducer Serial Number, Limits/Minimum Span Units Code, Upper Transducer Limit, Lower Transducer Limit and Minimum Span for the Primary Variable Transducer.

**Table 41. Request Data Bytes**

Byte	Format	Description
None	-	-

**Table 42. Response Data Bytes**

Byte	Format	Description
0 to 2	Unsigned-24	Transducer Serial Number
3	Enum	Transducer Limits and Minimum Span units Code (see Section 8.4, Table 252)
4 to 7	Float	Upper Transducer Limit
8 to 11	Float	Lower Transducer Limit
12 to 15	Float	Minimum Span

**Table 43. Command-Specific Response Codes**

Code	Class	Description
0	Success	No Command-Specific Errors
1 to 15	-	Undefined
16	Error	Access Restricted
17 to 31	-	Undefined
32	Error	Busy
33 to 127	-	Undefined

## 8.1.13 Command #15: Read Device Information

This command reads the alarm selection code, transfer function code, range values units code, upper range value, Primary Variable lower range value, damping value and write protect code.

**Table 44. Request Data Bytes**

Byte	Format	Description
None	-	-

**Table 45. Response Data Bytes**

Byte	Format	Description
0	Enum	PV Alarm Selection Code (see Section 8.4, Table 254)
1	Enum	PV Transfer Function Code (see Section 8.4, Table 253)
2	Enum	PV Upper and Lower Range Values Units Code (see Section 8.4, Table 252)
3 to 6	Float	PV Upper Range Value
7 to 10	Float	PV Lower Range Value
11 to 14	-	PV Damping Value (units of seconds)
15	Enum	Write Protect Code (see Section 8.4, Table 255)
16	Enum	Reserved. "250"
17	Bits	PV Analog Channel Flags (see Section 8.4, Table 264)

**Table 46. Command-Specific Response Codes**

Code	Class	Description
0	Success	No Command-Specific Errors
1 to 15	-	Undefined
16	Error	Access Restricted
17 to 31	-	Undefined
32	Error	Busy
33 to 127	-	Undefined

## 8.1.14 Command #16: Read Final Assembly Number

This command reads the final assembly number associated within the field device. The Final Assembly Number is used for identifying the materials and electronics that comprise the field device.

**Table 47. Request Data Bytes**

Byte	Format	Description
None	-	-

**Table 48. Response Data Bytes**

Byte	Format	Description
0 to 2	Unsigned-24	Final Assembly Number

**Table 49. Command-Specific Response Codes**

Code	Class	Description
0	Success	No Command-Specific Errors
1 to 15	-	Undefined
16	Error	Access Restricted
17 to 31	-	Undefined
32	Error	Busy
33 to 127	-	Undefined

## 8.1.15 Command #17: Write Message

This command permits to write the Message into the field device.

**Table 50. Request Data Bytes**

Byte	Format	Description
0 to 23	Packed	A Message string used by the Master for record keeping

**Table 51. Response Data Bytes**

Byte	Format	Description
0 to 23	Packed	Message string

**Table 52. Command-Specific Response Codes**

Code	Class	Description
0	Success	No Command-Specific Errors
1 to 4	-	Undefined
5	Error	Too Few Data Bytes Received
6	Error	Device-Specific Command Error
7	Error	In Write Protect Mode
8 to 15	-	Undefined
16	Error	Access Restricted
17 to 31	-	Undefined
32	Error	Busy
33 to 127	-	Undefined

## 8.1.16 Command #18: Write Tag, Descriptor, Date

This command permits to write the Tag, Descriptor and Date into the field device. Only the Tag is written here. The Tag and Long Tag are completely separate data items.

**Table 53. Request Data Bytes**

Byte	Format	Description
0 to 5	Packed	Tag
6 to 17	Packed	Descriptor used by the Master for record keeping
18 to 20	Date	A Date Code used by the Master for record keeping

**Table 54. Response Data Bytes**

Byte	Format	Description
0 to 5	Packed	Tag
6 to 17	Packed	Descriptor
18 to 20	Date	Date Code

**Table 55. Command-Specific Response Codes**

Code	Class	Description
0	Success	No Command-Specific Errors
1 to 4	-	Undefined
5	Error	Too Few Data Bytes Received
6	Error	Device-Specific Command Error
7	Error	In Write Protect Mode
8	-	Undefined
9	Error	Invalid Date Code Detected
10 to 15	-	Undefined
16	Error	Access Restricted
17 to 31	-	Undefined
32	Error	Busy
33 to 127	-	Undefined

## 8.1.17 Command #19: Write Final Assembly Number

This command permits to write the Final Assembly Number into the field device.

**Table 56. Request Data Bytes**

Byte	Format	Description
0 to 2	Unsigned-24	Final Assembly Number

**Table 57. Response Data Bytes**

Byte	Format	Description
0 to 2	Unsigned-24	Final Assembly Number

**Table 58. Command-Specific Response Codes**

Code	Class	Description
0	Success	No Command-Specific Errors
1 to 4	-	Undefined
5	Error	Too Few Data Bytes Received
6	Error	Device-Specific Command Error
7	Error	In Write Protect Mode
8 to 15	-	Undefined
16	Error	Access Restricted
17 to 31	-	Undefined
32	Error	Busy
33 to 127	-	Undefined

## 8.1.18 Command #20: Read Long Tag

This command reads the Long Tag. Only the Long Tag is read here. The Tag and Long Tag are completely separate data items.

**Table 59. Request Data Bytes**

Byte	Format	Description
None	-	-

**Table 60. Response Data Bytes**

Byte	Format	Description
0 to 31	Latin-1	Long Tag

**Table 61. Command-Specific Response Codes**

Code	Class	Description
0	Success	No Command-Specific Errors
1 to 15	-	Undefined
16	Error	Access Restricted
17 to 31	-	Undefined
32	Error	Busy
33 to 127	-	Undefined

## 8.1.19 Command #21: Read Unique Identifier Associated with Long Tag

This command returns identity information about the field device including: the Device Type, revision levels and Device ID.

**Table 62. Request Data Bytes**

Byte	Format	Description
0 to 31	Latin-1	Long Tag

**Table 63. Response Data Bytes**

Byte	Format	Description
0	Unsigned-8	"254" – Fixed Value
1 to 2	Enum	Expanded Device Type Code (see Section 8.4, Table 251)
3	Unsigned-8	3 = Minimum number of preambles required for the request message from the Master to the Slave
4	Unsigned-8	7 = HART Protocol Major Revision
5	Unsigned-8	Device Revision
6	Unsigned-8	Software Revision
7	Unsigned-5	MSB (5 bits) – Hardware Revision
7	Enum	LSB (3 bits) – Physical Signaling Code (see Section 8.4, Table 258)
8	Bits	Flag Assignment (see Section 8.4, Table 259)
9 to 11	Unsigned-24	Device ID
12	Unsigned-8	Minimum Number of preambles to be sent with the response message from the Slave to the Master
13	Unsigned-8	Maximum Number of Device Variables
14 to 15	Unsigned-16	Configuration Change Counter
16	Bits	Extended Field Device Status (see Section 8.4, Table 261)
17 to 18	Enum	Manufacturer Identification Code (see Section 8.4, Table 256)
19 to 20	Enum	Private Label Distributor Code (see Section 8.4, Table 256)
21	Enum	Device Profile (see Section 8.4, Table 266)

**Table 64. Command-Specific Response Codes**

Code	Class	Description
0	Success	No Command-Specific Errors
1 to 127	-	Undefined

## 8.1.20 Command #22: Write Long Tag

This command allows a Master to write the Long Tag into the field device. Only the Long Tag is written here. The Tag and Long Tag are completely separate data items.

**Table 65. Request Data Bytes**

Byte	Format	Description
0 to 31	Latin-1	Long Tag

**Table 66. Response Data Bytes**

Byte	Format	Description
0 to 31	Latin-1	Long Tag

**Table 67. Command-Specific Response Codes**

Code	Class	Description
0	Success	No Command-Specific Errors
1 to 4	-	Undefined
5	Error	Too Few Data Bytes Received
6	Error	Device-Specific Command Error
7	Error	In Write Protect Mode
8 to 15	-	Undefined
16	Error	Access Restricted
17 to 31	-	Undefined
32	Error	Busy
33	Error	Delayed Response Initiated
34	Error	Delayed Response Running
35	Error	Delayed Response Dead
36	Error	Delayed Response Conflict
37 to 127	-	Undefined

## 8.1.21 Command #38: Reset Configuration Changed Flag

This command allows a Master to reset the Configuration Change Flag into the field device.

**Table 68. Request Data Bytes**

Byte	Format	Description
0 to 1	Unsigned-16	Configuration Change Counter

**Table 69. Response Data Bytes**

Byte	Format	Description
0 to 1	Unsigned-16	Configuration Change Counter

**Table 70. Command-Specific Response Codes**

Code	Class	Description
0	Success	No Command-Specific Errors
1 to 5	-	Undefined
6	Error	Device-Specific Command Error
7	Error	In Write Protect Mode
8	-	Undefined
9	Error	Configuration Change Counter Mismatch
10 to 15	-	Undefined
16	Error	Access Restricted
17 to 127	-	Undefined

## 8.1.22 Command #48: Read Additional Device Status

This command returns the device status information, device-specific status information, Extended Device Status, Device Operating Mode and Standardized Status.

**Table 71. Request Data Bytes**

Byte	Format	Description
0 to 5	Bits or Enum	Device-Specific Status
6	Bits	Extended Device Status
7	Bits	Device Operating Mode
8	Bits	Standardized Status 0
9	Bits	Standardized Status 1
10	Bits	Analog Channel Saturated
11	Bits	Standardized Status 2
12	Bits	Standardized Status 3
13	Bits	Analog Channel Fixed
14 to 15	Bits	Device-Specific Status

**NOTE:**

See table on the next page for details.

**Table 72. Response Data Bytes**

Byte	Format	Description
0 to 5	Bits or Enum	Device-Specific Status
6	Bits	Extended Device Status
7	Bits	Device Operating Mode
8	Bits	Standardized Status 0
9	Bits	Standardized Status 1
10	Bits	Analog Channel Saturated
11	Bits	Standardized Status 2
12	Bits	Standardized Status 3
13	Bits	Analog Channel Fixed
14 to 15	Bits	Device-Specific Status

**NOTE:**

See table on the next page for details.

**Table 73. Command-Specific Response Codes**

Code	Class	Description
0	Success	No Command-Specific Errors
1 to 5	-	Undefined
6	Error	Device-Specific Command Error
7	-	Undefined
8	Warning	Update in Progress
9 to 15	-	Undefined
16	Error	Access Restricted
17 to 127	-	Undefined

**Table 74. Request and Response Data Fields of EleHRT-24**

Byte	Bit	Meaning	Set to 1 if	Class	Device Status Bits Set
0	0	Motor Thermostat	Motor Thermostat Alarm is active	Error	4, 7
	1	Hi-Hi Torque in Opening Alarm	Hi-Hi Torque in Opening Alarm is active	Error	4, 7
	2	Hi-Hi Torque in Closing Alarm	Hi-Hi Torque in Closing Alarm is active	Error	4, 7
	3	Hi-Hi Temperature Alarm	Hi-Hi Temperature Alarm is active	Error	4, 7
	4	Position Sensor Alarm	Position Sensor Alarm is active	Error	4, 7
	5	Speed Sensor Alarm	Speed Sensor Alarm is active	Error	4, 7
	6	Main Voltage Alarm	Main Voltage Alarm is active	Error	4, 7
	7	K1 Contactor Alarm	K1 Contactor Alarm is active	Error	4, 7
1	0	K2 Contactor Alarm	K2 Contactor Alarm is active	Error	4, 7
	1	Configuration Alarm	Configuration Alarm is active	Error	4, 7
	2	Hardware Alarm	At least one of the Hardware Alarms is active	Error	4, 7
	3	Low Battery Alarm	Low Battery Alarm is active	Error	4, 7
	4	Lost Phase Alarm	Lost Phase Alarm is active	Error	4, 7
	5	Request Signal Alarm	Request Signal Alarm is active	Error	4, 7
	6	Manual Operation (Handwheel)	Manual Operation (Handwheel) Alarm is active	Warning	4
	7	Jammed in Closing Alarm	Jammed in Closing Alarm is active	Error	4, 7
2	0	Jammed in Opening Alarm	Jammed in Opening Alarm is active	Error	4, 7
	1	Direction Test Fail Alarm	Direction Test Alarm is active	Error	4, 7
	2	Mid-Travel in Opening Alarm	Mid-Travel in Opening Alarm is active	Error	4, 7
	3	Mid-Travel in Closing Alarm	Mid-Travel in Closing Alarm is active	Error	4, 7
	4	Not Used	Not Used, Reserved	Error	4, 7
	5	Not Used	Not Used, Reserved	Error	4, 7
	6	Not Used	Not Used, Reserved	Error	4, 7
	7	Not Used	Not Used, Reserved	Error	4, 7
3	0	Not Used	Not Used, Reserved	Error	4, 7
	1	Not Used	Not Used, Reserved	Error	4, 7
	2	Not Used	Not Used, Reserved	Error	4, 7
	3	Not Used	Not Used, Reserved	Error	4, 7
	4	Not Used	Not Used, Reserved	Error	4, 7
	5	Hardware Alarm 1	Hardware Alarm 1 is active	Error	4, 7
	6	Hardware Alarm 2	Hardware Alarm 2 is active	Error	4, 7
	7	Hardware Alarm 3	Hardware Alarm 3 is active	Error	4, 7
4	0	Hardware Alarm 4	Hardware Alarm 4 is active	Error	4, 7
	1	Hardware Alarm 5	Hardware Alarm 5 is active	Error	4, 7
	2	Hardware Alarm 6	Hardware Alarm 6 is active	Error	4, 7
	3	Hardware Alarm 7	Hardware Alarm 7 is active	Error	4, 7
	4	Hardware Alarm 8	Hardware Alarm 8 is active	Error	4, 7
	5	Hardware Alarm 9	Hardware Alarm 9 is active	Error	4, 7
	6	Hardware Alarm 10	Hardware Alarm 10 is active	Error	4, 7
	7	Hardware Alarm 11	Hardware Alarm 11 is active	Error	4, 7
5	0	Hardware Alarm 12	Hardware Alarm 12 is active	Error	4, 7
	1	Hardware Alarm 13	Hardware Alarm 13 is active	Error	4, 7
	2	EFS Mid-Travel	EFS Mid-Travel Alarm is active	Error	4, 7
	3	Not Used	Not Used, Reserved	-	-
	4	Not Used	Not Used, Reserved	-	-
	5	Not Used	Not Used, Reserved	-	-
	6	Not Used	Not Used, Reserved	-	-
	7	Not Used	Not Used, Reserved	-	-

**Table 75. Request and Response Data Fields of EleHRT-24 (Continued)**

Byte	Bit	Meaning	Set to 1 if	Class	Device Status Bits Set
6	0	Maintenance Required	The date of the next maintenance operation is reached	Warning	4, 7
	1	Device Variable Alert	One or more variable values is not correctly loaded by the device	Warning	4
	2	Not Used	Not Used, Reserved	-	-
	3	Not Used	Not Used, Reserved	-	-
	4	Not Used	Not Used, Reserved	-	-
	5	Not Used	Not Used, Reserved	-	-
	6	Not Used	Not Used, Reserved	-	-
7	Not Used	Not Used, Reserved	-	-	
7	-	Not Used	Not Used, Reserved	-	-
8	0	Not Used	Not Used, Reserved	-	-
	1	Not Used	Not Used, Reserved	-	-
	2	Not Used	Not Used, Reserved	-	-
	3	Not Used	Not Used, Reserved	-	-
	4	Not Used	Not Used, Reserved	-	-
	5	Not Used	Not Used, Reserved	-	-
	6	Electronic Defeat	Main Voltage Alarm is active	Error	4, 7
7	Not Used	Not Used, Reserved	-	-	
9	-	Not Used	Not Used, Reserved	-	-
10	-	Not Used	Not Used, Reserved	-	-
11	-	Not Used	Not Used, Reserved	-	-
12	-	Not Used	Not Used, Reserved	-	-
13	-	Not Used	Not Used, Reserved	-	-
14	0	Generic Warning	At least one warning is active	Warning	4
	1	Generic Alarm	At least one alarm is active	Error	4, 7
	2	Remote Control Not Available	The actuator cannot be remotely controlled. The bit is set to 1 when the Monitor relay is set to 0.	Warning	4
	3	Hi Torque in Opening	Hi Torque in Opening warning is active	Warning	4
	4	Hi Torque in Closing	Hi Torque in Closing warning is active	Warning	4
	5	Hi Temperature	Hi Temperature warning is active	Warning	4
	6	Main Voltage	Main Voltage warning is active	Warning	4
7	Contactors Cycles	Contactors Cycles warning is active	Warning	4	
15	0	Motor Current	Motor Current warning is active	Warning	4
	1	Wrong Stroke Limits	Wrong Stroke Limits warning is active	Warning	4
	2	Bus Fail	Bus Fail warning is active	Warning	4
	3	PST Error - Over Travel	PST OV-TR warning is active	Warning	4
	4	PST Error - Max T1 (T-PST)	PST T1 warning is active	Warning	4
	5	PST Error - Max T2 (T-RET)	PST T2 warning is active	Warning	4
	6	PST Error - PST Failed	At least two of the following PST errors occurred: Over Travel, Max T1, Max T2	Warning	4
7	Local Configuration	Local Configuration is active	Warning	4	

## 8.2 Common Practice Commands

The following common practice commands are implemented:

**Table 76. Common Practice Commands**

No.	Command Description
50	Read Dynamic Variable Assignments
51	Write Dynamic Variable Assignments
54	Read Device Variable Information
59	Write Number of Response Preamble
95	Read Device Communication Statistics
103	Write Burst Period
104	Write Burst Trigger
105	Read Burst Mode Configuration
107	Write Burst Device Variables
108	Write Burst Mode Command Number
109	Burst Mode Control

### 8.2.1 Command #50: Read Dynamic Variable Assignments

Responds with the Device Variable Numbers that are assigned to the Primary, Secondary, Tertiary and Quaternary Variables.

**Table 77. Request Data Bytes**

Byte	Format	Description
None	-	-

**Table 78. Response Data Bytes**

Byte	Format	Description
0	Unsigned Int-8	Device Variable assigned to Primary Variable
1	Unsigned Int-8	Device Variable assigned to Secondary Variable
2	Unsigned Int-8	Device Variable assigned to Tertiary Variable
3	Unsigned Int-8	Device Variable assigned to Quaternary Variable

**Table 79. Command-Specific Response Codes**

Code	Class	Description
0	Success	No Command-Specific Errors
1 to 5	-	Undefined
6	Error	Device-Specific Command Error
7 to 15	-	Undefined
16	Error	Access Restricted
17 to 127	-	Undefined

See Command #51 Write Dynamic Variable Assignments for available Device Variable Codes.

## 8.2.2 Command #51: Write Dynamic Variable Assignments

Assigns Device Variables to the Primary, Secondary, Tertiary and Quaternary Variables.

**Table 80. Request Data Bytes**

Byte	Format	Description
0	Unsigned Int-8	Device Variable assigned to Primary Variable
1	Unsigned Int-8	Device Variable assigned to Secondary Variable
2	Unsigned Int-8	Device Variable assigned to Tertiary Variable
3	Unsigned Int-8	Device Variable assigned to Quaternary Variable

**Table 81. Response Data Bytes**

Byte	Format	Description
0	Unsigned Int-8	Device Variable assigned to Primary Variable
1	Unsigned Int-8	Device Variable assigned to Secondary Variable
2	Unsigned Int-8	Device Variable assigned to Tertiary Variable
3	Unsigned Int-8	Device Variable assigned to Quaternary Variable

**Table 82. Command-Specific Response Codes**

Code	Class	Description
0	Success	No Command-Specific Errors
1	-	Undefined
2	Error	Invalid Selection
3 to 4	-	Undefined
5	Error	Too Few Data Bytes Received
6	Error	Device-Specific Command Error
7	Error	In Write Protect Mode
8 to 15	-	Undefined
16	Error	Access Restricted
17 to 31	-	Undefined
32	Error	Busy
33 to 127	-	Undefined

**PV Codes Available:**

Device Variable 0: Analog Position Request

**SV, TV, QV Codes Available:**

SV, TV, QV Codes Available:

Device Variable 0: Analog Position Request (default PV)

Device Variable 1: Actuator Position (default SV)

Device Variable 2: Torque (default TV)

Device Variable 3: Temperature (default QV)

Device Variable 4: Motor Speed

Device Variable 5: Main Voltage

Device Variable 6: Current

Device Variable 7: Motor Temperature

Device Variable 8: Terminal Board Temperature

Device Variable 9: Position Request (used by Logic Card)

Device Variable 10: Auxiliary Analog Input mA

Device Variable 11: Auxiliary Analog Input bit

Device Variable 12: Analog Output mA

Device Variable 13: Analog Output bit

Device Variable 14: Local Mode

Device Variable 15: Off Mode

Device Variable 16: Remote Mode

Device Variable 17: Stall Alarm

Device Variable 18: Device Alarm Active

Device Variable 19: Actuator Ready

Device Variable 20: Open Limit

Device Variable 21: Close Limit

Device Variable 22: Opening

Device Variable 23: Closing

Device Variable 24: Stopped

## 8.2.3 Command #54: Read Device Variable Information

This command reads the Transducer Serial Number, the Limits, Damping Value and Minimum Span of the selected Device Variable along with the corresponding engineering units.

**Table 83. Request Data Bytes**

Byte	Format	Description
0	Unsigned-8	Device Variable Code (see Section 9.1)

**Table 84. Response Data Bytes**

Byte	Format	Description
0	Unsigned-8	Device Variable Code (see Section 9.1)
1 to 3	Unsigned-24	Device Variable Transducer Serial Number
4	Enum	Device Variable Limits/Minimum Span Units Code (see Section 8.4, Table 252)
5 to 8	Float	Device Variable Upper Transducer Limit
9 to 12	Float	Device Variable Lower Transducer Limit
13 to 16	Float	Device Variable Damping Value
17 to 20	Float	Device Variable Minimum Span
21	Enum	Device Variable Classification (see Section 8.4, Table 263)
22	Enum	Device Variable Family (see Section 8.4, Table 262)
23 to 26	Time	Update Time Period

**Table 85. Command-Specific Response Codes**

Code	Class	Description
0	Success	No Command-Specific Errors
1	-	Undefined
2	Error	Invalid Selection
3 to 4	-	Undefined
5	Error	Too Few Data Bytes Received
6	Error	Device-Specific Command Error
7 to 15	-	Undefined
16	Error	Access Restricted
17 to 31	-	Undefined
32	Error	Busy
33 to 127	-	Undefined

## 8.2.4 Command #59: Write Number of Response Preambles

This command sets the number of asynchronous 0xFF preambles bytes to be sent by a device before the start of a response message. This value may be set to no smaller than 5 and no greater than 20.

**Table 86. Request Data Bytes**

Byte	Format	Description
0	Unsigned-8	Number of preambles to be sent with the response message from the Slave to the Master

**Table 87. Response Data Bytes**

Byte	Format	Description
0	Unsigned-8	Number of preambles to be sent with the response message from the Slave to the Master

**Table 88. Command-Specific Response Codes**

Code	Class	Description
0	Success	No Command-Specific Errors
1 to 2	-	Undefined
3	Error	Passed Parameter Too Large
4	Error	Passed Parameter Too Small
5	Error	Too Few Data Bytes Received
6	Error	Device-Specific Command Error
7	Error	In Write Protect Mode
8	Warning	Set To Nearest Possible Value
9 to 15	-	Undefined
16	Error	Access Restricted
17 to 31	-	Undefined
32	Error	Busy
33 to 127	-	Undefined

## 8.2.5 Command #95: Read Device Communication Statistics

This command returns the field device communication statistics: the number of STX messages received by the device, the number of ACK messages sent by the device and the number of BACK sent by the device.

**Table 89. Request Data Bytes**

Byte	Format	Description
None	-	-

**Table 90. Response Data Bytes**

Byte	Format	Description
0 to 1	Unsigned-16	Count of STX messages received by this device
2 to 3	Unsigned-16	Count of ACK messages sent from this device
4 to 5	Unsigned-16	Count of BACK messages sent from this device

**Table 91. Command-Specific Response Codes**

Code	Class	Description
0	Success	No Command-Specific Errors
1 to 5	-	Undefined
6	Error	Device-Specific Command Error
7 to 127	-	Undefined

## 8.2.6 Command #103: Write Burst Period

This command selects the minimum and maximum update period of a burst message. The minimum time must be less than or equal to the maximum time. The update time shall be selected as specified in Table 97 .

**Table 92. Burst Period**

< 0.5 s Not Allowed	8 s
0.5 s (default)	16 s
1 s	32 s
2 s	60 to 3600 s (any value)
4 s	> 3600 s Not Allowed

The device corrects settings differing from these values and indicates "Update Times Adjusted" in its response message.

**Table 93. Request Data Bytes**

Byte	Format	Description
0	Unsigned-8	Burst Message
1 to 4	Time	Update Period in 1 to 32 of a millisecond.
5 to 8	Time	Maximum Update Period in 1/32 of a millisecond.

**Table 94. Response Data Bytes**

Byte	Format	Description
0	Unsigned-8	Burst Message
1 to 4	Time	Update Period in 1 to 32 of a millisecond.
5 to 8	Time	Maximum Update Period in 1/32 of a millisecond.

**Table 95. Command-Specific Response Codes**

Code	Class	Description
0	Success	No Command-Specific Errors
1 to 4	-	Undefined
5	Error	Too Few Data Bytes Received
6	Error	Device-Specific Command Error
7	Error	In Write Protect Mode
8	Warning	Update Times Adjusted
9	Error	Invalid Burst Message
10 to 15	-	Undefined
16	Error	Access Restricted
17 to 31	-	Undefined
32	Error	Busy (A Delayed Response could not be initiated.)
33	Error	Delayed Response Initiated
34	Error	Delayed Response Running
35	Error	Delayed Response Dead
36	Error	Delayed Response Conflict
37 to 127	-	Undefined

## 8.2.7 Command #104: Write Burst Trigger

This command configures the trigger that forces publishing of the Burst Message. Four trigger modes are supported: Continuous (default), Windowed, Rising and Falling.

**Continuous Mode:** The burst message is sent when the update period is exceeded.

**Windowed Mode:** The trigger value must be a positive number and is the symmetric window around the last communicated value. The burst message being published after the window was exceeded.

**Rising Mode:** The burst message is published when the source value exceeds the threshold established by the trigger value.

**Falling Mode:** The burst message is published when the source value falls below the trigger value.

In all cases, the burst message is triggered when the maximum update time is Command 103 is exceeded.

**Table 96. Burst Message Trigger Source**

Command	Trigger Source Value
1	PV (Position Request)
2	Loop Current Percent Range
3	PV (Position Request)
9	Device Variable in Slot 0

**Table 97. Request Data Bytes**

Byte	Format	Description
0	Unsigned-8	Burst Message
1	Enum	Burst Trigger Mode Selection Code (see Section 8.4, Table 265)
2	Enum	Device Variable Classification for Trigger Level (see Section 8.4, Table 263)
3	Enum	Units Code (see Section 8.4, Table 252)
4 to 7	Float	Trigger Level

**Table 98. Response Data Bytes**

Byte	Format	Description
0	Unsigned-8	Burst Message
1	Enum	Burst Trigger Mode Selection Code (see Section 8.4, Table 264)
2	Enum	Device Variable Classification for Trigger Level (see Section 8.4, Table 262)
3	Enum	Units Code (see Section 8.4, Table 252)
4 to 7	Float	Trigger Level

**Table 99. Command-Specific Response Codes**

Code	Class	Description
0	Success	No Command-Specific Errors
1	-	Undefined
2	Error	Invalid Selection
3	Error	Passed Parameter Too Large
4	Error	Passed Parameter Too Small
5	Error	Too Few Data Bytes Received
6	Error	Device-Specific Command Error
7	Error	In Write Protect Mode
8	-	Undefined
9	Error	Invalid Burst Message
10	-	Undefined
11	Error	Invalid Device Variable Classification
12	Error	Invalid Units Code
13	Error	Invalid Burst Trigger Mode Selection Code
14 to 15	-	Undefined
16	Error	Access Restricted
17 to 31	-	Undefined
32	Error	Busy (A Delayed Response could not be initiated)
33	Error	Delayed Response Initiated
34	Error	Delayed Response Running
35	Error	Delayed Response Dead
36	Error	Delayed Response Conflict
37 to 127	-	Undefined

## 8.2.8 Command #105: Read Burst Mode Configuration

This command reads the Burst Mode configuration from the field device including: the Burst Mode Control Code, the command to be burst and a list of the Device Variables to be transmitted, the burst minimum and maximum update time and the condition for the maximum update time.

**Table 100. Request Data Bytes**

Byte	Format	Description
0	Unsigned-8	Burst Message

**Table 101. Response Data Bytes**

Byte	Format	Description
0	Unsigned-8	Burst Mode Control Code (see Section 8.4, Table 257)
1	Unsigned-8	Command Number of the response message to be transmitted
2	Unsigned-8	Device Variable Code assigned to Slot0 (see Section 9.1)
3	Unsigned-8	Device Variable Code assigned to Slot1 (see Section 9.1)
4	Unsigned-8	Device Variable Code assigned to Slot2 (see Section 9.1)
5	Unsigned-8	Device Variable Code assigned to Slot3 (see Section 9.1)
6	Unsigned-8	Device Variable Code assigned to Slot4 (see Section 9.1)
7	Unsigned-8	Device Variable Code assigned to Slot5 (see Section 9.1)
8	Unsigned-8	Device Variable Code assigned to Slot6 (see Section 9.1)
9	Unsigned-8	Device Variable Code assigned to Slot7 (see Section 9.1)
10	Unsigned-8	Burst Message
11	Unsigned-8	Total Number of Burst Messages
12 to 15	Time	Update Time in 1/32 of a millisecond
16 to 19	Time	Maximum Update Time in 1/32 of a millisecond
20	Enum	Burst Trigger Mode Code (see Section 8.4, Table 265)
21	Enum	Device Variable Classification for Trigger Value (see Section 8.4, Table 263)
22	Enum	Units Code (see Section 8.4, Table 252)
23 to 26	Float	Trigger Value

**Table 102. Command-Specific Response Codes**

Code	Class	Description
0	Success	No Command-Specific Errors
1 to 5	-	Undefined
6	Error	Device-Specific Command Error
7 to 8	-	Undefined
9	Error	Invalid Burst Message
10 to 31	-	Undefined
32	Error	Busy
33 to 127	-	Undefined

## 8.2.9 Command #107: Write Burst Device Variables

This command selects the Device Variables that will be used by a bursting device to be returned by a Command 9 in Burst Mode.

If the trigger mode isn't Continuous in Command 104 and the trigger source's Device Variable Classification does not match the new Slot 0 Device Variable, the new values will be accepted and Response Code "Burst Condition Conflict" will be returned. The field device corrects the classification, unit codes, reset to Trigger Mode Continuous and publish continuously at the Update Period until it receives another Command 104.

**Table 103. Request Data Bytes**

Byte	Format	Description
0	Unsigned-8	Device Variable Code assigned to Slot 0 (see Section 9.1)
1	Unsigned-8	Device Variable Code assigned to Slot 1 (see Section 9.1)
2	Unsigned-8	Device Variable Code assigned to Slot 2 (see Section 9.1)
3	Unsigned-8	Device Variable Code assigned to Slot 3 (see Section 9.1)
4	Unsigned-8	Device Variable Code assigned to Slot 4 (see Section 9.1)
5	Unsigned-8	Device Variable Code assigned to Slot 5 (see Section 9.1)
6	Unsigned-8	Device Variable Code assigned to Slot 6 (see Section 9.1)
7	Unsigned-8	Device Variable Code assigned to Slot 7 (see Section 9.1)
8	Unsigned-8	Burst Message

**Table 104. Response Data Bytes**

Byte	Format	Description
0	Unsigned-8	Device Variable Code assigned to Slot 0 (see Section 9.1)
1	Unsigned-8	Device Variable Code assigned to Slot 1 (see Section 9.1)
2	Unsigned-8	Device Variable Code assigned to Slot 2 (see Section 9.1)
3	Unsigned-8	Device Variable Code assigned to Slot 3 (see Section 9.1)
4	Unsigned-8	Device Variable Code assigned to Slot 4 (see Section 9.1)
5	Unsigned-8	Device Variable Code assigned to Slot 5 (see Section 9.1)
6	Unsigned-8	Device Variable Code assigned to Slot 6 (see Section 9.1)
7	Unsigned-8	Device Variable Code assigned to Slot 7 (see Section 9.1)
8	Unsigned-8	Burst Message

**Table 105. Command-Specific Response Codes**

Code	Class	Description
0	Success	No Command-Specific Errors
1	-	Undefined
2	Error	Invalid Selection
3 to 4	-	Undefined
5	Error	Too Few Data Bytes Received
6	Error	Device-Specific Command Error
7	Error	In Write Protect Mode
8	Warning	Burst Condition Conflict
9	Error	Invalid Burst Message
10 to 127	-	Undefined

## 8.2.10 Command #108: Write Burst Mode Command Number

This command selects the response message that the device transmits while in Burst Mode.

**Table 106. Request Data Bytes**

Byte	Format	Description
0	Unsigned-8	Command Number of the response message to be transmitted
1	Unsigned-8	Burst Message

**Table 107. Response Data Bytes**

Byte	Format	Description
0	Unsigned-8	Command Number of the response message to be transmitted
1	Unsigned-8	Burst Message

**Table 108. Command-Specific Response Codes**

Code	Class	Description
0	Success	No Command-Specific Errors
1	-	Undefined
2	Error	Invalid Selection
3 to 4	-	Undefined
5	Error	Too Few Data Bytes Received
6	Error	Device-Specific Command Error
7	Error	In Write Protect Mode
8	Warning	Burst Condition Conflict
9	Error	Invalid Burst Message
10 to 127	-	Undefined

The following command can be represented in burst messages:

**Table 109. Burst Messages**

Number	Command Description
1	Read Primary Variable
2	Read Loop Current and Percent of Range
3	Read Dynamic Variables and Loop Current
9	Read Device Variables with status
48	Read Additional Device Status

## 8.2.11 Command #109: Burst Mode Control

This command is used to enter and exit the Burst Mode on the field device.

**Table 110. Request Data Bytes**

Byte	Format	Description
0	Unsigned-8	Burst Mode Control Code (see Section 8.4, Table 257)
1	Unsigned-8	Burst Message

**Table 111. Response Data Bytes**

Byte	Format	Description
0	Unsigned-8	Burst Mode Control Code (see Section 8.4, Table 257)
1	Unsigned-8	Burst Message

**Table 112. Command-Specific Response Codes**

Code	Class	Description
0	Success	No Command-Specific Errors
1	-	Undefined
2	Error	Invalid Selection
3 to 4	-	Undefined
5	Error	Too Few Data Bytes Received
6	Error	Device-Specific Command Error
7	Error	In Write Protect Mode
8	Warning	Update Period Increased
9	Error	Insufficient bandwidth
10 to 15	-	Undefined
16	Error	Access Restricted
17 to 31	-	Undefined
32	Error	Busy (Delayed Response could not be initiated)
33	Error	Delayed Response Initiated
34	Error	Delayed Response Running
35	Error	Delayed Response Dead
36	Error	Delayed Response Conflict
37 to 127	-	Undefined

## 8.2.12 Catch Device Variable

This device does not support Catch Device Variable.

## 8.3 Device-Specific Commands

The following Device-Specific commands are implemented:

**Table 113. Device-Specific Commands available on EleHRT-24**

Number	Command Description
130	Read Array
131	Write Array
132	Read Param_E Parameters
133	Write Param_E Parameters
134	Read Param_BE Parameters
135	Write Param_BE Parameters
136	Read Param_F Parameters
137	Write Param_F Parameters
138	Read Param_D Parameters
139	Write Param_D Parameters
140	Read Param_U32 Parameters
141	Write Param_U32 Parameters
142	Read Param_S32 Parameters
143	Write Param_S32 Parameters
144	Read Param_Str8 Parameters
145	Write Param_Str8 Parameters
146	Read Param_Str4 Parameters
147	Write Param_Str4 Parameters
148	Read FST Torque Curve Data Header
149	Read FST Torque Curve
150	Read PST Curve Data Header
151	Read PST Curve Part1
152	Read PST Curve Part2
153	Read EFS Curve Data Header
154	Read EFS Curve Part1
155	Read EFS Curve Part2
156	Read Event Log Data Header
157	Read Event Log
158	Read Recorder Log Data Header
159	Read Recorder Log
160	Read T-Recorder Log Data Header
161	Read T-Recorder Log
162	Read Card Report
163	Write Card Report
164	Read Alarms, Warnings and Connection Logs Data Header
165	Read Alarms Log
166	Read Warnings Log
167	Read Connections Log
168	Read Actuator Commands
169	Write Actuator Commands
171	Read Actuator Status
172	Read PST Status

## 8.3.1 Command #130: Read Array

Reads the value of one actuator array data.

**Table 114. Request Data Bytes**

Byte	Format	Description
0	Enum	Array Code (see Section 10.1)

**Table 115. Response Data Bytes**

Byte	Format	Description
0	Enum	Array Code (see Section 10.1)
1 to 28	ASCII	Array Value

**Table 116. Command-Specific Response Codes**

Code	Class	Description
0	Success	No Command-Specific Errors
1	-	Undefined
2	Error	Invalid Selection
3 to 4	-	Undefined
5	Error	Too few data bytes received
6 to 31	-	Undefined
32	Error	Device Busy
33 to 127	-	Undefined

## 8.3.2 Command #131: Write Array

This command allows forcing the value of one array data.

**Table 117. Request Data Bytes**

Byte	Format	Description
0	Enum	Array Code (see Section 10.1)
1 to 28	ASCII	Array Value

**Table 118. Response Data Bytes**

Byte	Format	Description
0	Enum	Array Code (see Section 10.1)
1 to 28	ASCII	Array Value

**Table 119. Command-Specific Response Codes**

Code	Class	Description
0	Success	No Command-Specific Errors
1 to 4	-	Undefined
5	Error	Too few data bytes received
6	-	Undefined
7	Error	In Write Protect Mode
8 to 16	-	Undefined
17	Error	Invalid Array Code
18 to 31	-	Undefined
32	Error	Device Busy
33 to 127	-	Undefined

If a master tries to write a read only array, response code 7 (“In Write Protect Mode”) is generated.

### 8.3.3 Command #132: Read Param\_E Parameters

Reads the value of a Param\_E Parameter.

**Table 120. Request Data Bytes**

Byte	Format	Description
0	Enum-8	Param_E Code (See Section 10.2)

**Table 121. Response Data Bytes**

Byte	Format	Description
0	Enum-8	Param_E Code (See Section 10.2)
1 to 2	Enum-16	Param_E Value

**Table 122. Command-Specific Response Codes**

Code	Class	Description
0	Success	No Command-Specific Errors
1	-	Undefined
2	Error	Invalid Selection
3 to 4	-	Undefined
5	Error	Too Few Data Bytes Received
6 to 31	-	Undefined
32	Error	Busy
33 to 127	-	Undefined

## 8.3.4 Command #133: Write Param\_E Parameters

This command allows forcing the value of one Param\_E Parameter.

**Table 123. Request Data Bytes**

Byte	Format	Description
0	Enum-8	Param_E Code (See Section 10.2)
1 to 2	Enum-16	Param_E Value

**Table 124. Response Data Bytes**

Byte	Format	Description
0	Enum-8	Param_E Code (See Section 10.2)
1 to 2	Enum-16	Param_E Value

**Table 125. Command-Specific Response Codes**

Code	Class	Description
0	Success	No Command-Specific Errors
1 to 4	-	Undefined
5	Error	Too Few Data Bytes Received
6	-	Undefined
7	Error	In Write Protect Mode
8 to 16	-	Undefined
17	Error	Invalid Param_E Code
18 to 31	-	Undefined
32	Error	Busy
33 to 127	-	Undefined

If a master tries to write a read only parameter, response code 7 ("In Write Protect Mode") is generated. The modification of the value of the parameters is restricted by the permissions of the user level logged, see Appendix B for details.

## 8.3.5 Command #134: Read Param\_BE Parameters

Reads the value of a Param\_BE Parameter.

**Table 126. Request Data Bytes**

Byte	Format	Description
0	Enum-8	Param_BE Code (See Section 10.3)

**Table 127. Response Data Bytes**

Byte	Format	Description
0	Enum-8	Param_BE Code (See Section 10.3)
1 to 2	Bit Enum	Param_BE Value

**Table 128. Command-Specific Response Codes**

Code	Class	Description
0	Success	No Command-Specific Errors
1	-	Undefined
2	Error	Invalid Selection
3 to 4	-	Undefined
5	Error	Too Few Data Bytes Received
6 to 31	-	Undefined
32	Error	Busy
33 to 127	-	Undefined

## 8.3.6 Command #135: Write Param\_BE Parameters

This command allows forcing the value of one Param\_BE Parameter.

**Table 129. Request Data Bytes**

Byte	Format	Description
0	Enum-8	Param_BE Code (See Section 10.3)
1 to 2	Bit Enum	Param_BE Value

**Table 130. Response Data Bytes**

Byte	Format	Description
0	Enum-8	Param_BE Code (See Section 10.3)
1 to 2	Bit Enum	Param_BE Value

**Table 131. Command-Specific Response Codes**

Code	Class	Description
0	Success	No Command-Specific Errors
1 to 4	-	Undefined
5	Error	Too Few Data Bytes Received
6	-	Undefined
7	Error	In Write Protect Mode
8 to 16	-	Undefined
17	Error	Invalid Param_BE Code
18 to 31	-	Undefined
32	Error	Busy
33 to 127	-	Undefined

If a master tries to write a read only parameter, response code 7 ("In Write Protect Mode") is generated. The modification of the value of the parameters is restricted by the permissions of the user level logged, see Appendix B for details.

## 8.3.7 Command #136: Read Param\_F Parameters

Reads the value of a Param\_F Parameter.

**Table 132. Request Data Bytes**

Byte	Format	Description
0	Enum-8	Param_F Code (See Section 10.4)

**Table 133. Response Data Bytes**

Byte	Format	Description
0	Enum-8	Param_F Code (See Section 10.4)
1 to 4	Float	Param_F Value

**Table 134. Command-Specific Response Codes**

Code	Class	Description
0	Success	No Command-Specific Errors
1	-	Undefined
2	Error	Invalid Selection
3 to 4	-	Undefined
5	Error	Too Few Data Bytes Received
6 to 31	-	Undefined
32	Error	Busy
33 to 127	-	Undefined

### 8.3.8 Command #137: Write Param\_F Parameters

This command allows forcing the value of one Param\_F Parameter.

**Table 135. Request Data Bytes**

Byte	Format	Description
0	Enum-8	Param_F Code (See Section 10.4)
1 to 4	Float	Param_F Value

**Table 136. Response Data Bytes**

Byte	Format	Description
0	Enum-8	Param_F Code (See Section 10.4)
1 to 4	Float	Param_F Value

**Table 137. Command-Specific Response Codes**

Code	Class	Description
0	Success	No Command-Specific Errors
1 to 4	-	Undefined
5	Error	Too Few Data Bytes Received
6	-	Undefined
7	Error	In Write Protect Mode
8 to 16	-	Undefined
17	Error	Invalid Param_F Code
18 to 31	-	Undefined
32	Error	Busy
33 to 127	-	Undefined

If a master tries to write a read only parameter, response code 7 ("In Write Protect Mode") is generated. The modification of the value of the parameters is restricted by the permissions of the user level logged, see Appendix B for details.

### 8.3.9 Command #138: Read Param\_D Parameters

Reads the value of a Param\_D Parameter.

**Table 138. Request Data BytesTable**

Byte	Format	Description
0	Enum-8	Param_D Code (See Section 10.5)

**Table 139. Response Data Bytes**

Byte	Format	Description
0	Enum-8	Param_D Code (See Section 10.5)
1 to 3	Date	Param_D Value – Date
4 to 7	Time	Param_D Value – Time

**Table 140. Command-Specific Response Codes**

Code	Class	Description
0	Success	No Command-Specific Errors
1	-	Undefined
2	Error	Invalid Selection
3 to 4	-	Undefined
5	Error	Too Few Data Bytes Received
6 to 31	-	Undefined
32	Error	Busy
33 to 127	-	Undefined

## 8.3.10 Command #139: Write Param\_D Parameters

This command allows forcing the value of one Param\_D Parameter.

**Table 141. Request Data Bytes**

Byte	Format	Description
0	Enum-8	Param_D Code (See Section 10.5)
1 to 3	Date	Param_D Value – Date
4 to 7	Time	Param_D Value – Time

**Table 142. Response Data Bytes**

Byte	Format	Description
0	Enum-8	Param_D Code (See Section 10.5)
1 to 3	Date	Param_D Value – Date
4 to 7	Time	Param_D Value – Time

**Table 143. Command-Specific Response Codes**

Code	Class	Description
0	Success	No Command-Specific Errors
1 to 4	-	Undefined
5	Error	Too Few Data Bytes Received
6	-	Undefined
7	Error	In Write Protect Mode
8 to 16	-	Undefined
17	Error	Invalid Param_D Code
18 to 31	-	Undefined
32	Error	Busy
33 to 127	-	Undefined

If a master tries to write a read only parameter, response code 7 (“In Write Protect Mode”) is generated. The modification of the value of the parameters is restricted by the permissions of the user level logged, see Appendix B for details.

### 8.3.11 Command #140: Read Param\_U32 Parameters

Reads the value of a Param\_U32 Parameter.

**Table 144. Request Data Bytes**

Byte	Format	Description
0	Enum-8	Param_U32 Code (See Section 10.6)

**Table 145. Response Data Bytes**

Byte	Format	Description
0	Enum-8	Param_U32 Code (See Section 10.6)
1 to 4	Unsigned Int-32	Param_U32 Value

**Table 146. Command-Specific Response Codes**

Code	Class	Description
0	Success	No Command-Specific Errors
1	-	Undefined
2	Error	Invalid Selection
3 to 4	-	Undefined
5	Error	Too Few Data Bytes Received
6 to 31	-	Undefined
32	Error	Busy
33 to 127	-	Undefined

## 8.3.12 Command #141: Write Param\_U32 Parameters

This command allows forcing the value of one Param\_U32 Parameter.

**Table 147. Request Data Bytes**

Byte	Format	Description
0	Enum-8	Param_U32 Code (See Section 10.6)
1 to 4	Unsigned Int-32	Param_U32 Value

**Table 148. Response Data Bytes**

Byte	Format	Description
0	Enum-8	Param_U32 Code (See Section 10.6)
1 to 4	Unsigned Int-32	Param_U32 Value

**Table 149. Command-Specific Response Codes**

Code	Class	Description
0	Success	No Command-Specific Errors
1 to 4	-	Undefined
5	Error	Too Few Data Bytes Received
6	-	Undefined
7	Error	In Write Protect Mode
8 to 16	-	Undefined
17	Error	Invalid Param_U32 Code
18 to 31	-	Undefined
32	Error	Busy
33 to 127	-	Undefined

If a master tries to write a read only parameter, response code 7 (“In Write Protect Mode”) is generated. The modification of the value of the parameters is restricted by the permissions of the user level logged, see Appendix B for details.

### 8.3.13 Command #142: Read Param\_S32 Parameters

Reads the value of a Param\_S32 Parameter.

**Table 150. Request Data Bytes**

Byte	Format	Description
0	Enum-8	Param_S32 Code (See Section 10.7)

**Table 151. Response Data Bytes**

Byte	Format	Description
0	Enum-8	Param_S32 Code (See Section 10.7)
1 to 4	Signed Int-32	Param_S32 Value

**Table 152. Command-Specific Response Codes**

Code	Class	Description
0	Success	No Command-Specific Errors
1	-	Undefined
2	Error	Invalid Selection
3 to 4	-	Undefined
5	Error	Too Few Data Bytes Received
6 to 31	-	Undefined
32	Error	Busy
33 to 127	-	Undefined

## 8.3.14 Command #143: Write Param\_S32 Parameters

This command allows forcing the value of one Param\_S32 Parameter.

**Table 153. Request Data Bytes**

Byte	Format	Description
0	Enum-8	Param_S32 Code (See Section 10.7)
1 to 4	Signed Int-32	Param_S32 Value

**Table 154. Response Data Bytes**

Byte	Format	Description
0	Enum-8	Param_S32 Code (See Section 10.7)
1 to 4	Signed Int-32	Param_S32 Value

**Table 155. Command-Specific Response Codes**

Code	Class	Description
0	Success	No Command-Specific Errors
1 to 4	-	Undefined
5	Error	Too Few Data Bytes Received
6	-	Undefined
7	Error	In Write Protect Mode
8 to 16	-	Undefined
17	Error	Invalid Param_S32 Code
18 to 31	-	Undefined
32	Error	Busy
33 to 127	-	Undefined

If a master tries to write a read only parameter, response code 7 ("In Write Protect Mode") is generated. The modification of the value of the parameters is restricted by the permissions of the user level logged, see Appendix B for details.

### 8.3.15 Command #144: Read Param\_Str8 Parameters

Reads the value of a Param\_Str8 Parameter.

**Table 156. Request Data Bytes**

Byte	Format	Description
0	Enum-8	Param_Str8 Code (See Section 10.8)

**Table 157. Response Data Bytes**

Byte	Format	Description
0	Enum-8	Param_Str8 Code (See Section 10.8)
1 to 8	ASCII	Param_Str8 Value

**Table 158. Command-Specific Response Codes**

Code	Class	Description
0	Success	No Command-Specific Errors
1	-	Undefined
2	Error	Invalid Selection
3 to 4	-	Undefined
5	Error	Too Few Data Bytes Received
6 to 31	-	Undefined
32	Error	Busy
33 to 127	-	Undefined

## 8.3.16 Command #145: Write Param\_Str8 Parameters

This command allows forcing the value of one Param\_Str8 Parameter.

**Table 159. Request Data Bytes**

Byte	Format	Description
0	Enum-8	Param_Str8 Code (See Section 10.8)
1 to 8	ASCII	Param_Str8 Value

**Table 160. Response Data Bytes**

Byte	Format	Description
0	Enum-8	Param_Str8 Code (See Section 10.8)
1 to 8	ASCII	Param_Str8 Value

**Table 161. Command-Specific Response Codes**

Code	Class	Description
0	Success	No Command-Specific Errors
1 to 4	-	Undefined
5	Error	Too Few Data Bytes Received
6	-	Undefined
7	Error	In Write Protect Mode
8 to 16	-	Undefined
17	Error	Invalid Param_Str8 Code
18 to 31	-	Undefined
32	Error	Busy
33 to 127	-	Undefined

If a master tries to write a read only parameter, response code 7 ("In Write Protect Mode") is generated. The modification of the value of the parameters is restricted by the permissions of the user level logged, see Appendix B for details.

## 8.3.17 Command #146: Read Param\_Str4 Parameters

Reads the value of a Param\_Str4 Parameter.

**Table 162. Request Data Bytes**

Byte	Format	Description
0	Enum-8	Param_Str4 Code (See Section 10.9)

**Table 163. Response Data Bytes**

Byte	Format	Description
0	Enum-8	Param_Str4 Code (See Section 10.9)
1 to 4	ASCII	Param_Str4 Value

**Table 164. Command-Specific Response Codes**

Code	Class	Description
0	Success	No Command-Specific Errors
1	-	Undefined
2	Error	Invalid Selection
3 to 4	-	Undefined
5	Error	Too Few Data Bytes Received
6 to 31	-	Undefined
32	Error	Busy
33 to 127	-	Undefined

## 8.3.18 Command #147: Write Param\_Str4 Parameters

This command allows forcing the value of one Param\_Str4 Parameter.

**Table 165. Request Data Bytes**

Byte	Format	Description
0	Enum-8	Param_Str4 Code (See Section 10.9)
1 to 4	ASCII	Param_Str4 Value

**Table 166. Response Data Bytes**

Byte	Format	Description
0	Enum-8	Param_Str4 Code (See Section 10.9)
1 to 4	ASCII	Param_Str4 Value

**Table 167. Command-Specific Response Codes**

Code	Class	Description
0	Success	No Command-Specific Errors
1 to 4	-	Undefined
5	Error	Too Few Data Bytes Received
6	-	Undefined
7	Error	In Write Protect Mode
8 to 16	-	Undefined
17	Error	Invalid Param_Str4 Code
18 to 31	-	Undefined
32	Error	Busy
33 to 127	-	Undefined

If a master tries to write a read only parameter, response code 7 ("In Write Protect Mode") is generated. The modification of the value of the parameters is restricted by the permissions of the user level logged, see Appendix B for details.

### 8.3.19 Command #148: Read FST Torque Curve Data Header

This command allows reading the header data of one FST Torque Curve.

**Table 168. Request Data Bytes**

Byte	Format	Description
0	Enum-8	FST Torque Curve ID (See Section 10.10)
1	Enum-8	FST Torque Curve Type (See Section 10.11)

**Table 169. Response Data Bytes**

Byte	Format	Description
0	Enum-8	FST Torque Curve ID (See Section 10.10)
1	Enum-8	FST Torque Curve Type (See Section 10.11)
2 to 4	Date	FST Date
5 to 8	Time	FST Time
9	Signed Int-8	Electronic Temperature (°C)
10	Signed Int-8	Terminal Board Temperature (°C)
11	Signed Int-8	Motor Temperature (°C)
12 to 13	Unsigned Int-16	Voltage (V)
14 to 15	Unsigned Int-16	Stroke Time (s)

**Table 170. Command-Specific Response Codes**

Code	Class	Description
0	Success	No Command-Specific Errors
1	-	Undefined
2	Error	Invalid Selection
3 to 4	-	Undefined
5	Error	Too Few Data Bytes Received
6 to 31	-	Undefined
32	Error	Busy
33 to 127	-	Undefined

If the combination of the FST Torque Curve ID and the FST Torque Curve Type corresponds to a not existing FST Torque Curve, the FST Date and FST Time are fixed respectively to 6th February 2136 and 06:28:15.

## 8.3.20 Command #149: Read FST Torque Curve

This command allows reading the samples of one FST Torque Curve.

**Table 171. Request Data Bytes**

Byte	Format	Description
0	Unsigned Int-8	FST Transaction ID (0 to 2)
1	Enum-8	FST Torque Curve ID (See Section 10.10)
2	Enum-8	FST Torque Curve Type (See Section 10.11)

**Table 172. Response Data Bytes (Transaction ID = 0)**

Byte	Format	Description
0	Unsigned Int-8	FST Transaction ID = 0
1	Enum-8	FST Torque Curve ID (See Section 10.10)
2	Enum-8	FST Torque Curve Type (See Section 10.11)
3 to 4	Unsigned Int-16	Torque at position 0%
5 to 6	Unsigned Int-16	Torque at position 1%
7 to 8	Unsigned Int-16	Torque at position 2%
9 to 10	Unsigned Int-16	Torque at position 3%
11 to 12	Unsigned Int-16	Torque at position 4%
13 to 14	Unsigned Int-16	Torque at position 5%
15 to 16	Unsigned Int-16	Torque at position 6%
17 to 18	Unsigned Int-16	Torque at position 7%
19 to 20	Unsigned Int-16	Torque at position 8%
21 to 22	Unsigned Int-16	Torque at position 9%
23 to 24	Unsigned Int-16	Torque at position 10%
25 to 26	Unsigned Int-16	Torque at position 11%
27 to 28	Unsigned Int-16	Torque at position 12%
29 to 30	Unsigned Int-16	Torque at position 13%
31 to 32	Unsigned Int-16	Torque at position 14%
33 to 34	Unsigned Int-16	Torque at position 15%
35 to 36	Unsigned Int-16	Torque at position 16%
37 to 38	Unsigned Int-16	Torque at position 17%
39 to 40	Unsigned Int-16	Torque at position 18%
41 to 42	Unsigned Int-16	Torque at position 19%
43 to 44	Unsigned Int-16	Torque at position 20%
45 to 46	Unsigned Int-16	Torque at position 21%
47 to 48	Unsigned Int-16	Torque at position 22%
49 to 50	Unsigned Int-16	Torque at position 23%
51 to 52	Unsigned Int-16	Torque at position 24%
53 to 54	Unsigned Int-16	Torque at position 25%
55 to 56	Unsigned Int-16	Torque at position 26%
57 to 58	Unsigned Int-16	Torque at position 27%
59 to 60	Unsigned Int-16	Torque at position 28%
61 to 62	Unsigned Int-16	Torque at position 29%
63 to 64	Unsigned Int-16	Torque at position 30%
65 to 66	Unsigned Int-16	Torque at position 31%
67 to 68	Unsigned Int-16	Torque at position 32%
69 to 70	Unsigned Int-16	Torque at position 33%

**Table 173. Response Data Bytes (Transaction ID = 1)**

Byte	Format	Description
0	Unsigned Int-8	FST Transaction ID = 1
1	Enum-8	FST Torque Curve ID (See Section 10.10)
2	Enum-8	FST Torque Curve Type (See Section 10.11)
3 to 4	Unsigned Int-16	Torque at position 34%
5 to 6	Unsigned Int-16	Torque at position 35%
7 to 8	Unsigned Int-16	Torque at position 36%
9 to 10	Unsigned Int-16	Torque at position 37%
11 to 12	Unsigned Int-16	Torque at position 38%
13 to 14	Unsigned Int-16	Torque at position 39%
15 to 16	Unsigned Int-16	Torque at position 40%
17 to 18	Unsigned Int-16	Torque at position 41%
19 to 20	Unsigned Int-16	Torque at position 42%
21 to 22	Unsigned Int-16	Torque at position 43%
23 to 24	Unsigned Int-16	Torque at position 44%
25 to 26	Unsigned Int-16	Torque at position 45%
27 to 28	Unsigned Int-16	Torque at position 46%
29 to 30	Unsigned Int-16	Torque at position 47%
31 to 32	Unsigned Int-16	Torque at position 48%
33 to 34	Unsigned Int-16	Torque at position 49%
35 to 36	Unsigned Int-16	Torque at position 50%
37 to 38	Unsigned Int-16	Torque at position 51%
39 to 40	Unsigned Int-16	Torque at position 52%
41 to 42	Unsigned Int-16	Torque at position 53%
43 to 44	Unsigned Int-16	Torque at position 54%
45 to 46	Unsigned Int-16	Torque at position 55%
47 to 48	Unsigned Int-16	Torque at position 56%
49 to 50	Unsigned Int-16	Torque at position 57%
51 to 52	Unsigned Int-16	Torque at position 58%
53 to 54	Unsigned Int-16	Torque at position 59%
55 to 56	Unsigned Int-16	Torque at position 60%
57 to 58	Unsigned Int-16	Torque at position 61%
59 to 60	Unsigned Int-16	Torque at position 62%
61 to 62	Unsigned Int-16	Torque at position 63%
63 to 64	Unsigned Int-16	Torque at position 64%
65 to 66	Unsigned Int-16	Torque at position 65%
67 to 68	Unsigned Int-16	Torque at position 66%
69 to 70	Unsigned Int-16	Torque at position 67%

**Table 174. Response Data Bytes (Transaction ID = 2)**

Byte	Format	Description
0	Unsigned Int-8	FST Transaction ID = 2
1	Enum-8	FST Torque Curve ID (See Section 10.10)
2	Enum-8	FST Torque Curve Type (See Section 10.11)
3 to 4	Unsigned Int-16	Torque at position 68%
5 to 6	Unsigned Int-16	Torque at position 69%
7 to 8	Unsigned Int-16	Torque at position 70%
9 to 10	Unsigned Int-16	Torque at position 71%
11 to 12	Unsigned Int-16	Torque at position 72%
13 to 14	Unsigned Int-16	Torque at position 73%
15 to 16	Unsigned Int-16	Torque at position 74%
17 to 18	Unsigned Int-16	Torque at position 75%
19 to 20	Unsigned Int-16	Torque at position 76%
21 to 22	Unsigned Int-16	Torque at position 77%
23 to 24	Unsigned Int-16	Torque at position 78%
25 to 26	Unsigned Int-16	Torque at position 79%
27 to 28	Unsigned Int-16	Torque at position 80%
29 to 30	Unsigned Int-16	Torque at position 81%
31 to 32	Unsigned Int-16	Torque at position 82%
33 to 34	Unsigned Int-16	Torque at position 83%
35 to 36	Unsigned Int-16	Torque at position 84%
37 to 38	Unsigned Int-16	Torque at position 85%
39 to 40	Unsigned Int-16	Torque at position 86%
41 to 42	Unsigned Int-16	Torque at position 87%
43 to 44	Unsigned Int-16	Torque at position 88%
45 to 46	Unsigned Int-16	Torque at position 89%
47 to 48	Unsigned Int-16	Torque at position 90%
49 to 50	Unsigned Int-16	Torque at position 91%
51 to 52	Unsigned Int-16	Torque at position 92%
53 to 54	Unsigned Int-16	Torque at position 93%
55 to 56	Unsigned Int-16	Torque at position 94%
57 to 58	Unsigned Int-16	Torque at position 95%
59 to 60	Unsigned Int-16	Torque at position 96%
61 to 62	Unsigned Int-16	Torque at position 97%
63 to 64	Unsigned Int-16	Torque at position 98%
65 to 66	Unsigned Int-16	Torque at position 99%
67 to 68	Unsigned Int-16	Torque at position 100%
69 to 70	Unsigned Int-16	Not Used

**Table 175. Command-Specific Response Codes**

Code	Class	Description
0	Success	No Command-Specific Errors
1	-	Undefined
2	Error	Invalid Selection
3 to 4	-	Undefined
5	Error	Too Few Data Bytes Received
6 to 31	-	Undefined
32	Error	Busy
33 to 127	-	Undefined

## 8.3.21 Command #150: Read PST Curve Data Header

This command allows reading the header data of one PST Curve.

**Table 176. Request Data Bytes**

Byte	Format	Description
0	Enum-8	PST Curve ID (See Section 10.12)

**Table 177. Response Data Bytes**

Byte	Format	Description
0	Enum-8	PST Curve ID (See Section 10.12)
1 to 3	Date	PST Date
4 to 7	Time	PST Time
8	Signed Int-8	Electronic Temperature (°C)
9	Signed Int-8	Terminal Board Temperature (°C)
10	Signed Int-8	Motor Temperature (°C)
11	Signed Int-8	EFS Card Temperature (°C)
12 to 13	Unsigned Int-16	Voltage (V)
14	Enum-8	PST Result (See Section 10.13)
15	Enum-8	PST Direction (See Section 10.14)
16 to 19	Float	T-PST (s)
20 to 23	Float	T-RET (s)
24 to 27	Float	OV-TR (%)
28	Unsigned Int-8	PST Travel Limit (%)
29	Enum-8	PST Mode (See Section 10.15)
30	Bit Enumerated	PST Status (See Section 10.16)
31 to 34	Bit Enumerated	PST Reset Conditions (See Section 10.17)

**Table 178. Command-Specific Response Codes**

Code	Class	Description
0	Success	No Command-Specific Errors
1	-	Undefined
2	Error	Invalid Selection
3 to 4	-	Undefined
5	Error	Too Few Data Bytes Received
6 to 31	-	Undefined
32	Error	Busy
33 to 127	-	Undefined

If the PST Torque Curve ID corresponds to a not existing PST Torque Curve, the PST Date and PST Time are fixed respectively to 6th February 2136 and 06:28:15.

## 8.3.22 Command #151: Read PST Curve Part1

This command allows reading the first 51 samples of one PST Curve.

**Table 179. Request Data Bytes**

Byte	Format	Description
0	Unsigned Int-8	PST Part1 Transaction ID (0 to 2)
1	Enum-8	PST Curve ID (See Section 10.12)

**Table 180. Response Data Bytes (Transaction ID = 0)**

Byte	Format	Description
0	Unsigned Int-8	PST Part1 Transaction ID = 0
1	Enum-8	PST Curve ID (See Section 10.12)
2 to 5	Float	T-PST: elapsed time from PST command
6 to 9	Unsigned Int-16	T-PST: elapsed time to reach position 1% (Open PST) or position 99% (Close PST)
10 to 13	Unsigned Int-16	T-PST: elapsed time to reach position 2% (Open PST) or position 98% (Close PST)
14 to 17	Unsigned Int-16	T-PST: elapsed time to reach position 3% (Open PST) or position 97% (Close PST)
18 to 21	Unsigned Int-16	T-PST: elapsed time to reach position 4% (Open PST) or position 96% (Close PST)
22 to 25	Unsigned Int-16	T-PST: elapsed time to reach position 5% (Open PST) or position 95% (Close PST)
26 to 29	Unsigned Int-16	T-PST: elapsed time to reach position 6% (Open PST) or position 94% (Close PST)
30 to 33	Unsigned Int-16	T-PST: elapsed time to reach position 7% (Open PST) or position 93% (Close PST)
34 to 37	Unsigned Int-16	T-PST: elapsed time to reach position 8% (Open PST) or position 92% (Close PST)
38 to 41	Unsigned Int-16	T-PST: elapsed time to reach position 9% (Open PST) or position 91% (Close PST)
42 to 45	Unsigned Int-16	T-PST: elapsed time to reach position 10% (Open PST) or position 90% (Close PST)
46 to 49	Unsigned Int-16	T-PST: elapsed time to reach position 11% (Open PST) or position 89% (Close PST)
50 to 53	Unsigned Int-16	T-PST: elapsed time to reach position 12% (Open PST) or position 88% (Close PST)
54 to 57	Unsigned Int-16	T-PST: elapsed time to reach position 13% (Open PST) or position 87% (Close PST)
58 to 61	Unsigned Int-16	T-PST: elapsed time to reach position 14% (Open PST) or position 86% (Close PST)
62 to 65	Unsigned Int-16	T-PST: elapsed time to reach position 15% (Open PST) or position 85% (Close PST)
66 to 69	Unsigned Int-16	T-PST: elapsed time to reach position 16% (Open PST) or position 84% (Close PST)

**Table 181. Response Data Bytes (Transaction ID = 1)**

Byte	Format	Description
0	Unsigned Int-8	PST Part1 Transaction ID = 1
1	Enum-8	PST Curve ID (See Section 10.12)
2 to 5	Float	T-PST: elapsed time to reach position 17% (Open PST) or position 83% (Close PST)
6 to 9	Float	T-PST: elapsed time to reach position 18% (Open PST) or position 82% (Close PST)
10 to 13	Float	T-PST: elapsed time to reach position 19% (Open PST) or position 81% (Close PST)
14 to 17	Float	T-PST: elapsed time to reach position 20% (Open PST) or position 80% (Close PST)
18 to 21	Float	T-PST: elapsed time to reach position 21% (Open PST) or position 79% (Close PST)
22 to 25	Float	T-PST: elapsed time to reach position 22% (Open PST) or position 78% (Close PST)
26 to 29	Float	T-PST: elapsed time to reach position 23% (Open PST) or position 77% (Close PST)
30 to 33	Float	T-PST: elapsed time to reach position 24% (Open PST) or position 76% (Close PST)
34 to 37	Float	T-PST: elapsed time to reach position 25% (Open PST) or position 75% (Close PST)
38 to 41	Float	T-PST: elapsed time to reach position 26% (Open PST) or position 74% (Close PST)
42 to 45	Float	T-PST: elapsed time to reach position 27% (Open PST) or position 73% (Close PST)
46 to 49	Float	T-PST: elapsed time to reach position 28% (Open PST) or position 72% (Close PST)
50 to 53	Float	T-PST: elapsed time to reach position 29% (Open PST) or position 71% (Close PST)
54 to 57	Float	T-PST: elapsed time to reach position 30% (Open PST) or position 70% (Close PST)
58 to 61	Float	T-PST: elapsed time to reach position 31% (Open PST) or position 69% (Close PST)
62 to 65	Float	T-PST: elapsed time to reach position 32% (Open PST) or position 68% (Close PST)
66 to 69	Float	T-PST: elapsed time to reach position 33% (Open PST) or position 67% (Close PST)

**Table 182. Response Data Bytes (Transaction ID = 2)**

Byte	Format	Description
0	Unsigned Int-8	PST Part1 Transaction ID = 2
1	Enum-8	PST Curve ID (See Section 10.12)
2 to 5	Float	T-PST: elapsed time to reach position 34% (Open PST) or position 66% (Close PST)
6 to 9	Float	T-PST: elapsed time to reach position 35% (Open PST) or position 65% (Close PST)
10 to 13	Float	T-PST: elapsed time to reach position 36% (Open PST) or position 64% (Close PST)
14 to 17	Float	T-PST: elapsed time to reach position 37% (Open PST) or position 63% (Close PST)
18 to 21	Float	T-PST: elapsed time to reach position 38% (Open PST) or position 62% (Close PST)
22 to 25	Float	T-PST: elapsed time to reach position 39% (Open PST) or position 61% (Close PST)
26 to 29	Float	T-PST: elapsed time to reach position 40% (Open PST) or position 60% (Close PST)
30 to 33	Float	T-PST: elapsed time to reach position 41% (Open PST) or position 59% (Close PST)
34 to 37	Float	T-PST: elapsed time to reach position 42% (Open PST) or position 58% (Close PST)
38 to 41	Float	T-PST: elapsed time to reach position 43% (Open PST) or position 57% (Close PST)
42 to 45	Float	T-PST: elapsed time to reach position 44% (Open PST) or position 56% (Close PST)
46 to 49	Float	T-PST: elapsed time to reach position 45% (Open PST) or position 55% (Close PST)
50 to 53	Float	T-PST: elapsed time to reach position 46% (Open PST) or position 54% (Close PST)
54 to 57	Float	T-PST: elapsed time to reach position 47% (Open PST) or position 53% (Close PST)
58 to 61	Float	T-PST: elapsed time to reach position 48% (Open PST) or position 52% (Close PST)
62 to 65	Float	T-PST: elapsed time to reach position 49% (Open PST) or position 51% (Close PST)
66 to 69	Float	T-PST: elapsed time to reach position 50% (Open PST) or position 50% (Close PST)

**Table 183. Command-Specific Response Codes**

Code	Class	Description
0	Success	No Command-Specific Errors
1	-	Undefined
2	Error	Invalid Selection
3 to 4	-	Undefined
5	Error	Too Few Data Bytes Received
6 to 31	-	Undefined
32	Error	Busy
33 to 127	-	Undefined

## 8.3.23 Command #152: Read PST Curve Part2

This command allows reading the last 51 samples of one PST Curve.

**Table 184. Request Data Bytes**

Byte	Format	Description
0	Unsigned Int-8	PST Part2 Transaction ID (0 to 2)
1	Enum-8	PST Curve ID (See Section 10.12)

**Table 185. Response Data Bytes (Transaction ID = 0)**

Byte	Format	Description
0	Unsigned Int-8	PST Part2 Transaction ID = 0
1	Enum-8	PST Curve ID (See Section 10.12)
2 to 5	Float	T-RET: elapsed time to reach position 1% (Open PST) or position 99% (Close PST)
6 to 9	Float	T-RET: elapsed time to reach position 2% (Open PST) or position 98% (Close PST)
10 to 13	Float	T-RET: elapsed time to reach position 3% (Open PST) or position 97% (Close PST)
14 to 17	Float	T-RET: elapsed time to reach position 4% (Open PST) or position 96% (Close PST)
18 to 21	Float	T-RET: elapsed time to reach position 5% (Open PST) or position 95% (Close PST)
22 to 25	Float	T-RET: elapsed time to reach position 6% (Open PST) or position 94% (Close PST)
26 to 29	Float	T-RET: elapsed time to reach position 7% (Open PST) or position 93% (Close PST)
30 to 33	Float	T-RET: elapsed time to reach position 8% (Open PST) or position 92% (Close PST)
34 to 37	Float	T-RET: elapsed time to reach position 9% (Open PST) or position 91% (Close PST)
38 to 41	Float	T-RET: elapsed time to reach position 10% (Open PST) or position 90% (Close PST)
42 to 45	Float	T-RET: elapsed time to reach position 11% (Open PST) or position 89% (Close PST)
46 to 49	Float	T-RET: elapsed time to reach position 12% (Open PST) or position 88% (Close PST)
50 to 53	Float	T-RET: elapsed time to reach position 13% (Open PST) or position 87% (Close PST)
54 to 57	Float	T-RET: elapsed time to reach position 14% (Open PST) or position 86% (Close PST)
58 to 61	Float	T-RET: elapsed time to reach position 15% (Open PST) or position 85% (Close PST)
62 to 65	Float	T-RET: elapsed time to reach position 16% (Open PST) or position 84% (Close PST)
66 to 69	Float	T-RET: elapsed time to reach position 17% (Open PST) or position 83% (Close PST)

**Table 186. Response Data Bytes (Transaction ID = 1)**

Byte	Format	Description
0	Unsigned Int-8	PST Part2 Transaction ID = 1
1	Enum-8	PST Curve ID (See Section 10.12)
2 to 5	Float	T-RET: elapsed time to reach position 18% (Open PST) or position 82% (Close PST)
6 to 9	Float	T-RET: elapsed time to reach position 19% (Open PST) or position 81% (Close PST)
10 to 13	Float	T-RET: elapsed time to reach position 20% (Open PST) or position 80% (Close PST)
14 to 17	Float	T-RET: elapsed time to reach position 21% (Open PST) or position 79% (Close PST)
18 to 21	Float	T-RET: elapsed time to reach position 22% (Open PST) or position 78% (Close PST)
22 to 25	Float	T-RET: elapsed time to reach position 23% (Open PST) or position 77% (Close PST)
26 to 29	Float	T-RET: elapsed time to reach position 24% (Open PST) or position 76% (Close PST)
30 to 33	Float	T-RET: elapsed time to reach position 25% (Open PST) or position 75% (Close PST)
34 to 37	Float	T-RET: elapsed time to reach position 26% (Open PST) or position 74% (Close PST)
38 to 41	Float	T-RET: elapsed time to reach position 27% (Open PST) or position 73% (Close PST)
42 to 45	Float	T-RET: elapsed time to reach position 28% (Open PST) or position 72% (Close PST)
46 to 49	Float	T-RET: elapsed time to reach position 29% (Open PST) or position 71% (Close PST)
50 to 53	Float	T-RET: elapsed time to reach position 30% (Open PST) or position 70% (Close PST)
54 to 57	Float	T-RET: elapsed time to reach position 31% (Open PST) or position 69% (Close PST)
58 to 61	Float	T-RET: elapsed time to reach position 32% (Open PST) or position 68% (Close PST)
62 to 65	Float	T-RET: elapsed time to reach position 33% (Open PST) or position 67% (Close PST)
66 to 69	Float	T-RET: elapsed time to reach position 34% (Open PST) or position 66% (Close PST)

**Table 187. Response Data Bytes (Transaction ID = 2)**

Byte	Format	Description
0	Unsigned Int-8	PST Part1 Transaction ID = 2
1	Enum-8	PST Curve ID (See Section 10.12)
2 to 5	Float	T-RET: elapsed time to reach position 35% (Open PST) or position 65% (Close PST)
6 to 9	Float	T-RET: elapsed time to reach position 36% (Open PST) or position 64% (Close PST)
10 to 13	Float	T-RET: elapsed time to reach position 37% (Open PST) or position 63% (Close PST)
14 to 17	Float	T-RET: elapsed time to reach position 38% (Open PST) or position 62% (Close PST)
18 to 21	Float	T-RET: elapsed time to reach position 39% (Open PST) or position 61% (Close PST)
22 to 25	Float	T-RET: elapsed time to reach position 40% (Open PST) or position 60% (Close PST)
26 to 29	Float	T-RET: elapsed time to reach position 41% (Open PST) or position 59% (Close PST)
30 to 33	Float	T-RET: elapsed time to reach position 42% (Open PST) or position 58% (Close PST)
34 to 37	Float	T-RET: elapsed time to reach position 43% (Open PST) or position 57% (Close PST)
38 to 41	Float	T-RET: elapsed time to reach position 44% (Open PST) or position 56% (Close PST)
42 to 45	Float	T-RET: elapsed time to reach position 45% (Open PST) or position 55% (Close PST)
46 to 49	Float	T-RET: elapsed time to reach position 46% (Open PST) or position 54% (Close PST)
50 to 53	Float	T-RET: elapsed time to reach position 47% (Open PST) or position 53% (Close PST)
54 to 57	Float	T-RET: elapsed time to reach position 48% (Open PST) or position 52% (Close PST)
58 to 61	Float	T-RET: elapsed time to reach position 49% (Open PST) or position 51% (Close PST)
62 to 65	Float	T-RET: elapsed time to reach position 50% (Open PST) or position 50% (Close PST)
66 to 69	Float	Not Used

**Table 188. Command-Specific Response Codes**

Code	Class	Description
0	Success	No Command-Specific Errors
1	-	Undefined
2	Error	Invalid Selection
3 to 4	-	Undefined
5	Error	Too Few Data Bytes Received
6 to 31	-	Undefined
32	Error	Busy
33 to 127	-	Undefined

### 8.3.24 Command #153: Read EFS Curve Data Header

This command allows reading the header data of one EFS Curve.

**Table 189. Request Data Bytes**

Byte	Format	Description
0	Enum-8	EFS Curve ID (See Section 10.18)

**Table 190. Response Data Bytes**

Byte	Format	Description
0	Enum-8	EFS Curve ID (See Section 10.18)
1 to 3	Date	EFS Curve Date
4 to 7	Time	EFS Curve Time
8	Signed Int-8	Electronic Temperature (°C)
9	Signed Int-8	Terminal Board Temperature (°C)
10	Signed Int-8	Motor Temperature (°C)
11	Signed Int-8	EFS Card Temperature (°C)
12 to 13	Unsigned Int-16	Voltage (V)
14	Unsigned Int-8	Not Used
15	Enum-8	EFS Direction (See Section 10.14)

**Table 191. Command-Specific Response Codes**

Code	Class	Description
0	Success	No Command-Specific Errors
1	-	Undefined
2	Error	Invalid Selection
3 to 4	-	Undefined
5	Error	Too Few Data Bytes Received
6 to 31	-	Undefined
32	Error	Busy
33 to 127	-	Undefined

If the EFS Curve ID corresponds to a not existing EFS Curve, the EFS Curve Date and EFS Curve Time are fixed respectively to 6th February 2136 and 06:28:15.

## 8.3.25 Command #154: Read EFS Curve Part1

This command allows reading the first 51 samples of one EFS Curve.

**Table 192. Request Data Bytes**

Byte	Format	Description
0	Unsigned Int-8	EFS Part1 Transaction ID (0 to 2)
1	Enum-8	EFS Curve ID (See Section 10.18)

**Table 193. Response Data Bytes (Transaction ID = 0)**

Byte	Format	Description
0	Unsigned Int-8	EFS Part1 Transaction ID = 0
1	Enum-8	EFS Curve ID (See Section 10.18)
2 to 5	Float	T-EFS: elapsed time from EFS command
6 to 9	Float	T-EFS: elapsed time to reach position 1% (Open EFS) or position 99% (Close EFS)
10 to 13	Float	T-EFS: elapsed time to reach position 2% (Open EFS) or position 98% (Close EFS)
14 to 17	Float	T-EFS: elapsed time to reach position 3% (Open EFS) or position 97% (Close EFS)
18 to 21	Float	T-EFS: elapsed time to reach position 4% (Open EFS) or position 96% (Close EFS)
22 to 25	Float	T-EFS: elapsed time to reach position 5% (Open EFS) or position 95% (Close EFS)
26 to 29	Float	T-EFS: elapsed time to reach position 6% (Open EFS) or position 94% (Close EFS)
30 to 33	Float	T-EFS: elapsed time to reach position 7% (Open EFS) or position 93% (Close EFS)
34 to 37	Float	T-EFS: elapsed time to reach position 8% (Open EFS) or position 92% (Close EFS)
38 to 41	Float	T-EFS: elapsed time to reach position 9% (Open EFS) or position 91% (Close EFS)
42 to 45	Float	T-EFS: elapsed time to reach position 10% (Open EFS) or position 90% (Close EFS)
46 to 49	Float	T-EFS: elapsed time to reach position 11% (Open EFS) or position 89% (Close EFS)
50 to 53	Float	T-EFS: elapsed time to reach position 12% (Open EFS) or position 88% (Close EFS)
54 to 57	Float	T-EFS: elapsed time to reach position 13% (Open EFS) or position 87% (Close EFS)
58 to 61	Float	T-EFS: elapsed time to reach position 14% (Open EFS) or position 86% (Close EFS)
62 to 65	Float	T-EFS: elapsed time to reach position 15% (Open EFS) or position 85% (Close EFS)
66 to 69	Float	T-EFS: elapsed time to reach position 16% (Open EFS) or position 84% (Close EFS)

**Table 194. Response Data Bytes (Transaction ID = 1)**

Byte	Format	Description
0	Unsigned Int-8	EFS Part1 Transaction ID = 1
1	Enum-8	EFS Curve ID (See Section 10.18)
2 to 5	Float	T-EFS: elapsed time to reach position 17% (Open EFS) or position 83% (Close EFS)
6 to 9	Float	T-EFS: elapsed time to reach position 18% (Open EFS) or position 82% (Close EFS)
10 to 13	Float	T-EFS: elapsed time to reach position 19% (Open EFS) or position 81% (Close EFS)
14 to 17	Float	T-EFS: elapsed time to reach position 20% (Open EFS) or position 80% (Close EFS)
18 to 21	Float	T-EFS: elapsed time to reach position 21% (Open EFS) or position 79% (Close EFS)
22 to 25	Float	T-EFS: elapsed time to reach position 22% (Open EFS) or position 78% (Close EFS)
26 to 29	Float	T-EFS: elapsed time to reach position 23% (Open EFS) or position 77% (Close EFS)
30 to 33	Float	T-EFS: elapsed time to reach position 24% (Open EFS) or position 76% (Close EFS)
34 to 37	Float	T-EFS: elapsed time to reach position 25% (Open EFS) or position 75% (Close EFS)
38 to 41	Float	T-EFS: elapsed time to reach position 26% (Open EFS) or position 74% (Close EFS)
42 to 45	Float	T-EFS: elapsed time to reach position 27% (Open EFS) or position 73% (Close EFS)
46 to 49	Float	T-EFS: elapsed time to reach position 28% (Open EFS) or position 72% (Close EFS)
50 to 53	Float	T-EFS: elapsed time to reach position 29% (Open EFS) or position 71% (Close EFS)
54 to 57	Float	T-EFS: elapsed time to reach position 30% (Open EFS) or position 70% (Close EFS)
58 to 61	Float	T-EFS: elapsed time to reach position 31% (Open EFS) or position 69% (Close EFS)
62 to 65	Float	T-EFS: elapsed time to reach position 32% (Open EFS) or position 68% (Close EFS)
66 to 69	Float	T-EFS: elapsed time to reach position 33% (Open EFS) or position 67% (Close EFS)

**Table 195. Response Data Bytes (Transaction ID = 2)**

Byte	Format	Description
0	Unsigned Int-8	EFS Part1 Transaction ID = 1
1	Enum-8	EFS Curve ID (See Section 10.18)
2 to 5	Float	T-EFS: elapsed time to reach position 34% (Open EFS) or position 66% (Close EFS)
6 to 9	Float	T-EFS: elapsed time to reach position 35% (Open EFS) or position 65% (Close EFS)
10 to 13	Float	T-EFS: elapsed time to reach position 36% (Open EFS) or position 64% (Close EFS)
14 to 17	Float	T-EFS: elapsed time to reach position 37% (Open EFS) or position 63% (Close EFS)
18 to 21	Float	T-EFS: elapsed time to reach position 38% (Open EFS) or position 62% (Close EFS)
22 to 25	Float	T-EFS: elapsed time to reach position 39% (Open EFS) or position 61% (Close EFS)
26 to 29	Float	T-EFS: elapsed time to reach position 40% (Open EFS) or position 60% (Close EFS)
30 to 33	Float	T-EFS: elapsed time to reach position 41% (Open EFS) or position 59% (Close EFS)
34 to 37	Float	T-EFS: elapsed time to reach position 42% (Open EFS) or position 58% (Close EFS)
38 to 41	Float	T-EFS: elapsed time to reach position 43% (Open EFS) or position 57% (Close EFS)
42 to 45	Float	T-EFS: elapsed time to reach position 44% (Open EFS) or position 56% (Close EFS)
46 to 49	Float	T-EFS: elapsed time to reach position 45% (Open EFS) or position 55% (Close EFS)
50 to 53	Float	T-EFS: elapsed time to reach position 46% (Open EFS) or position 54% (Close EFS)
54 to 57	Float	T-EFS: elapsed time to reach position 47% (Open EFS) or position 53% (Close EFS)
58 to 61	Float	T-EFS: elapsed time to reach position 48% (Open EFS) or position 52% (Close EFS)
62 to 65	Float	T-EFS: elapsed time to reach position 49% (Open EFS) or position 51% (Close EFS)
66 to 69	Float	T-EFS: elapsed time to reach position 50% (Open EFS) or position 50% (Close EFS)

**Table 196. Command-Specific Response Codes**

Code	Class	Description
0	Success	No Command-Specific Errors
1	-	Undefined
2	Error	Invalid Selection
3 to 4	-	Undefined
5	Error	Too Few Data Bytes Received
6 to 31	-	Undefined
32	Error	Busy
33 to 127	-	Undefined

## 8.3.26 Command #155: Read EFS Curve Part2

This command allows reading the last 51 samples of one EFS Curve.

**Table 197. Request Data Bytes**

Byte	Format	Description
0	Unsigned Int-8	EFS Part2 Transaction ID (0 to 2)
1	Enum-8	EFS Curve ID (See Section 10.18)

**Table 198. Response Data Bytes (Transaction ID = 0)**

Byte	Format	Description
0	Unsigned Int-8	EFS Part2 Transaction ID = 0
1	Enum-8	EFS Curve ID (See Section 10.18)
2 to 5	Float	T-EFS: elapsed time to reach position 51% (Open EFS) or position 49% (Close EFS)
6 to 9	Float	T-EFS: elapsed time to reach position 52% (Open EFS) or position 48% (Close EFS)
10 to 13	Float	T-EFS: elapsed time to reach position 53% (Open EFS) or position 47% (Close EFS)
14 to 17	Float	T-EFS: elapsed time to reach position 54% (Open EFS) or position 46% (Close EFS)
18 to 21	Float	T-EFS: elapsed time to reach position 55% (Open EFS) or position 45% (Close EFS)
22 to 25	Float	T-EFS: elapsed time to reach position 56% (Open EFS) or position 44% (Close EFS)
26 to 29	Float	T-EFS: elapsed time to reach position 57% (Open EFS) or position 43% (Close EFS)
30 to 33	Float	T-EFS: elapsed time to reach position 58% (Open EFS) or position 42% (Close EFS)
34 to 37	Float	T-EFS: elapsed time to reach position 59% (Open EFS) or position 41% (Close EFS)
38 to 41	Float	T-EFS: elapsed time to reach position 60% (Open EFS) or position 40% (Close EFS)
42 to 45	Float	T-EFS: elapsed time to reach position 61% (Open EFS) or position 39% (Close EFS)
46 to 49	Float	T-EFS: elapsed time to reach position 62% (Open EFS) or position 38% (Close EFS)
50 to 53	Float	T-EFS: elapsed time to reach position 63% (Open EFS) or position 37% (Close EFS)
54 to 57	Float	T-EFS: elapsed time to reach position 64% (Open EFS) or position 36% (Close EFS)
58 to 61	Float	T-EFS: elapsed time to reach position 65% (Open EFS) or position 35% (Close EFS)
62 to 65	Float	T-EFS: elapsed time to reach position 66% (Open EFS) or position 34% (Close EFS)
66 to 69	Float	T-EFS: elapsed time to reach position 67% (Open EFS) or position 33% (Close EFS)

**Table 199. Response Data Bytes (Transaction ID = 1)**

Byte	Format	Description
0	Unsigned Int-8	EFS Part2 Transaction ID = 1
1	Enum-8	EFS Curve ID (See Section 10.18)
2 to 5	Float	T-EFS: elapsed time to reach position 68% (Open EFS) or position 32% (Close EFS)
6 to 9	Float	T-EFS: elapsed time to reach position 69% (Open EFS) or position 31% (Close EFS)
10 to 13	Float	T-EFS: elapsed time to reach position 70% (Open EFS) or position 30% (Close EFS)
14 to 17	Float	T-EFS: elapsed time to reach position 71% (Open EFS) or position 29% (Close EFS)
18 to 21	Float	T-EFS: elapsed time to reach position 72% (Open EFS) or position 28% (Close EFS)
22 to 25	Float	T-EFS: elapsed time to reach position 73% (Open EFS) or position 27% (Close EFS)
26 to 29	Float	T-EFS: elapsed time to reach position 74% (Open EFS) or position 26% (Close EFS)
30 to 33	Float	T-EFS: elapsed time to reach position 75% (Open EFS) or position 25% (Close EFS)
34 to 37	Float	T-EFS: elapsed time to reach position 76% (Open EFS) or position 24% (Close EFS)
38 to 41	Float	T-EFS: elapsed time to reach position 77% (Open EFS) or position 23% (Close EFS)
42 to 45	Float	T-EFS: elapsed time to reach position 78% (Open EFS) or position 22% (Close EFS)
46 to 49	Float	T-EFS: elapsed time to reach position 79% (Open EFS) or position 21% (Close EFS)
50 to 53	Float	T-EFS: elapsed time to reach position 80% (Open EFS) or position 20% (Close EFS)
54 to 57	Float	T-EFS: elapsed time to reach position 81% (Open EFS) or position 19% (Close EFS)
58 to 61	Float	T-EFS: elapsed time to reach position 82% (Open EFS) or position 18% (Close EFS)
62 to 65	Float	T-EFS: elapsed time to reach position 83% (Open EFS) or position 17% (Close EFS)
66 to 69	Float	T-EFS: elapsed time to reach position 84% (Open EFS) or position 16% (Close EFS)

**Table 200. Response Data Bytes (Transaction ID = 2)**

Byte	Format	Description
0	Unsigned Int-8	EFS Part1 Transaction ID = 2
1	Enum-8	EFS Curve ID (See Section 10.18)
2 to 5	Float	T-EFS: elapsed time to reach position 85% (Open EFS) or position 15% (Close EFS)
6 to 9	Float	T-EFS: elapsed time to reach position 86% (Open EFS) or position 14% (Close EFS)
10 to 13	Float	T-EFS: elapsed time to reach position 87% (Open EFS) or position 13% (Close EFS)
14 to 17	Float	T-EFS: elapsed time to reach position 88% (Open EFS) or position 12% (Close EFS)
18 to 21	Float	T-EFS: elapsed time to reach position 89% (Open EFS) or position 11% (Close EFS)
22 to 25	Float	T-EFS: elapsed time to reach position 90% (Open EFS) or position 10% (Close EFS)
26 to 29	Float	T-EFS: elapsed time to reach position 91% (Open EFS) or position 9% (Close EFS)
30 to 33	Float	T-EFS: elapsed time to reach position 92% (Open EFS) or position 8% (Close EFS)
34 to 37	Float	T-EFS: elapsed time to reach position 93% (Open EFS) or position 7% (Close EFS)
38 to 41	Float	T-EFS: elapsed time to reach position 94% (Open EFS) or position 6% (Close EFS)
42 to 45	Float	T-EFS: elapsed time to reach position 95% (Open EFS) or position 5% (Close EFS)
46 to 49	Float	T-EFS: elapsed time to reach position 96% (Open EFS) or position 4% (Close EFS)
50 to 53	Float	T-EFS: elapsed time to reach position 97% (Open EFS) or position 3% (Close EFS)
54 to 57	Float	T-EFS: elapsed time to reach position 98% (Open EFS) or position 2% (Close EFS)
58 to 61	Float	T-EFS: elapsed time to reach position 99% (Open EFS) or position 1% (Close EFS)
62 to 65	Float	T-EFS: elapsed time to reach position 100% (Open EFS) or position 0% (Close EFS)
66 to 69	Float	Not Used

**Table 201. Command-Specific Response Codes**

Code	Class	Description
0	Success	No Command-Specific Errors
1	-	Undefined
2	Error	Invalid Selection
3 to 4	-	Undefined
5	Error	Too Few Data Bytes Received
6 to 31	-	Undefined
32	Error	Busy
33 to 127	-	Undefined

### 8.3.27 Command #156: Read Event Log Data Header

This command allows reading the header data of the Event Log.

**Table 202. Request Data Bytes**

Byte	Format	Description
None	-	-

**Table 203. Response Data Bytes**

Byte	Format	Description
0 to 1	Unsigned Int-16	Number of Events stored
2 to 4	Date	Recording Start Date
5 to 8	Time	Recording Start Time
9	Enum-8	Memory Mode (See Section 10.19)

**Table 204. Command-Specific Response Codes**

Byte	Format	Description
0	Success	No Command-Specific Errors
1	-	Undefined
2	Error	Invalid Selection
3 to 4	-	Undefined
5	Error	Too Few Data Bytes Received
6 to 31	-	Undefined
32	Error	Busy
33 to 127	-	Undefined

## 8.3.28 Command #157: Read Event Log

This command allows reading one of the events stored in the Event Log.

**Table 205. Request Data Bytes**

Byte	Format	Description
0 to 1	Unsigned Int-16	Event Number (See Section 10.20)

**Table 206. Response Data Bytes**

Byte	Format	Description
0 to 1	Unsigned Int-16	Event Number (See Section 10.20)
2 to 4	Date	Event Date
5 to 8	Time	Event Time
9	Enum-8	Event Code (See Section 10.21)
10	Enum-8	Event Source (See Section 10.25)
11 to 12	Unsigned Int-16	Reserved – Not Used

**Table 207. Command-Specific Response Codes**

Code	Class	Description
0	Success	No Command-Specific Errors
1	-	Undefined
2	Error	Invalid Selection
3 to 4	-	Undefined
5	Error	Too Few Data Bytes Received
6 to 31	-	Undefined
32	Error	Busy
33 to 127	-	Undefined

If Event Number is greater than the Number of Events stored (Command 156, Response Data Bytes 0 to 1), the device returns the following values:

- Event Date: 6th February 2136
- Event Time: 06:28:15
- Event Code: 255
- Event Source: 255

## 8.3.29 Command #158: Read Recorder Log Data Header

This command allows reading the header data of the Recorder Log.

**Table 208. Request Data Bytes**

Byte	Format	Description
None	-	-

**Table 209. Response Data Bytes**

Byte	Format	Description
0 to 1	Unsigned Int-16	Number of Recorders stored
2 to 4	Date	Recording Start Date
5 to 8	Time	Recording Start Time
9	Enum-8	Memory Mode (See Section 10.19)
10 to 11	Unsigned Int-16	Sample Interval (seconds)

**Table 210. Command-Specific Response Codes**

Code	Class	Description
0	Success	No Command-Specific Errors
1	-	Undefined
2	Error	Invalid Selection
3 to 4	-	Undefined
5	Error	Too Few Data Bytes Received
6 to 31	-	Undefined
32	Error	Busy
33 to 127	-	Undefined

### 8.3.30 Command #159: Read Recorder Log

This command allows reading one of the Recorders stored in the Recorder Log.

**Table 211. Request Data Bytes**

Byte	Format	Description
0 to 1	Unsigned Int-16	Recorder Number (See Section 10.22)

**Table 212. Response Data Bytes**

Byte	Format	Description
0 to 1	Unsigned Int-16	Recorder Number (See Section 10.22)
2 to 4	Date	Recorder Date
5 to 8	Time	Recorder Time
9	Signed Int-8	Recorder Data – Electronic Temperature (°C)
10	Signed Int-8	Recorder Data – Motor Temperature (°C)
11 to 12	Unsigned Int-16	Recorder Data – Voltage (V)
13 to 14	Unsigned Int-16	Reserved – Not Used

**Table 213. Command-Specific Response Codes**

Code	Class	Description
0	Success	No Command-Specific Errors
1	-	Undefined
2	Error	Invalid Selection
3 to 4	-	Undefined
5	Error	Too Few Data Bytes Received
6 to 31	-	Undefined
32	Error	Busy
33 to 127	-	Undefined

If Recorder Number is greater than the Number of Recorders stored (Command 158, Response Data Bytes 0 to 1), the device returns the following values:

- Recorder Date: 6th February 2136
- Recorder Time: 06:28:15
- Recorder Data – Electronic Temperature (°C): -1
- Recorder Data – Motor Temperature (°C): -1
- Recorder Data – Voltage (V): 65535

### 8.3.31 Command #160: Read T-Recorder Log Data Header

This command allows reading the header data of the T-Recorder Log.

**Table 214. Request Data Bytes**

Byte	Format	Description
None	-	-

**Table 215. Response Data Bytes**

Byte	Format	Description
0 to 1	Unsigned Int-16	Number of T-Recorders stored
2 to 4	Date	Recording Start Date
5 to 8	Time	Recording Start Time
9	Enum-8	Memory Mode (See Section 10.19)
10 to 11	Unsigned Int-16	Sample Interval (seconds)

**Table 216. Command-Specific Response Codes**

Code	Class	Description
0	Success	No Command-Specific Errors
1	-	Undefined
2	Error	Invalid Selection
3 to 4	-	Undefined
5	Error	Too Few Data Bytes Received
6 to 31	-	Undefined
32	Error	Busy
33 to 127	-	Undefined

### 8.3.32 Command #161: Read T-Recorder Log

This command allows reading one of the T-Recorders stored in the T-Recorder Log.

**Table 217. Request Data Bytes**

Byte	Format	Description
0 to 1	Unsigned Int-16	T-Recorder Number (See Section 10.23)

**Table 218. Response Data Bytes**

Byte	Format	Description
0 to 1	Unsigned Int-16	T-Recorder Number (See Section 10.23)
2 to 4	Date	T-Recorder Date
5 to 8	Time	T-Recorder Time
9	Signed Int-8	T-Recorder Data – Electronic Temperature (°C)
10	Signed Int-8	T-Recorder Data – Motor Temperature (°C)
11 to 12	Unsigned Int-16	T-Recorder Data – Voltage (V)
13 to 14	Unsigned Int-16	Reserved – Not Used

**Table 219. Command-Specific Response Codes**

Code	Class	Description
0	Success	No Command-Specific Errors
1	-	Undefined
2	Error	Invalid Selection
3 to 4	-	Undefined
5	Error	Too Few Data Bytes Received
6 to 31	-	Undefined
32	Error	Busy
33 to 127	-	Undefined

If T-Recorder Number is greater than the Number of T-Recorders stored (Command 160, Response Data Bytes 0 to 1), the device returns the following values:

- T-Recorder Date: 6th February 2136
- T-Recorder Time: 06:28:15
- T-Recorder Data – Electronic Temperature (°C): -1
- T-Recorder Data – Motor Temperature (°C): -1
- T-Recorder Data – Voltage (V): 65535

### 8.3.33 Command #162: Read Card Report

This command allows reading the Card Report of one electronic card.

**Table 220. Request Data Bytes**

Byte	Format	Description
0	Enum-8	Card ID (See Section 10.24)

**Table 221. Response Data Bytes**

Byte	Format	Description
0	Enum-8	Card ID (See Section 10.24)
1 to 10	ASCII	Card Code
11 to 12	ASCII	Not Used
13 to 14	ASCII	Production Week
15 to 16	ASCII	Production Year
17 to 22	ASCII	Serial Number
23 to 27	ASCII	Hardware Revision
28 to 32	ASCII	Firmware Revision
33 to 64	ASCII	Free Text

**Table 222. Command-Specific Response Codes**

Code	Class	Description
0	Success	No Command-Specific Errors
1	-	Undefined
2	Error	Invalid Selection
3 to 4	-	Undefined
5	Error	Too Few Data Bytes Received
6 to 31	-	Undefined
32	Error	Busy
33 to 127	-	Undefined

## 8.3.34 Command #163: Write Card Report

This command allows forcing the Card Report of one electronic card.

**Table 223. Request Data Bytes**

Byte	Format	Description
0	Enum-8	Card ID (See Section 10.24)
1 to 10	ASCII	Card Code
11 to 12	ASCII	Not Used
13 to 14	ASCII	Production Week
15 to 16	ASCII	Production Year
17 to 22	ASCII	Serial Number
23 to 27	ASCII	Hardware Revision
28 to 32	ASCII	Firmware Revision
33 to 64	ASCII	Free Text

**Table 224. Response Data Bytes**

Byte	Format	Description
0	Enum-8	Card ID (See Section 10.24)
1 to 10	ASCII	Card Code
11 to 12	ASCII	Not Used
13 to 14	ASCII	Production Week
15 to 16	ASCII	Production Year
17 to 22	ASCII	Serial Number
23 to 27	ASCII	Hardware Revision
28 to 32	ASCII	Firmware Revision
33 to 64	ASCII	Free Text

**Table 225. Command-Specific Response Codes**

Code	Class	Description
0	Success	No Command-Specific Errors
1	-	Undefined
2	Error	Invalid Selection
3 to 4	-	Undefined
5	Error	Too Few Data Bytes Received
6	-	Undefined
7	Error	In Write Protect Mode
8 to 31	-	Undefined
32	Error	Busy
33 to 127	-	Undefined

If a master tries to write a Cart Report without the user level permissions, response code 7 ("In Write Protect Mode") is returned. The modification of the value of the parameters is restricted by the permissions of the user level logged, see Appendix B for details.

### 8.3.35 Command #164: Read Alarms, Warnings and Connection Logs Data Header

This command allows reading the number of Alarms, Warnings, and Connections stored in the Alarms Log, in the Warnings Log and in the Connections Log, respectively.

**Table 226. Request Data Bytes**

Byte	Format	Description
None	-	-

**Table 227. Response Data Bytes**

Byte	Format	Description
0 to 1	Unsigned Int-16	Number of Alarms stored in the Alarms Log
2 to 3	Unsigned Int-16	Number of Warnings stored in the Warnings Log
4 to 5	Unsigned Int-16	Number of Connections stored in the Connections Log

**Table 228. Command-Specific Response Codes**

Code	Class	Description
0	Success	No Command-Specific Errors
1	-	Undefined
2	Error	Invalid Selection
3 to 4	-	Undefined
5	Error	Too Few Data Bytes Received
6 to 31	-	Undefined
32	Error	Busy
33 to 127	-	Undefined

### 8.3.36 Command #165: Read Alarms Log

This command allows reading one of the Alarms stored in the Alarms Log.

**Table 229. Request Data Bytes**

Byte	Format	Description
0 to 1	Unsigned Int-16	Alarm Number (See Section 10.26)

**Table 230. Response Data Bytes**

Byte	Format	Description
0 to 1	Unsigned Int-16	Alarm Number (See Section 10.26)
2 to 4	Date	Alarm Date
5 to 8	Time	Alarm Time
9	Enum-8	Alarm Code (See Section 10.28)

**Table 231. Command-Specific Response Codes**

Code	Class	Description
0	Success	No Command-Specific Errors
1	-	Undefined
2	Error	Invalid Selection
3 to 4	-	Undefined
5	Error	Too Few Data Bytes Received
6 to 31	-	Undefined
32	Error	Busy
33 to 127	-	Undefined

If "Alarm Number" is greater than the "Alarms stored" (Command 164, Response Data Bytes 0 to 1), the device returns the following values:

- Date: 6th February 2136
- Time: 06:28:15
- Alarm Code: 255

## 8.3.37 Command #166: Read Warnings Log

This command allows reading one of the Warnings stored in the Warnings Log.

**Table 232. Request Data Bytes**

Byte	Format	Description
0 to 1	Unsigned Int-16	Warning Number (See Section 10.27)

**Table 233. Response Data Bytes**

Byte	Format	Description
0 to 1	Unsigned Int-16	Warning Number (See Section 10.27)
2 to 4	Date	Warning Date
5 to 8	Time	Warning Time
9	Enum-8	Warning Code (See Section 10.29)

**Table 234. Command-Specific Response Codes**

Code	Class	Description
0	Success	No Command-Specific Errors
1	-	Undefined
2	Error	Invalid Selection
3 to 4	-	Undefined
5	Error	Too Few Data Bytes Received
6 to 31	-	Undefined
32	Error	Busy
33 to 127	-	Undefined

If “Warning Number” is greater than the “Warnings stored” (Command 164, Response Data Bytes 2 to 3), the device returns the following values:

- Date: 6th February 2136
- Time: 06:28:15
- Alarm Code: 255

## 8.3.38 Command #167: Read Connections Log

This command allows reading one of the Connections stored in the Connections Log.

**Table 235. Request Data Bytes**

Byte	Format	Description
0	Unsigned Int-8	Connection Log Transaction ID (0 to 1)
1 to 2	Unsigned Int-16	Connection Number (See Section 10.30)

**Table 236. Response Data Bytes (Connection Log Transaction ID = 0)**

Byte	Format	Description
0	Unsigned Int-8	Connection Log Transaction ID = 0
1 to 2	Unsigned Int-16	Connection Number (See Section 10.30)
3	Enum-8	Password Level (See Section 10.31)
4 to 51	ASCII	PC/PDA ID

**Table 237. Response Data Bytes (Connection Log Transaction ID = 1)**

Code	Class	Description
0	Unsigned Int-8	Connection Log Transaction ID = 1
1 to 2	Unsigned Int-16	Connection Number (See Section 10.30)
3 to 26	ASCII	Operator ID
27 to 34	Unsigned Int-8	Reserved – Not Used
35	Enum-8	Connection Type (See Section 10.32)
36 to 38	Date	Connection Date
39 to 42	Time	Connection Time

**Table 238. Command-Specific Response Codes**

Code	Class	Description
0	Success	No Command-Specific Errors
1	-	Undefined
2	Error	Invalid Selection
3 to 4	-	Undefined
5	Error	Too Few Data Bytes Received
6 to 31	-	Undefined
32	Error	Busy
33 to 127	-	Undefined

If “Connection Number” is greater than the “Connections stored” (Command 164, Response Data Bytes 4 to 5), the device returns the following values:

- Password Level: 255
- PC/PDA ID: 0xFF (48 times)
- Operator ID: 255
- Reserved – Not Used: 0xFF (8 times)
- Connection Type: 255
- Connection Date: 6th February 2136
- Connection Time: 06:28:15

### 8.3.39 Command 168: Read Actuator Commands

This command allows reading the status of the commands sent from HART.

**Table 239. Request Data Bytes**

Byte	Format	Description
None	-	-

**Table 240. Request Data Bytes**

Byte	Format	Description
0 to 1	Bit Enumerated	Actuator Commands (see Section 10.31)
2 to 5	Float	Position Request

**Table 241. Command-Specific Response Codes**

Code	Class	Description
0	Success	No Command-Specific Errors
1 to 31	-	Undefined
32	Error	Device Busy
33 to 127	-	Undefined

Position Request can assume values from 0,0% to 100,0%. If LOOP CURRENT MODE is DISABLED and "Enable Positioner" (Actuator Commands, bit 4) is active, "Position Request" can be used to drive the actuator to the desired position.

### 8.3.40 Command 169: Write Actuator Commands

This command allows sending commands to the device.

**Table 242. Request Data Bytes**

Byte	Format	Description
0 to 1	Bit Enumerated	Actuator Commands (see Section 10.31)
2 to 5	Float	Position Request

**Table 243. Request Data Bytes**

Byte	Format	Description
0 to 1	Bit Enumerated	Actuator Commands (see Section 10.31)
2 to 5	Float	Position Request

**Table 244. Command-Specific Response Codes**

Code	Class	Description
0	Success	No Command-Specific Errors
1 to 4	-	Undefined
5	Error	Too few data bytes received
6	Error	Illegal Value
7 to 31	-	Undefined
32	Error	Device Busy
33 to 127	-	Undefined

Position Request can assume values from 0,0% to 100,0%. If LOOP CURRENT MODE is DISABLED and "Enable Positioner" (Actuator Commands, bit 4) is active, "Position Request" can be used to drive the actuator to the desired position.

### 8.3.41 Command 171: Read Actuator Status

This command allows reading the status of the actuator.

**Table 245. Request Data Bytes**

Byte	Format	Description
None	-	-

**Table 246. Request Data Bytes**

Byte	Format	Description
0	Bit Enumerated	Actuator Status 1 (see Section 10.34 for details)
1	Bit Enumerated	Actuator Status 2 (see Section 10.35 for details)
2	Bit Enumerated	Actuator Status 3 (see Section 10.36 for details)
3	Bit Enumerated	Actuator Status 4 (see Section 10.37 for details)
4	Bit Enumerated	Actuator Status 5 (see Section 10.38 for details)
5	Bit Enumerated	Actuator Status 6 (see Section 10.39 for details)
6	Bit Enumerated	Heater Status (see 10.40 for details)
7	Bit Enumerated	Digital Inputs Status (see Section 10.41 for details)
8	Bit Enumerated	Output Contacts Status 1 (see Section 10.42 for details)
9	Bit Enumerated	Output Contacts Status 2 (see Section 10.43 for details)
10	Enumerated	DIN Status (see Section 10.44 for details)
11	Enumerated	K1 Contactor Status (see Section 10.45 for details)
12	Enumerated	K2 Contactor Status (see Section 10.46 for details)
13	Enumerated	Motor Thermostat Status (see Section 10.47 for details)
14	Bit Enumerated	HART Interface Status (See Section 10.48 for details)
15	Bit Enumerated	Alarms 1 (See Section 10.49 for details)
16	Bit Enumerated	Alarms 2 (See Section 10.50 for details)
17	Bit Enumerated	Alarms 3 (See Section 10.51 for details)
18	Bit Enumerated	Alarms 4 (See Section 10.52 for details)
19	Bit Enumerated	Warnings 1 (See Section 10.53 for details)
20	Bit Enumerated	Warnings 2 (See Section 10.54 for details)
21 to 24	Unsigned Int-16	Encoder Absolute Position
25	Bit Enumerated	Encoder Status 1 (See Section 10.55 for details)
26	Bit Enumerated	Encoder Status 2 (See Section 10.56 for details)
27 to 28	Unsigned Int-16	Encoder Wheel 1
29 to 30	Unsigned Int-16	Encoder Wheel 2
31 to 32	Unsigned Int-16	Encoder Wheel 3
33 to 34	Unsigned Int-16	Encoder Communication Errors
35 to 36	Unsigned Int-16	Bus Communication Errors
37 to 38	Unsigned Int-16	Terminal Board Errors
39 to 40	Unsigned Int-16	Torque Potentiometer
41 to 44	Float	Battery Voltage
45	Enumerated	User Level Logged (See Section 10.57 for details)

**Table 247. Command-Specific Response Codes**

Code	Class	Description
0	Success	No Command-Specific Error
1 to 31	-	Undefined
32	Error	Device Busy
33 to 127	-	Undefined

“Encoder Absolute Position” can assume values from 0 to 2196479. “Encoder Wheel 1”, “Encoder Wheel 2”, and “Encoder Wheel 3” can assume values from 0 to 2047.

“Encoder Communication Errors”, “Bus Communication Errors”, and “Terminal Board Errors” can assume values from 0 to 65535.

“Torque Potentiometer” can assume values from 0 to 4095.

“Battery Voltage” can assume values from 0 to 15.9. Engineering Unit is Volts.

### 8.3.42 Command 172: Read PST Status

This command allows reading the status of the last PST command executed.

**Table 248. Request Data Bytes**

Byte	Format	Description
None	-	-

**Table 249. Request Data Bytes**

Byte	Format	Description
0	Unsigned Int-8	PST Progress Counter (Eng. Unit: Percent)
1	Bit Enumerated	Last PST Status (see 10.58 for details)
2	Bit Enumerated	Last PST Reset Conditions 1 (see 10.59 for details)
3	Bit Enumerated	Last PST Reset Conditions 2 (see 10.60 for details)
4	Bit Enumerated	Last PST Reset Conditions 3 (see 10.61 for details)

**Table 250. Command-Specific Response Codes**

Code	Class	Description
0	Success	No Command-Specific Error
1 to 31	-	Undefined
32	Error	Device Busy
33 to 127	-	Undefined

## 8.4 Common Tables

**Table 251. Expanded Device Type Codes**

Expanded Device Code (Hex)	Description	Company Name
B77E	HRT2000v4	Biffi
B705	HRTIMVS2000	Biffi
B77F	EleHRT-24	Biffi

**NOTE:**

Other manufacturer devices are not listed.

**Table 252. Engineering Unit Codes**

Code	Description
32	Degrees Celsius
38	Hertz
39	Milliamperes
51	Seconds
57	Percent
58	Volts
251	None

**NOTE:**

Only Unit Codes used by EleHRT-24 are listed.

**Table 253. Transfer Function Codes**

Code	Transfer Function Description
0	Linear
1	Square Root
2	Square Root Third Power
3	Square Root Fifth Power
4	Special Curve
5	Square
230	Discrete (Switch)
231	Square Root Plus Special Care
232	Square Root Third Power Plus Special Curve
233	Square Root Fifth Power Plus Special Curve
240 to 250	Not Used
251	None
252	Unknown
253	Special

**Table 254. Alarm Selection Codes**

Code	Alarm Selection Description
0	High
1	Low
239	Hold Last Output Value
240 to 250	Not Used
251	None
252	Unknown
253	Special

**Table 255. Write Protect Codes**

Code	Physical Signal Definition
0	No – No Write Protected
1	Yes – Write Protected
250	Not used
251	None
252	Unknown
253	Special
253	Special

**Table 256. Manufacturer Identification Codes**

Code (Dec)	Code (Hex)	Company Name
183	00B7	Biffi

**NOTE:**

Other manufacturers are not listed.

**Table 257. Burst Mode Control Codes**

Code	Burst Mode Control Definition
0	Off
1	Enable Burst on Token-Passing Data Link Layer only
2	Enable Burst on TDMA Data-Link Layer only
3	Enable Burst on TDMA and Token-Passing Data Link Layers
250	Reserved
251	Reserved
252	Reserved
253	Reserved

**NOTE:**

Only codes 0 and 1 are supported by EleHRT-24 field device.

**Table 258. Physical Signalling Codes**

Code	Physical Signal Definition
0	Bell 202 current
1	Bell 202 voltage
2	RS-485
3	RS-232
4	Wireless
6	Special

**Table 259. Flag Assignments**

Code	Flag Assignment Definition
00	Undefined
01	Multi-Sensor Field Device
02	Eeprom Control
04	Protocol Bridge Device
08	IEEE 802.15.4 2.4GHz DSS with O-QPSK Modulation
10 to 20	Undefined
40	C8psk Capable Field Device
80	C8psk In Multidrop Only

**Table 260. Loop Current Mode Codes**

Code	Loop Current Mode Description
0	Disabled
1	Enabled

**Table 261. Extended Device Status Codes**

Code	Description
00	Undefined
01	<b>Maintenance Required:</b> This bit is set to indicated that, while the device has not malfunctioned, the Field Device requires maintenance.
02	<b>Device Variable Alert:</b> This bit is set if any Device Variable is in Alarm or Warning State. The host should identify the Device Variable(s) causing this to be set using the Device Variable Status indicators.
04	<b>Critical Power Failure:</b> For devices that can operate from stored power. This bit is set when that power is becoming critically low.
08 to 80	Undefined

**Table 262. Device Variable Family Codes**

Code	Device Variable Family
0 to 3	Reserved
4	Temperature
5	Pressure
6	Valve/Actuator
7	Simple PID Control
8	pH
9	Conductivity
10	Totalizer
11	Level
12	Vortex Flow
13	Mag Flow
14	Coriolis Flow
132 to 249	Reserved
250	Not Used

**Table 263. Device Variable Classification Codes**

Code	Device Variable Classification
0	Device Variable Not Classified
1 to 63	Reserved
64	Temperature
70	Time
80	Frequency
83	EMF (Electromagnetic Unit of Electric Potential)
91	Valve Actuator

**NOTE:**

Only Classification Codes used by EleHRT-24 are listed.

**Table 264. Analog Channel Flags**

Code	Flag Definition
0x01	This Analog Channel is a Field Device analog input channel. In other words, the Field Device has an ADC connected to this channel when this bit is set.

**Table 265. Burst Message Trigger Modes**

Code	Burst Message Trigger Mode Description
0	<b>Continuous:</b> The burst message is published continuously at (worst case) the minimum update period.
1	<b>Window:</b> The burst message is triggered when the source value deviates more than the specified trigger value.
2	<b>Rising:</b> The burst message is triggered when source value rises above the specified trigger value.
3	<b>Falling:</b> The burst message is triggered when the source value falls below the specified trigger value.
4	<b>On-Change:</b> The burst message is triggered when any value in the message changes.

**Table 266. Device Profile Code**

Code	Device Profile Code Description
1	HART Process Automation Device
2	HART Discrete Device
3	Hybrid: Process Automation + Discrete
4	I/O System
129	WirelessHART Process Automation Device
130	WirelessHART Discrete Device
131	WirelessHART Hybrid: Process Automation + Discrete
132	WirelessHART Gateway
141	WirelessHART Process Adapter
142	WirelessHART Discrete Adapter
144	WirelessHART-Enable Handheld/Portable Maintenance Tool

# Section 9: Device Variables

## 9.1 List of Device Variables

**Table 267. Device Variables on EleHRT-24**

Device Variable	Description	Classification	Unit Code	R/W	Minimum	Maximum	Type
0	Analog Position Request	Not Classified	Percent	R	-25	125	FLOAT
1	Actuator Position	Not Classified	Percent	R	0	100	FLOAT
2	Torque	Not Classified	Percent	R	-127	128	FLOAT
3	Temperature	Temperature	Celsius	R	-127	128	FLOAT
4	Motor Speed	Velocity	rpm	R	0	4000	FLOAT
5	Main Voltage	EMF	Volts	R	0	1000	FLOAT
6	Current	Current	A	R	0	120	FLOAT
7	Motor Temperature	Temperature	Celsius	R	-40	150	FLOAT
8	Terminal Board Temperature	Temperature	Celsius	R	-55	125	FLOAT
9	Position Request (used by Logic Card)	Not Classified	Percent	R	-30	130	FLOAT
10	Auxiliary Analog Input (mA)	Current	mA	R	0	30	FLOAT
11	Auxiliary Analog Input(bit)	Not Classified	Percent	R	0	4095	FLOAT
12	Analog Output (mA)	Current	mA	R	0	30	FLOAT
13	Analog Output (bit)	Not Classified	Percent	R	0	4095	FLOAT
14	Local Mode	Not Classified	Percent	R	0	1	FLOAT
15	Off Mode	Not Classified	Percent	R	0	1	FLOAT
16	Remote Mode	Not Classified	Percent	R	0	1	FLOAT
17	Stall Alarm	Not Classified	Percent	R	0	1	FLOAT
18	Device Alarm Active	Not Classified	Percent	R	0	1	FLOAT
19	Actuator Ready	Not Classified	Percent	R	0	1	FLOAT
20	Open Limit	Not Classified	Percent	R	0	1	FLOAT
21	Close Limit	Not Classified	Percent	R	0	1	FLOAT
22	Opening	Not Classified	Percent	R	0	1	FLOAT
23	Closing	Not Classified	Percent	R	0	1	FLOAT
24	Stopped	Not Classified	Percent	R	0	1	FLOAT
244	Percent Range	Not Classified	Percent	R	-	-	FLOAT
245	Loop Current	Not Classified	mA	R	-	-	FLOAT
246	PV *	-	-	R	-	-	FLOAT
247	SV *	-	-	R	-	-	FLOAT
248	TV *	-	-	R	-	-	FLOAT
249	QV *	-	-	R	-	-	FLOAT

**NOTES:**

- \* It depends on field device settings with Command #51, see Section 8.2.3 for details.
- PV is Analog Position Request (Device Variable 0).
- Default SV is Actuator Position (Device Variable 1).
- Default TV is Torque (Device Variable 2).
- Default QV is Temperature (Device Variable 3).

## 9.2 Device Variable Status Byte

All cyclical process data include a Device Variable Status byte.

The most significant two bits (bits 7 and 6) of every Device Variable Status byte return the overall status of the Device or Dynamic Variable value. The next two bits (bits 5 and 4) indicates whether the Device Variable value is limited. These four bits provide useful status about the Device Variable's value. The content of the lower 4 bits depend on the Device Variable Family. Each Device Family can have its own Device Family-specific Status defining the least significant bits. If set bit 3 indicates the additional Device Family-specific status is available via the appropriate Device Family Command.

**Figure 9. Device Variable Status Byte**

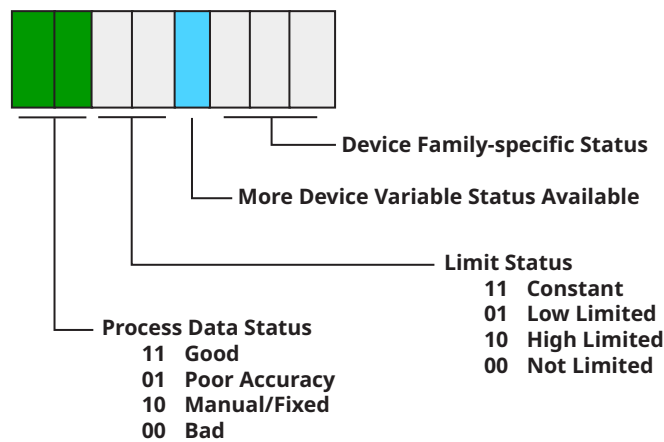

EleHRT-24 does not provide Device Family-specific Status for Dynamic and Device Variables, therefore last 4 bits are always set to 0.

## 9.3 Device Variables

### 9.3.1 Device Variable 0: Analog Position Request

This variable indicates the percentage corresponding to the Loop Current Signal.

### 9.3.2 Device Variable 1: Actuator Position

This variable indicates the current position of the actuator.

### 9.3.3 Device Variable 2: Torque

This variable indicates the current torque measured by the actuator.

### 9.3.4 Device Variable 3: Temperature

This variable indicates the internal temperature of the actuator.

### 9.3.5 Device Variable 4: Motor Speed

This variable indicates the speed of the motor.

### 9.3.6 Device Variable 5: Main Voltage

This variable indicates the power supply voltage measured by the actuator.

### 9.3.7 Device Variable 6: Current

This variable indicates the current measured by the actuator.

### 9.3.8 Device Variable 7: Motor Temperature

This variable indicates the temperature of the motor.

### 9.3.9 Device Variable 8: Terminal Board Temperature

This variable indicates the temperature of the terminal board.

### 9.3.10 Device Variable 9: Position Request (used by Logic Card)

This variable indicates the position request used by the logic card.

### 9.3.11 Device Variable 10: Auxiliary Analog Input (mA)

This variable indicates the analog input current measured on terminals B8-B9.

### 9.3.12 Device Variable 11: Auxiliary Analog Input (bit)

This variable indicates the digital value of the analog input signal applied to terminals B8-B9.

### 9.3.13 Device Variable 12: Analog Output (mA)

This variable indicates the Analog Output signal (expressed in mA) generated by the actuator.

### 9.3.14 Device Variable 13: Analog Output (bit)

This variable indicates the Analog Output signal (expressed in bit) generated by the actuator.

### 9.3.15 Device Variable 14: Local Mode

This variable indicates if the Local Selector Position is LOCAL (1) or not (0).

### 9.3.16 Device Variable 15: Off Mode

This variable indicates if the Local Selector Position is OFF (1) or not (0).

### 9.3.17 Device Variable 16: Remote Mode

This variable indicates if the Local Selector Position is REMOTE (1) or not (0).

### 9.3.18 Device Variable 17: Stall Alarm

This variable indicates if the Actuator Stall Alarm is active (1) or not (0). The Actuator Stall Alarm is active if at least one of these alarms is active:

- Jammed in Opening
- Jammed in Closing
- Hi-Hi Torque in Opening
- Hi-Hi Torque in Closing
- Mid Travel in Opening
- Mid Travel in Closing

### 9.3.19 Device Variable 18: Device Alarm Active

This variable indicates if at least an alarm is active (1) or not (0).

### 9.3.20 Device Variable 19: Actuator Ready

This variable indicates if the actuator is ready (1) or not ready (0) to be driven by remote controls.

### 9.3.21 Device Variable 20: Open Limit

This variable indicates if the actuator is fully open (1) or not (0).

### 9.3.22 Device Variable 21: Close Limit

This variable indicates if the actuator is fully closed (1) or not (0).

### 9.3.23 Device Variable 22: Opening

This variable indicates if the actuator is running in open direction (1) or not (0).

### 9.3.24 Device Variable 23: Closing

This variable indicates if the actuator is running in close direction (1) or not (0).

### 9.3.25 Device Variable 24: Stopped

This variable indicates if the actuator is stopped (1) or is running in close or opening direction (0).

### 9.3.26 Device Variable 244: Percent Range

This variable indicates the percentage corresponding to the Loop Current signal.

### 9.3.27 Device Variable 245: Loop Current

This variable indicates the percentage corresponding to the Loop Current signal.

### 9.3.28 Device Variable 246: Primary Variable

This variable indicates the PV, it assumes the value of Device Variable 0.

### 9.3.29 Device Variable 247: Secondary Variable

This variable indicates the SV. The default SV is the Device Variable 1 "Actuator Position". To select the Secondary Variable, see Section 8.2.3.

### 9.3.30 Device Variable 248: Tertiary Variable

This variable indicates the TV. The default TV is the Device Variable 2 "Torque". To select the Tertiary Variable, see Section 8.2.3.

### 9.3.31 Device Variable 249: Quaternary Variable

This variable indicates the QV. The default QV is the Device Variable 3 "Temperature". To select the Quaternary Variable, see Section 8.2.3.

# Section 10: Tables

## 10.1 Array Codes

**Table 268. Array Codes on EleHRT-24**

Code	Description	Handling	User Level (*)
0	Name Plate – Serial Number	Read and Write	Service
1	Name Plate – Actuator Size	Read and Write	Service
2	Name Plate – WD	Read and Write	Service
3	Name Plate – Enclosure	Read and Write	Service
4	Name Plate – Certificate	Read and Write	Service
5	Name Plate – Lubricant	Read and Write	Service
6	Motor Data – Motor Code	Read and Write	Service
7	Valve Data – Tag Name	Read and Write	User
8	Valve Data – Serial Number	Read and Write	User
9	Valve Data – Valve Manufacturer	Read and Write	User
10	Valve Data – Break to Open Torque	Read and Write	User
11	Valve Data – Break Steam Thrust	Read and Write	User
12	Valve Data – Valve Coupling Type	Read and Write	User
13 to 255	Undefined	-	-

**NOTE:**

\* “User Level” indicates the user level permissions required to modify the parameter.

## 10.2 Param\_E Parameters Codes (Enumerated)

**Table 269. Param\_E Parameters Codes**

Code	Description	RW	User Level (*)	Minimum	Maximum	Notes
0	User	RW	Observer	0	3	0 = Observer 1 = User 2 = Service 3 = Manufacturer
1	Write Protection	RW	User	0	1	0 = Disabled 1 = Enabled
2	Backward Compatibility Mode	RW	Service	0	1	0 = Disabled 1 = Enabled
3	Reserved	RW	Service	0	1	Reserved
4	Reserved	RW	Service	0	1	Reserved
5	Local Display Language	RW	User	0	9	0 = English 1 = French 2 = Spanish 3 = Italian 4 = Portuguese 5 = Turkish 6 = Russian 7 = Norwegian 8 = Romanian 9 = German
6	Logic Board RS232 Baud Rate	RW	User	0	1	0 = 9600 bps 1 = 19200 bps
7	Wink Command	RW	User	0	1	0 = No Operation 1 = Wink Command
8	Force Local Selector	RW	Service	0	2	0 = No force selector 1 = Force Selector to OFF 2 = Force Selector to LOCAL
9	Bluetooth® Name Source	RW	User	0	1	0 = Actuator Serial Number 1 = Valve Tag
10	Bluetooth Enabled	RW	User	0	1	0 = Disabled 1 = Enabled
11	Interlock Signal Type Open	RW	User	0	2	0 = Absent 1 = Present 2 = Off
12	Interlock Signal Type Close	RW	User	0	2	0 = Absent 1 = Present 2 = Off
13	Reset Alarms and Warnings Active	RW	User	0	1	0 = No Operation 1 = Execute Command
14	Clear Alarms and Warnings Logs	RW	User	0	1	0 = No Operation 1 = Execute Command
15	Torque Mode	RW	User	0	1	0 = 3 Points 1 = Standard
16	9 V Lithium Battery	RW	User	0	1	0 = Absent 1 = Present

**NOTE:**

\* "User Level" indicates the user level permissions required to modify the parameter.

**Table 270. Param\_E Parameters Codes (Continued)**

Code	Description	RW	User Level (*)	Minimum	Maximum	Notes
17	AS1 Relay Function	RW	User	0	29	0 = Open limit 1 = Close limit 2 = Position >= % 3 = Position <= % 4 = Closing 5 = Opening 6 = Running 7 = Blinker 8 = Mid-Travel 9 = Local Selected 10 = Remote Selected 11 = Local STOP On 12 = ESD/PST-efs 13 = Man. Operation 14 = Motor Over Temp. 15 = Hi-Hi Torque 16 = Hi-Hi Torque in opening 17 = Hi-Hi Torque in closing 18 = Jammed in Open 19 = Jammed in Close 20 = Jammed Valve 21 = Low Battery 22 = Warnings
18	AS2 Relay Function	RW	User	0	29	0 = Open limit 1 = Close limit 2 = Position >= % 3 = Position <= % 4 = Closing 5 = Opening 6 = Running 7 = Blinker 8 = Mid-Travel 9 = Local Selected 10 = Remote Selected 11 = Local STOP On 12 = ESD/PST-efs 13 = Man. Operation 14 = Motor Over Temp. 15 = Hi-Hi Torque 16 = Hi-Hi Torque in opening 17 = Hi-Hi Torque in closing 18 = Jammed in Open 19 = Jammed in Close 20 = Jammed Valve 21 = Low Battery 22 = Warnings
19	AS3 Relay Function	RW	User	0	29	0 = Open limit 1 = Close limit 2 = Position >= % 3 = Position <= % 4 = Closing 5 = Opening 6 = Running 7 = Blinker 8 = Mid-Travel 9 = Local Selected 10 = Remote Selected 11 = Local STOP On 12 = ESD/PST-efs 13 = Man. Operation 14 = Motor Over Temp. 15 = Hi-Hi Torque 16 = Hi-Hi Torque in opening 17 = Hi-Hi Torque in closing 18 = Jammed in Open 19 = Jammed in Close 20 = Jammed Valve 21 = Low Battery 22 = Warnings

**NOTE:**

\* "User Level" indicates the user level permissions required to modify the parameter.

**Table 271. Param\_E Parameters Codes (Continued)**

Code	Description	RW	User Level (*)	Minimum	Maximum	Notes
20	AS4 Relay Function	RW	User	0	29	0 = Open limit 1 = Close limit 2 = Position >= % 3 = Position <= % 4 = Closing 5 = Opening 6 = Running 7 = Blinker 8 = Mid-Travel 9 = Local Selected 10 = Remote Selected 11 = Local STOP On 12 = ESD/PST-efs 13 = Man. Operation 14 = Motor Over Temp. 15 = Hi-Hi Torque 16 = Hi-Hi Torque in opening 17 = Hi-Hi Torque in closing 18 = Jammed in Open 19 = Jammed in Close 20 = Jammed Valve 21 = Low Battery 22 = Warnings
21	AS5 Relay Function	RW	User	0	29	0 = Open limit 1 = Close limit 2 = Position >= % 3 = Position <= % 4 = Closing 5 = Opening 6 = Running 7 = Blinker 8 = Mid-Travel 9 = Local Selected 10 = Remote Selected 11 = Local STOP On 12 = ESD/PST-efs 13 = Man. Operation 14 = Motor Over Temp. 15 = Hi-Hi Torque 16 = Hi-Hi Torque in opening 17 = Hi-Hi Torque in closing 18 = Jammed in Open 19 = Jammed in Close 20 = Jammed Valve 21 = Low Battery 22 = Warnings
22	AS6 Relay Function	RW	User	0	29	0 = Open limit 1 = Close limit 2 = Position >= % 3 = Position <= % 4 = Closing 5 = Opening 6 = Running 7 = Blinker 8 = Mid-Travel 9 = Local Selected 10 = Remote Selected 11 = Local STOP On 12 = ESD/PST-efs 13 = Man. Operation 14 = Motor Over Temp. 15 = Hi-Hi Torque 16 = Hi-Hi Torque in opening 17 = Hi-Hi Torque in closing 18 = Jammed in Open 19 = Jammed in Close 20 = Jammed Valve 21 = Low Battery 22 = Warnings

**NOTE:**

\* "User Level" indicates the user level permissions required to modify the parameter.

**Table 272. Param\_E Parameters Codes (Continued)**

Code	Description	RW	User Level (*)	Minimum	Maximum	Notes
23	AS7 Relay Function	RW	User	0	29	23 = Mid-Travel Alarm 24 = EFS in manual 25 = PST Failed 26 = MAINS (only AS8) 27 = EFS Mid-Travel 28 = INTERLOCK/PST 29 = EFS Coil Off 30 = Heater (Only for AS8)
24	AS8 Relay Function	RW	User	0	30	23 = Mid-Travel Alarm 24 = EFS in manual 25 = PST Failed 26 = MAINS (Only AS8) 27 = EFS Mid-Travel 28 = INTERLOCK/PST 29 = EFS Coil Off 30 = Heater (Only for AS8)
25	AS1 Relay Contact	RW	User	0	1	0 = Break 1 = Make
26	AS2 Relay Contact	RW	User	0	1	0 = Break 1 = Make
27	AS3 Relay Contact	RW	User	0	1	0 = Break 1 = Make
28	AS4 Relay Contact	RW	User	0	1	0 = Break 1 = Make
29	AS5 Relay Contact	RW	User	0	1	0 = Break 1 = Make
30	AS6 Relay Contact	RW	User	0	1	0 = Break 1 = Make
31	AS7 Relay Contact	RW	User	0	1	0 = Break 1 = Make
32	AS8 Relay Contact	RW	User	0	1	0 = Break 1 = Make
33	EFS Automatic reset	RW	User	0	1	0 = Off 1 = On
34	Spring Action	RW	User	0	1	0 = Close
35	Electrical Command	RW	User	0	1	0 = Disabled 1 = Enabled
36	EFS Input Mode	RW	User	0	1	0 = PST-efs 1 = EFS
37	EFS Signal Type	RW	User	0	1	0 = Absent 1 = Present
38	PST Mode	RW	User	0	3	0 = Off 1 = Auto 2 = Manual 3 = Manual + Auto
39	DIN1 Function	RW	User	0	29	See "AS1 Relay Function"
40	DIN2 Function	RW	User	0	29	See "AS1 Relay Function"
41	DIN3 Function	RW	User	0	29	See "AS1 Relay Function"
42	DIN4 Function	RW	User	0	29	See "AS1 Relay Function"
43	DIN5 Function	RW	User	0	29	See "AS1 Relay Function"
44	DIN6 Function	RW	User	0	29	See "AS1 Relay Function"
45	ESD Signal Type	RW	User	0	1	0 = Absent 1 = Present
46	Positioner Polarity	RW	User	0	1	0 = Standard (4 mA = Close) 1 = Reversed (4 mA = Open)
47	Output 4 to 20 mA Signal	RW	User	0	1	0 = Position 1 = Torque
48	Output 4 to 20 mA Polarity	RW	User	0	1	0 = 4 mA Close 1 = 4 mA Open
49	Close Direction	RW	User	0	1	0 = CW 1 = CCW
50	Close Limit by	RW	User	0	1	0 = Position 1 = Torque

**NOTE:**

\* "User Level" indicates the user level permissions required to modify the parameter.

**Table 273. Param\_E Parameters Codes (Continued)**

Code	Description	RW	User Level (*)	Minimum	Maximum	Notes
51	Open Limit by	RW	User	0	1	0 = Position 1 = Torque
52	Remote Controls	RW	User	0	6	0 = Off 1 = 4 wires latched 2 = 3 wires push to run 3 = 3 wires latched 4 = Reserved 5 = 2 wires open if signal off 6 = 2 wires open if signal on
53	Remote Stop	RW	User	0	1	0 = Break 1 = Make
54	Local Controls – Control Mode	RW	User	0	3	0 = Latched 1 = Push to run 2 = Latched instant reverse 3 = Push to run through AS6 to AS7
55	Actuator Speed Eng. Unit	RW	Service	0	3	0 = s/90° 1 = RPM 2 = mm/s 3 = ins/s
56	Torque/Thrust Eng. Unit	RW	Service	0	3	0 = lbf 1 = Nm 2 = lb 3 = kN
57	Motor Type	RW	Service	0	2	0 = AC 3 Phase 1 = AC 1 Phase 2 = DC
58	Motor Poles	RW	Service	0	15	0 = 2 poles 1 = 4 poles 2 = 6 poles 3 = 8 poles 4 = 10 poles 5 = 12 poles 6 = 14 poles 7 = 16 poles 8 = 18 poles 9 = 20 poles 10 = 22 poles 11 = 24 poles 12 = 26 poles 13 = 28 poles 14 = 30 poles 15 = 32 poles
59	Motor Service	RW	Service	0	6	0 = S2/15 min 1 = S4/25%/60 start/h 2 = S4/25%/200 start/h 3 = S4/25%/600 start/h 4 = S4/25%/1200 start/h 5 = S4/25%/3600 start/h 6 = S9
60	Torque Sensor I24 – Frequency	RW	Service	0	1	0 = 50 Hz 1 = 60 Hz
61	Hardware Configuration	RW	Service	0	12	0 = Base Card (No bus card) 1 = LonWorks® 2 = Modbus 3 = PROFIBUS 4 = Modbus M 5 = FF 6 = HART 7 = ProV1 8 = ProV1_R 9 = Modbus Dewa 10 = ProV2 11 = ProV2_r 12 = Mod-1CHR
62	Software Type	RW	Service	0	4	0 = ICON/XTE 1 = F01 2 = 6K 3 = EFS 4 = EPN

**NOTE:**

\* "User Level" indicates the user level permissions required to modify the parameter.

**Table 274. Param\_E Parameters Codes (Continued)**

Code	Description	RW	User Level (*)	Minimum	Maximum	Notes
63	Logic Card Manufacturer	RW	Service	0	1	0 = Biffi 1 = Bettis
64	4 to 20 mA Card	RW	Service	0	1	0 = Absent 1 = Present
65	Sleep Mode	RW	Service	0	1	0 = Disabled 1 = Enabled
66	Monitor Relay in Sleep Mode	RW	Service	0	1	0 = Not Energized 1 = Energized
67	CMD Filter	RW	Service	0	100	0 = 1 Confirmation (Low Filter) 1 = 2 Confirmations 2 = 3 Confirmations to 30 to 99 = 31 Confirmations (High Filter) 100 = No Confirmations (No Filter)
68	ESD/Interlock Dig. Input Filter	RW	Service	0	30	0 = 0.1 s (low filter) 1 = 0.2 s 2 = 0.3 s 3 = 0.4 s 4 = 0.5 s 5 = 0.6 s 6 = 0.7 s 7 = 0.8 s 8 = 0.9 s 9 = 1 s 10 = 1.1 s 11 = 1.2 s 12 = 1.3 s 13 = 1.4 s 14 = 1.5 s 15 = 1.6 s 16 = 1.7 s 17 = 1.8 s 18 = 1.9 s 19 = 2 s 20 = 2.1 s 21 = 2.2 s 22 = 2.3 s 23 = 2.4 s 24 = 2.5 s 25 = 2.6 s 26 = 2.7 s 27 = 2.8 s 28 = 2.9 s 29 = 3 s 30 = 3.1 s (high filter)
69	Interlock Mode	RW	Service	0	1	0 = Standard 1 = Advanced
70	Direction Test Timeout	RW	Service	0	25	0 = 100 ms 1 = 400 ms 2 to 25 = 1000 ms
71	Additional Variables	RW	Service	0	1	0 = Standard 1 = Extended
72	Back Light	RW	Service	0	1	0 = Auto 1 = Always On

**NOTE:**

\* "User Level" indicates the user level permissions required to modify the parameter.

**Table 275. Param\_E Parameters Codes (Continued)**

Code	Description	RW	User Level (*)	Minimum	Maximum	Notes
73	Position Request From	RW	Service	0	1	0 = 4 to 20 mA 1 = Bus
74	1P Man	RW	Service	0	1	0 = Disabled 1 = Enabled
75	Positioner	RW	Service	0	1	0 = Disabled 1 = Enabled
76	Bus AN-OUT	RW	Service	0	1	0 = Torque 1 = Torque + Potentiometer
77	Fail-Safe	RW	Service	0	1	0 = Disabled 1 = Enabled
78	Serial Command	RW	Service	0	1	0 = Disabled 1 = Enabled
79	Upload New Firmware	RW	Service	0	1	0 = Off 1 = On
80	Terminal Board	RW	Service	0	4	0 = I24 1 = 5 Relays 2 = 8/9 Relays 3 = 12 Relays 4 = I24 Gold PR
81	Selector Mode	RW	Service	0	1	0 = Local 1 = Local + Remote
82	Logger Mode (**)	RW	User	0	3	0 = Off 1 = Event 2 = Recorder 3 = T-Recorder
83	Memory Mode (**)	RW	User	0	1	0 = Continuous 1 = Stop when full
84	HART Topology	RW	User	0	1	0 = Point to Point 1 = Multidrop
85	Set Torque Profile	RW	User	0	1	0 = No Operation 1 = Execute Command
86	Clear Recent Data Log	RW	User	0	1	0 = No Operation 1 = Execute Command
87	Actuator Reset	RW	Service	0	1	0 = No Operation 1 = Perform Actuator Reset
88	Bus Monitor	RW	Service	0	1	0 = Disabled 1 = Enabled
89	Maintenance Operation Command	RW	Service	0	1	0 = Not active 1 = Active
90	4 mA Calibration Command (HART)	RW	User	0	1	0 = No Operation 1 = Set 4 mA

**NOTES:**

- \* "User Level" indicates the user level permissions required to modify the parameter.
- \*\* Memory Mode can be modified only if Logger Mode is set to Off.
- \*\* Logger Mode can be changed only if its current value is Off, so if Logger Mode value is different from Off, it can be modified only by setting it to Off and then to a different value.

**Table 276. Param\_E Parameters Codes (Continued)**

Code	Description	RW	User Level (*)	Minimum	Maximum	Notes
91	20 mA Calibration Command (HART)	RW	User	0	1	0 = No Operation 20 mA 1 = Set 20 mA
92	ESD Action	RW	User	0	4	0 = Off 1 = Close 2 = Open 3 = Stay-put 4 = Go to %
93	2 Speed Timer - Close Direction Status	RW	User	0	1	0 = Off 1 = On
94	2 Speed Timer - Open Direction Status	RW	User	0	1	0 = Off 1 = On
95	Fail-Safe Action	RW	User	0	4	0 = Off 1 = Close 2 = Open 3 = Stay-put 4 = Go to %
96	Power Supply Type	RW	User	0	2	0 = AC 3 Phase 1 = AC 1 Phase 2 = DC
97	Power Supply Frequency	RW	User	0	1	0 = 50 Hz 1 = 60 Hz

**NOTE:**

- \* "User Level" indicates the user level permissions required to modify the parameter.
- \*\* Memory Mode can be modified only if Logger Mode is set to Off.
- \*\* Logger Mode can be changed only if its current value is Off, so if Logger Mode value is different from Off, it can be modified only by setting it to Off and then to a different value.

## 10.3 Param\_BE Parameters Codes (Bit Enumerated)

**Table 277. Param\_BE Parameters Codes**

Code	Description	RW	User Level (*)	Notes
0	Monitor Relay Options	RW	User	b7 = 1 Low Battery b6 = 1 Jammed Valve b5 = 1 Overtorque b4 = 1 Motor Hi Temp b3 = 1 Manual Operation b2 = 1 ESD/EFS Active b1 = 1 Local Off Selected b0 = 1 Local Stop On
1	EFS Action in case of	RW	User	b1 = 1 Selector in Off b0 = 1 Power Failure
2	ESD Priority	RW	User	b6: 0 = ESD Priority < 2 Speed Timer; 1 = ESD Priority > 2 Speed Timer b5: 0 = ESD Priority < Motion Inhibit; 1 = ESD Priority > Motion Inhibit b4: 0 = ESD Priority < Selector in Off; 1 = ESD Priority > Selector in Off b3: 0 = ESD Priority < Selector in Local; 1 = ESD Priority > Selector in Local b2: 0 = ESD Priority < Local Stop pressed; 1 = ESD Priority > Local Stop pressed b1: 0 = ESD Priority < Hi Torque Alarm; 1 = ESD Priority > Hi Torque Alarm b0: 0 = ESD Priority < Thermostat; 1 = ESD Priority > Thermostat
3	Local Controls – LED's color	RW	User	b2 "Alarm Led": 0 = Red; 1 = Yellow b1 "Close Led": 0 = Red; 1 = Green b0 "Open Led": 0 = Red; 1 = Green

**NOTE:**

- \* "User Level" indicates the user level permissions required to modify the parameter.

## 10.4 Param\_F Parameters Codes (Float)

**Table 278. Param\_F Parameters Codes**

Code	Description	RW	User Level (*)	Unit Code	Minimum	Maximum
0	Adjust Open Limit	W	User	%	-5.0	5.0
1	Adjust Close Limit	W	User	%	-5.0	5.0
2	Logic Card Hardware Revision	R	-	-	0.0	9.9
3	Motor Rating	RW	Service	KW	0.1	999.9
4	Motor Current – In	RW	Service	A	0.1	99.9
5	Motor Current – Is	RW	Service	A	0.1	999.9
6	Motor Current – Icc	RW	Service	A	0.1	999.9
7	Reversal Delay	RW	Service	s	0.5	5.0
8	Speed by-pass	RW	Service	s	0.0	25.5
9	Dead Band	RW	User	%	0.1	25.5

**NOTE:**

\* "User Level" indicates the user level permissions required to modify the parameter.

## 10.5 Param\_D Parameters Codes (Date)

**Table 279. Param\_D Parameters Codes**

Code	Description	RW	User Level (*)	Minimum	Maximum
0	Current Date and Time	RW	User	01/01/2000 00:00	31/12/2135 23:59
1	Next PST Date	R	-	01/01/2000 00:00	31/12/2135 23:59
2	Test Date	RW	Service	01/01/2000 00:00	31/12/2135 23:59
3	Torque Opening Profile Date	R	-	01/01/2000 00:00	31/12/2135 23:59
4	Torque Reference Opening Profile Date	R	-	01/01/2000 00:00	31/12/2135 23:59
5	Torque Closing Profile Date	R	-	01/01/2000 00:00	31/12/2135 23:59
6	Torque Reference Closing Profile Date	R	-	01/01/2000 00:00	31/12/2135 23:59
7	Last Maintenance Date	RW	User	01/01/2000 00:00	31/12/2135 23:59
8	Next Maintenance Date	RW	User	01/01/2000 00:00	31/12/2135 23:59
9	Start Up Date	RW	User	01/01/2000 00:00	31/12/2135 23:59
10	Recent Log Date	R	-	01/01/2000 00:00	31/12/2135 23:59
11	Log Start Date and Time (**)	RW	User	01/01/2000 00:00	31/12/2135 23:59

**NOTES:**

\* "User Level" indicates the user level permissions required to modify the parameter.

\*\* It can be modified only if Logger Mode is set to Off.

If the date entered by the user is older the current date of the actuator, the value is automatically set to the current date of the actuator.

## 10.6 Param\_U32 Parameters Codes (Unsigned Int-32)

**Table 280. Param\_U32 Parameters Codes**

Code	Description	RW	User Level (*)	Minimum	Maximum
0	FST Open Curve Stored	R	-	-	0
1	FST Close Curve Stored	R	-	-	0
2	PST Curve Stored	R	-	-	0
3	Encoder Limit 0% Value	R	-	-	0
4	Encoder Limit 100% Value	R	-	-	0
5	Torque by-pass	RW	User	%	0
6	Jammed Valve	RW	User	s	0
7	AS1 Relay Position	RW	User	%	0
8	AS2 Relay Position	RW	User	%	0
9	AS3 Relay Position	RW	User	%	0
10	AS4 Relay Position	RW	User	%	0
11	AS5 Relay Position	RW	User	%	0
12	AS6 Relay Position	RW	User	%	0
13	AS7 Relay Position	RW	User	%	0
14	AS8 Relay Position	RW	User	%	0
15	Duty min of EFS Control	RW	User	%	10
16	EFS Reset Delay	RW	User	s	1
17	PST Period	RW	User	Days	1
18	PST Hour	RW	User	Hour	0
19	PST Travel	RW	User	%	5
20	PST Pause	RW	User	s	2
21	Max OV-TR	RW	User	%	1
22	DIN1 Position	RW	User	%	0
23	DIN2 Position	RW	User	%	0
24	DIN3 Position	RW	User	%	0
25	DIN4 Position	RW	User	%	0
26	DIN5 Position	RW	User	%	0
27	DIN6 Position	RW	User	%	0
28	Positioner Close Position	RW	User	%	0
29	Positioner Open Position	RW	User	%	25
30	Standard Opening Torque	RW	User	%	40
31	Standard Closing Torque	RW	User	%	40
32	Torque Setup 3p Opening – Break Out	RW	User	%	40
33	Torque Setup 3p Opening – Peak Run	RW	User	%	40
34	Torque Setup 3p Opening – Ending	RW	User	%	40
35	Torque Setup 3p Opening – Break Out Zone	RW	User	%	0
36	Torque Setup 3p Opening – Ending Zone	RW	User	%	0
37	Torque Setup 3p Closing – Break Out	RW	User	%	40
38	Torque Setup 3p Closing – Peak Run	RW	User	%	40
39	Torque Setup 3p Closing – Ending	RW	User	%	40
40	Torque Setup 3p Closing – Break Out Zone	RW	User	%	0

**NOTE:**

\* "User Level" indicates the user level permissions required to modify the parameter.

**Table 281. Param\_U32 Parameters Codes (Continued)**

Code	Description	RW	User Level (*)	Unit Code	Minimum	Maximum
41	Torque Setup 3p Closing – Ending Zone	RW	User	%	0	100
42	Torque Sensor F01 – Potentiometer Opening 50%	RW	Service	-	0	1023
43	Torque Sensor F01 – Potentiometer Opening 100%	RW	Service	-	0	1023
44	Torque Sensor F01 – Potentiometer Closing 50%	RW	Service	-	0	1023
45	Torque Sensor F01 – Potentiometer Closing 100%	RW	Service	-	0	1023
46	Torque Sensor F01 – Factory Torque Limit Opening	RW	Service	-	0	255
47	Torque Sensor F01 – Factory Torque Limit Closing	RW	Service	-	0	255
48	Motor Reduction Gear	RW	Service	-	1	1000
49	Torque Sensor I24 – Speed Opening 0% (+5%)	RW	Service	RPM	0	5000
50	Torque Sensor I24 – Speed Opening 40% (+5%)	RW	Service	RPM	0	5000
51	Torque Sensor I24 – Speed Opening 70% (+5%)	RW	Service	RPM	0	5000
52	Torque Sensor I24 – Speed Opening 100% (+5%)	RW	Service	RPM	0	5000
53	Torque Sensor I24 – Speed Opening 40% (-5%)	RW	Service	RPM	0	5000
54	Torque Sensor I24 – Speed Opening 70% (-5%)	RW	Service	RPM	0	5000
55	Torque Sensor I24 – Speed Opening 100% (-5%)	RW	Service	RPM	0	5000
56	Torque Sensor I24 – Speed Closing 0% (+5%)	RW	Service	RPM	0	5000
57	Torque Sensor I24 – Speed Closing 40% (+5%)	RW	Service	RPM	0	5000
58	Torque Sensor I24 – Speed Closing 70% (+5%)	RW	Service	RPM	0	5000
59	Torque Sensor I24 – Speed Closing 100% (+5%)	RW	Service	RPM	0	5000
60	Torque Sensor I24 – Speed Closing 40% (-5%)	RW	Service	RPM	0	5000
61	Torque Sensor I24 – Speed Closing 70% (-5%)	RW	Service	RPM	0	5000
62	Torque Sensor I24 – Speed Closing 100% (-5%)	RW	Service	RPM	0	5000
63	Torque Sensor I24 – Voltage	RW	Service	V	10	1000
64	Torque Sensor I24 – K Temp	RW	Service	%	0	20
65	Torque Sensor I24 – Factory Torque Limit Opening	RW	Service	-	0	255
66	Torque Sensor I24 – Factory Torque Limit Closing	RW	Service	-	0	255
67	Torque Opening Profile – Break Out	R	-	%	0	255
68	Torque Opening Profile – Peak Run	R	-	%	0	255
69	Torque Opening Profile – Ending	R	-	%	0	255
70	Torque Reference Opening Profile – Break Out	R	-	%	0	255
71	Torque Reference Opening Profile – Peak Run	R	-	%	0	255
72	Torque Reference Opening Profile – Ending	R	-	%	0	255
73	Torque Closing Profile – Break Out	R	-	%	0	255
74	Torque Closing Profile – Peak Run	R	-	%	0	255
75	Torque Closing Profile – Ending	R	-	%	0	255
76	Torque Reference Closing Profile – Break Out	R	-	%	0	255
77	Torque Reference Closing Profile – Peak Run	R	-	%	0	255
78	Torque Reference Closing Profile – Ending	R	-	%	0	255
79	General Log – Contactor Cycles	R	-	-	0	-
80	General Log – Motor Run Time	R	-	Hour	0	-
81	General Log – Time without power	R	-	Hour	0	-
82	General Log – Utilization Rate	R	-	%	0	65535
83	General Log – Number of Motor Thermostat Alarms	R	-	-	0	65535
84	General Log – Number of Torque Alarms	R	-	-	0	65535
85	Recent Log – Contactor Cycles	R	-	-	0	-

**NOTE:**

\* “User Level” indicates the user level permissions required to modify the parameter.

**Table 282. Param\_U32 Parameters Codes (Continued)**

Code	Description	RW	User Level (*)	Unit Code	Minimum	Maximum
86	General Log – Motor Run Time	R	-	Hour	0	-
87	General Log – Time without power	R	-	Hour	0	-
88	General Log – Utilization Rate	R	-	%	0	65535
89	General Log – Number of Motor Thermostat Alarms	R	-	-	0	65535
90	General Log – Number of Torque Alarms	R	-	-	0	65535
91	Torque Stop Zone	RW	Service	%	0	20
92	Current Sensor 2 A	RW	Service	-	0	1023
93	Current Sensor 3.5 A	RW	Service	-	0	1023
94	Current Sensor 7 A	RW	Service	-	0	1023
95	Current Sensor 15 A	RW	Service	-	0	1023
96	Current Sensor 30 A	RW	Service	-	0	1023
97	4 to 20 mA Input Configuration – 4 mA	RW	Service	-	0	1900
98	4 to 20 mA Input Configuration – 20 mA	RW	Service	-	2100	4095
99	4 to 20 mA Output Configuration – 4 mA	RW	Service	-	0	1900
100	4 to 20 mA Output Configuration – 20 mA	RW	Service	-	2100	4095
101	Speed Band	RW	Service	-	0	255
102	Voltage Span	RW	Service	V	10	1000
103	Voltage Span (bit)	R	-	-	0	4095
104	Sample Interval	RW	User	Seconds	1	3600
105	Byte Free 0	RW	User	-	0	255
106	Byte Free 1	RW	User	-	0	255
107	Byte Free 2	RW	User	-	0	255
108	Byte Free 3	RW	User	-	0	255
109	Byte Free 4	RW	Service	-	0	255
110	Byte Free 5	RW	Service	-	0	255
111	Byte Free 6	RW	Service	-	0	255
112	Byte Free 7	RW	Service	-	0	255
113	Bit Free 0	RW	User	-	0	1
114	Bit Free 1	RW	User	-	0	1
115	Bit Free 2	RW	User	-	0	1
116	Bit Free 3	RW	User	-	0	1
117	Bit Free 4	RW	Service	-	0	1
118	Bit Free 5	RW	Service	-	0	1
119	Bit Free 6	RW	Service	-	0	1
120	Bit Free 7	RW	Service	-	0	1
121	Word Free 0	RW	User	-	0	65535
122	Word Free 1	RW	User	-	0	65535
123	Word Free 2	RW	User	-	0	65535
124	Word Free 3	RW	User	-	0	65535
125	Word Free 4	RW	Service	-	0	65535
126	Word Free 5	RW	Service	-	0	65535
127	Word Free 6	RW	Service	-	0	65535
128	Word Free 7	RW	Service	-	0	65535
129	Set Close Reference Torque Curve	RW	User	-	0	100

**NOTE:**

\* "User Level" indicates the user level permissions required to modify the parameter.

**Table 283. Param\_U32 Parameters Codes (Continued)**

Code	Description	RW	User Level (*)	Unit Code	Minimum	Maximum
130	Set Open Reference Torque Curve	RW	User	-	0	100
131	Set PST Reference Curve	RW	User	-	0	16
132	Set EFS Reference Curve	RW	User	-	0	16
133	EFS Curves Stored	R	-	-	0	16
134	Max T-PST	RW	User	%	1	1000
135	Max T RET	RW	User	%	1	1000
136	Positioner Motion Inhibit	RW	User	Sec	1	255
137	General Log - Opening Time	R	Observer	Sec	0	65535
138	General Log - Closing Time	R	Observer	Sec	0	65535
139	ESD Position	RW	User	%	0	100
140	2 Speed Timer - Close Direction Start Position	RW	User	%	0	100
141	2 Speed Timer - Close Direction Stop Position	RW	User	%	0	100
142	2 Speed Timer - Close Direction ON Time	RW	User	Sec	2	200
143	2 Speed Timer - Close Direction OFF Time	RW	User	Sec	1	200
144	2 Speed Timer - Open Direction Start Position	RW	User	%	0	100
145	2 Speed Timer - Open Direction Stop Position	RW	User	%	0	100
146	2 Speed Timer - Open Direction ON Time	RW	User	Sec	2	200
147	2 Speed Timer - Open Direction OFF Time	RW	User	Sec	1	200
148	Fail-Safe Delay	RW	User	Sec	0	255
149	Fail Safe Position	RW	User	%	0	100
150	Power Supply Voltage	RW	Service	V	10	1000

**NOTE:**

\* "User Level" indicates the user level permissions required to modify the parameter.

## 10.5 Param\_S32 Parameters Codes (Signed Int-32)

**Table 284. Param\_S32 Parameters Codes**

Code	Description	RW	User Level (*)	Unit Code	Minimum	Maximum
0	General Log - Base Card Minimum Temperature	R	-	°C	-127	128
1	General Log - Base Card Maximum Temperature	R	-	°C	-127	128
2	General Log - Terminal Board Minimum Temperature	R	-	°C	-127	128
3	General Log - Terminal Board Maximum Temperature	R	-	°C	-127	128
4	General Log - Motor Maximum Temperature	R	-	°C	-127	128
5	Recent Log - Base Card Minimum Temperature	R	-	°C	-127	128
6	Recent Log - Base Card Maximum Temperature	R	-	°C	-127	128
7	Recent Log - Terminal Board Minimum Temperature	R	-	°C	-127	128
8	Recent Log - Terminal Board Maximum Temperature	R	-	°C	-127	128
9	Recent Log - Motor Maximum Temperature	R	-	°C	-127	128
10	Heater Base Reference	RW	Service	°C	-50	50
11	Heater Display Reference	RW	Service	°C	-50	50
12	Heater Terminal Board Reference	RW	Service	°C	-50	50

**NOTE:**

\* "User Level" indicates the user level permissions required to modify the parameter.

## 10.6 Param\_Str8 Parameters Codes (String8)

**Table 285. Param\_Str8 Parameters Codes**

Code	Description	RW	User Level (*)
0	Password (**)	RW	Observer
1	Actuator Speed Value	RW	Service
2	Torque/Thrust Value	RW	Service

**NOTES:**

\* "User Level" indicates the user level permissions required to modify the parameter.

\*\* Always read as 0x3030303030303030 ("00000000" in ASCII).

## 10.7 Param\_Str4 Parameters Codes (String4)

**Table 286. Param\_Str4 Parameters Codes**

Code	Description	RW	User Level (*)
0	Logic Card Firmware Revision K22	R	-
1	Logic Card Firmware Revision PIC	R	-
2	Encoder Hardware Revision	R	-
3	Encoder Firmware Revision	R	-
4	Local Display Password	RW	User

**NOTE:**

\* "User Level" indicates the user level permissions required to modify the parameter.

## 10.8 FST Torque Curve ID

**Table 287. FST Torque Curve ID**

Value	Description
0	Reference Torque Curve
1	Most recent FST (Not Reference) recorded by the actuator
2	2nd recent FST (Not Reference) recorded by the actuator
..	and so on
100	100th recent FST (Not Reference) recorded by the actuator

## 10.9 FST Torque Type

**Table 288. FST Torque Type**

Value	Description
0	FST Open Torque Curve
1	FST Close Torque Curve

## 10.10 PST Curve ID

**Table 289. PST Curve ID**

Value	Description
0	PST Reference Curve
1	Most recent PST (Not Reference) recorded by the actuator
2	2nd recent PST (Not Reference) recorded by the actuator
..	and so on
16	16th recent PST (Not Reference) recorded by the actuator

## 10.11 PST Result

**Table 290. PST Result**

Value	Description
0	Reserved – Not Used
1	Passed
2	Failed
3	Reset
4	Failed T-PST
5	Failed T-RET
6	Failed OV-TR

## 10.12 PST Direction/EFS Direction

**Table 291. PST Direction/EFS Direction**

Value	Description
0	Close (Start from 100%)
1	Open (Start from 0%)

## 10.13 PST Mode

**Table 292. PST Mode**

Value	Description
0	Off
1	Auto
2	Manual
3	Manual + Auto

## 10.14 PST Status

**Table 293. PST Status**

Bits	Description
b5 to b31	Not Used
b4	1 = PST Reset
b3	1 = PST Failed – OV-TR
b2	1 = PST Failed – T-RET
b1	1 = PST Failed – T-PST
b0	1 = PST Passed

## 10.15 PST Reset Conditions

**Table 294. PST Reset Conditions**

Code	Description
b18 to b31	Not Used
b17	1 = EFS Mid-Travel
b16	1 = Hardware 1 Alarm
b15	1 = K2 Contactor Alarm
b14	1 = K1 Contactor Alarm
b13	1 = Speed Sensor Alarm
b12	1 = Hi Torque Alarm
b11	1 = Jammed Valve Alarm
b10	1 = Hi Temperature
b9	1 = Lost Phase Alarm
b8	1 = Main Supply Alarm
b7	1 = Thermostat Alarm
b6	1 = Position Sensor
b5	1 = Configuration Alarm
b4	1 = Fail-Safe
b3	1 = ESD
b2	1 = Remote Stop
b1	1 = Local Stop
b0	1 = Selector in Off

## 10.16 EFS Curve ID

**Table 295. EFS Curve ID**

Value	Description
0	EFS Reference Curve
1	Most recent EFS (Not Reference) recorded by the actuator
2	2nd recent EFS (Not Reference) recorded by the actuator
..	and so on
16	16th recent EFS (Not Reference) recorded by the actuator

## 10.17 Memory Mode

**Table 296. Memory Mode**

Value	Description
0	Continuous
1	Stop when full

## 10.18 Event Number

**Table 297. Event Number**

Value	Description
1	Most recent event recorded by the actuator
2	2nd recent event recorded by the actuator
..	and so on
128	128th recent EFS (Not Reference) recorded by the actuator

## 10.19 Event Code

**Table 298. Event Code**

Code	Description
0	Off
1	Open
2	Close

## 10.20 Recorder Number

**Table 299. Recorder Number**

Value	Description
1	Most recent Recorder recorded by the actuator
2	2nd recent Recorder recorded by the actuator
..	and so on
256	256th recent Recorder recorded by the actuator

## 10.21 T-Recorder Number

**Table 300. T-Recorder Number**

Value	Description
1	Most recent T-Recorder recorded by the actuator
2	2nd recent T-Recorder recorded by the actuator
..	and so on
256	256th recent T-Recent recorded by the actuator

## 10.22 Card ID

**Table 301. Card ID**

Value	Description
0	Base Card Report
1	4 to 20 mA Card Report
2	Terminal Board Report
3	EFS Card Report
4	Bus Interface 1 Card Report

## 10.23 Event Source

**Table 302. Event Source**

Code	Description
0	None
1	Bus Command
2	Remote Command
3	Local Command
4	ESD
5	Position Calibration
6	Torque Calibration
7	Fail-Safe
8	Position Request from bus
9	Position Request from 4 to 20 mA Input
10	Serial/Bluetooth Command
11	Start Positioner Mode
12	Stop Positioner Mode
13	Movement without electrical command
14	K1 Contactor fail
15	K2 Contactor fail
16	Configuration On
17	PST
18	EFS Fail-Safe
19	Reserved
20	Reserved
21	Power Up
22	Selector Moved from REMOTE to LOCAL/OFF
23	Stop in Remote

## 10.24 Alarm Number

**Table 303. Alarm Number**

Value	Description
1	Most recent Alarm recorded by the actuator
2	2nd recent Alarm recorded by the actuator
..	and so on
64	64th recent Alarm recorded by the actuator

## 10.25 Warning Number

**Table 304. Warning Number**

Value	Description
1	Most recent Warning recorded by the actuator
2	2nd recent Warning recorded by the actuator
..	and so on
64	64th recent Warning recorded by the actuator

## 10.26 Alarm Code

**Table 305. Alarm Code**

Code	Description
0	None
1	Configuration
2	Thermostat
3	Over Temperature
4	Low Battery
5	Hi-Hi torque in close
6	Hi-Hi torque in open
7	Jammed Valve in close
8	Jammed Valve in open
9	Position Signal
10	Speed Sensor
11	Main Supply
12	Lost Phase
13	K1 Contactor
14	K2 Contactor
15	Mid-Travel in close
16	Mid-Travel in open
17	Hardware 1
18	Request Signal
19	Direction Test
20	Hardware 2
21	Hardware 3
22	Hardware 4
23	Hardware 5
24	Hardware 6
25	Hardware 7
26	Hardware 8
27	Hardware 9
28	Hardware 10
29	EFS Mid-Travel
30	Hardware 11
31	Hardware 12
32	Hardware 13

## 10.27 Warning Code

**Table 306. Warning Code**

Code	Description
0	None
1	Hi Torque in Opening
2	Hi Torque in Closing
3	Over Temperature
4	Main Supply
5	Max. Contactor Cycles
6	Maintenance Required
7	Motor Current
8	Wrong Stroke Limits
9	Bus
10	PST
11	PST Failed – T1 (T-PST)
12	PST Failed – T2 (T-RET)
13	PST Failed – Over Travel

## 10.28 Connection Number

**Table 307. Connection Number**

Value	Description
1	Most recent Connection recorded by the actuator
2	2nd recent Connection recorded by the actuator
..	and so on
8	8th recent Connection recorded by the actuator

## 10.29 Password Level

**Table 308. Password Level**

Value	Description
0	Observer
1	User
2	Service
3	Manufacturer

## 10.30 Connection Type

**Table 309. Connection Type**

Code	Description
0	Bluetooth
1	RS232

## 10.31 Actuator Commands

**Table 310. Actuator Commands**

Bits	Description
b15-b10	Not Used
b9	1 = Baseline PST Command
b8	1 = Fail Safe Command
b7	1 = Interlock Open Command
b6	1 = Interlock Close Command
b5	1 = PST Command
b4	1 = Enable Positioner
b3	1 = ESD Command
b2	1 = Stop Command
b1	1 = Open Command
b0	1 = Close Command

If LOOP CURRENT MODE is ENABLED: The actuator is controlled by the 4 to 20 mA signal applied to terminals HART+ and HART-. "Open Command", "Close Command", "Stop Command" are cleared and discarded

If LOOP CURRENT MODE is DISABLED: The actuator is controlled by "Actuator Commands" and "Position Request" (if "Enable Positioner" is active).

## 10.32 Actuator Status 1

**Table 311. Actuator Status 1**

Bits	Description
b7	1 = Warning
b6	1 = Alarm
b5	1 = Local Selector in REMOTE
b4	1 = Local Selector in OFF
b3	1 = Local Selector in LOCAL
b2	1 = Monitor Relay
b1	1 = Open Limit
b0	1 = Close Limit

## 10.33 Actuator Status 2

**Table 312. Actuator Status 2**

Bits	Description
b7	1 = Interlock Close
b6	1 = Interlock Open
b5	1 = Positioner Mode
b4	1 = PST in progress
b3	1 = ESD
b2	1 = Opening
b1	1 = Closing
b0	1 = Moving

## 10.34 Actuator Status 3

**Table 313. Actuator Status 3**

Bits	Description
b7	1 = Hardwired Bus-On
b6	1 = Hardwired Stop Command
b5	1 = Hardwired Close Command
b4	1 = Hardwired Open Command
b3	1 = Hardwired Remote Mode
b2	1 = Motor Operation Inhibited
b1	1 = ESD/PST Control
b0	1 = Fail-Safe Action

## 10.35 Actuator Status 4

**Table 314. Actuator Status 4**

Bits	Description
b7	Not Used
b6	Not Used
b5	Not Used
b4	Not Used
b3	1 = Maintenance Operation
b2	1 = STOP in Remote
b1	1 = Log Recording
b0	Not Used

## 10.36 Actuator Status 5

**Table 315. Actuator Status 5**

Bits	Description
b7	Reserved
b6	1 = Manual Operation (Handwheel)
b5	1 = Local Configuration
b4	1 = Bus Open Travel Available
b3	1 = Bus Close Travel Available
b2	1 = Actuator Position $\leq$ yy% (DIN1 Position)
b1	1 = Actuator Position $\geq$ xx% (DIN2 Position)
b0	1 = Motor Temperature Enabled

## 10.37 Actuator Status 6

**Table 316. Actuator Status 6**

Bits	Description
b7	Reserved
b6	Reserved
b5	Reserved
b4	Reserved
b3	Reserved
b2	Reserved
b1	1 = Interlock Command Active
b0	1 = Intermediate Position

## 10.38 Heater Status

**Table 317. Heater Status**

Bits	Description
b7	Reserved
b6	Reserved
b5	Reserved
b4	Reserved
b3	Not Used
b2	1 = Display-Logic Card Heater Active
b1	1 = Terminal Board Heater Active
b0	1 = AS8 Heater Active

## 10.39 Digital Inputs Status

**Table 318. Digital Inputs Status**

Bits	Description
b7	Not Used
b6	ESD
b5	Interlock Open
b4	Interlock Close
b3	Auto/Man
b2	Hardwired Stop Command
b1	Hardwired Close Command
b0	Hardwired Open Command

## 10.40 Output Contacts Status 1

**Table 319. Output Contacts Status 1**

Bits	Description
b7	AS8 Status
b6	AS7 Status
b5	AS6 Status
b4	AS5 Status
b3	AS4 Status
b2	AS3 Status
b1	AS2 Status
b0	AS1 Status

## 10.41 Output Contacts Status 2

**Table 320. Output Contacts Status 2**

Bits	Description
b7	Not Used
b6	Not Used
b5	Not Used
b4	Not Used
b3	Not Used
b2	Not Used
b1	Not Used
b0	Monitor Relay Status

## 10.42 DIN Status

**Table 321. DIN Status**

Bits	Description
b7	Not Used
b6	Not Used
b5	DIN6 Status
b4	DIN5 Status
b3	DIN4 Status
b2	DIN3 Status
b1	DIN2 Status
b0	DIN1 Status

## 10.43 K1 Contactor Status

Table 322. K1 Contactor Status

Value	Description
1	K1 Contactor Closed
0	K1 Contactor Open

## 10.44 K2 Contactor Status

Table 323. K2 Contactor Status

Value	Description
1	K2 Contactor Closed
0	K2 Contactor Open

## 10.45 Motor Thermostat Status

Table 324. Motor Thermostat Status

Value	Description
1	Motor Thermostat Closed
0	Motor Thermostat Open

## 10.46 HART Interface Status

Table 325. HART Interface Status

Bits	Description
b7	Not Used
b6	Not Used
b5	Not Used
b4	Not Used
b3	Not Used
b2	Bus Communication Status (1 = Active, 0 = Not Active)
b1	Burst Mode Status (1 = Active, 0 = Not Active)
b0	Input 4 to 20 mA Status (1 = Ok, 0 = lower than 2 mA)

## 10.47 Alarms 1

**Table 326. Alarm List**

Bits	Description
b7	Jammed Valve in opening
b6	Jammed Valve in closing
b5	Hi-Hi Torque in opening
b4	Hi-Hi Torque in closing
b3	Low Battery
b2	Hi-Hi Temperature
b1	Motor Thermostat
b0	Configuration Error

## 10.48 Alarms 2

**Table 327. Alarm List**

Bits	Description
b7	Mid Travel in open
b6	Mid Travel in close
b5	K2 Contactor
b4	K1 Contactor
b3	Lost Phase
b2	Main Voltage
b1	Speed Sensor
b0	Position Sensor

## 10.49 Alarms 3

**Table 328. Alarm List**

Bits	Description
b7	Hardware 6
b6	Hardware 5
b5	Hardware 4
b4	Hardware 3
b3	Hardware 2
b2	Direction
b1	Request Signal
b0	Hardware 1

## 10.50 Alarms 4

**Table 329. Alarm List**

Bits	Description
b7	Hardware 13
b6	Hardware 12
b5	Hardware 11
b4	EFS Mid Travel
b3	Hardware 10
b2	Hardware 9
b1	Hardware 8
b0	Hardware 7

## 10.51 Warnings 1

**Table 330. Warning List**

Bits	Description
b7	Wrong Stroke Limits
b6	Motor Current
b5	Maintenance Request
b4	Contactors Cycles
b3	Main Voltage
b2	Hi Temperature
b1	Hi Torque in closing
b0	Hi Torque in opening

## 10.52 Warnings 2

**Table 331. Warning List**

Bits	Description
b7	Not Used
b6	Reserved
b5	Reserved
b4	PST Error – Over Travel
b3	PST Error – Max T2 (T-RET)
b2	PST Error – Max T1 (T-PST)
b1	PST Error – PST Failed
b0	Bus Fail

## 10.53 Encoder Status 1

**Table 332. Encoder Status List**

Bits	Description
b7	Encoder Calibration Status (1 = Calibrated, 0 = Not Calibrated)
b6	Reserved
b5	Reserved
b4	Reserved
b3	Reserved
b2	Reserved
b1	Reserved
b0	Close Direction (0 = CW, 1 = CCW)

## 10.54 Encoder Status 2

**Table 333. Encoder Status List**

Bits	Description
b7	Reserved
b6	Reserved
b5	Reserved
b4	Reserved
b3	Reserved
b2	Reserved
b1	CW/CCW Configuration updated (0 = Updated, 1 = Not Updated)
b0	Encoder Communication Status (0 = Ok, 1 = Interrupted)

## 10.55 User Level Logged

**Table 334. User Level List**

Bits	Description
3	Manufacturer
2	Service
1	User
0	Observer

## 10.56 Last PST Status

**Table 335. Last PST Status**

Bits	Description
b7	Not Used
b6	Not Used
b5	Not Used
b4	Reset
b3	Failed – Over Travel
b2	Failed – T-RET (T2)
b1	Failed – T-PST (T1)
b0	Passed

## 10.57 Last PST Reset Conditions 1

**Table 336. Last PST Reset Conditions 1**

Bits	Description
b7	Thermostat Alarm
b6	Position Sensor Alarm
b5	Configuration Alarm
b4	Fail Safe
b3	ESD
b2	Remote STOP
b1	Local STOP
b0	Selector in OFF

## 10.58 Last PST Reset Conditions 2

**Table 337. Last PST Reset Conditions 2**

Bits	Description
b7	K2 Contactor Alarm
b6	K1 Contactor Alarm
b5	Speed Sensor Alarm
b4	Hi Torque Alarm
b3	Jammed Valve Alarm
b2	Hi Temperature Alarm
b1	Lost Phase Ala
b0	Main Supply Alarm

## 10.59 Last PST Reset Conditions 3

**Table 338. Last PST Reset Conditions 3**

Bits	Description
b7	Not Used
b6	Not Used
b5	Not Used
b4	Not Used
b3	Not Used
b2	Not Used
b1	EFS Mid Travel
b0	Hardware Alarm

# Section 11: Configuration via Local Interface

The EleHRT-24 allows connecting the ICON3000 v2 actuators family to a HART fieldbus. Described below are the facilities available by the **view and setup menu** of the actuator in which the EleHRT-24 is installed.

## 11.1 BUS Control

- DIN 1 to DIN 6: By this routine, it is possible to choose the condition associated to command 128, Device Variable 1 (actuator status) bits 7 to 12. Here below is the list of the available conditions:

**Table 339. BUS Control**

STATUS/ALARM		
• Open limit	• Remote selected	• Valve jammed in OP
• Closed limit	• Local stop active	• Valve jammed in CL
• Position <= xx %	• ESD signal on	• Low battery (if present)
• Position >= yy %	• Manual operation	• Mid-travel alarm in CL/OP
• Closing	• Motor over-temperature	• EFS in manual
• Opening	• Over-torque	• PST failed
• Motor running	• Over-torque in OP	• MAINS only AS8
• Blinker	• Over-torque in CL	• EFS mid-travel
• Mid-travel position	• Valve jammed	
• Local selected	• Warnings	

The following settings are supplied as standard:

- DIN1: mid-travel position
- DIN2: local stop active
- DIN3: motor over-temperature (motor thermostat alarm)
- DIN4: over-torque (Hi-Hi torque alarm)
- DIN5: valve jammed alarm
- DIN6: mid-travel alarm in OP/CL

- **Address:** Use this function to enter the polling address node. Each device must have its address. Each address must be associated to one only device. The available address range is from 0 to 63. Set 0 in point to point mode. Set address from 0 to 15 in multidrop mode.
- **Mode:** The available options are loop enable, loop disable and multidrop. Mode (loop enable and loop disable only) can be set also by the Universal Command 6.

**EleHRT-24:** Select loop enable if the actuator is controlled by the analog 4 to 20 mA (PV). Select loop disable or multidrop if the actuator is controlled by the digital HART signal, see Device Variable 3.

- **Device Number ID:** Use this function to set the HART device number ID. The number is normally set in factory and should not be changed. The Device Number ID must be unique for each field device.
- **HART Relay:** The available options are open and close . Use close in point to point and split range mode.

In multidrop mode:

- Use open if the actuator is not the last actuator of the 4 to 20 mA current loop.
- Use open if the actuator is the last actuator of the 4 to 20 mA current loop and it is closed by an external 250  $\Omega$  resistance placed between the signals HART+ and HART-.
- Use close if the actuator is the last actuator of the 4 to 20 mA current loop and the external 250  $\Omega$  resistance is not placed between the signals HART+ and HART- .

#### Configuration procedure:

- Move the local selector to OFF and then press simultaneously OPEN and STOP. Select the language and then enter the password according to the instructions "entering the set-up mode". When the message of display is "SET-UP MODE OK?" press YES. Press YES to select actuator set-up menu, press NO to scroll the list of available routines and then press YES to select the routine BUS.
- Press NO if the conditions DIN1 is correct. Press YES to change. Press NO to change condition to switch, press YES to select.
- Repeat the previous procedure for DIN 2 up to DIN 6.
- Press YES if the configured value of the polling node address (ADDRESS) is correct (from 1 to 63), or press NO to change, then press YES.
- Press YES if the configured value of the MODE (Loop current enable, loop current disable, multidrop) is correct, or press NO to change, then press YES.
- Press YES to confirm the configured Device number.

#### View procedure:

- Move the local selector to OFF and then press simultaneously OPEN and STOP. Select the language and then enter the password according to the instructions "entering the view mode". When the message of display is "VIEW MODE OK?" press YES. Press YES to select actuator set-up menu, press NO to scroll the list of available routines and then press YES to select BUS.
- Press YES to scroll the list of BUS parameters.

## 11.2 Positioner Function

The function is available only on the modulating actuators. The value 0.0 of position request, received from bus, corresponds to close request and the value 100.0 corresponds to open request. The ICON3000 compares the present position % of the actuator with the position request % received from the bus (analog 4 to 20 mA HART current loop or digital HART signal), and if the difference is greater than the dead band, the actuator is driven to reach the new requested position.

The following options can be configured via either bus or local operator interface:

- **Dead band:** Configurable from 0.1% to 25.5% of the maximum position error (difference among position request % and present position %). The configured value should be great enough to avoid "hunting" effect of the actuator.
- **Motion inhibit time:** It allows adjusting the length of the delay time between two cycles of the motor. It can be configured from 1 to 255 s and allows to set the maximum number of start/hour of electrical motor.

### Configuration procedure:

- Move the local selector to OFF and then press simultaneously OPEN and STOP. Select the language and then enter the password according to the instructions "entering the set-up mode". When the message of display is "SET-UP MODE OK?" press YES. Press YES to select actuator set-up menu, press NO to scroll the list of available routines and then press YES to select POSITIONER.
- Press YES if the configured value of the Dead Band is correct (from 0.1 to 25.5% of position error), or press NO to change, then press YES.
- Press YES if the configured value of the Motion Inhibit Time is correct (from 1 to 255 s), or press NO to change, then press YES.

### View procedure:

- Move the local selector to OFF and then press simultaneously OPEN and STOP. Select the language and then enter the password according to the instructions "entering the view mode". When the message of display is "VIEW MODE OK?" press YES. Press YES to select actuator set-up menu, press NO to scroll the list of available routines and then press YES to select the routine (POSITIONER).
- Press YES to scroll the list of parameters.

## 11.3 Fail-Safe Function

This function is available only if enabled in the restricted menu of actuator. It allows configuring the action of the actuator in case of loss of the 4 to 20 mA signal HART current loop. The action takes place only if the local selector is in REMOTE. When the 4 to 20 mA HART current loop restores, also the actuator restores at its normal functioning. The fail-safe function can be configured via either bus or local operator interface.

The hardwired controls ESD and INTERLOCKS override the Fail-Safe action according to the following diagram.

**Figure 10. Fail-Safe Function**

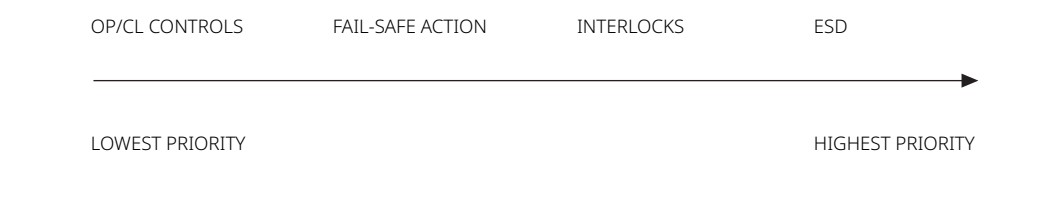

The following options can be configured:

- Fail-safe action: open, close, stay-put, go to position %, no action (OFF)
- Delay time before than the fail-safe action takes place (delay = 10 s + configured value)

### Configuration procedure:

- Move the local selector to OFF and then press simultaneously OPEN and STOP. Select the language and then enter the password according to the instructions "entering the set-up mode". When the message of display is "SET-UP MODE OK?" press YES. Press YES to select actuator set-up menu, press NO to scroll the list of available routines and then press YES to select FAIL-SAFE.
- Press YES if the configured ACTION is correct (open, close, stay-put, go to position xx%, off), or press NO to change, then press YES.
- Press YES if the configured value of the DELAY is correct (from 0 to 255 s), or press NO to change, then press YES.

### View procedure:

- Move the local selector to OFF and then press simultaneously OPEN and STOP. Select the language and then enter the password according to the instructions "entering the view mode". When the message of display is "VIEW MODE OK?" press YES. Press YES to select actuator set-up menu, press NO to scroll the list of available routines and then press YES to select the routine (FAIL-SAFE).
- Press YES to scroll the list of parameters.

## 11.4 Viewing Transmission Info

The following procedure allows seeing the most significant info relevant to the bus data transmission:

Move the local selector to OFF or REMOTE and then press YES until the display shows NODE REPORT. Press NO to exit or press YES to scroll the lost of transmission info.

**64 Bytes:** Information about the EleHRT-24 Interface (Card Report)

**Configuration change:** Configuration Change counter

**STX:** Number of valid messages received from the host (maximum before counter reset 65535)

**ACK:** Number of valid messages transmitted to the host (maximum before counter reset 65535)

**BACK:** Number of Burst messages transmitted (maximum before counter reset 65535)

**MB REC-COUNTER:** Current number of communication error with the Logic Card

**MB GEN-COUNTER:** Number of communication error with the Logic Card since last power up

## 11.5 Actuator Terminal Board

Figure 11. Actuator Terminal Board



**Figure 12. Terminal Board Connections for ICON3000 v2**

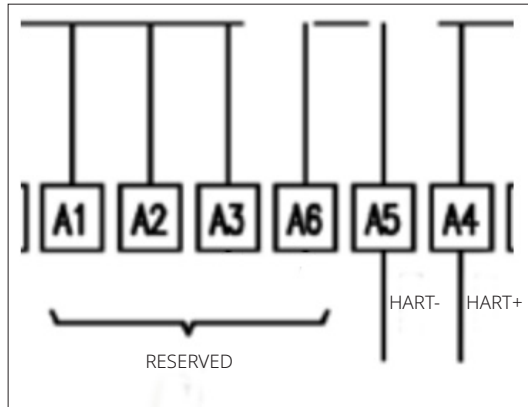

**Table 340. Legend**

Terminal Board	Signal	J4	J6
A1	Not Used	N/A	N/A
A2	Not Used	N/A	N/A
A3	Not Used	N/A	N/A
A4	HART+	1	+
A5	HART-	2	-
A6	Not Used	N/A	N/A



## Section 12: Certificate of Registration

EleHRT-24 Rev. 1 is a HART Registered device compliant with HART protocol revision 7.9. This version of the device is also FDI Registered. DD Files and other information are available on FieldComm Group official website: <https://www.fieldcommgroup.org>.

# Appendix A: HART Command 3 Communication Example

**Figure A- 1. Block Diagram**

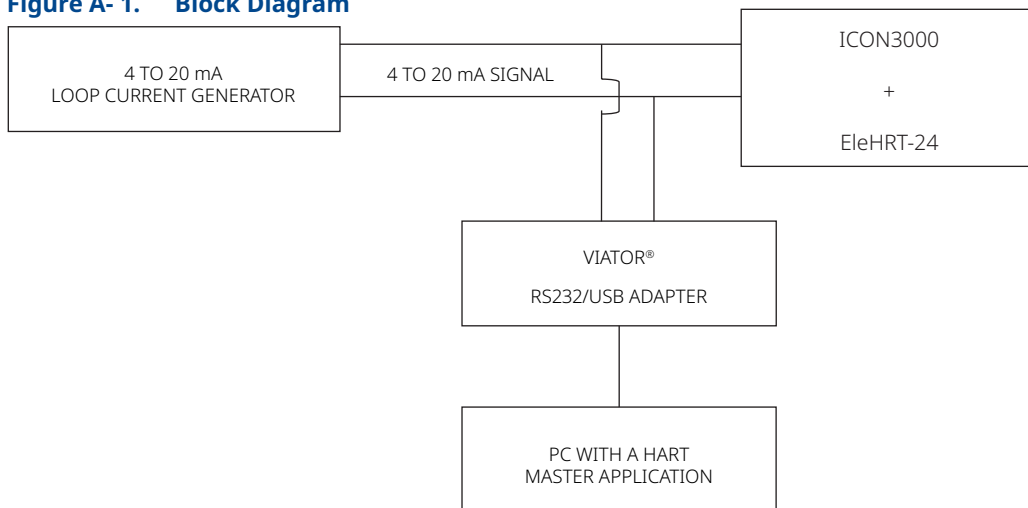

See Section 11.5 for Terminal Board Connections.

**Figure A- 2. Example of HART Command 3 Communication with Dynamic Variables Values (Decimal)**

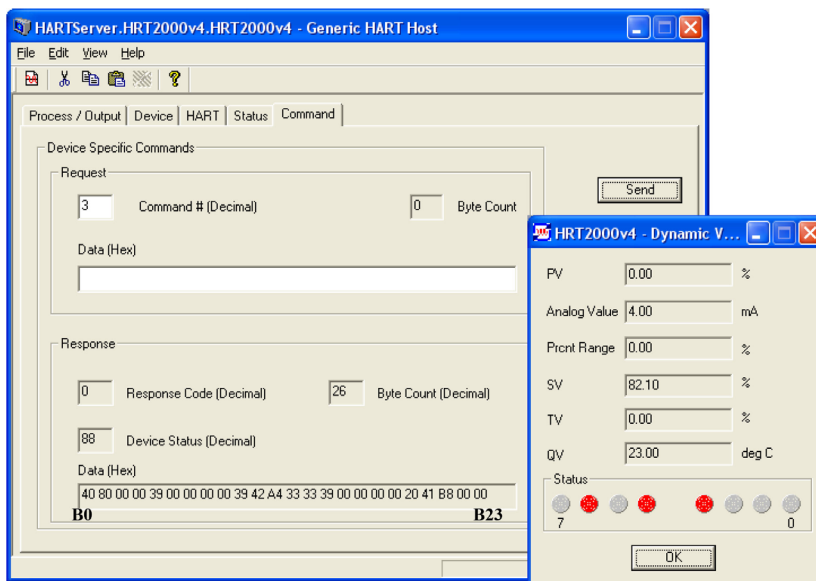

The window on the right shows the decimal value of Dynamic Variables and the Field Device Status; this window can be selected from "View > Dynamic Variables".

The command sent by the master is Universal Command 3 – Read Dynamic Variables.  
The response from the slave is a frame with the following values:

**Table A-1. Command 3 Response Values**

Data Bytes	Description	Values (Hex)	Values (Decimal)*
0 to 3	Loop Current (mA)	40 80 00 00	4.00
4	PV Units Code	39	57 = Percent
5 to 8	PV Value	00 00 00 00	0.0
9	SV Units Code	39	57 = Percent
10 to 13	SV Value	42 A4 33 33	82.1
14	TV Units Code	39	57 = Percent
15 to 18	TV Value	00 00 00 00	0.0
19	QV Units Code	20	32 = Degrees Celsius
20 to 23	QV Value	41 B8 00 00	23.0

**NOTE:**

\* Converted using IEEE-754 (IEC 559)

# Appendix B: Writing Variables and Parameters Data

To modify the writable variables and parameters, it is necessary to correctly set the user and the password in the corresponding User (Param\_E 0) and password (Param\_Str8 0).

4 User levels are available:

- **OBSERVER (lower level):** able to read only all the data
- **USER:** able to read all the data and to modify the variables and the parameter that require OBSERVER or USER permissions
- **SERVICE:** able to read all the data and to modify most the variables and the parameters that require OBSERVER, USER or SERVICE permissions
- **MANUFACTURER (higher level):** able to read all the data and to modify all the variables and the parameters.

The "User Level Logged" (Command 171 "Read Actuator Status") on the actuator indicates the permissions currently granted: its value is the result of the combination of the "User" (Param\_E 0) and the "Password" (Param\_Str8 0). At the power up, the EleHRT-24 login automatically as "USER" user level.

At the power up, the EleHRT-24 login automatically as "USER" user level.

If the Master tries to modify a variable/parameter without having the minimum required permissions, the value is discarded.

The HART Specific parameters listed below have no restrictions and they can be changed by any users:

- Polling Address (Universal Command 6)
- Loop Current Mode (Universal Command 6)
- Message (Universal Command 17)
- Tag (Universal Command 18)
- Descriptor (Universal Command 18)
- Date (Universal Command 18)
- Final Assembly Number (Universal Command 19)
- Long Tag (Universal Command 22)
- Dynamic Variables Assignments (Common Practice Command 51)
- Number of Response Preambles (Common Practice Command 59)
- Burst Mode Configuration (Common Practice Commands 103, 104, 105, 107, 108, 109)

### How to login as OBSERVER

Set "User" parameter (Param\_E 0) to 0x0000.

Set "Password" parameter (Param\_Str8 0) to any value.

### How to login as USER

Set "User" parameter (Param\_E 0) to 0x0000.

Please, contact the manufacturer for "Password" values.

### How to login as SERVICE or MANUFACTURER

These user levels are reserved for Service Technicians and manufacturer.

## Appendix C: Configuration Requirements for PST Command

This addendum describes the configuration settings required to perform the PST command. PST command is performed by the actuator only if:

- EFS Input Mode (Param\_E 36) = 0 → PST-EFS
- Interlock Mode (Param\_E 69) = 1 → Advanced

If at least one of the above parameters is configured differently, the PST command is ignored and not executed.

See actuator Installation, Operation and Maintenance Manual for additional details about the PST command.

Biffi Italia s.r.l.  
Strada Biffi 165  
29017 Fiorenzuola d'Arda (PC)  
Italy  
T +39 0523 944 411

For complete list of sales and manufacturing sites, please visit  
[www.biffi.it](http://www.biffi.it) or contact us at [biffi\\_italia@biffi.it](mailto:biffi_italia@biffi.it)

FCIM-20210-EN © 2025 Biffi. All rights reserved.

The contents of this publication are presented for informational purposes only, and while every effort has been made to ensure their accuracy, they are not to be construed as warranties or guarantees, express or implied, regarding the products or services described herein or their use or applicability. All sales are governed by our terms and conditions, which are available upon request. We reserve the right to modify or improve the designs or specifications of such products at any time without notice.

